



Europäisches Patentamt
European Patent Office
Office européen des brevets



Publication number: **0 579 097 A1**

EUROPEAN PATENT APPLICATION

Application number: **93110845.0**

Int. Cl.⁵: **A47C 3/02, A47C 3/18, A47C 9/00**

Date of filing: **07.07.93**

Priority: **15.07.92 IT MI921719**

Date of publication of application:
19.01.94 Bulletin 94/03

Designated Contracting States:
DE DK ES FR GB GR

Applicant: **LINEAGER S.R.L.**
Via G.di Vittorio 5
I-20030 Bovisio Masciago (Milan)(IT)

Inventor: **Achille, Baruffaldi**
Via F. Baracca 4
I-20030 Lentate sul Seveso, Milan(IT)

Representative: **Giambrocono, Alfonso, Dr.**
Ing. et al
Ing. A. Giambrocono & C. S.r.l.
Via Rosolino Pilo 19/B
I-20129 Milano (IT)

Ball joint device with damping blocks, for connecting the seat to the support column of a chair.

A ball joint device provided with damping blocks, for connecting the seat to the support column of a chair, comprising a ball head (2) to be fixed to said support column and housed in a housing (3) provided on the plate (4) which supports the chair seat, characterised in that said ball head (2) is connected

to a flange (7) provided with apertures (8) facing corresponding apertures provided in the plate (4), connection bolts (10) being provided passing through said apertures (8) and acting on said flange (8) and/or on said plate (4) via an elastic means (14).

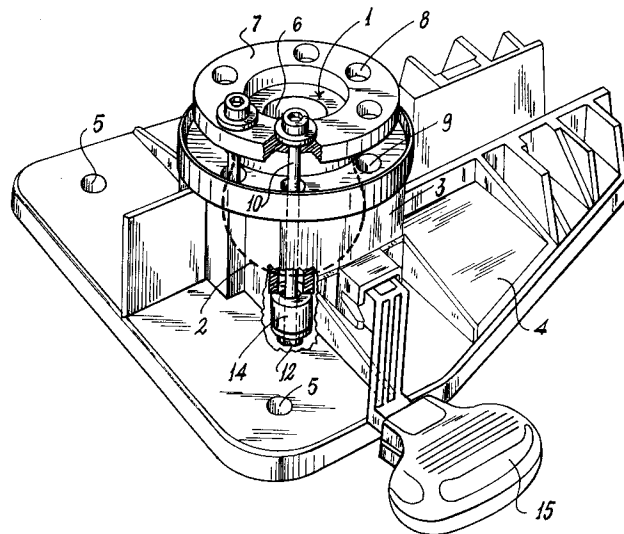

Fig. 1

EP 0 579 097 A1

This invention relates to a ball joint device provided with damping blocks, for connecting the seat to the support column of a chair, particularly but not necessarily a chair of office type.

As is well known, in such chairs a height-adjustable central column extends from a base usually comprising five or a different number of radially projecting arms, to its upper end there being connected a plate which supports the seat of the chair.

In this type of chair the connection between the column and the seat is normally such as to enable the seat to undergo some movement relative to the column in order to correct the inclination of the chair to the vertical, in addition to allowing its rotation and height adjustment.

Chairs have recently been constructed in which the seat-support plate can undergo limited rocking movements in every direction relative to the support column against elastic reactions which limit such rocking movements.

In a construction of this type, a ball head connected to the support column is snap-housed in a suitable recess provided in the plate which supports the seat.

Between said ball head and said support plate there is a ring of yieldable material which surrounds the entire ball head, such that when a person seated on the chair tends to rock the seat in any direction, the ring is compressed to allow the seat to undergo limited rocking relative to the support column by virtue of the elastic yieldability of said ring.

However, because of the high forces in play deriving from both the weight of the seated person and the lever arms concerned, such a construction results in considerable forces exerted on the elastic ring, so that it becomes compressed to an exaggerated extent, resulting in a certain feeling of instability to the person seated, this representing a considerable drawback to the acceptance of this type of chair. The object of the present invention is to provide a connection of the aforesaid type, in which the damping components operate in a different manner and are able to provide a greater elastic reaction although using analogous materials, this elastic reaction also being adjustable.

This object is attained by the device of the present invention comprising a ball head to be fixed to the support column, said ball head being housed in a housing provided on a plate supporting the chair seat, characterised in that said ball head is connected to a flange provided with apertures facing corresponding apertures provided in the plate, connection bolts being provided passing through said apertures and acting on said flange and/or on said plate via an elastic means.

The invention will be more apparent from the detailed description given hereinafter by way of non-limiting example with reference to the accompanying drawings, in which:

5 Figure 1 is a perspective view of a connection device according to the present invention seen from below; Figure 2 is a perspective schematic view of the connection device seen from above.

10 In said figures the reference numeral 1 indicates overall an element provided with a ball head 2, shown schematically by dashed lines, which is received in a housing 3 provided on a plate 4 which supports the seat and is fixed to it for example by screws passing through apertures 5.

15 The element 1 is connected to the chair support column, the end of which can for example enter the aperture 6 with which the element 1 is provided.

20 The plate 4 can be of any type, but according to the invention is preferably formed of moulded plastics material, and consequently on one side comprises stiffening ribs and on the opposite side, as shown in Figure 2, comprises a honeycomb structure which gives it considerable strength together with the required lightness.

25 The ball head element 1, also preferably of moulded plastics material, comprises a flange 7 which lies in a plane perpendicular to the plane of the support column and faces the end of the housing 3 which receives the ball head 2.

30 In the known art the gorge existing between the flange 7 and the end of the housing 3 carries a toroidal ring of yieldable material to enable it to react to any rocking of the plate 4 joined to the seat, while the element 1 remains rigidly connected to the support column and by virtue of the ball joint allows a limited rocking of the seat relative to the column.

35 As has already been stated, because of the considerable forces in play this connection system results in the described drawbacks, hence according to the present invention the flange 7 is provided with a series of apertures 8 distributed, more or less uniformly as required, along the entire circumference of the flange, and apertures 9 are provided within the body of the housing 3 through the entire height of the housing 3 to open in that face of the plate 4 visible in Figure 2.

40 As can be seen from Figure 2, appropriate spaces, the purpose of which will be apparent hereinafter, are provided in the honeycomb structure at these apertures.

45 Bolts 10 are passed through the facing apertures 8 and 9 so that their head 11 acts against the flange 7 and their nut 12 acts, via a suitable washer 13 and elastic bush 14, against that face of the plate 4 visible in Figure 2.

Only two bolts 10 are shown in the figures for clarity, it being however clear that the number of bolts 10 provided is equal to the number of apertures 8 and 9.

As will be apparent, when the plate 4 rocks relative to the element 1, some of the bolts 10 are put under tension whereas others are compressed. The tensioned bolts react by compressing their bush 14, which as stated is of elastically yieldable material and undergoes compression to hence provide good resistance which limits the rocking movements of the seat.

The amplitude of these rocking movements for equal force depends on the elastic coefficient of the material used for the bushes 14, this consequently being chosen in relation to the values concerned. However if the material proves excessively yieldable, according to a modification of the invention a further bush, not shown, can be provided again mounted about the bolts 10 but acting between the flange 7 and the upper edge of the housing 3, so that when the plate 4 rocks, one half of the elastic bushes 14 positioned on one side of the plate 4 and the other half of the bushes positioned on the opposite side of the plate 4 operate, all under compression.

Moreover according to the invention, the nut 12 can be tightened to a greater or lesser extent to preload the elastic bushes 14, so as to vary the force with which they operate. It is also possible to preload the various elastic bushes 14 to different extents so as to favour the rocking of the seat in a single direction, for example backwards and forwards rather than sideways.

It is likewise apparent that the control levers of a usual gas spring contained within the support column and controlled by a usual side lever 15 can be passed between one and another bolt 10.

A preferred embodiment of the invention has been illustrated and described, however its scope includes all possible modifications.

Claims

1. A ball joint device provided with damping blocks, for connecting the seat to the support column of a chair, comprising a ball head to be fixed to said support column and housed in a housing provided on the plate which supports the chair seat, characterised in that said ball head is connected to a flange provided with apertures facing corresponding apertures provided in the plate, connection bolts being provided passing through said apertures and acting on said flange and/or on said plate via an elastic means.

2. A device as claimed in claim 1, characterised in that said elastic means consist of bushes mounted about said bolts.

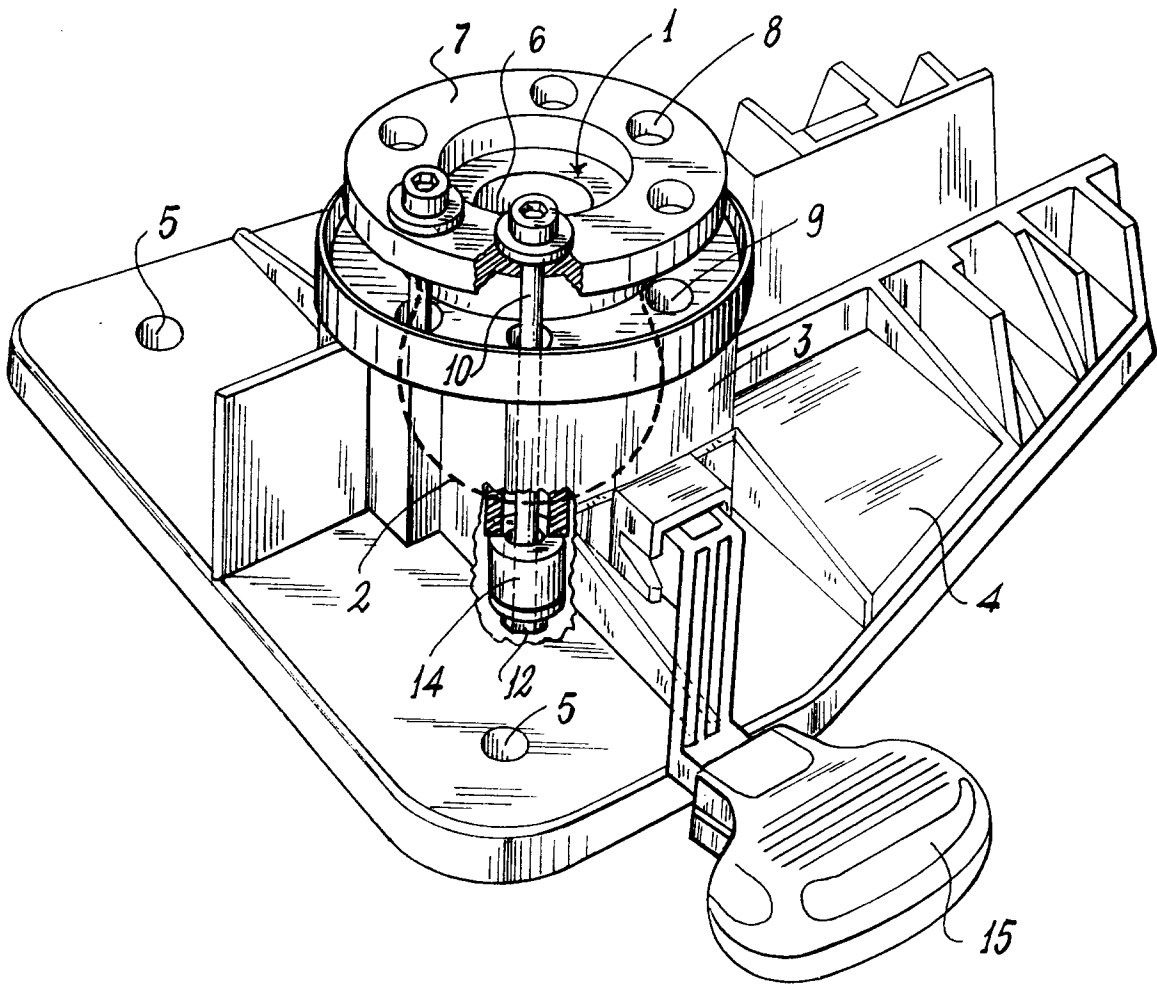

Fig. 1

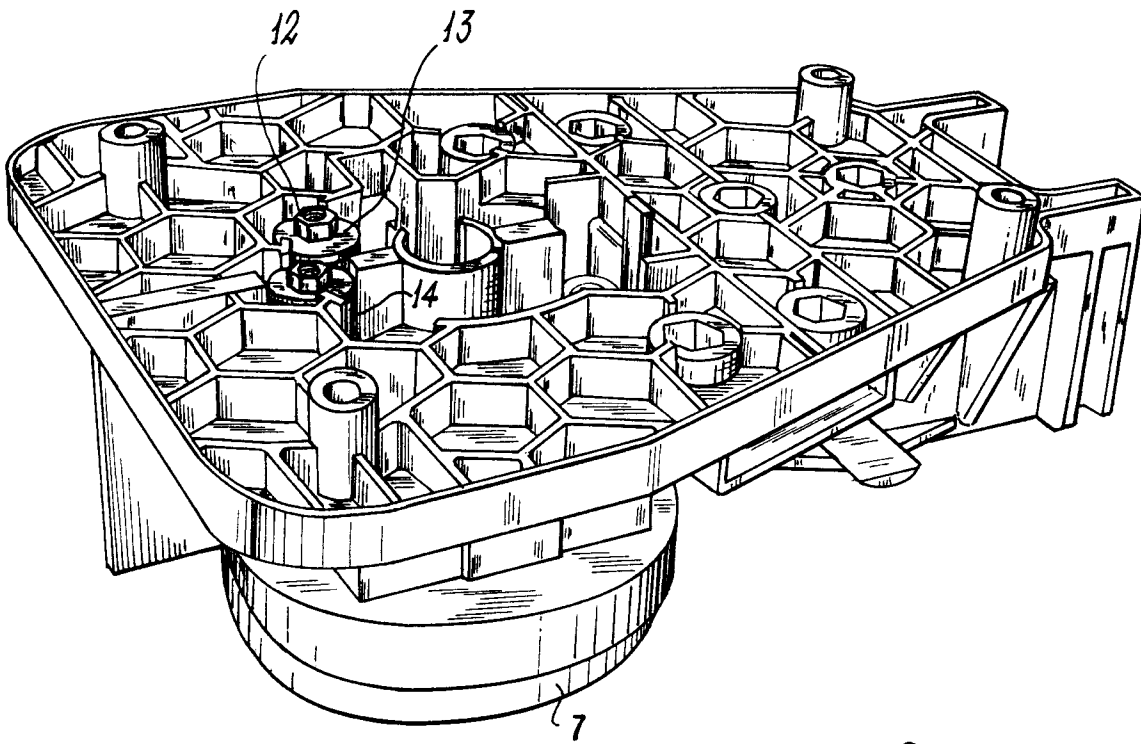

Fig. 2



DOCUMENTS CONSIDERED TO BE RELEVANT			
Category	Citation of document with indication, where appropriate, of relevant passages	Relevant to claim	CLASSIFICATION OF THE APPLICATION (Int. Cl.5)
A	WO-A-9 014 031 (COHEN) * page 1, line 1 - page 2, line 26; claims 1,2,6; figure 7 * * page 8, line 1 - line 35 * ----	1,2	A47C3/02 A47C3/18 A47C9/00
A	US-A-3 309 137 (WIEBE) * claims 1,2; figures 1-4 * ----	1,2	
A	US-A-2 132 291 (FITOS) * the whole document * -----	1,2	
			TECHNICAL FIELDS SEARCHED (Int. Cl.5)
			A47C A63G
The present search report has been drawn up for all claims			
Place of search THE HAGUE		Date of completion of the search 13 OCTOBER 1993	Examiner MYSLIWETZ W.P.
CATEGORY OF CITED DOCUMENTS X : particularly relevant if taken alone Y : particularly relevant if combined with another document of the same category A : technological background O : non-written disclosure P : intermediate document T : theory or principle underlying the invention E : earlier patent document, but published on, or after the filing date D : document cited in the application L : document cited for other reasons & : member of the same patent family, corresponding document			