



EUROPEAN PATENT APPLICATION

Application number : **93310423.4**

Int. Cl.⁵ : **E05F 5/06, B62D 25/12**

Date of filing : **22.12.93**

Priority : **22.12.92 GB 9226681**

Inventor : **Davis, Phillip**
7 South Street
East Rainton, Tyne & Wear (GB)

Date of publication of application :
29.06.94 Bulletin 94/26

Representative : **Godwin, Edgar James**
MARKS & CLERK,
57-60 Lincoln's Inn Fields
London WC2A 3LS (GB)

Designated Contracting States :
DE FR GB

Applicant : **NISSAN EUROPEAN**
TECHNOLOGY CENTRE LIMITED
Washington Road
Sunderland, Tyne & Wear SR5 3ND (GB)

Bump stop for interposal between relatively movable body parts.

A holder (12), with a head (13) for attachment to the trunk lid or tailgate of a vehicle, carries a hollow elongate rubber member (11) which has integral rings (31) separated by peripheral grooves (18). As the lid or tailgate closes, the relatively weak zones (32) defined by the grooves (18) are easily compressed. At the point where the lid or tailgate is latched, the rings (31) are in face-to-face contact, so that the stress/strain curve of the member (11) is steeper. A support (27), carried by the holder (12), resists the tendency of the member (11) to bend under longitudinal compression.

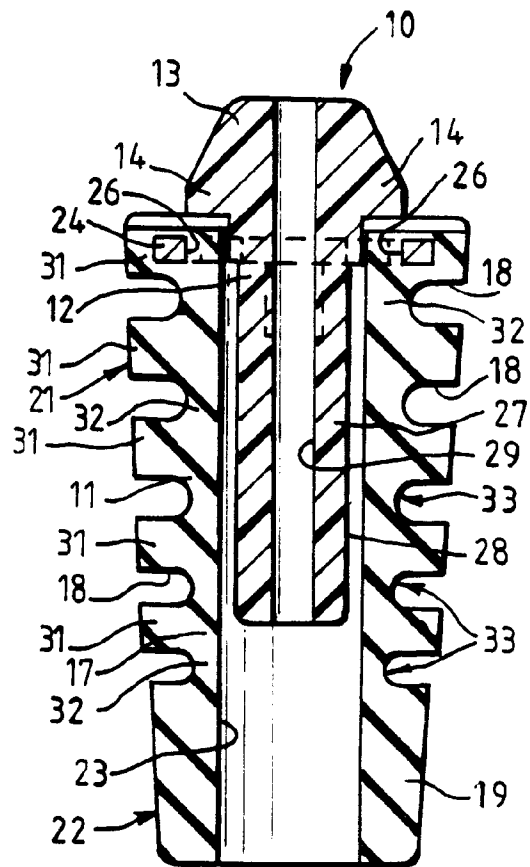

FIG. 4

This invention relates to a bump stop for use in a vehicle and in particular to a bump stop which is to be interposed between two body parts which are relatively movable towards and away from each other, such as between a vehicle trunk lid, tailgate, or door and a cooperating body section.

A bump stop may have a number of functions. It can serve as a buffer when the two body parts approach each other, so as to prevent damage to the parts. It can also serve as a damper between the two body parts when they are held adjacent to each other, so as to reduce noise and damage if one or both of the parts are subject to vibration. It can also bias the two parts away from each other, e.g. to assist the connection and disconnection of the two parts by means of a latching device.

It is known to provide bump stops between the trunk lid and the surrounding bodywork of a saloon car (and between the tailgate and the body of a hatchback or estate car). The conventional bump stop consists of a solid rubber element which is mounted in a channel in the part of the bodywork that frames the trunk opening and which is compressed by the lid (or tailgate) upon closing. However, during closing, the distance over which the lid travels while in contact with the rubber element is small, with the result that the buffering, damping, and latching/unlatching functions are not satisfactory. In particular, the solid rubber stop provides insufficient throw on unlatching of the trunk lid. Increasing the length (height) of the solid rubber stop causes it to become unstable and to tend to collapse sideways, resulting in poor performance and in possible dislodgement of the stop from its seating. If the base area is increased (e.g. by using a truncated conical stop) to provide stability, the footprint of the stop can become too large to be accommodated in the available space, which is usually limited to a rain channel on the vehicle.

Figures 1 and 2 of the accompanying drawings show a known form of bump stop which improves upon the conventional solid rubber element. This bump stop comprises a moulded rubber member 1 which has a head 2 designed for attachment to a trunk lid and which carries a relatively weak compression spring 3 acting on a disc 4. A flexible boot 6 covers the spring 3 and intended to render the bump stop weatherproof. As the lid is being closed, the spring 3 is compressed until the disc 4 comes into contact with an extension 7 of the rubber member 1, rendering the bump stop comparatively rigid.

However, although this bump stop can provide satisfactory buffering, damping, and latch/unlatching functions, it consists of an assembly of a relatively large number of individual parts and is therefore expensive to manufacture. Furthermore, the stop is located on the "wet side" of the vehicle, such as the trunk lid rain channel. Complete waterproofing is difficult to achieve and, hence, water ingress is com-

mon. This can cause corrosion and degradation of the metal parts, leading to premature failure in use.

What is desired is a bump stop which exhibits satisfactory performance in all the above-mentioned functions but which has a simple construction and therefore is easy and relatively inexpensive to manufacture.

The present invention provides a bump stop for interposal between two body parts of a vehicle which are relatively movable towards and away from each other, comprising: (a) an elongate hollow member which is longitudinally resiliently compressible from its unstressed length to a reduced length and is further longitudinally resiliently compressible from the reduced length to a compressed length, the resistance to compression at the unstressed length being less than the resistance to compression at the reduced length; and (b) an elongate support which extends part-way along a bore of the hollow member.

The elongate support resists any tendency that the elongate hollow member may have to bend when longitudinally compressed, but does not interfere with longitudinal compression of the hollow member.

Preferred and optional features are set forth in claims 2 et seq.

The invention will be described further, by way of example only, with reference to the accompanying drawings, in which:

Figure 1 is a side view of a bump stop for a vehicle in accordance with the prior art;

Figure 2 is an axial section on line II-II in Figure 1;

Figure 3 is a side view of a first embodiment of a bump stop for a vehicle in accordance with the present invention;

Figure 4 is an axial section on line IV-IV in Figure 3;

Figure 5 is a fragmentary diagrammatic side view of the trunk portion of a saloon car, showing a bump stop fitted on the trunk lid, in accordance with the invention;

Figure 6 is a graph of the compressive stress or load, L, on the bump stop of Figures 3 and 4 versus the compressive strain or axial deflection, D, suffered by the bump stop as the trunk lid is being closed;

Figure 7 is a side view of a second embodiment of the bump stop;

Figures 8 and 9 are axial sections through third and fourth embodiments respectively;

Figure 10 is a fragmentary axial section through a modification of the third or fourth embodiment; Figures 11 and 12 are axial sections through fifth and sixth embodiments, respectively;

Figure 13 is a fragmentary axial section through a modification of any of the above embodiments; Figure 14 is a fragmentary axial section through another modification of any of the above embodi-

ments; and

Figure 15 is an enlarged diagrammatic view in the direction of the arrow XV in Figure 14.

The bump stop 10 shown in Figures 3 and 4 comprises an elongate hollow member 11 and a holder 12 which has a head 13 with two opposed wings 14 enabling it to be fixed in a suitably shaped aperture in a trunk lid 16 (Figure 5).

The hollow member 11 is integrally moulded in one piece and consists of rubber, synthetic rubber, an elastomer, or any other resiliently compressible material, which may be an expanded or spongy material, if desired. The member 11 has an upper portion 17 containing peripheral grooves 18 and occupying a major part of the length of the member, and has a lower portion 19 which is slightly narrower and free of grooves. The upper, major portion 17 and the lower, minor portion 19 have respective external conically tapering surfaces 21,22 so that the member 11 narrows towards the bottom, i.e. away from the head 13. The member 11 has a substantially cylindrical bore 23.

The member 11 is moulded onto a flange or collar 24 which is integral with the head 13 and which has orifices 26 into which the material of the member 11 flows during moulding, so as to secure the holder 12 and the member 11 intimately together. The holder 12 itself is integrally moulded in one piece and consists of nylon, or another plastics material, which is rigid in comparison with the material of the hollow member 11. The holder 12 includes an elongate rod-like support 27 which extends part-way along the bore 23. Preferably the support 27 is cylindrical, and its external surface 28 is preferably spaced from the internal surface of the bore 23. The support 27 extends along a major part of the length of the bore 23 and, as can be seen in Figure 4, it extends along almost the whole of the length of the upper, major portion 17 of the hollow member. The holder 12 has an optional internal passageway 29 in the form of axial bore 29 which extends through the support 27.

The hollow elongate member 11 can be considered as comprising discs or rings 31 which have a comparatively high resistance to axial compression and intermediate zones 32 which have a comparatively low resistance to axial compression. The zones 32 are delimited by the grooves 18, which are of substantially constant depth, so that the radial dimensions of the zones decrease towards the bottom of member 11, i.e. they become weaker. Accordingly, the hollow member 11 has peripheral grooves 18 between annular portions or rings 31. The bases 33 of the grooves 18 are rounded so that they merge with the upper and lower surfaces of the rings 31. The rounded bases 33 help to spread loads at the groove/ring interface. (Squared-off grooves might be liable to fatigue cracking at the corners.)

The load/displacement (L/D) characteristic of the

bump stop is shown in Figure 6. As the trunk lid 16 approaches the trunk portion of the bodywork 34 the lower portion 19 of the bump stop comes into contact with the bottom of a channel 36 in the bodywork 34 and the member 11 begins to be elastically compressed. Initially the compressive strain occurs mainly in the relatively weak zones 32 and this corresponds to the shallow-gradient section 37 of the L/D characteristic (Figure 6). After the member 11 has been compressed to a reduced length by an amount corresponding to the combined thicknesses of the grooves 18, the rings 31 are substantially in face-to-face contact so that further compressive strain from this reduced length to a compressed length occurs only in the rings 31 and the lower portion 19, and this corresponds to the steep-gradient section 38 of the L/D characteristic. In Figure 6 the broken line 39 indicates the deflection (compression) of the stop at the point at which a latch (not shown) on the lid 16 comes into engagement with a striker (not shown) on the bodywork 34.

The support 27 resists the tendency of the elongate member 11 to bend when compressed. As the lid 16 is closed the tube-like member 11 tends to collapse sideways and the tubular bore 23 tends to bulge inwards locally until it engages the support 27. This prevents further collapse at that part of the tube. Continued compression of the member 11 causes collapse to occur at other locations, until the tubular bore 23 adopts in effect a serpentine shape engaging the support 27 at various points. Further sideways collapse of the tube-like member 11 is thereby prevented, and axial compression continues until the annular discs or rings 31 become plate-bound, whereupon the member 11 acts like a solid rubber stop.

The passageway 29 in the holder 12 communicates between the bore 23 of the hollow member 11 and the exterior. This prevents air being trapped in the bore 23 as the member 11 is longitudinally compressed between the lid 16 and the bodywork 34. The cross-section of the passageway 29 may be limited (locally or over some or all of its length) to provide additional damping during closure of the lid, and this damping can be tuned to specific applications (as described with reference to Figures 13 to 15 below). Additionally, as the bore 23 and the passageway 29 are in direct communication, a conduit is thus provided, extending the length of the stop. This ensures that any water entering the stop during service can readily escape.

Nylon is the preferred material for the holder 12, since it makes the support 27 sufficiently strong while making the head 13 sufficiently resilient to allow rapid mounting in an aperture. The head 13 and the support 27 can therefore be made as a unitary part. The provision of the apertured flange 24 near the head 13 allows the rubber member 11 to be moulded around the support 27, leaving a gap be-

tween the surface 28 and the bore 23, while the rubber flows into the orifices 26 so that the flange 24 is bonded very firmly into the rubber, which is very durable in use.

Figure 7 shows a second embodiment which is similar to the first embodiment except that the approximately annular discs or rings form a single helix 31' and there is a single helical groove 18'.

Figure 8 shows a third embodiment which is similar to the first embodiment except that the hollow elongate member 11 comprises separate annular discs or rings 31 and a separate annular lower portion 19 which are mounted on an axially compressible tube 30 (of rubber or the like). The rings 31 are bonded to the tube 30 and may each be located by a groove in the tube cooperating with a rib on the ring (or vice versa) as shown at 41 in Figure 8. The rings 31 can be made from resilient material of different hardness; by combining rings of various hardness, the compression characteristics of the bump stop can easily be tuned to suit particular applications.

Figure 9 shows a fourth embodiment which is similar to the third embodiment except that the rings 31 are of L-shaped radial section so that they abut against one another and automatically set the required heights of the grooves 18.

In each of the embodiments shown in Figures 8 and 9 the portion 19 is shrink-fitted or bonded onto the tube 30. Alternatively, as shown in Figure 10, the portion 19 and the tube 30 could have cooperating peripheral toothings 42 enabling easy fitting of the portion 19 to the tube 30 while preventing separation of the portion 19 from the tube.

Figure 11 shows a fifth embodiment which is similar to the first embodiment except that the upper, major portion 17 comprises a stack of dished washers 31" which are bonded together and to the lower, minor portion 19.

Figure 12 shows a sixth embodiment which is similar to the first embodiment except that the support 27 is separate from the holder 12 and has an integral flange 43 for mounting on the bodywork of the vehicle. Thus the support 27 enters the bore 23 through the lower portion 19 of the hollow member 11 during closing of the trunk lid.

Figure 13 shows a possible modification of any of the above described embodiments, in which an element 44 (which may be distinct from or integral with the head 13) defines a restricted orifice 46 in the passageway 29.

Alternatively, as shown in Figures 14 and 15, an orifice plate 47 may be provided for insertion in a recess 48 in the head 13. In particular, as shown in Figure 15, the plate 47 and recess 48 are circular and are off-centre with respect to the axis of the passageway 29. The plate 47 has an eccentric through-hole 49 which can overlap the passageway 29, the degree of overlap being adjustable (from zero to 100%, for ex-

ample) by turning the plate 47, which is preferably a friction fit in the recess 48. Angular adjustment is facilitated by a slot 51 for receiving a screwdriver. By this means, the registration of the hole 49 with the passageway 29 can easily be adjustable, in order to adjust the damping effect of this restriction of the passageway.

All the above-described embodiments are of simple construction and relatively low cost. They provide a bump stop with a dual stress/strain characteristic (Figure 6) and sufficient throw upon unlatching.

Claims

1. A bump stop (10) for interposal between two body parts (16,36) of a vehicle which are relatively movable towards and away from each other, the bump stop (10) comprising:
 - (a) an elongate hollow member (11) which is longitudinally resiliently compressible from its unstressed length to a reduced length and is further longitudinally resiliently compressible from the reduced length to a compressed length, the resistance to compression at the unstressed length being less than the resistance to compression at the reduced length; and
 - (b) an elongate support (27) which extends part-way along a bore (23) of the elongate hollow member (11), for resisting any tendency of the elongate hollow member (11) to bend when longitudinally compressed.
2. A bump stop as claimed in claim 1, in which the hollow member (11) comprises substantially annular portions (31) which have an axial spacing when the hollow member (11) is at its unstressed length and which are in mutual face-to-face contact when the hollow member (11) is at the reduced length.
3. A bump stop as claimed in claim 2, in which the hollow member (11) is a one-piece member.
4. A bump stop as claimed in claim 3, in which the hollow member (11) has a peripheral groove (18) between adjacent annular portions (31).
5. A bump stop as claimed in claim 4, in which the groove (18) has a rounded base (33) which merges with facing surfaces of the adjacent annular portions (31).
6. A bump stop as claimed in any of claims 3 to 5, in which the hollow member (11) has zones (32) of reduced radial thickness between the annular portions (31), the thickness of the zones de-

creasing along the hollow member (11).

7. A bump stop as claimed in any preceding claim, in which the elongate support (27) has an external surface (28) which, at the unstressed length, is spaced from the bore surface (23) of the hollow member (11). 5
8. A bump stop as claimed in any preceding claim, in which the length of the elongate support (27) is less than the compressed length of the hollow member (11). 10
9. A bump stop as claimed in any preceding claim, in which the elongate support (27) has an internal passageway (29) communicating between the bore (23) of the hollow member (11) and the exterior. 15
10. A bump stop as claimed in any preceding claim, including a flanged holder (12) connected to and surrounded by one end of the elongate hollow member (11), the holder (12) having internal passageway (29) communicating between the bore (23) of the hollow member (11) and the exterior. 20
25
11. A bump stop as claimed in claim 10, including a restricted orifice (46) in the passageway (29).
12. A bump stop as claimed in claim 10, in which the holder (12) has a recess (48) which overlaps the passageway (29) and which receives an orifice member (47) having a through-hole (49) capable of overlapping the passageway (29) to a variable extent depending upon the position of the orifice member (47) in the recess (48). 30
35
13. A bump stop as claimed in claim 12, in which the recess (48) and the orifice member (47) are circular and are eccentric with respect to the passageway (29), and the through-hole (49) is eccentric with respect to the orifice member (47). 40
14. A bump stop as claimed in any of claims 10 to 13, in which the holder (12) is integral with the support (27) and made of nylon. 45
15. A bump stop as claimed in any preceding claim, in which one of the body parts is a trunk lid (16) and the other part is a rain channel (36). 50

55

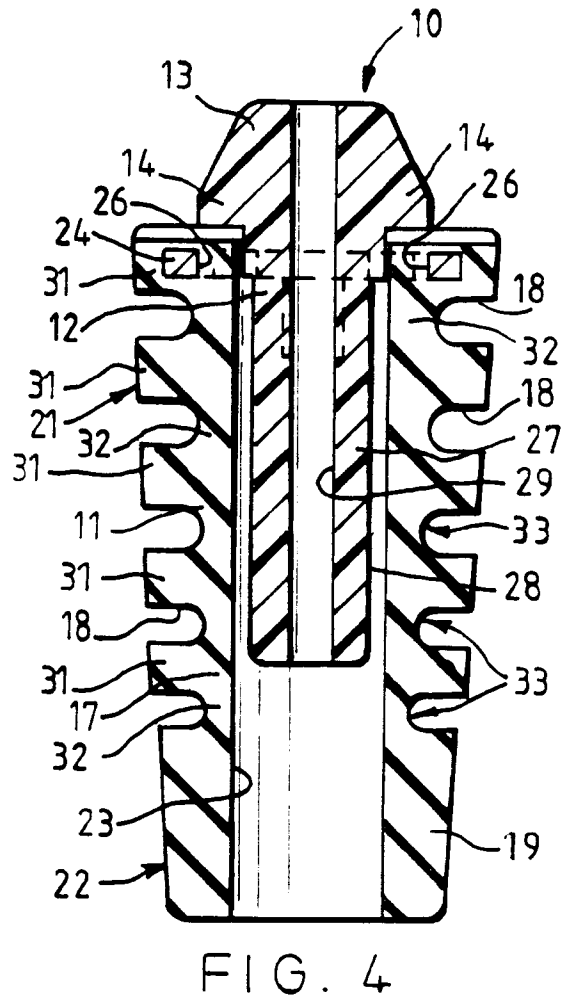
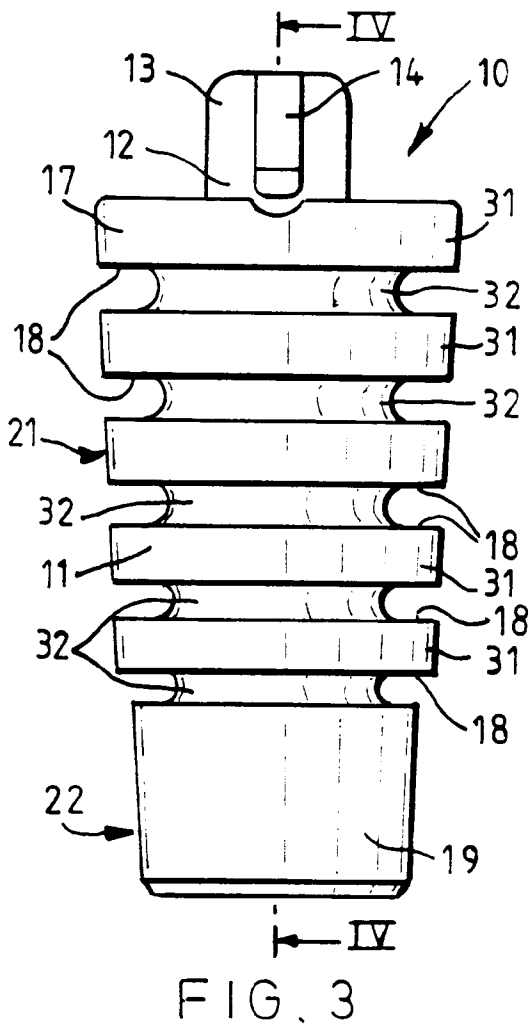
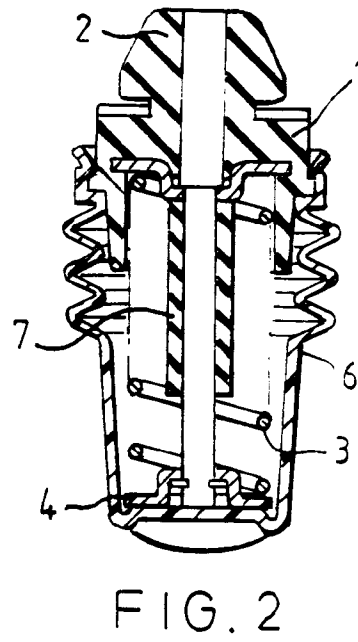
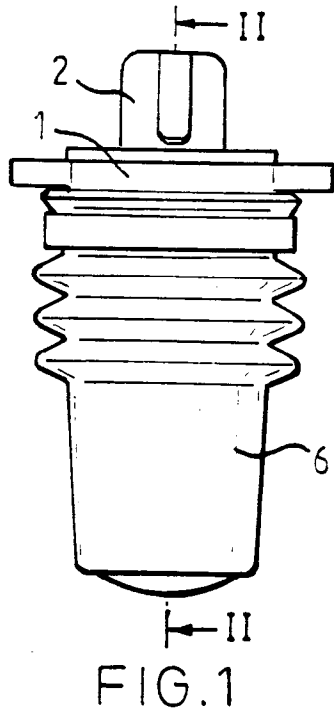

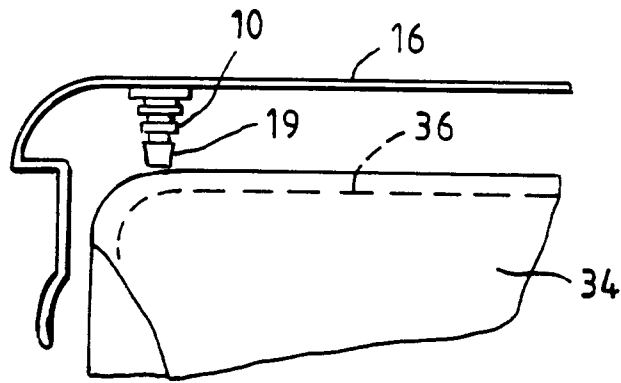

FIG. 5

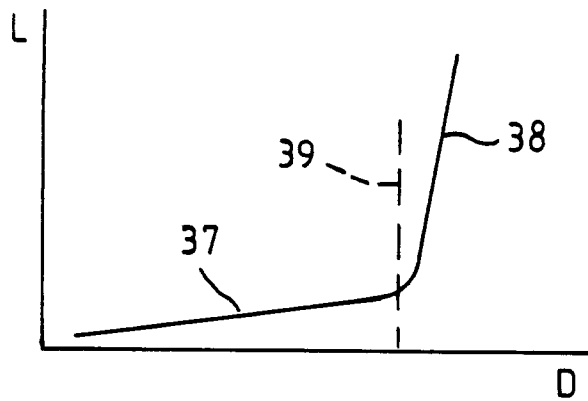

FIG. 6

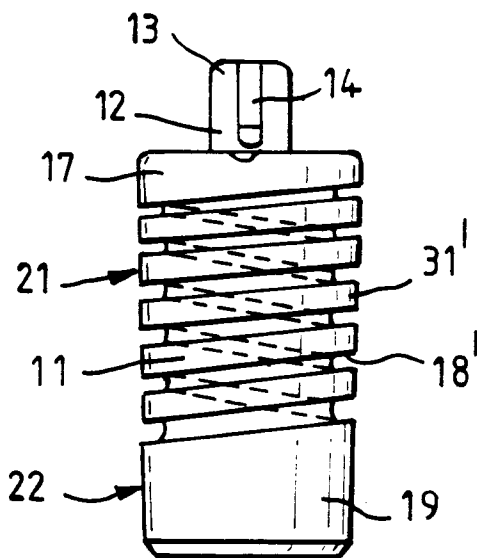

FIG. 7

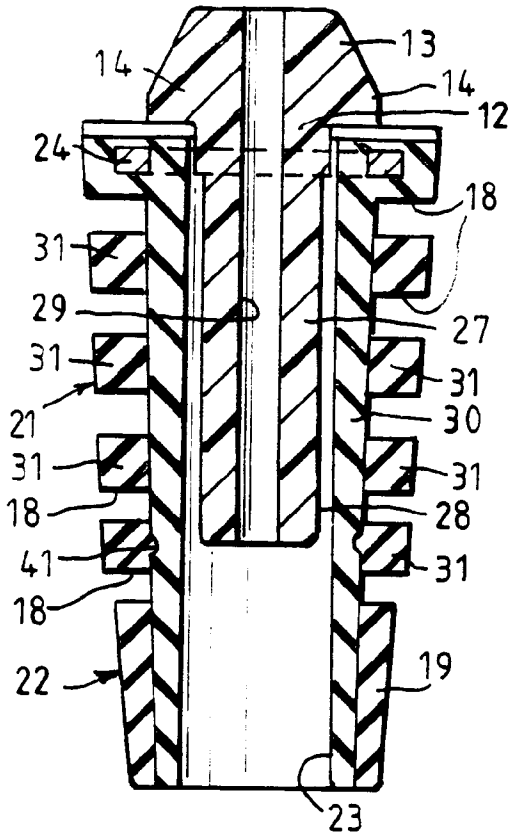

FIG. 8

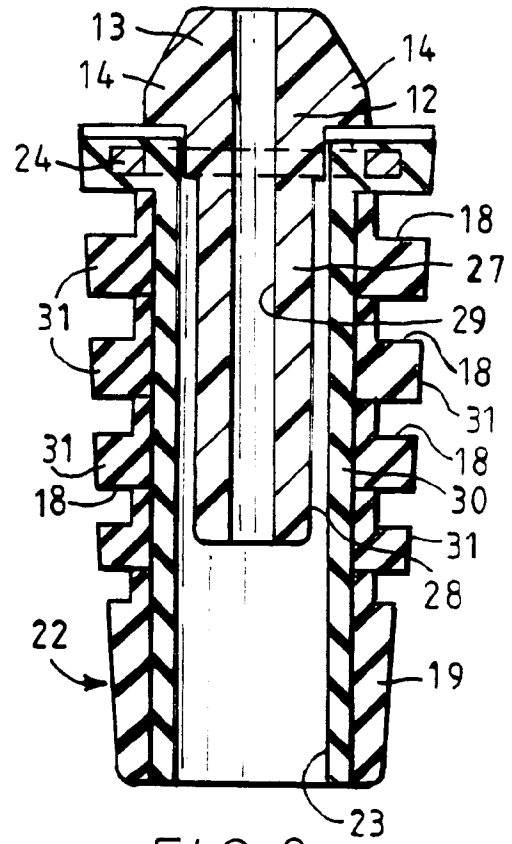

FIG. 9

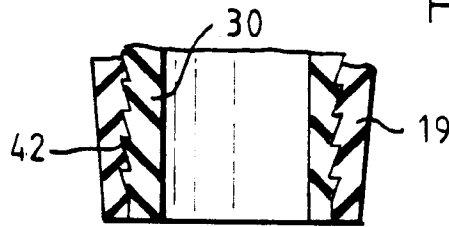

FIG. 10

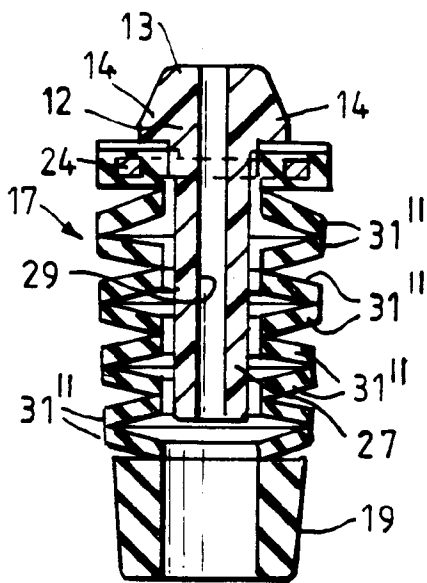

FIG. 11

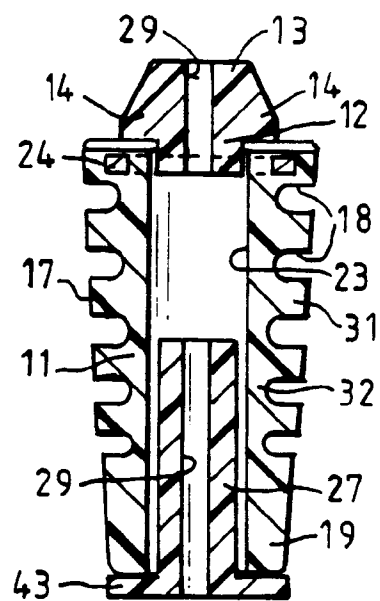

FIG. 12

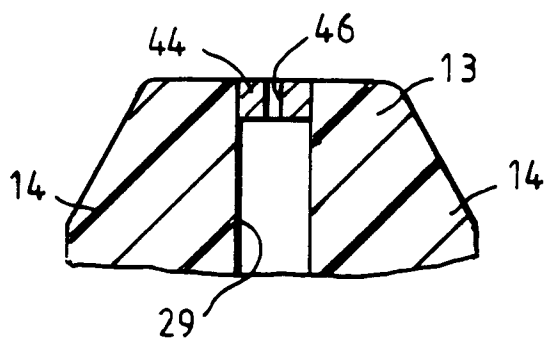

FIG. 13

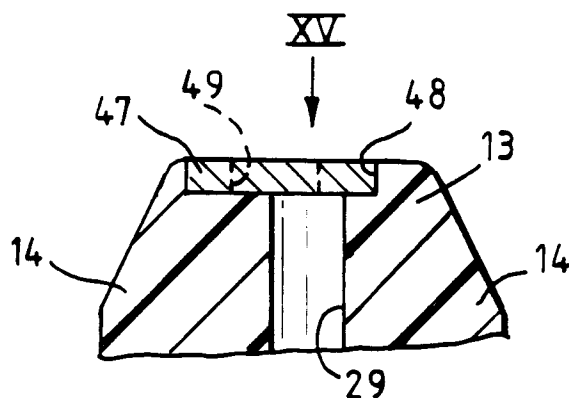

FIG. 14

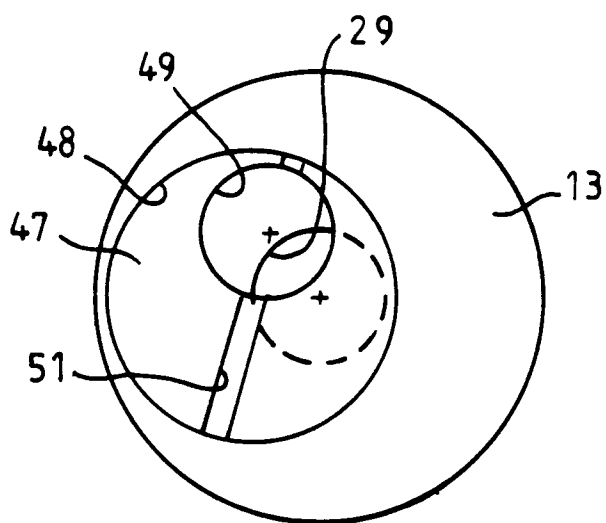

FIG. 15



European Patent
Office

EUROPEAN SEARCH REPORT

Application Number
EP 93 31 0423

DOCUMENTS CONSIDERED TO BE RELEVANT			
Category	Citation of document with indication, where appropriate, of relevant passages	Relevant to claim	CLASSIFICATION OF THE APPLICATION (Int.Cl.5)
A	PATENT ABSTRACTS OF JAPAN vol. 011, no. 175 (M-596)5 June 1987 & JP-A-62 006 825 (NISSAN MOTOR CO LTD) 13 January 1987 * abstract *	1	E05F5/06 B62D25/12
A	FR-A-2 565 649 (REGIE NATIONALE DES USINES RENAULT) * the whole document *	1	
A	DE-U-88 14 527 (K.K.P. KONSTRUKTIVE KUNSTSTOFF-PRODUKTE) * page 2, line 25 - page 3, line 6 * * page 6, line 1 - line 22; figures *	1	
			TECHNICAL FIELDS SEARCHED (Int.Cl.5)
			E05F B62D
The present search report has been drawn up for all claims			
Place of search		Date of completion of the search	Examiner
THE HAGUE		24 February 1994	Delzor, F
CATEGORY OF CITED DOCUMENTS			
X : particularly relevant if taken alone Y : particularly relevant if combined with another document of the same category A : technological background O : non-written disclosure P : intermediate document		T : theory or principle underlying the invention E : earlier patent document, but published on, or after the filing date D : document cited in the application L : document cited for other reasons & : member of the same patent family, corresponding document	

EPO FORM 1503 03/92 (P04C01)