

19



Europäisches Patentamt  
European Patent Office  
Office européen des brevets



11 Publication number:

**0 607 922 A1**

12

**EUROPEAN PATENT APPLICATION**

21 Application number: **94100655.3**

51 Int. Cl.<sup>5</sup>: **A45D 40/22**

22 Date of filing: **18.01.94**

30 Priority: **20.01.93 DE 9300702 U**

43 Date of publication of application:  
**27.07.94 Bulletin 94/30**

84 Designated Contracting States:  
**AT BE CH DE ES FR GB IT LI NL**

71 Applicant: **TECHPACK LAFFON GmbH**  
**Gestaltung und Vertrieb von kosmetischen**  
**Verpackungen**  
**Römerstrasse 15**  
**D-80801 München(DE)**

72 Inventor: **Blachut, Longin**  
**Riva Paradiso 32**  
**CH-6902 Paradiso(CH)**

74 Representative: **VOSSIUS & PARTNER**  
**Siebertstrasse 4**  
**D-81675 München (DE)**

54 **Make-up case with interchangeable inserts.**

57 The make-up case comprises a lower part (1), a frame (2) and a lid (4) which can be closed by a hinge. The frame (2) is releasably fixed to the lower part (1) by pins (5) in holes (6) on the side walls of a tray (not shown) as fixing means and fixes two inserts (3), which are arranged in the tray, in their position. In addition, the lower part (1) contains an applicator groove (7) which may receive applicators for applying the cosmetics.

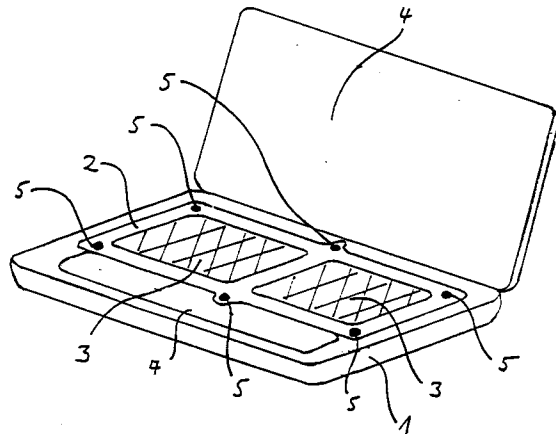

Fig. 1

**EP 0 607 922 A1**

The invention relates to a make-up case with interchangeable inserts for use in personal body care.

Such cases contain several inserts with cosmetics, for instance make-up colours, such as eye shadow, or powder. Different colours or powders are often simultaneously used, corresponding to for instance the individual preferences or needs of a user. The used cosmetics are replaced by new ones or the cosmetics are substituted with others, if necessary. In this connection, the inserts must be easily interchangeable and the number of available inserts should be variable.

Known make-up cases with interchangeable inserts are capsule-shaped and comprise a lower part, an intermediate part and a lid. The inserts are fitted into the lower part and fixed by the intermediate part. The lid closes the case. The lower part, the intermediate part and the lid are hinged to each other at one side and the intermediate part must be folded to the top in a curved manner for replacing the inserts.

The US-A-4 421 127 discloses a make-up case which comprises in its lower part crossing and projecting ribs which form substantially rectangular cavities between each other. The cavities receive correspondingly shaped inserts. Above them, an intermediate part is arranged that is hinged to one side of the lower part; said intermediate part fixes the inserts in the lower part and is turned to the top in a curved manner when the inserts are replaced. On the same side of the lower part a lid is hinged for opening and closing the make-up case. This make-up case has the drawback that the preformed grooves of the lower part and the correspondingly adapted intermediate part, which is fixed to the case, predetermine the shape and the number of the used inserts. Thus, new cases must be used if the shape or the number of the inserts are changed.

In contrast to this, the object underlying the invention is to provide a make-up case which can receive different shapes and a different number of inserts and which has a simple and inexpensive structure.

This object is achieved with the features of the claims.

The solution of the problem underlying the invention is based on the idea to refrain from providing the tray for receiving the inserts in the lower part of the case with particular structures, such as recesses for fitting in the inserts, and to fix the inserts in the tray by a frame which is adapted to the desired shapes of inserts. This frame is releasably and firmly fitted into the case, for instance by pins in the frame and corresponding holes in the case tray. If desired, it can be easily replaced by another frame for other shapes or a

different number of inserts.

The invention has the following advantages:

The make-up case according to the invention has manifold uses. Different shapes and a different number of inserts can be housed in a basic case model. A corresponding frame design allows the provision of different embodiments of the make-up case interior which meet individual fashion requirements. The frame is simple and inexpensive to produce. It is interchangeable and can be easily released from the case and re-fixed in it.

In the following, the invention is illustrated in more detail with reference to the drawings.

Fig. 1 shows a perspective view of an embodiment according to the invention,  
 Figs. 2a to 2h show different embodiments of the frame according to the invention,  
 Fig. 3 shows a side view of an embodiment of the frame according to the invention,  
 Fig. 4 shows a top view of an embodiment of the tray according to the invention, and  
 Fig. 5 shows an enlarged cross section along the line A-A' in Fig. 3.

Fig. 1 shows a perspective view of the make-up case according to the invention. It comprises a lower part 1, a frame 2 and a lid 4 which can be closed by a hinge. The frame 2 is releasably fixed to the lower part 1 by pins 5 in holes 6 on the side walls of a tray (not shown) as fixing means and fixes two inserts 3, which are arranged in the tray, in their position. In addition, the lower part 1 contains an applicator groove 7 which may receive applicators for applying the cosmetics.

In addition to the frame 2 shown in Fig. 1, illustrated in Fig. 2a, further embodiments are possible (Figs. 2b to 2h). In this connection, preferably only the interior of the frame 2 is changed since the fixing means of the frame 2 to the lower part 1 is generally uniform in a specific basic model of the make-up case. The different segments, which are formed by separating ribs 2a of the frame 2, correspond to similarly shaped inserts 3.

Fig. 3 shows a side view of an embodiment of the frame 2 according to the invention as shown in Figs. 1 and 2a. Pins 5 are arranged in it for engagement with fitting holes in the side wall of the tray according to the invention.

Fig. 4 shows a top view of the tray 8 with side walls 9 and holes 6 for the pins 5 as well as the applicator groove 7. The holes 6 receive the pins 5 in a snap-in connection. The side walls 9 may be inserted into the lower part 1 by the amount of the thickness of the frame 2, in order to ensure a

smooth surface of the lower part 1 after superimposing the frame 2.

Further embodiments of the tray and the fixing means for the frame are, however, possible.

For instance, the tray may have an oval or a circular shape. The fixing means may comprise e.g. springs which press onto the frame, or lateral projections at the frame and lateral recesses in the side wall of the tray which allow a lateral snapping-in of the frame into the side walls or the tray.

Fig. 5 shows an enlarged rectangular cross section of a portion of an embodiment of the frame 2 according to the invention which fixes the inserts.

At the side facing the inserts, the frame 2 engages with corresponding recesses at the upper edge of the inserts, holds them from above and thus prevents them from being displaced.

However, the inserts can also be fixed by the frame in other ways. For instance, the side of the frame may be conically inclined towards the top and engages with a correspondingly inclined side wall of the inserts. In addition, the frame may only be partly engaged with the inserts.

#### Claims

1. Make-up case with interchangeable inserts, comprising
  - a) a lower part (1) with a tray (8) formed therein,
  - b) a lid (4) which is hinged to the lower part (1) and opens or closes the make-up case by pivoting,
  - c) a plurality of inserts (3) which are arranged in the tray (8), and
  - d) a frame (2) fixed to the tray (8) for holding the inserts (3) in the tray,

**characterized in that**

  - e) the frame (2) is releasably fixed to the tray.
2. The make-up case according to claim 1, **characterized in that** the frame (2) engages with recesses in the upper edge of the side walls of the inserts (3).
3. The make-up case according to claim 1 or 2, **characterized in that** the frame (2) is provided with pins (5) which engage with holes (6) in the side walls (9) of the tray (8), preferably by a snug fit.
4. The make-up case according to any one of claims 1 to 3, **characterized in that** the frame (2) comprises in its interior separating ribs (2a) corresponding to the shape of the inserts (3).
5. The make-up case according to any one of claims 1 to 4, **characterized in that** the lower part (1) comprises an applicator groove (7).



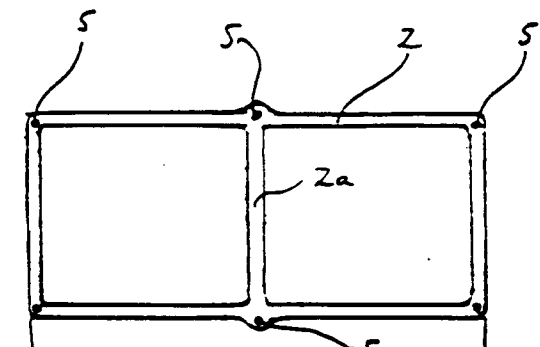

Fig. 2 a

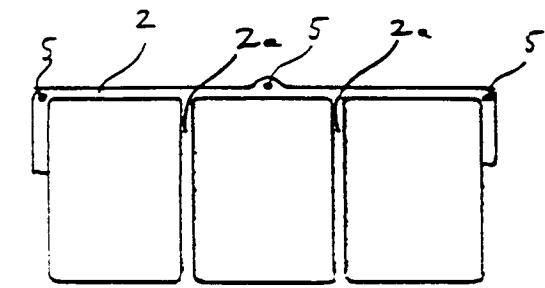

Fig. 2 b

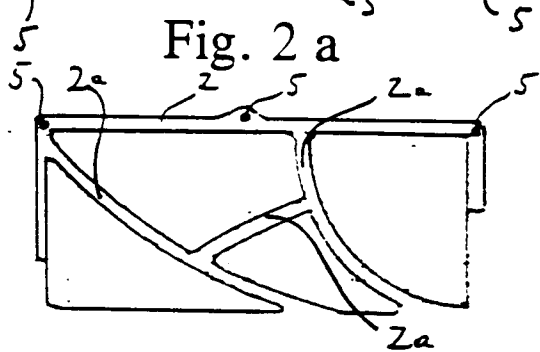

Fig. 2 c

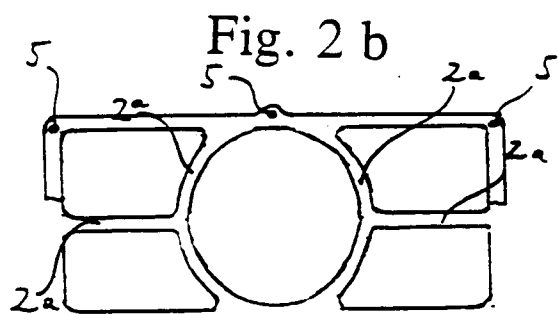

Fig. 2 d

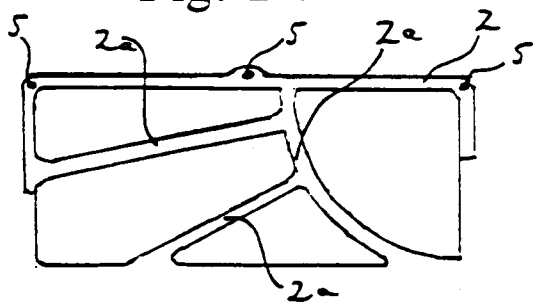

Fig. 2 e

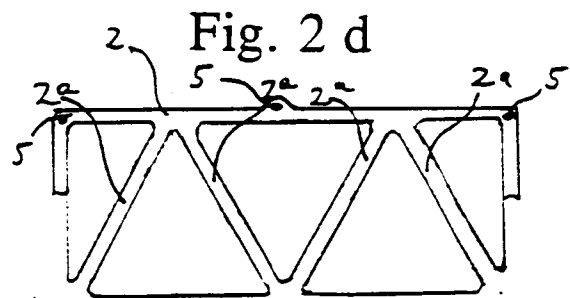

Fig. 2 f

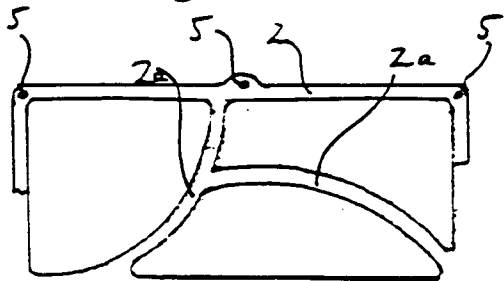

Fig. 2 g

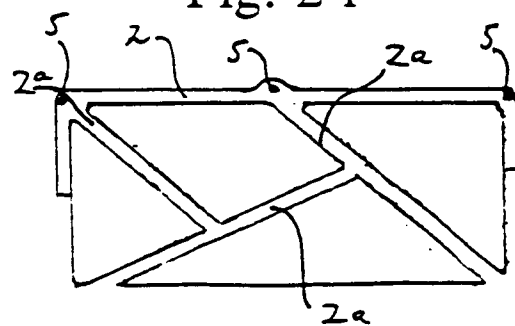

Fig. 2 h

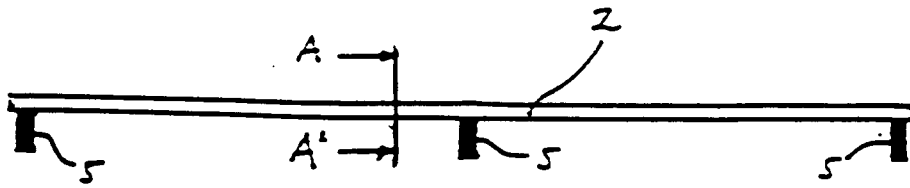

Fig. 3

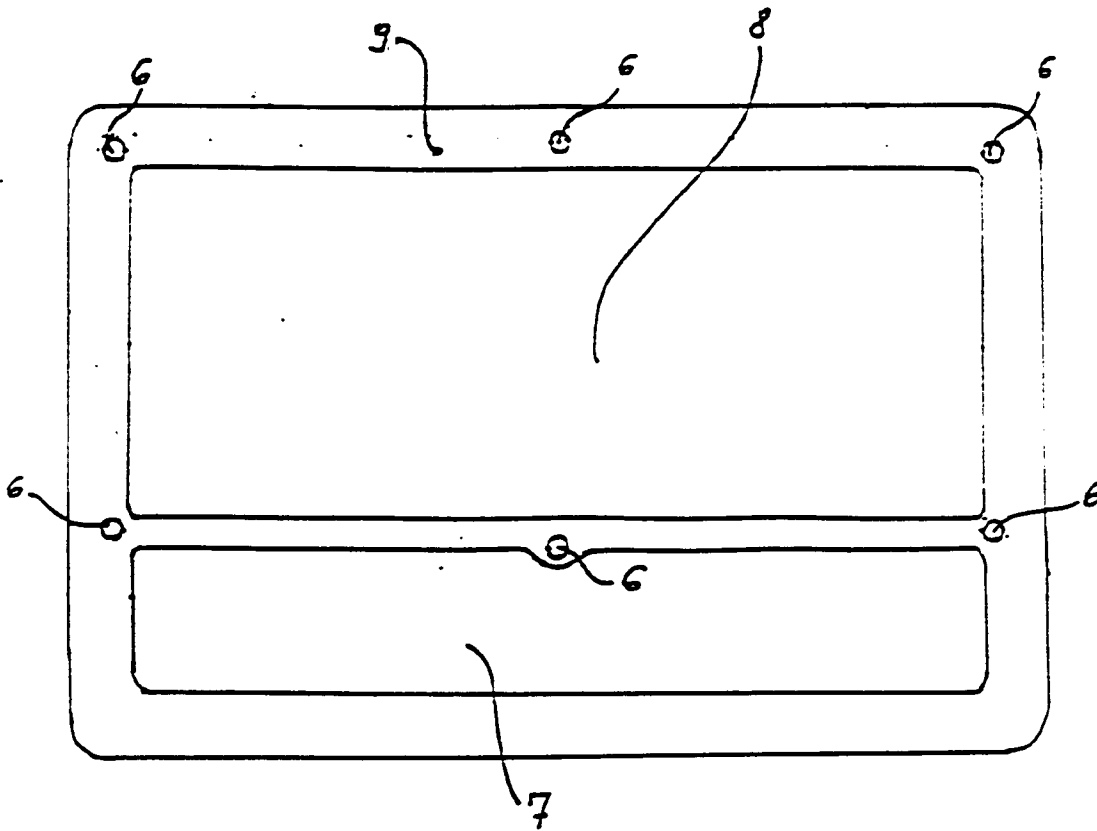

Fig. 4

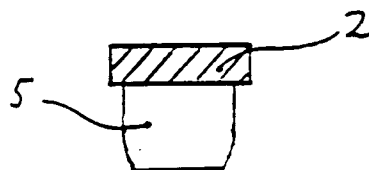

Fig. 5



DOCUMENTS CONSIDERED TO BE RELEVANT			
Category	Citation of document with indication, where appropriate, of relevant passages	Relevant to claim	CLASSIFICATION OF THE APPLICATION (Int.Cl.5)
D,X	US-A-4 421 127 (GEER) * column 3, line 20 - column 4, line 34; figures 1-7 * ---	1-5	A45D40/22
X	FR-A-695 089 (WERTHEIMER) * page 1, line 48 - page 2, line 36; figures 1-4 * ---	1,4	
X	GB-A-2 217 299 (WHEELER) * page 4, paragraph 2 - page 6, paragraph 2; figure * ---	1,4,5	
A	EP-A-0 038 645 (KOLMAR LABORATORIES) * page 4, paragraph 1 - paragraph 5; figures 1,2,8 * ---	1,3	
A	US-A-4 964 526 (STEPHENS) -----		
			TECHNICAL FIELDS SEARCHED (Int.Cl.5)
			A45D
The present search report has been drawn up for all claims			
Place of search		Date of completion of the search	Examiner
THE HAGUE		4 May 1994	Williams, M
CATEGORY OF CITED DOCUMENTS			
X : particularly relevant if taken alone		T : theory or principle underlying the invention	
Y : particularly relevant if combined with another document of the same category		E : earlier patent document, but published on, or after the filing date	
A : technological background		D : document cited in the application	
O : non-written disclosure		L : document cited for other reasons	
P : intermediate document		& : member of the same patent family, corresponding document	