

(19)



Europäisches Patentamt
European Patent Office
Office européen des brevets



(11)

EP 0 617 872 B1

(12)

EUROPEAN PATENT SPECIFICATION

(45) Date of publication and mention
of the grant of the patent:

28.01.1998 Bulletin 1998/05

(21) Application number: **92925487.8**

(22) Date of filing: **09.12.1992**

(51) Int Cl.6: **H04N 7/18**

(86) International application number:
PCT/US92/10468

(87) International publication number:
WO 93/12614 (24.06.1993 Gazette 1993/15)

(54) **VIDEO IMAGING METHOD AND APPARATUS FOR AUDIENCE PARTICIPATION**

VERFAHREN UND EINRICHTUNG ZUR VIDEOANZEIGE MIT ZUSCHAUERBETEILIGUNG

PROCEDE ET APPAREIL D'IMAGERIE VIDEO SOLLICITANT LA PARTICIPATION DES
SPECTATEURS

(84) Designated Contracting States:
**AT BE CH DE DK ES FR GB GR IT LI LU MC NL
PT SE**

(30) Priority: **10.12.1991 US 806051**
19.11.1992 US 978612

(43) Date of publication of application:
05.10.1994 Bulletin 1994/40

(73) Proprietor: **CARPENTER, Loren C.**
Novato, CA 94947 (US)

(72) Inventor: **CARPENTER, Loren C.**
Novato, CA 94947 (US)

(74) Representative:
Reinhard - Skuhra - Weise & Partner
Postfach 44 01 51
80750 München (DE)

(56) References cited:

EP-A- 0 445 459	US-A- 3 396 945
US-A- 4 249 207	US-A- 4 555 724
US-A- 4 565 999	US-A- 5 001 557
US-A- 5 115 230	

EP 0 617 872 B1

Note: Within nine months from the publication of the mention of the grant of the European patent, any person may give notice to the European Patent Office of opposition to the European patent granted. Notice of opposition shall be filed in a written reasoned statement. It shall not be deemed to have been filed until the opposition fee has been paid. (Art. 99(1) European Patent Convention).

DescriptionBACKGROUND OF THE INVENTIONField of the Invention

This invention relates generally to the arts of computer graphics and electronic image processing, and more specifically to the field of human-computer interface techniques for a group (one or more) of people simultaneously interfacing to one computer, and particularly to a method and system for collecting data from a plurality of persons being simultaneously present in a room.

DESCRIPTION OF THE PRIOR ART

Much work has been done in recent years to facilitate the one-on-one interaction of a human and a computer. This interaction is bidirectional, human-to-computer and computer-to-human. The present invention relates to the human-to-computer direction.

Devices commonly available for this purpose include computer keyboards, mouse, light pen, trackball, microphone, and, through the MIDI communication channel, a wide variety of musical instruments. In a situation where more than one person wishes to communicate to a computer simultaneously, as in, for example, the case of an audience controlling the course of a movie story, prior art has little to offer. The only techniques available fall into two similar categories: wired seats and radio transmitters.

Wired seats refers to the placement, at several or all seats in a room, of some kind of electronic signalling device consisting variously of buttons, switches, dials, etc. These devices are connected via wires to a computing or tabulating device which registers the actions made by the people occupying the seats. This method is often used to tabulate votes in legislative bodies, and to record subject reactions in the testing of television commercials. It, of course, requires significant advance preparation of the room, which may not be convenient or possible in many cases.

The laying of wires in the room can be avoided by the second prior art method, wireless communication.

Here, the seats, or the people individually or in groups, are provided with signalling devices connected to a radio or infrared transmitter. Some form of multiplexing is employed to keep all the signals separated. The wireless method has the advantage that no wires need to be run, and, in addition, the people may be free to mill about in the area, not being confined to their seats. This method has the disadvantage of cost, transmitters and receivers costing far more than wires, with the attendant potential losses if transmitters are handed out to members of an audience. Also there are practical limits to the number of simultaneously transmitting devices, especially if low cost and/or low power are con-

siderations.

EP-A-0 445 459 discloses an apparatus for monitoring an individual performing as a test subject who has been placed within a room and is reading a magazine.

5 This known apparatus comprises a camera means and a means to direct light from an eye of said individual and from said magazine to said camera means. Moreover, means for adjusting the orientation of a field of view of said camera means to enable monitoring of the eye of
10 the individual and magazine being read by the individual are provided. However, this known apparatus does not allow to collect data from a plurality of persons at the same time.

15 SUMMARY OF THE INVENTION

It is a general object of the present invention to provide a method and system whereby a plurality of persons may simultaneously communicate information to a
20 computer, using simple devices of minimal cost.

This object is achieved by the method defined in claim 1 and the system defined in claim 15, respectively.

Preferred embodiments are listed in the respective dependent claims.

25 According to a preferred embodiment of the invention each member of an audience is equipped with a retro-reflective device each one of which is illuminated by one lamp and viewed by one video camera, substantially co-axially aligned with the lamp, a signal from the video
30 camera being analyzed and acted upon by a computer.

Thus in accordance with an embodiment of the invention an audience response system is provided in which each audience member is provided with a reflective device which is for instance green on one side and
35 red on the second side. Light from a source of light is reflected from the individual reflectors and imaged by a conventional video camera. A computer connected to each camera via a frame grabber forms a map of the audience and distinguishes the individual red from
40 green reflections. This red and green reflection image data is then processed by the computer and used, for instance, for voting by the audience and/or to project an image onto a screen visible to the audience, the image being controlled in terms of some particular parameter
45 by the number and/or location of the red or green image reflections which are aggregated by the computer.

In an alternate variation of the invention, members of the audience are equipped with self powered sources of illumination (such as flashlights), the video image of
50 which is analyzed by the computer in an identical manner.

In another embodiment, the direction or velocity of movement of each reflective device or light source is used to produce the video image or communicate information, allowing for instance group control of a cursor
55 on the computer screen. Also, each device or light source may uniquely identify itself by sending coded information.

BRIEF DESCRIPTION OF THE DRAWINGS

Figure 1 shows the operator station and related portions of a system in accordance with the invention.

Figures 2a, 2b and 2c show the system of Figure 1 in use.

Figure 3 shows reflection of light in accordance with the invention.

Figure 4 shows a camera image in accordance with the invention.

Figure 5 shows a grid pattern for analyzing light reflection.

Figures 6 and 7 show polygons for defining image locations.

Figure 8 shows a polygon summing system in accordance with the invention.

Figures 9a and 9b show two methods of using the polygon summing circuit of Figure 8.

DETAILED DESCRIPTION OF THE INVENTION

Figure 1 shows the operator control station and associated portions of a system in accordance with the invention. A conventional personal computer includes monitor 10, keyboard 12, CPU 14 (central processing unit), disk 16, and main memory 18. Provided as a conventional add-on board to the computer is a conventional video frame grabber 22 such as the commercially available model AT-Vista from TrueVision, Inc. Frame grabber 22 accepts conventional video data from a conventional color RGB or composite video camera 24. Other output modes in accordance with the invention include a computer controlled laser video disk playing a movie or a multimedia file under the control of the audience, or MIDI, or other modes of feedback to the audience.

Also connected to the computer is a graphics display control unit 26 such as a standard VGA adapter card which provides images generated by the CPU 14 to a conventional graphics monitor 28 and a conventional video projector 30.

As shown in Figure 2a, the video projector 30 conventionally projects images from the computer CPU 14 onto a screen 34 for viewing by members of an audience who are sitting, for instance, in an auditorium on chairs 36-1, 36-2, 36-3, ..., 36-i ..., 36-k, only some of which are shown. It is understood that the audience is filling or partially filling the auditorium, and need not be seated; chairs 36-1, ..., 36-k merely represent locations of the members of the audience. A light source 40 (such as a floodlight) is coaxially mounted with video camera 24, which is mounted so as to receive light reflected from retro reflectors (not shown) held by each audience member in seats 36-1, ..., 36-k. The light preferably illuminates just what the camera images and no more.

The overall setup is as shown therefore in Fig. 2a, although alternative setups as shown in Fig. 2b and Fig. 2c with camera 24 and light source 40 located as shown

can be used with no other changes.

Members of the audience are each equipped with a retroreflecting device. These retroreflecting devices in one version are constructed by applying adhesive backed retroreflecting tape (commercially available from 3-M or Reflexite Corp.) to a small flat stick of wood or stiff paperboard. Such tape returns a reflection only towards the incident light source, thus the requirement for collocating the light and camera when retroreflectors are used. In one version, about six square inches each of red and green tape (each measuring about 2" x 3") are applied respectively to opposite sides of one end of the stick. In the preferred embodiment the auditorium is darkened like a movie theater.

This configuration allows each participating person in the audience to signal by holding up the stick, with the retroreflecting tape in view of the video camera(s).

Fig. 3 shows the relationship between the light source 40, one such retroreflecting device 44, and the video camera 24. A simple turn of the wrist by the person holding the retroreflecting device 44 is sufficient to change the state of the signal value observed by camera 24 by changing from the red side of device 44 being towards the camera 24 to the green side of device 44 being towards the camera 24.

A typical image of an audience as seen by the video camera 24 is shown in Fig. 4. If the auditorium (stadium, etc.) is large, several video camera 24/light source 40 combinations (see Figure 3) are disposed at convenient locations around the auditorium, so as to cover the entire audience. The number of camera 24/light source 40 combinations, the size of each reflector 44, and the ambient room light level may be varied so as to achieve a satisfactory image at camera 24 to enable each reflecting device to be imaged. The image (Figure 4) consists of a varying number of colored dots, 50-1, 50-2, 50-3, ..., 50-i, ..., 50-n, generally moving slightly, each colored dot being the image of one reflector. Software resident in the computer analyzes this time-dependent imagery to determine the state of each of the audience members' reflectors. The video camera's perspective transformation matrix describes how reflectors in the room are transformed into points 50-1, ..., 50-n in the video image. This matrix is derived for each camera 24 when it is emplaced, before use with the audience. A computer program for performing this process is shown in the microfiche appendix which is part of this disclosure. The computer program is in the C language and annotated with comments explaining operation thereof.

Derivation of the matrix in the program is done via a least-squares technique by associating the known locations of specially located reflectors in view of the camera(s), with the resulting positions of said reflectors in the video image(s) of each camera 24. The correspondence so derived allows one to predict the location in the video image of any point (i.e., each seat 36-1, ..., 36-k) within the view of the camera 24. Given the layout of the seats 36-1, ..., 36-k in the auditorium and the probable

offset of a typical reflector from the associated seat, the transformation matrix permits the computation of the pixel location of each audience member's reflector in the video image of the audience.

Alternatively, the seat geometry matrix may be overlaid with a sampling mesh (see Figure 5), with each cell 52-1, 52-2, ..., 52-i, ..., 52-k the size of approximately the dimensions of one or more seats. This alternative may also be used where no seats are present (the audience is milling around), or if the seating geometry is not available to the computer.

Given the probable location of the expected dots (see Figure 4) in the video image of each video camera in a large auditorium where several cameras are used, each seat may be assigned to a camera capable of the best view, e.g. the dot is closest to the center of the image for that camera.

Also, given the probable location of the dots in the video image, a polygon, rectangular or otherwise, can be defined surrounding the dot in the video image. Figures 6 (rectangles) and 7 (Voronoi polygon tiling) show exemplary configurations of such polygons 56-1, 56-2, ..., 56-i, ..., 56-n. Figure 6 shows rectangular polygons 56-1, ..., 56-n; Figure 7 shows voronoi polygon tiling 56-1, ..., 56-n. Given the polygon definitions, the computer then continuously sums the digital values inside each polygon 56-i in the image, for each color. The resulting sums indicate the relative amount of each color emanating from the region surrounding the probable location of a reflector held by a participant. If the sums are greater than a predefined threshold, a simple test of relative magnitude can determine the color of a participant's reflector.

If the sums are all below the threshold, the participant is deemed to be sending no signal. The states of the participants' reflectors are then made available to the other subsystems of the computer system.

In another embodiment, rather than processing the above-described polygon 56-1, ..., 56-n definitions by computer software, instead a circuit implementation is provided for faster processing, i.e., faster response time, to changes in the reflector states. This circuit replaces the frame grabber 22 in the system of Figure 1. Its function is to act as a frame grabber and data concentrator to reduce the volume of input data. It allows the host computer to be free to perform other tasks such as generating images or music. Figures 9a and 9b (described below) show two methods of using the summing circuit. This circuit advantageously provides a response time with only a two video frame time delay, i.e., approximately 1/15th of a second or less. This "polygon summing" circuit in one version is a board conventionally installed in the computer central processing unit 14 or may be a stand-alone unit.

The polygon summing circuit is shown as a block diagram in Figure 8. There are two video channel inputs video 1, video 2. Video 1 would be, for instance, for the red color image detected by the video camera and video

2 would be for instance the green color image detected by the video camera. These images video 1 and video 2 are each digitized respectively by 10-bit analog to digital converter 64-1, 64-2 and then each processed respectively by a static RAM look-up table (lut) 66-1, 66-2 to form 8-bit data, to overcome any nonlinearities in the video input signal and to compensate for illumination color imbalances, camera gain differences, and reflector efficiency differences.

The circuit operates at any one time in one of two modes. The first mode is continuously digitizing and storing the two channels of video. The second mode is, for each of the two channels, summing polygons defined in their frames.

The digitizing mode operates in the following manner. At the beginning of a frame as determined by sync stripper 80, and clocks, timing, and control circuitry 82, addresses for the VRAM (video RAM) 78 are reset to the beginning of the frame. VRAM 78 is 1024 x 512 x 16-bits. For each pixel and each scan line, the control circuit 82 causes the following to happen in this sequence: analog to digital converters 64-1, 64-2 each clocks its value out respectively to look-up table 66-1, 66-2, each of which converts the digital value to 8 bits. Each 8-bit latch 68-1, 68-2 holds the output respectively of look-up table 66-1, 66-2. Sixteen bit buffer 76 connects the output of both latches 68-1 and 68-2 to the serial port of VRAM 78.

The control circuitry 82 presents the address and write strobe to VRAM 78 and the pixels from buffer 76 are stored therein. The control circuitry 82 increments the VRAM 78 address. At that time, the host computer (which is connected thereto by a host computer interface with read-write access to all memories) can read the pixels in the VRAM 78 through the VRAM 78 random access port (not shown).

The polygon summing mode of the circuit of Figure 8 operates in the following manner. At the beginning of a frame as determined by sync stripper 80 and control circuitry 82, the addresses for VRAM 78 are reset to the beginning of the frame. For each pixel and each scan line, the control circuit 82 causes the following to happen in this sequence. Each analog to digital converter 64-1, 64-2 clocks its value out. Each look-up table 66-1, 66-2 converts the received digitized value to 8 bits. Each latch 68-1, 68-2 holds the output respectively of look-up table 66-1, 66-2.

Control circuitry 82 presents the address and read strobe to VRAM 78 and a polygon number is read out of the serial port of VRAM 78.

Each SRAM (static RAM) 74-1, 74-2 stores two banks of 32K 16-bit words. Each SRAM 74-1, 74-2 uses the read out polygon number as its address. The word in SRAMs 74-1, 74-2 at this address is read out respectively into latches 72-1, 72-2, of which is a 16-bit latch. Each 16-bit adder 70-1, 70-2 computes the sum of the converted pixel respectively in latch 68-1, 68-2 and the partial sum in latch 72-1, 72-2. The sum from each adder

70-1, 70-2 is written back respectively into SRAM 74-1, 74-2 at the same address from which it was read. Control circuitry 82 increments the VRAM 78 address.

At the end of each frame the following happens in this sequence: SRAM 74-1, 74-2 banks are switched by control circuitry 82. The host computer (not shown) reads the contents of the previously updated bank of each SRAM 74-1, 74-2. The host computer then zeroes the contents of the previously updated bank of each SRAM 74-1, 74-2. The VRAM 78 is previously set-up to contain a polygon index for every pixel in the frame. Thus rectangles (or alternatively Voronoi tessellations) are easily supported for defining the cells as shown in Figures 6 and 7.

In use the circuit of Figure 8 operates as follows. First, it is operated in the above-described digitizing mode, with both lut's 66-1 and 66-2 containing a straight linear mapping of 10 onto 8 bits. Color calibration targets are placed so as to be in view of the camera and illuminated by whatever lights will be used with the audience. Video frames are digitized and read out by the host computer. The host computer determines adjustments to the lut's 66-1, 66-2 required to compensate for any imbalances in color response.

Second, the system is operated again in digitizing mode, this time with the corrected tables loaded in lut's 66-1, 66-2. During this phase, video frames are captured of calibration reflectors located in the room, i.e., nominal reflectors used to set up and aim each of the cameras by imaging their reflections. The host computer reads out the images of the calibration reflectors and finds the location in the images of the colored dots made by the reflectors. Then, these locations are matched with the measured physical locations of the corresponding reflector located in the room. Together, this provides sufficient information to compute the transformation matrix for the camera. This matrix allows the computer to predict where in the camera image the dot from an audience member is likely to be found. Sampling cells are derived surrounding the expected locations of these dots. Each sampling cell is numbered. The numbers of these cells are stored in the VRAM 78, with each VRAM 78 pixel being associated then with a particular cell number. For instance the cells are as shown in Figure 6 or 7. As the digitized pixel data from the video camera arrives in latches 68-1, 68-2, corresponding information is extracted from VRAM 78 indicating the cell number assigned to that particular pixel. Thus a unique identifier is provided for each cell and identification of each pixel with a particular cell is achieved.

After completion of these calibration phases, the system is used in conjunction with actual audience participation in the above-described summing mode. For each incoming pixel, the 15 data bits identifying the associated cell are clocked out and serve as an address for the SRAMs 74-1, 74-2 from the VRAM 78. In this example, 15 bits are chosen so as to allow use with a large audience, i.e., up to 32,768 people (cells) for 15

bits. The SRAMs 74-1, 74-2 are each then accessed and the data from the SRAMs 74-1, 74-2 goes respectively to latches 72-1, 72-2. Thus there is a read/modify/write cycle of the SRAMs 74-1, 74-2 for each of the up to 32,768 cells in the audience. There are two banks of static RAM in each SRAM 74-1, 74-2 with each frame swapped between the two banks. At the end of each video frame as identified by sync stripper 80 and control circuitry 82, the bank of each SRAM 74-1, 74-2 just accessed notifies the host computer to switch to the other static RAM bank. Thus the sum of the polygons (cells) is read out and that particular static RAM bank is cleared, i.e., returned to zero. The data from the SRAMs 74-1, 74-2 is then read out to the computer 14 via the host interface (not shown) with a 16-bit pixel value for each channel. Thus there are two numbers for each polygon, one indicating the red value and the second indicating the green value. When there are less than 32,768 polygon cells to sum, there will be some unused locations in SRAM 74-1, 74-2. The host computer will only read and clear the locations in SRAM 74-1, 74-2 corresponding to active cells being summed.

It may be the case that with a small audience (and proportionally larger cells) a cell can have sufficiently many pixels that there is a possibility that the sum of pixel values for that cell may overflow 16 bits. In this case, during calibration, the cell is split into one or more subcells of less than 256 pixels each. Then during the summing phase, the host computer adds the cell's partial sums after reading them from SRAM 74-1, 74-2.

Figure 9a shows the polygon summing circuit 60 ("summer") connected between camera 24 and computer 14, with computer 14 driving projector 30 via display card 26.

Where the room is divided up into sectors (see Figure 9b) several cameras 24-1, 24-2 (additional cameras not shown) are used to cover the auditorium, this sectorization being performed by the host computer 14-1 which then combines data from the various video cameras 24-1, 24-2 each of which has an associated summing circuit 60-1, 60-2 and associated intermediary smaller (less powerful) computer 14-2, 14-3, the computers 14-1, 14-2, 14-3 all being connected by a local area network. In this case there are multiple polygon summing circuits 60-1, 60-2, with one such circuit 60-1, 60-2 for each camera. The host computer 14-1 then determines which camera 24-1, 24-2 could best observe each seat, and assigns to each seat one camera 24-1, 24-2 so as to partition the audience amongst the cameras without overlap. The partitioning procedure for each point, i.e., cell, selects the camera 24-1, 24-2 which has the cell's projection point closest to the center of the camera image. For optimal signal-to-noise ratio in this sectorization process, it is best if there is a minimal brightness difference within an image between the brightest cell and dimmest cell which are in the sector assigned to each camera 24-1, 24-2. Thus the camera imaged area should be relatively uniform in distance

from the camera.

If the SRAM 74-1, 74-2 is sufficiently fast, the control component 82 can be modified to zero the appropriate bank at the beginning of a frame, thus relieving the host computer of the task. There will likely be background pixels not assigned to summing cells. The VRAM 78 locations corresponding to those pixels will contain a predetermined cell number, such as zero, whose sums are never cleared or read from SRAM 74-1 and 74-2 by the host computer.

One use of the thus obtained reflector state information (however processed) is to project on the screen 34 using video projector 30 an image viewable by the audience of the seating chart with the state of the reflector associated with each seat displayed in color. The audience members may then find themselves in the image by observing the image while manipulating their individual reflectors.

Another use may be to conduct surveys of the audience, asking them questions of fact and/or opinion and measuring their response. Another use may be to use the states as input to a multiplayer game, dividing the audience into sections, each section assuming the role of one "player" and acting as one by "voting". Another use may be to use the states as input to a music synthesizer, dividing the audience into sections, each section controlling one or more instrument parameters (pitch, volume, etc.).

Other embodiments employ methods of determining the state of an audience member's dot in the video camera image, in addition to its color, as described hereinafter.

In one such embodiment, the position of an audience member's dot is resolved relative to a neutral position, thus allowing one or more audience members individually, or in a group, to control a two dimensional input mode; this is similar to the way a mouse or tablet device controls a cursor in a computer system. Each audience member's input position is determined by subtracting the X and Y coordinates of the member's dot at rest from the dot's current X and Y coordinates. A perspective correction factor may be required to compensate for distance from the camera if there is a significant range of distance. The X and Y input values of some or all of the members (possibly so corrected) are aggregated by summing to produce X and Y coordinates for the audience as a group that represent the average displacement of the group's reflectors.

Each audience member's rest position can be determined by simply asking each member to hold his reflector in a comfortable position, while having the computer imaging system determine the individual dot locations; or alternatively by observing the range of movement during other use of the reflectors and finding the center of that range for each member.

The group cursor control as described immediately above allows an audience to interact with the display screen in much the same way as one does with a com-

puter system mouse. The audience can point to things on the screen, then change the color of their reflector, e.g. by rotating a stick, to select the button or icon under the cursor. Such two dimensional input mode also allows an audience to indicate direction on the screen to, for example, fly an airplane, indicate a target, or travel through a maze.

Since the number of screen pixels allocated to an individual audience member's seat is often small, usually less than 100, it is advantageous to compute the location of each dot to subpixel accuracy. This can be done by various means. One method, for example, is as follows: Find a pixel brighter than its four adjacent neighbors (left, right, up, down). In each direction, (horizontal, vertical) fit a parabola through the three intensity values, e.g., left, middle, right. Then find the subpixel coordinates of the peak of the horizontal and vertical parabolas. The formula is as follows:

Given P0, P1, P2 adjacent pixel intensity values, with pixel P1 brighter than both pixels P0 and P2. Pixel P1 may be the same brightness as pixels P0 or P2, but not both.

The subpixel coordinate is found by adding the following signed fraction to the coordinate of pixel P1:

$$\frac{P2 - P0}{2(2P1 - P0 - P2)}$$

Given the pixel location of the image of an audience member's reflector from one frame to the next, one determines the velocity (and direction) of the reflector by subtracting the dot's current XY location from its XY location in the previous frame. A second method is simultaneously for each audience member to locate the brightest pixel in the neighborhood of that member while summing the pixels in the neighborhood of that member. Neighborhoods are assigned as described above. If the magnitude of the brightest pixel is large relative to the sum, then the reflector is deduced to be stationary. On the other hand, if the brightest pixel ("bright") is significantly dimmer than the sum ("sum") of the pixels in the neighborhood, the image of the reflector must have been "smeared out" by movement. The formula for velocity v in this method is

$$v = \frac{\text{sum}}{\text{bright}} - 1$$

This method does not provide a direction indication. Also, the magnitude of the velocity may need to be adjusted for distance from the camera, as described above for cursor mode.

Velocity is useful as a measurement of an audience member's exertion in waving his reflector back and forth. The aggregated velocity for a group of audience members can be used to control, for example, the on-screen

speed of an animated figure such as a person or vehicle, thereby allowing part of an audience to race against another part.

In another embodiment, the state of an audience member's reflector or light is changed over time in a regular pattern to communicate information by signaling. For instance, an individual audience member could employ Morse Code or serial ASCII to send text information. For this means of communication, the computer system and camera monitor the state of each member's reflector or light at a fairly high rate, e.g. the video frame rate of 30 frames per second. The state of each reflector or light is treated independently as if they were many parallel sampled serial communication lines. Any one of various well known algorithms are used to extract information from the streams of samples; for example, the algorithm used in a UART, a computer serial communications chip. This technique allows audience members to employ 'smart' light sources that each send, for example, a unique serial number which distinguishes players in a game. The serial number is then used to verify the identity of the winner after the game is completed.

Many variations are available in accordance with the invention. The above described first embodiment is essentially communicating tri-state data: a red reflection, a green reflection, or none (no response). Instead, there may be only two states: reflection or none, or multi-state (additional colors). Instead of colors, the states of the reflectors may be distinguished by being of different polarizations. The reflecting devices may be fluorescent in one or more colors, thus eliminating the need for a visible light source. Instead of visible light, the illumination could be infra-red or other wavelengths, with a corresponding change in the nature of the reflectors. Also, instead of reflectors, each 5 participant could be provided with a self powered light source such as a flashlight.

Also, the scanning may be performed (alternatively to the camera 24 and light of Figure 2A) by one or more movable (oscillating) mirrors instead of a video camera. In this case, the system includes a laser 90, a mirror light beam deflecting apparatus 92, and a photodetector 94. Also included in one embodiment are conventional beam splitter 96 and beam stop 98.

This disclosure includes copyrighted material; permission is given for facsimile reproduction of material in Patent Office files, but all other copyright rights are reserved.

The above description is illustrative and not limiting; further modifications will be apparent to one of ordinary skill in the art in light of this disclosure and the appended claims.

Claims

1. A method for collecting data from a plurality of persons (36-1, 36-2) simultaneously present in a room, comprising the steps of:

providing each one of the plurality of persons with a radiation source (44) capable of defining at least two states, at least one of which is detectable by a detector (24);

scanning at least a part of the room with said detector (24) thereby detecting the radiation sources (44) which are in a detectable state;

determining the states of the detected radiation sources (44); and

aggregating the determined states into data.

2. The method of Claim 1, wherein the step of scanning comprises using a video camera (24).

3. The method of Claim 1, wherein the step of scanning comprises collecting light with a movable mirror (92).

4. The method of Claim 1, wherein each radiation source (44) is a retroreflector for reflecting incident light.

5. The method of Claim 4, further comprising the step of providing a source (40) of incident light mounted substantially coaxially with the detector (24) to illuminate the retroreflectors (44).

6. The method of Claim 4, wherein each retroreflector (44) reflects at least two distinguishable colors, each color defining one state of the radiation source.

7. The method of Claim 4, wherein the incident light is polarized, and each radiation source (44) is a polarized reflector defining at least two states of the radiation source by different rotations of the plane of polarization of reflected incident polarized light.

8. The method of Claim 4, wherein the incident light is unpolarized and each radiation source (44) is a polarized reflector defining at least two states of the radiation source by different orientations of the plane of polarization of reflected incident unpolarized light.

9. The method of Claim 1, wherein each radiation source (44) is fluorescent in at least one color.

10. The method of Claim 1, wherein the radiation is infrared.

11. The method of Claim 1, wherein the states are defined by movement of each radiation source (44).

12. The method of Claim 11, wherein the states are de-

finied by a velocity of the movement.

13. The method of Claim 1, wherein the radiation sources (44) are each identified by coded information transmitted by the radiation source (44).

14. The method of Claim 1, further comprising the steps of: providing a plurality of detectors (24-1, 24-2), each detector scanning a predetermined portion of the room; dividing each predetermined portion into a plurality of cells (56-1, 56-2), each cell including only one of the radiation sources (50-1, 50-2); and summing an intensity value of the radiation source in each cell, over all the cells.

15. A system for collecting data from a plurality of persons (36-1, 36-2) simultaneously present in a room, each one of the plurality of persons being provided with a radiation source (44) capable of defining at least two states, at least one of which is detectable by a detector (24), comprising:

said detector (24) for scanning at least a part of the room thereby detecting the radiation sources (44) which are in a detectable state;

means (14) for determining the states of the detected radiation sources (44); and

means (14) for aggregating the determined states into data.

16. The system of Claim 15, wherein each radiation source (44) comprises a retroreflector which reflects at least two distinguishable colors, each color defining at least one state, and wherein the detector comprises a video camera (24), and further comprising:

a source (40) of light mounted substantially coaxially with the video camera (24);

means (14) for defining a plurality of cells (56-1, 56-2)

scanned by the video camera (24), each cell including only one of the radiation sources (50-1, 50-2); and

means (14) for summing an intensity value of the radiation source in each cell, over all the cells.

17. The system of Claim 16, wherein the means (14) for summing includes:

two video channels (video 1, video 2), each for receiving a video signal associated with one of the states of the radiation sources (50-1, 50-2); an analog to digital converter (64-1, 64-2) to digitize the received video signal for each chan-

nel;

a look-up table (66-1, 66-2) for correcting the digitized video signal for each channel;

a latch (68-1, 68-2) for storing the corrected digitized video signal for each channel;

a first memory (74-1, 74-2) for storing the latched signal for each channel; and

a second memory (78) for storing a pixel address associated with the latched signal.

18. The system of Claim 16, wherein the detector (24) includes:

means (14) for detecting movement of each scanned radiation source; and means (14) for determining a location of each scanned radiation source to subpixel accuracy by finding a pixel brighter than adjacent pixels on a video image of the scanned radiation source.

Patentansprüche

1. Verfahren zum Sammeln von Daten von einer Vielzahl von Personen (36-1, 36-2), welche gleichzeitig in einem Raum anwesend sind, mit den folgenden Schritten:

Versehen jeder Person aus der Vielzahl von Personen mit einer Strahlungsquelle (44), welche in der Lage ist, mindestens zwei Zustände anzunehmen, von denen wenigstens einer durch einen Detektor (24) erfaßbar ist;

Abtasten wenigstens eines Teiles des Raumes mit dem Detektor (24), wodurch die Strahlungsquellen (44), die sich in einem erfaßbaren Zustand befinden, erfaßt werden;

Bestimmen der Zustände der erfaßten Strahlungsquellen (44); und

Ansammeln der bestimmten Zustände als Daten.

2. Verfahren nach Anspruch 1, bei dem der Abtastschritt die Verwendung einer Videokamera (24) umfaßt.

3. Verfahren nach Anspruch 1, bei dem der Abtastschritt das Sammeln von Licht mit einem beweglichen Spiegel (92) umfaßt.

4. Verfahren nach Anspruch 1, bei dem jede Strahlungsquelle (44) ein Retro-Reflektor zur Reflexion von einfallendem Licht ist.

5. Verfahren nach Anspruch 4, welches ferner den Schritt aufweist, eine Quelle (40) für einfallendes Licht vorzusehen, die im wesentlichen coaxial zu dem Detektor (24) zur Beleuchtung der Retro-Reflektoren (44) angebracht ist.

6. Verfahren nach Anspruch 4, bei dem jeder Retro-Reflektor (44) wenigstens zwei unterscheidbare Farben reflektiert, wobei jede Farbe einen Zustand der Strahlungsquelle definiert.
7. Verfahren nach Anspruch 4, bei dem das einfallende Licht polarisiert ist und jede Strahlungsquelle (44) ein polarisierter Reflektor ist, welcher wenigstens zwei Zustände der Strahlungsquelle durch unterschiedliche Drehungen der Polarisationsebene des reflektierten einfallenden polarisierten Lichtes definiert.
8. Verfahren nach Anspruch 4, bei dem das einfallende Licht unpolarisiert ist und jede Strahlungsquelle (44) ein polarisierter Reflektor ist, welcher wenigstens zwei Zustände der Strahlungsquelle durch unterschiedliche Orientierungen der Polarisationsebene des reflektierten einfallenden unpolarisierten Lichtes definiert.
9. Verfahren nach Anspruch 1, bei dem jede Strahlungsquelle (44) wenigstens in einer Farbe fluoreszierend ist.
10. Verfahren nach Anspruch 1, bei dem die Strahlung Infrarot ist.
11. Verfahren nach Anspruch 1, bei dem die Zustände durch die Bewegung jeder Strahlungsquelle (44) definiert werden.
12. Verfahren nach Anspruch 11, bei dem die Zustände durch die Geschwindigkeit der Bewegung definiert werden.
13. Verfahren nach Anspruch 1, bei dem die Strahlungsquellen (44) jeweils durch codierte Information identifiziert werden, die durch die Strahlungsquelle (44) übertragen wird.
14. Verfahren nach Anspruch 1, welches ferner die folgenden Schritte aufweist:
- Vorsehen einer Vielzahl von Detektoren (24-1, 24-2), wobei jeder Detektor einen vorbestimmten Abschnitt des Raumes abtastet;
Teilen eines jeden vorbestimmten Abschnittes in eine Vielzahl von Zellen (56-1, 56-2), wobei jede Zelle lediglich eine der Strahlungsquellen (50-1, 50-2) enthält; und Summieren eines Intensitätswertes der Strahlungsquelle in jeder Zelle, über alle Zellen hinweg.
15. System zur Datensammlung von einer Vielzahl von Personen (36-1, 36-2), welche gleichzeitig in einem Raum anwesend sind, wobei jede Person aus der Vielzahl von Personen mit einer Strahlungsquelle (44) versehen ist, die in der Lage ist, wenigstens zwei Zustände zu definieren, wobei jeder von diesen durch einen Detektor (24) erfaßbar ist, mit: dem Detektor (24) zum Abtasten wenigstens eines Teiles des Raumes, wodurch die Strahlungsquellen (44), die sich in einem erfaßbaren Zustand befinden, erfaßbar sind; einer Einrichtung (14) zur Bestimmung der Zustände der erfaßten Strahlungsquellen (44); und mit einer Einrichtung (14) zur Ansammlung der vorbestimmten Zustände als Daten.
16. System nach Anspruch 15, bei dem jede Strahlungsquelle (44) einen Retro-Reflektor aufweist, welcher wenigstens zwei unterscheidbare Farben reflektiert, wobei jede Farbe wenigstens einen Zustand definiert, und wobei der Detektor eine Videokamera (24) aufweist, und welche ferner aufweist:
- eine Lichtquelle (40), die im wesentlichen koaxial zu der Video-Kamera (24) montiert ist;
eine Einrichtung (14) zur Festlegung einer Vielzahl von Zellen (56-1, 56-2), die durch die Videokamera (24) abtastbar sind, wobei jede Zelle lediglich eine der Strahlungsquellen (50-1, 50-2) enthält; und
eine Einrichtung (14) zur Aufsummierung eines Intensitätswertes der Strahlungsquelle in jeder Zelle, über alle Zellen hinweg.
17. System nach Anspruch 16, bei dem die Einrichtung (14) zur Aufsummierung enthält:
- zwei Videokanäle (Video 1, Video 2), wobei jeder zum Empfang eines Videosignals vorgesehen ist, das zu einem der Zustände der Strahlungsquellen (50-1, 50-2) gehört;
einen Analog-Digitalwandler (64-1, 64-2) zur Digitalisierung des empfangenen Videosignals für jeden Kanal;
eine Verweistableneinrichtung (66-1, 66-2) zum Korrigieren des digitalisierten Videosignals für jeden Kanal;
einen Signalspeicher (68-1, 68-2) zum Speichern des korrigierten digitalisierten Videosignals für jeden Kanal;
einen ersten Speicher (74-1, 74-2) zum Abspeichern des im Signalspeicher gespeicherten Signals für jeden Kanal; und
einen zweiten Speicher (78) zum Abspeichern einer Pixel-Adresse, die zu dem im Signalspeicher abgespeicherten Signal gehört.
18. System nach Anspruch 16, bei dem der Detektor (24) enthält:
- eine Einrichtung (14) zur Erfassung der Bewegung einer jeden abgetasteten Radioquelle; und eine Einrichtung (14) zur Bestimmung ei-

ner örtlichen Lage einer jeden abgetasteten Strahlungsquelle bis zu einer unter einem Pixel liegenden Genauigkeit, indem man einen Pixel findet, welcher heller ist als die benachbarten Pixel auf einem Videobild der abgetasteten Strahlungsquelle.

Revendications

1. Procédé pour la collecte de données provenant d'une pluralité de personnes (36-1,36-2) simultanément présentes dans une salle, comprenant les étapes de :
 - fourniture, à chaque personne de la pluralité de personnes, d'une source de rayonnement (44) pouvant définir au moins deux états, dont l'un au moins est détectable par un détecteur (24) ; balayage d'au moins une partie de la salle avec ledit détecteur (24) de façon à détecter les sources de rayonnement (44) qui sont dans un état détectable ;
 - détermination des états des sources de rayonnement détectées (44) ; et
 - agrégation des états déterminés en données.
2. Procédé suivant la revendication 1, dans lequel l'étape de balayage comprend l'utilisation d'une caméra vidéo (24).
3. Procédé suivant la revendication 1, dans lequel l'étape de balayage comprend la collecte de lumière au moyen d'un miroir mobile (92).
4. Procédé suivant la revendication 1, dans lequel chaque source de rayonnement (44) est un rétro-réflécteur pour réfléchir une lumière incidente.
5. Procédé suivant la revendication 4, comprenant en outre l'étape de création d'une source (40) de lumière incidente montée sensiblement coaxialement avec le détecteur (24) pour éclairer les rétro-réflécteurs (44).
6. Procédé suivant la revendication 4, dans lequel chaque rétro-réflécteur (44) réfléchit au moins deux couleurs différenciables, chaque couleur définissant un état de la source de rayonnement.
7. Procédé suivant la revendication 4, dans lequel la lumière incidente est polarisée, et chaque source de rayonnement (44) est un réflecteur polarisé définissant au moins deux états de la source de rayonnement par des rotations différentes du plan de polarisation de la lumière polarisée incidente réfléchie.
8. Procédé suivant la revendication 4, dans lequel la lumière incidente est non polarisée et chaque source de rayonnement (44) est un réflecteur polarisé définissant au moins deux états de la source de rayonnement par des orientations différentes du plan de polarisation de la lumière non polarisée incidente réfléchie.
9. Procédé suivant la revendication 1, dans lequel chaque source de rayonnement (44) est fluorescente dans au moins une couleur.
10. Procédé suivant la revendication 1, dans lequel le rayonnement est infrarouge.
11. Procédé suivant la revendication 1, dans lequel les états sont définis par un mouvement de chaque source de rayonnement (44).
12. Procédé suivant la revendication 11, dans lequel les états sont définis par une vitesse du mouvement.
13. Procédé suivant la revendication 1, dans lequel les sources de rayonnement (44) sont identifiées chacune par une information codée transmise par la source de rayonnement (44).
14. Procédé suivant la revendication 1, comprenant en outre les étapes de :
 - utilisation d'une pluralité de détecteurs (24-1, 24-2), chaque détecteur balayant une portion prédéterminée de la salle ;
 - division de chaque portion prédéterminée en une pluralité de cellules (56-1,56-2), chaque cellule contenant seulement une des sources de rayonnement (50-1,50-2); et
 - addition d'une valeur d'intensité de la source de rayonnement de chaque cellule, pour la totalité des cellules.
15. Appareil de collecte de données provenant d'une pluralité de personnes (36-1,36-2) simultanément présentes dans une salle, chaque personne de la pluralité de personnes étant pourvue d'une source de rayonnement (44) qui peut définir au moins deux états dont l'un au moins est détectable par un détecteur (24), comprenant :
 - ledit détecteur (24) pour balayer au moins une partie de la salle de façon à détecter les sources de rayonnement (44) qui sont dans un état détectable ;
 - des moyens (14) de détermination des états des sources de rayonnement détectées (44) ; et
 - des moyens (14) d'agrégation des états déterminés, en données.

16. Appareil suivant la revendication 15, dans lequel chaque source de rayonnement (44) comprend un rétroreflécteur qui réfléchit au moins deux couleurs différenciables, chaque couleur définissant au moins un état, et dans lequel le détecteur comprend une caméra vidéo (24), et comprenant en outre :

une source (40) de lumière, montée sensiblement coaxialement avec la caméra vidéo (24) ;
des moyens (14) de définition d'une pluralité de cellules (56-1,56-2) balayées par la caméra vidéo (24), chaque cellule contenant seulement une des sources de rayonnement (50-1,50-2) ;
et
des moyens (14) d'addition d'une valeur d'intensité de la source de rayonnement de chaque cellule, pour la totalité des cellules.

17. Appareil suivant la revendication 16, dans lequel les moyens d'addition (14) comprennent :

deux canaux vidéo (vidéo 1, vidéo 2), chacun pour recevoir un signal vidéo associé à un des états des sources de rayonnement (50-1,50-2) ;
un convertisseur analogique-numérique (64-1, 64-2) pour numériser le signal vidéo reçu pour chaque canal ;
une table de consultation (66-1,66-2) pour corriger le signal vidéo numérisé pour chaque canal ;
une bascule (68-1,68-2) pour stocker le signal vidéo numérisé pour chaque canal ;
une première mémoire (74-1,74-2) pour stocker le signal accroché pour chaque canal ; et
une deuxième mémoire (78) pour stocker une adresse de pixel associée au signal accroché.

18. Appareil suivant la revendication 16, dans lequel le détecteur (24) comprend :

des moyens (14) de détection du mouvement de chaque source de rayonnement balayée ; et
des moyens (14) de détermination d'une position de chaque source de rayonnement balayée, avec une précision inférieure au pixel, par recherche d'un pixel plus brillant que les pixels adjacents sur une image vidéo de la source de rayonnement balayée.

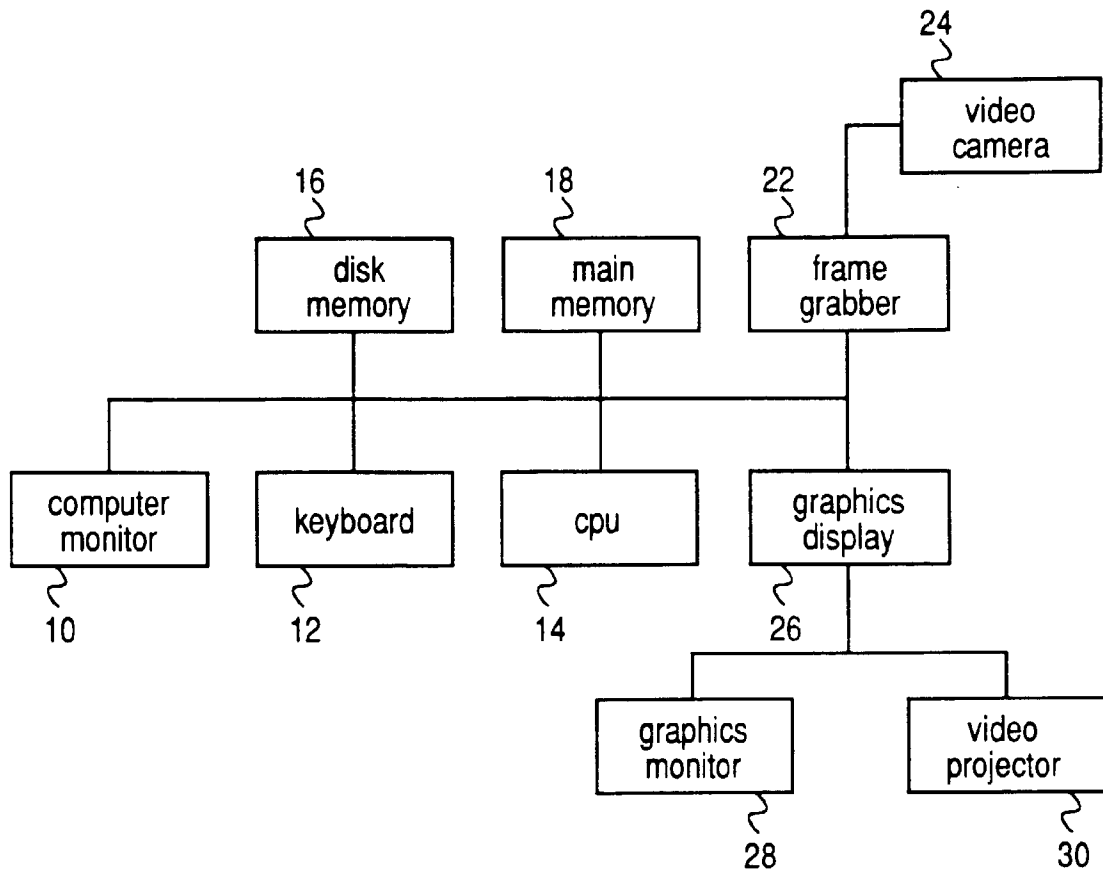

FIG. 1

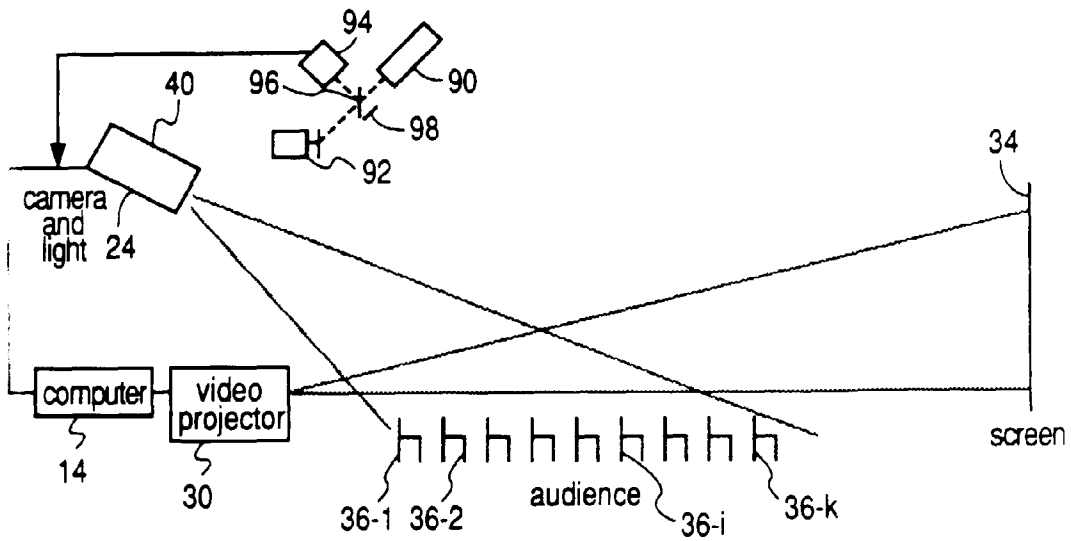

FIG. 2a

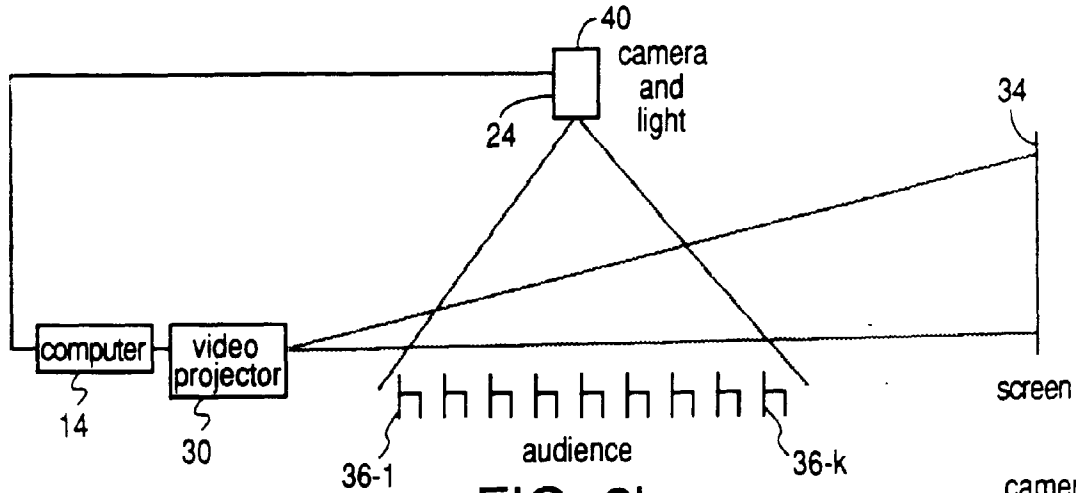

FIG. 2b

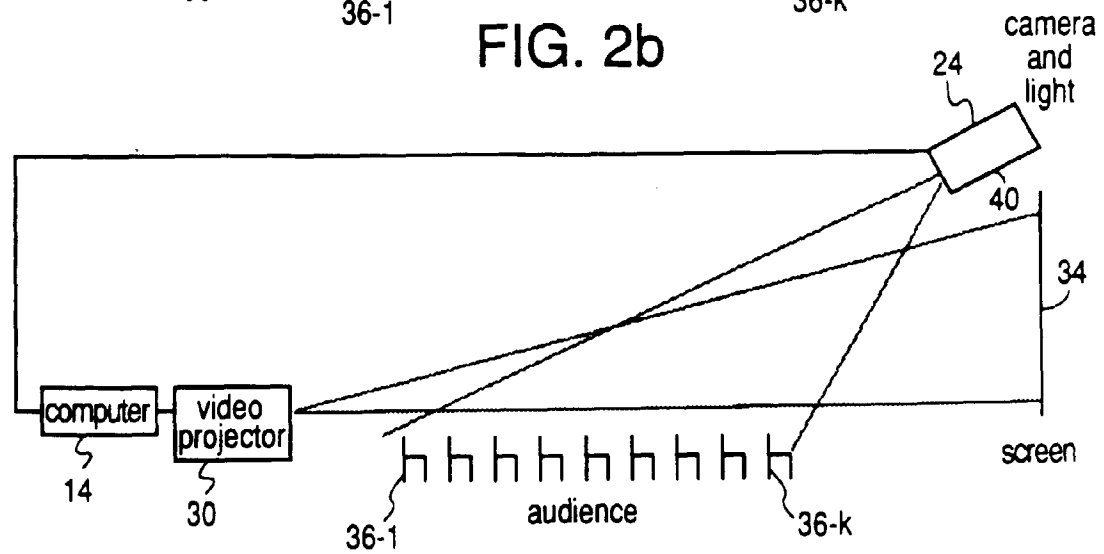

FIG. 2c

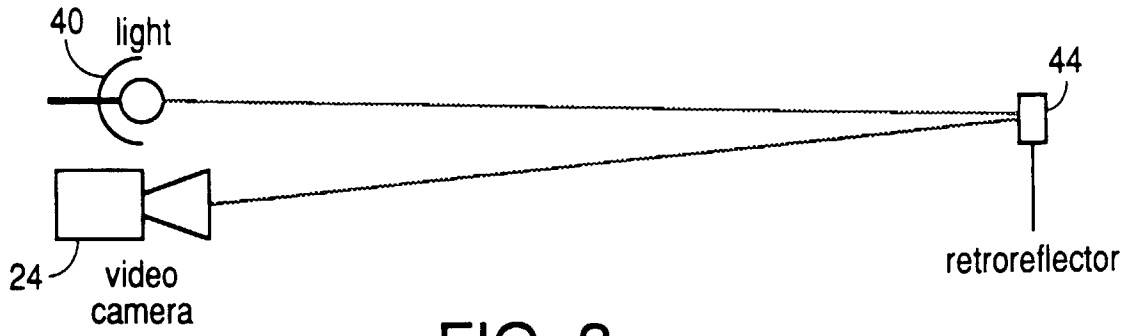

FIG. 3

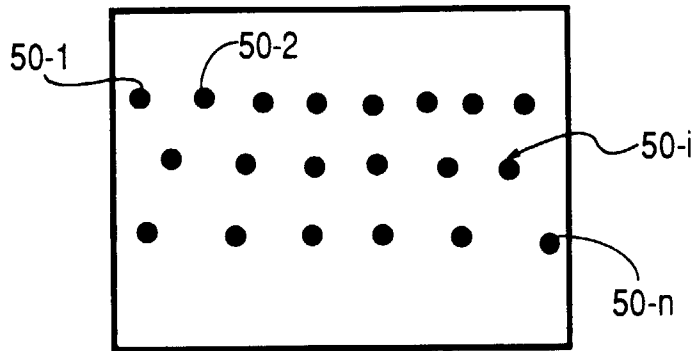

FIG. 4

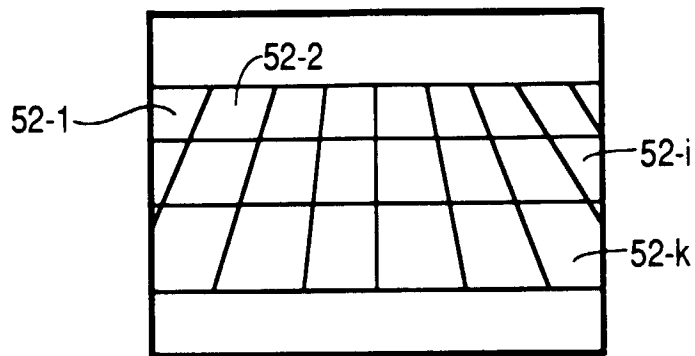

FIG. 5

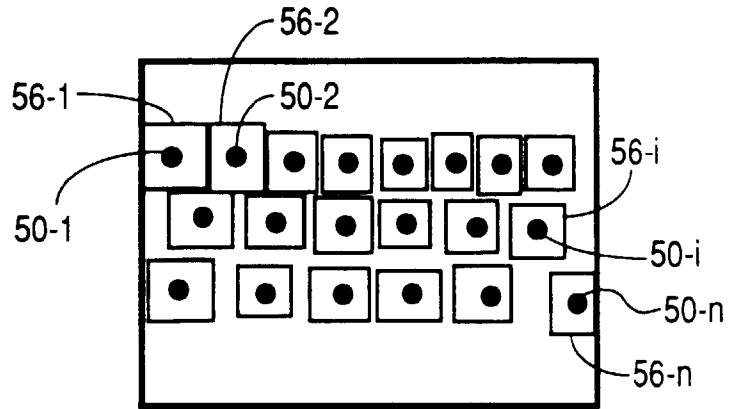

FIG. 6

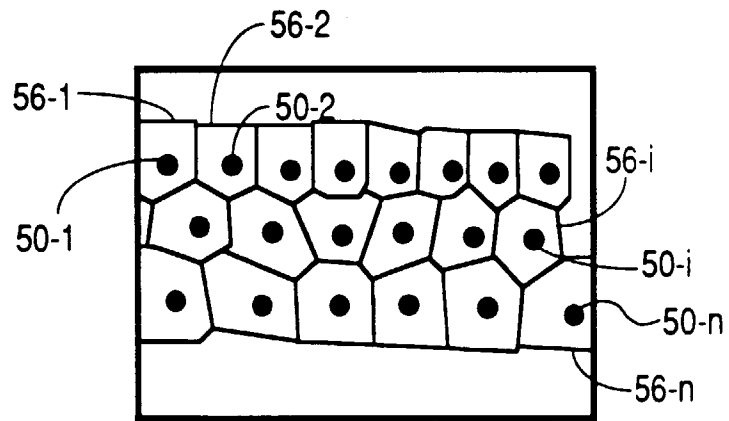

FIG. 7

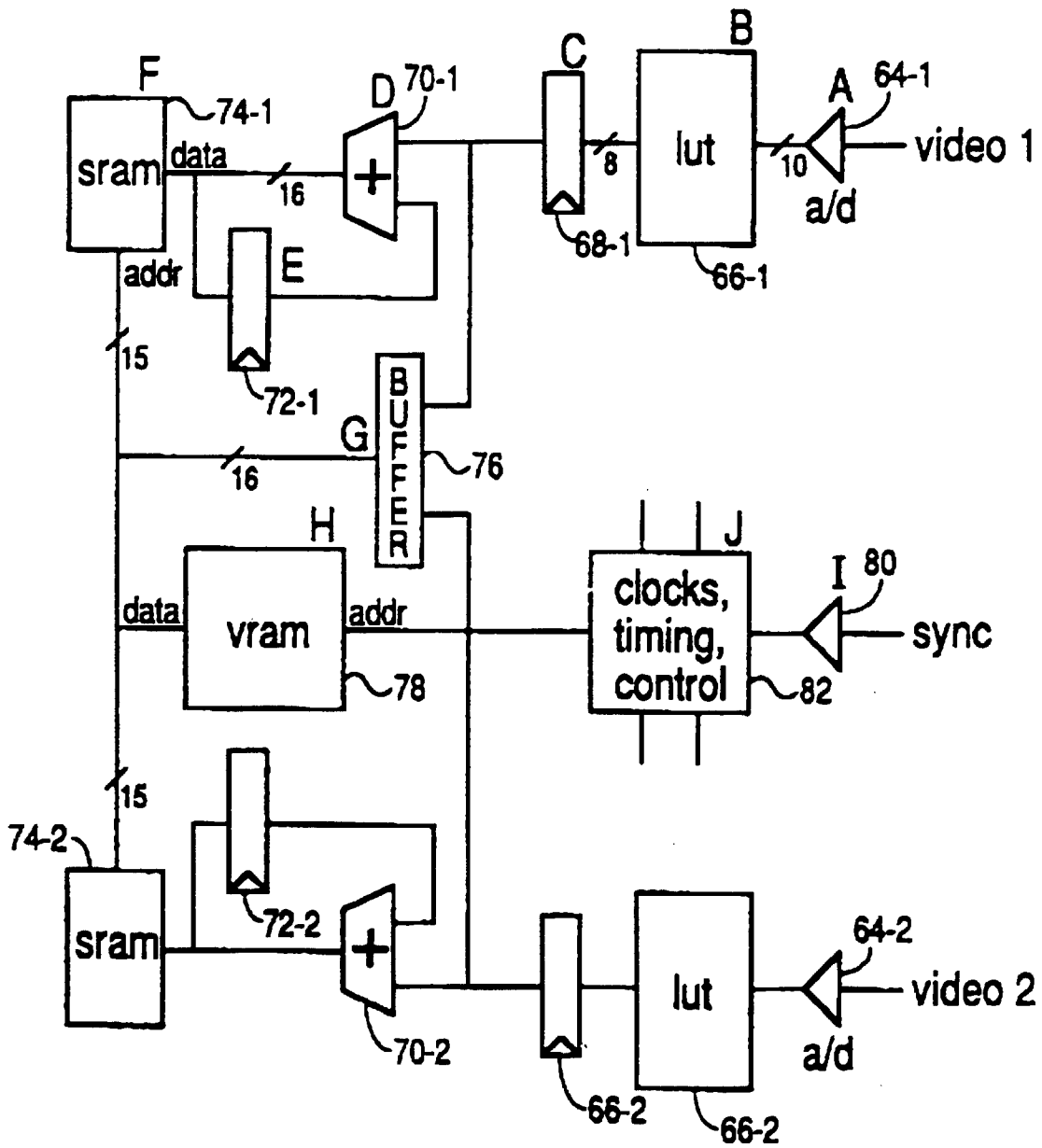

FIG. 8

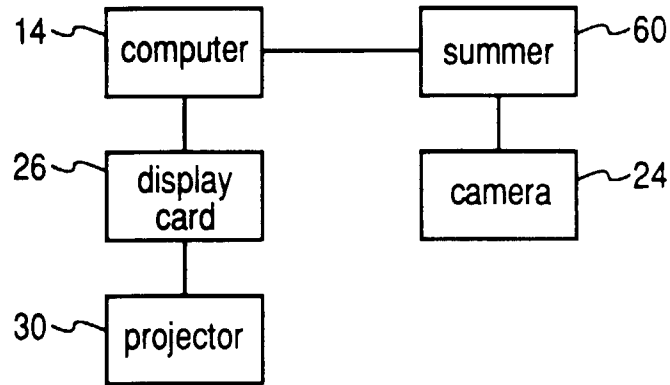

FIG. 9a

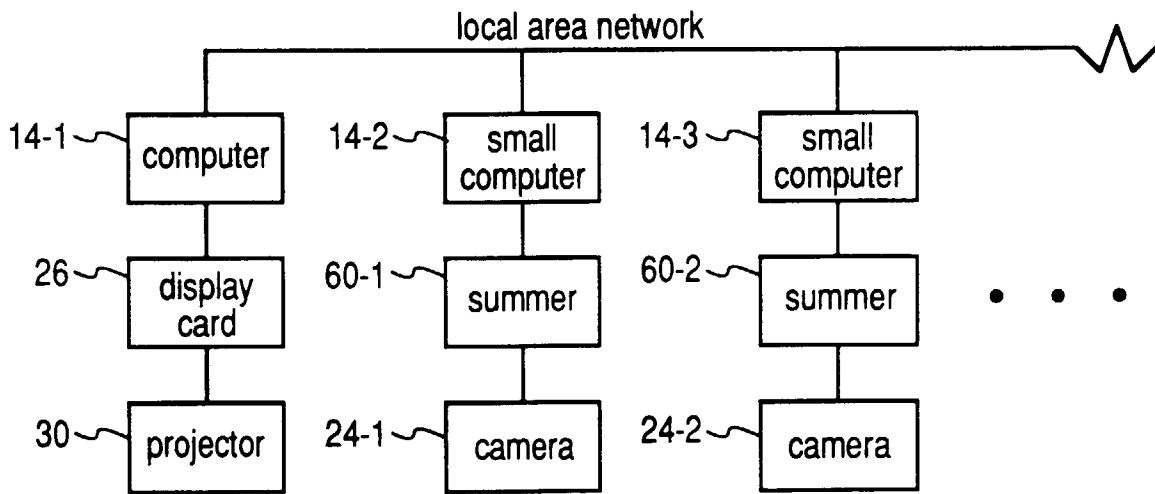

FIG. 9b