

(19)



Europäisches Patentamt

European Patent Office

Office européen des brevets



(11)

EP 0 639 095 B1

(12)

EUROPEAN PATENT SPECIFICATION

(45) Date of publication and mention of the grant of the patent:

03.09.1997 Bulletin 1997/36

(21) Application number: **93911675.2**

(22) Date of filing: **03.05.1993**

(51) Int. Cl.⁶: **A63H 33/08**, A63H 33/06

(86) International application number:
PCT/AU93/00189

(87) International publication number:
WO 93/22018 (11.11.1993 Gazette 1993/27)

(54) **TOY BUILDING ELEMENT**

SPIELZEUGBAUELEMENT

ELEMENT DE JEU DE CONSTRUCTION

(84) Designated Contracting States:
**AT BE CH DE DK ES FR GB GR IE IT LI LU MC NL
PT SE**

(30) Priority: **07.05.1992 AU 2289/92**

(43) Date of publication of application:
22.02.1995 Bulletin 1995/08

(73) Proprietor:
**BETTER BLOCKS INTERNATIONAL LIMITED
Auckland (NZ)**

(72) Inventor: **WILSON, Warren, Scott
Lockleys, S.A. 5023 (AU)**

(74) Representative: **Denmark, James
Bailey, Walsh & Co.
5 York Place
Leeds LS1 2SD Yorkshire (GB)**

(56) References cited:
**AU-A- 1 232 976 DE-A- 2 446 475
GB-A- 506 204 US-A- 2 649 803**

EP 0 639 095 B1

Note: Within nine months from the publication of the mention of the grant of the European patent, any person may give notice to the European Patent Office of opposition to the European patent granted. Notice of opposition shall be filed in a written reasoned statement. It shall not be deemed to have been filed until the opposition fee has been paid. (Art. 99(1) European Patent Convention).

Description

This invention relates to a toy building element which incorporates a block having semi-circular curved ends and releasable engagement means which allows other like blocks relative rotation about an axis of the engagement means.

The prior art of toy building elements, and in particular blocks, has many examples of block design which include substantially rectangular blocks with protrusions of cylindrical and other shapes that engage with an interference fit, into complementary cavities, located in the bases of similar blocks. This configuration allows blocks to be placed together in various combinations dependent upon the configuration of the protrusions and cavities used.

A well known example is a product produced by the company Interlego A.G. and sold under the Registered Trade Mark "Lego". In one of its most basic aspects, a block has parallel sides, parallel top and bottom surfaces, cylindrically shaped protuberances projecting from its top surface and cavities for location of similar protuberances in its underside. Each of the blocks has identical configuration of protuberances and cavities and the blocks are capable of being interconnected, bottom to top or vice versa, the protuberances and internal cavities, when the blocks are thus interconnected, releasably engaging one another.

The blocks can be disengaged and one or both of the blocks can be rotated about an axis which is normal to the top and bottom of the block and the block can then be re-engaged. This manipulation is possible as a direct result of the configuration of the protuberances and cavities thereon.

The Interlego A.G. range of toy building elements is shaped and configured in a multiplicity of ways but the common engagement means is by interference fit of a cylindrical protuberance into a complementary cavity.

Other toy building elements exist that utilise ridges and reciprocal cavities on the top, bottom and also sides of the block as evidenced by examples in U.S. 3905150, DE 1603304 and AU 86/51923.

The prior art of toy building blocks that require interference fit engagement means rely on the frictional strength and stability of the coupled blocks. This has the disadvantage of reliance on a single protuberance and cavity in some cases. In other configurations of the construction of items with the abovementioned blocks, there is no rotation of the interconnected blocks, one with respect to the other, lest the interference fit twists itself out of frictional engagement.

It is an object of this invention to overcome at least some of the above shortcomings.

In its broadest aspect, the present invention provides a toy building block having a protuberance on an outer surface thereof, the protuberance having a ridge which engages a complementary groove in a cavity in another block by resilient deformation, thereby enabling relative rotation and releasable retention.

A further problem of the prior art is that curved structures cannot be constructed with the standard block and this need is met by the supply of fixed curvature blocks.

Therefore it is an object of this invention to provide a toy building element to enable the construction of curved structures.

A still further object of this invention is to provide a block that is simple to manufacture and simple to use.

More specifically according to this invention, a toy building element comprises at least one protuberance projecting from an upper surface thereof and at least one downwardly opening cavity on the underside of the element, the or each protuberance having a circumferential ridge, and the or each cavity having an internal circumferential groove, such that, when two like elements are to be joined together the or each protuberance is press-fitted within a respective said cavity with the ridge engaging within an associated said groove to thereby interlock the elements together, with the elements being able to swivel relative to one another about an axis common to both the cavity and the protuberance received therein.

Preferably, each building element has a pair of protuberances and a pair of complementary cavities on opposite faces thereof, for interlocking with similar elements.

Preferably, each element is a hollow block having an open bottom and a closed top wall, the top wall having a generally planar upper surface, two opposed parallel sides and two opposed end walls depending from the periphery of the top wall, wherein the end walls are convexly curved with each protuberance being disposed at approximately the centre of curvature of a respective said curved end wall adjacent thereto.

Preferably, the block elements are injection moulded of resilient plastics material, e.g. polyethylene or polypropylene.

In order to allow the block elements to be used in conjunction with existing toy building elements of a similar type, adapter blocks can be provided, each of which has on one of its major faces a configuration of either bosses or cavities which are interlockable with the cavities or bosses respectively on existing building elements, its other major face having a configuration of either protuberances or cavities according to the present invention.

In order that the invention may be more clearly understood and readily carried into effect, several embodiments thereof will now be described by way of example only, with reference to the accompanying representations, wherein:-

Fig. 1 shows a top perspective view of a toy building element according to a first embodiment of the invention;

Fig. 2 is a perspective view showing the bottom of a toy building element of Fig. 1;

Figs. 3 (a), (b) and (c) show top, bottom and side elevational views of the building element of Fig. 1;

Fig. 4 is an elevational view, partly sectioned, showing a construction example wherein several building elements are interlocked;

Fig. 5 is a plan view of the interlocked elements shown in Fig. 4, with the dotted lines showing the positions of rotation of one of the elements;

Figs. 6 (a) and (b) are perspective views of a building block according to a second embodiment of the invention;

Figs. 7 (a) and (b) are perspective views of an adapter building block according to another embodiment;

Figs. 8 (a) and (b) are perspective views of another block according to a further embodiment of the invention; and

Figs. 9 (a) and (b) are perspective views of another adapter block for connection to other makes of building block elements of a similar kind.

Referring to Figs. 1 to 3, there is shown an approximately oval shaped toy building block 10 having a closed planar top end 11, an open bottom end 12, parallel side walls 13 and semi-circular end walls 14. The upper surface of top end 11 has projecting upwardly therefrom, a pair of spaced apart circular hollow bosses or protuberances 15 each having a cylindrical side wall 16 and a flat closed end wall 17. Each of the side walls 16 has a circumferential rib or ridge 18 extending therearound, the ridges 18 being designed to lockingly engage in shallow circular grooves 20, formed on the inside of cylindrical cavities 21, as shown in Fig. 2, of another block 10. The cavities 21 extend inwardly from the open bottom end 12 of the block 10 and are defined by cylindrical walls 22 which are co-axial with corresponding protuberances 15. The diameter of the cavities 21 is marginally greater than the diameter of the protuberances 15.

Referring to Figs. 4 and 5 of the drawings, several identical blocks 10, 10' are snap-fittingly engaged by pressing same together in the direction indicated by arrows 23 to form two horizontal layers, with a protuberance 15 on block 10 engaging within a cavity 21' on block 10' and its associated ridge 18 engaging within the groove 20' of cavity 21'. When thus engaged, the blocks 10, 10' can be rotated relative to one another about axis a-a as shown on Fig. 4, which shows the top block 10' being rotatable with respect to the fixed position of the bottom block 10.

Disengagement of the blocks is achieved by reversing the engagement process described above. An audible "click" is evident with each engagement and

disengagement procedure. The disengagement of the blocks can be done by means of a suitable tool (or block) having a lug which can be inserted between the engaged blocks through slots 25 formed in the end walls 14 thereof in order to lever the blocks apart.

In order to permit laterally adjacent blocks 10 of an horizontal row of blocks to be rotated or swivelled relative to one another, to thereby form curved structures, e.g. loops, without the end walls 14 thereof interfering with one another, the end walls 14 are convexly curved, in this instance semi-circular, with the protuberances 15 located respectively at the centre of curvature of the curved ends 14, adjacent thereto.

As shown in Fig. 4, the blocks 10 can be interlocked in horizontal layers in which each block in one layer is staggered with respect to the blocks in the adjacent layer, with each block being connected to an horizontally adjacent block through the block(s) immediately vertically adjacent.

Referring to Fig. 6 of the drawings, a building block 30 according to a second embodiment of the invention, is circular in plan and comprises a smooth cylindrical wall 31 which extends between the closed top end and open bottom end of the block, the top end having a cylindrical protuberance 32 centrally disposed thereon, whilst the bottom end has extending inwardly therefrom a central cavity 33 defined by cylindrical wall 34. As with the block of the first embodiment, the protuberance or boss 32 has a circumferential rib 35, whilst the wall 34 is provided with an internal groove 36 in which a rib on a protuberance of another block (whether the same or different) can be lockingly engaged when the blocks are press fitted together. The block 30 allows different block construction assemblies to be interconnected, e.g. joining a ring structure to a layered structure.

Referring to Figs. 7 and 9 of the drawings, there are shown two different connector blocks 40, 50 which can be used in order to join together building blocks 10, 30 of the present invention and building blocks of different makes e.g. Lego (Registered Trade Mark). Block 40 has an upper body portion which is identical to that of block 10, whilst its underside is provided with a plurality of cavities 41 which are configured so that the block 40 can be connected to an existing "Lego" block through frictional contact between the cavity walls 42 and the bosses on the top face of the other block. The upper planar face 43 of block 40 has two protuberances 44 each having ridges 45 to enable the block to connect to blocks 10, 30 of the present invention.

Block 50 has a lower body portion identical to that of block 10, whilst its upper face is provided with a series of bosses 52 which are configured so that the block 50 can connect to the bottom of an existing "Lego" block. The underside of block 50 has two cavities 53, each having circumferential grooves 54 to enable same to connect to the blocks 10, 30 of the present invention (or to block 40).

Referring to Figs. 8 (a) and (b), there is shown a block 60 which in many respects is identical to block 30

(Fig. 6), but in addition is provided with a pair of diametrically opposite protuberances 61 and a pair of diametrically opposite cavities 62 spaced around the cylindrical wall 63 of the block 60. This permits the block 60 to be joined to blocks 10 with the latter having been rotated through 90°. As with block 10, the top face of block 60 has a central protuberance 65 with a ridge 66 extending therearound, and the open bottom end has a central cylindrical cavity 67 with groove 68, extending inwardly therefrom.

It would be evident to the skilled addressee that various other configurations of the invention applied to toy building elements are possible. In one example, the building element could have a cross shape which maintains the flexibility of rotational displacement, upon engagement, of additional blocks.

Additionally, it will be evident that the ridge located on the cylindrical protrusion of the embodiments shown could be substituted with a series of knobs, spherical protrusions or like shapes complementary to the annular groove which define a circumferential ridge, such as to allow rotational movement of the building elements upon engagement.

It will be evident that the toy blocks of the preset invention provide far greater versatility in constructing building structures than can be achieved with prior art toy building elements, in that they enable the construction of curved structures, are simple to use and can be manufactured at low cost.

Claims

1. A toy building element comprising a hollow block (10) having a closed upper end (11), an open lower end (12), and a peripheral side wall (13,14) interconnecting the upper and lower ends, at least one protuberance (15) projecting from said upper end at least one downwardly opening cavity (21) extending inwardly from the open lower end of the block, the or each protuberance having a circumferential ridge (18), and the or each cavity having an internal circumferential groove (20), the blocks being dimensioned and shaped such that, when two like elements are joined together, the or each protuberance (15) is press fitted within a respective said cavity (21) with the ridge (18) engaging within an associated said groove (20) to thereby interlock the elements together, with the elements being rotatable relative to one another about an axis common to both the cavity (21) and the protuberance (15) engaged therein.
2. A toy building element according to claim 1 wherein said block is approximately oval shaped and has two said protuberances and two said cavities, wherein the peripheral side wall includes a pair of opposed parallel side wall portions and a pair of opposite end wall portions, wherein said end wall portions are convexly curved, with each said protu-

berance being disposed at approximately the centre of curvature of a respective said curved end wall portion adjacent thereto.

3. A toy building element according to claim 2 wherein each said end wall portion is provided with a recess or slot extending inwardly from its lower end for engagement by a release tool for assisting the separation of the blocks when joined together.
4. A toy building element according to claim 1 wherein the block is circular in plan and is provided with a single protuberance centrally located on the upper end of the block, and a single said cavity centrally located and extending inwardly of the open bottom end of the block and being coaxially aligned with said single protuberance.
5. A toy building element according to claim 4 further comprising a plurality of further cylindrically shaped protuberances projecting laterally outwardly from the circular peripheral wall of the block and spaced circumferentially therearound, each said further protuberance having a circumferential ridge extending around its cylindrical wall.
6. A toy building element according to claim 4 or claim 5 further comprising a plurality of circumferentially spaced cylindrical cavity forming walls projecting laterally outwardly from the cylindrical side wall of the block and defining further cylindrical cavities for receiving, with a press-fit, protuberances of another toy building element.
7. A toy building element according to claim 6 wherein there is a pair of said further protuberances and a pair of said further cylindrical cavities, the protuberances and cavities of each said pair being diametrically opposite one another.
8. A toy building element according to claim 1 wherein each of the protuberances has a cylindrical side wall.

Patentansprüche

1. Spielzeugbauelement, umfassend einen hohlen Block (10) mit einem geschlossenen oberen Ende (11), einem offenen unteren Ende (12) und einer peripheren Seitenwand (13,14), die das obere und das untere Ende miteinander verbindet, wenigstens eine Ausstülpung (15), die von dem genannten oberen Ende vorsteht, wenigstens einen nach unten öffnenden Hohlraum (21), der von dem offenen unteren Ende des Blocks nach innen verläuft, wobei die oder jede Ausstülpung eine Umfangsrippe (18) aufweist und der bzw. jeder Hohlraum eine innere Umfangsnut (20) aufweist, wobei die Blöcke so dimensioniert und geformt sind, daß

- beim Zusammenfügen von zwei ähnlichen Elementen die oder jede Ausstülpung (15) in einen jeweiligen genannten Hohlraum (21) eingedrückt wird, wobei die Rippe (18) in eine zugehörige genannte Nut (20) eingreift, um die Elemente somit ineinanderzustecken, wobei die Elemente relativ zueinander um eine gemeinsame Achse des Hohlraums (21) und der damit im Eingriff befindlichen Ausstülpung (15) drehbar sind.
2. Spielzeugbauelement nach Anspruch 1, bei dem der genannte Block etwa ovalförmig ist und zwei genannte Ausstülpungen und zwei genannte Hohlräume hat, wobei die periphere Seitenwand ein Paar gegenüberliegender, parallel angeordneter Seitenwandabschnitte und ein Paar gegenüberliegender Endwandabschnitte umfaßt, wobei die genannten Endwandabschnitte konvex gekrümmt sind, wobei sich jede genannte Ausstülpung etwa im Krümmungsmittelpunkt eines jeweiligen genannten danebenliegenden gekrümmten Endwandabschnitts befindet.
3. Spielzeugbauelement nach Anspruch 2, bei dem jeder genannte Endwandabschnitt eine Aussparung oder einen Schlitz aufweist, die/der von seinem unteren Ende nach innen verläuft und für einen Eingriff durch ein Lösewerkzeug vorgesehen ist, um die Trennung von miteinander verbundenen Blöcken zu unterstützen.
4. Spielzeugbauelement nach Anspruch 1, bei dem der Block im Plan kreisförmig ist und eine einzelne Ausstülpung aufweist, die sich mittig auf dem oberen Ende des Blocks befindet, und einen einzelnen, mittig gelegenen genannten Hohlraum, der im offenen unteren Ende des Blocks einwärts verläuft und koaxial zur genannten einzelnen Ausstülpung ausgerichtet ist.
5. Spielzeugbauelement nach Anspruch 4, ferner umfassend eine Mehrzahl von weiteren zylindrisch geformten Ausstülpungen, die von der kreisförmigen peripheren Wand des Blocks lateral nach außen vorstehen und um dessen Umfang voneinander beabstandet angeordnet sind, wobei jede der genannten weiteren Ausstülpungen eine um ihre zylindrische Wand verlaufende Umfangsrippe aufweist.
6. Spielzeugbauelement nach Anspruch 4 oder 5, ferner umfassend eine Mehrzahl von um den Umfang voneinander beabstandet angeordneten zylindrischen hohlraumformenden Wänden, die von der zylindrischen Seitenwand des Blocks lateral nach außen vorstehen und weitere zylindrische Hohlräume definieren, die im Preßsitz Ausstülpungen eines anderen Spielzeugbauelementes aufnehmen.
7. Spielzeugbauelement nach Anspruch 6, das ein Paar der genannten weiteren Ausstülpungen und ein Paar der genannten weiteren zylindrischen Hohlräume umfaßt, wobei die Ausstülpungen und Hohlräume von jedem der genannten Paare einander genau gegenüberliegen.
8. Spielzeugbauelement nach Anspruch 1, bei dem jede der Ausstülpungen eine zylindrische Seitenwand hat.

Revendications

1. Un élément de construction de jouets comprenant un bloc creux (10) présentant une partie supérieure fermée (11), une partie inférieure ouverte (12) et une paroi latérale périphérique (13, 14) reliant les parties supérieure et inférieure, au moins une protubérance (15) dépassant de ladite partie supérieure et au moins une cavité s'ouvrant vers le bas (21) s'étendant vers l'intérieur à partir de la partie inférieure ouverte du bloc, chaque protubérance, ou la protubérance, ayant un rebord circonférentiel (18), et chaque cavité ou la cavité présentant une rainure circonférentielle interne (20), les blocs étant dimensionnés et façonnés de manière à ce que, lorsque deux éléments semblables sont assemblés l'un avec l'autre, chaque protubérance, ou la protubérance (15) s'emboîte par serrage à l'intérieur de ladite cavité respective (21), alors que le rebord (18) s'engage à l'intérieur de ladite rainure associée (20) afin de verrouiller ainsi les éléments ensemble, les éléments pouvant être tournés l'un par rapport à l'autre autour d'un axe commun à la fois pour la cavité (21) et la protubérance (15) qui y sont engagés.
2. Un élément de construction de jouets, selon les stipulations de la revendication 1, dans lequel ledit bloc présente une forme à peu près ovale et possède deux protubérances et deux cavités, dans lequel la paroi latérale périphérique comprend deux sections de parois latérales parallèles et opposées et deux sections de parois d'extrémité opposées, dans lequel lesdites sections de parois d'extrémité ont une courbure convexe, alors que chaque protubérance est disposée environ au centre de la courbe d'une section de paroi d'extrémité courbée respective adjacente à celle-ci.
3. Un élément de construction de jouets, selon les stipulations de la revendication 2, dans lequel chaque section de paroi d'extrémité est munie d'un évidement ou d'une fente se prolongeant vers l'intérieur à partir de sa partie inférieure, afin de permettre l'introduction d'un outil de libération destiné à faciliter la séparation des blocs quand ils ont été assemblés ensemble.

4. Un élément de construction de jouets, selon les stipulations de la revendication 1, dans lequel le bloc a un plan circulaire, et comporte une seule protubérance située au centre sur la partie supérieure du bloc, et une seule cavité située au centre et se prolongeant vers l'intérieur à partir de la partie inférieure ouverte du bloc, et étant alignée de façon coaxiale avec ladite seule protubérance. 5
5. Un élément de construction de jouets, selon les stipulations de la revendication 4, comprenant en outre une pluralité d'autres protubérances de forme cylindrique se projetant latéralement vers l'extérieur à partir de la paroi périphérique circulaire du bloc, et espacées sur la circonférence de cette dernière, chacune desdites autres protubérances présentant un rebord circonférentiel s'étendant autour de sa paroi cylindrique. 10 15
6. Un élément de construction de jouets, selon les stipulations de la revendication 4 ou de la revendication 5, comprenant en outre une pluralité de parois formant cavité cylindrique, espacées sur la circonférence, se projetant latéralement vers l'extérieur à partir de la paroi latérale cylindrique du bloc et définissant d'autres cavités cylindriques destinées à recevoir, par ajustement par pression, les protubérances d'un autre élément de construction de jouets. 20 25 30
7. Un élément de construction de jouets, selon les stipulations de la revendication 6, dans lequel il existe deux autres desdites protubérances et deux autres desdites cavités cylindriques, les protubérances et les cavités de chaque paire étant diamétralement opposées l'une par rapport à l'autre. 35
8. Un élément de construction de jouets, selon les stipulations de la revendication 1, dans lequel chacune des protubérances présente une paroi latérale cylindrique. 40

45

50

55

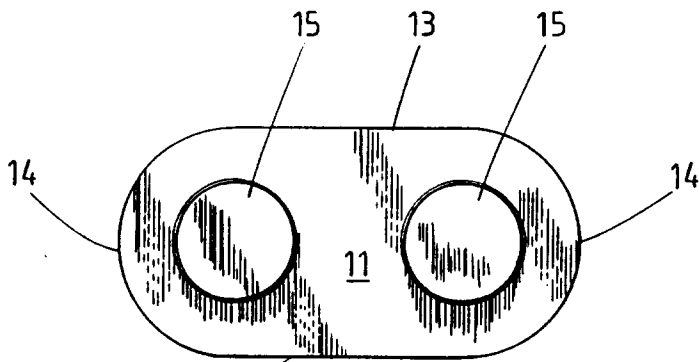

FIG 3a

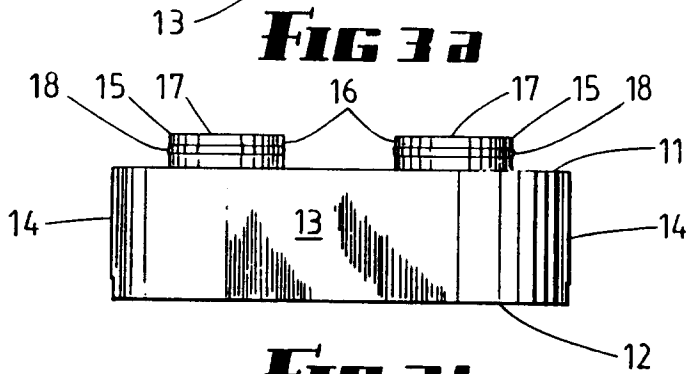

FIG 3b

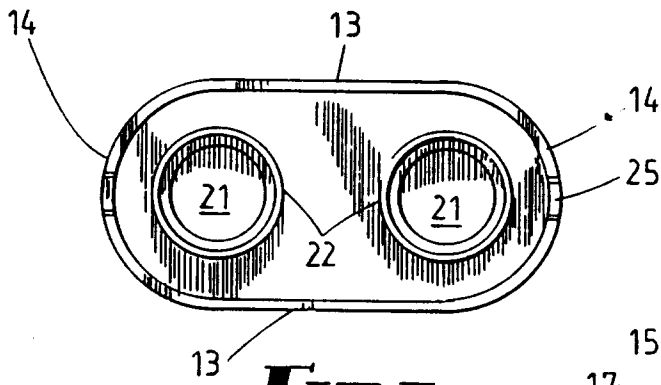

FIG 3c

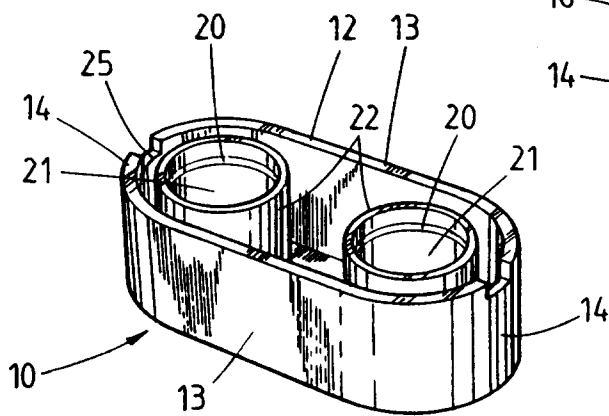

FIG 2

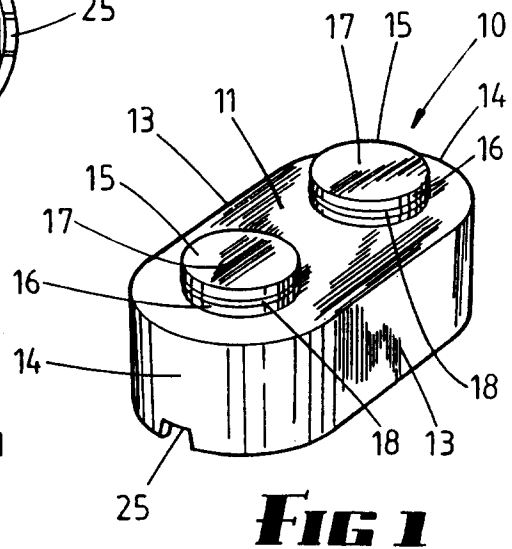

FIG 1

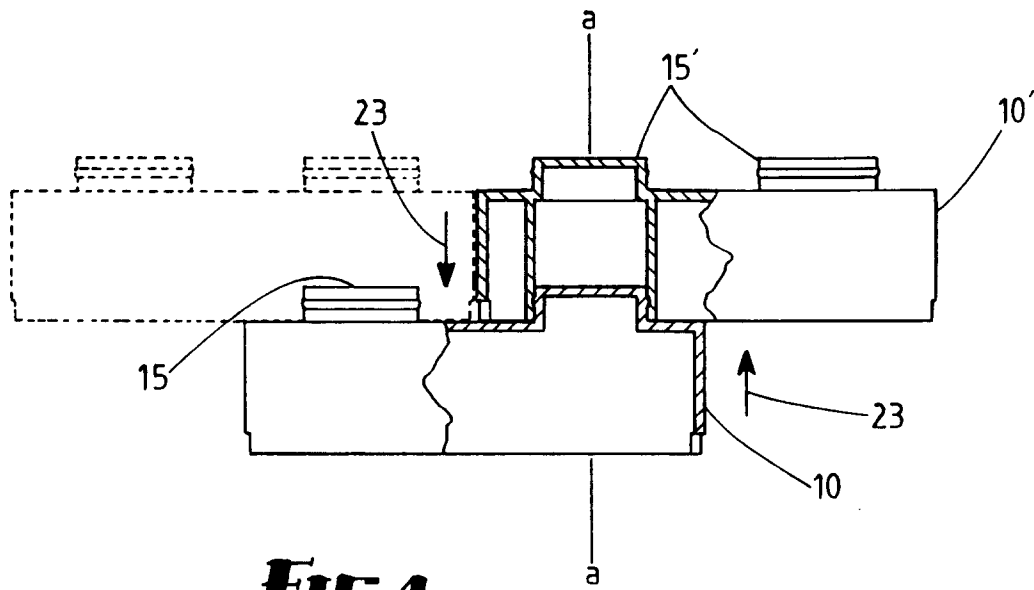

FIG 4

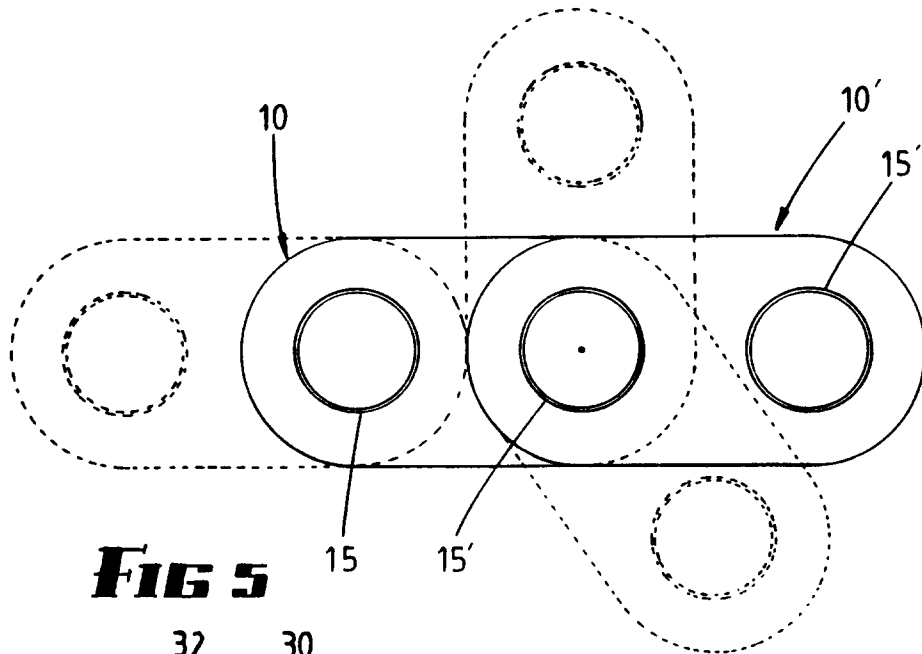

FIG 5

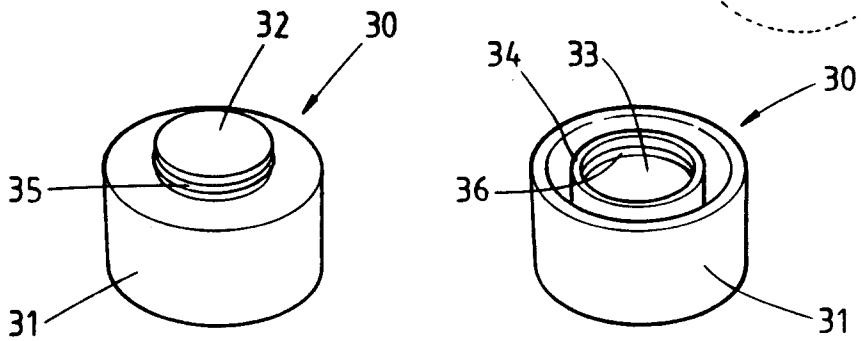

FIG 6a

FIG 6b

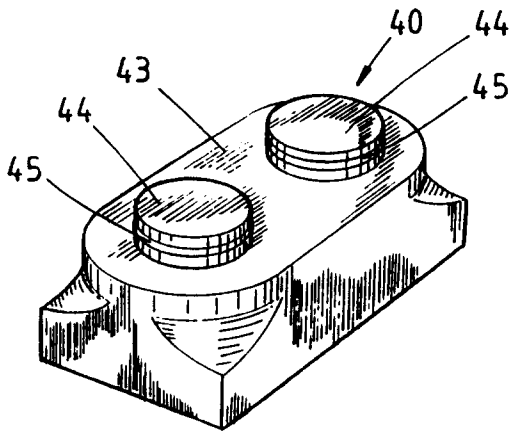

FIG 7a

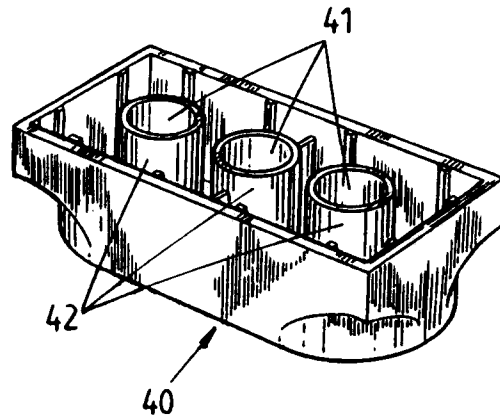

FIG 7b

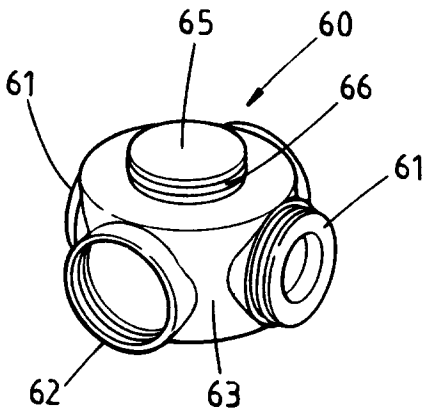

FIG 8a

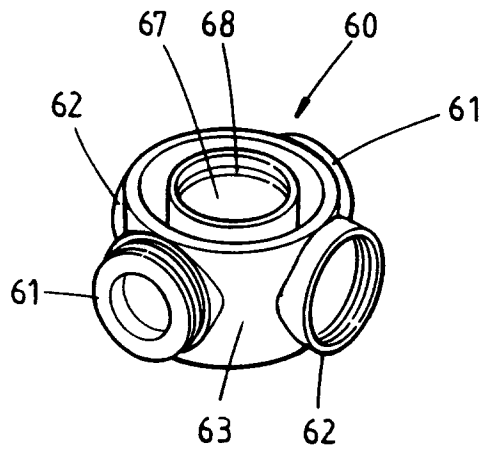

FIG 8b

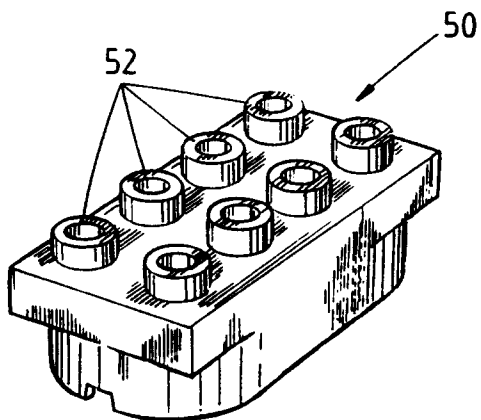

FIG 9a

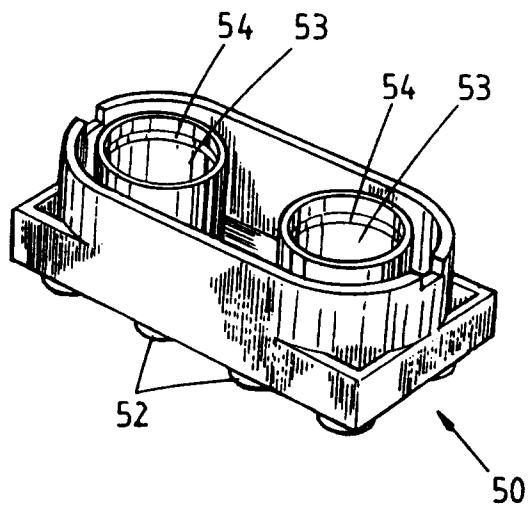

FIG 9b