

(19)



Europäisches Patentamt
European Patent Office
Office européen des brevets



(11) **EP 0 647 563 B1**

(12)

EUROPEAN PATENT SPECIFICATION

(45) Date of publication and mention
of the grant of the patent:
16.07.1997 Bulletin 1997/29

(51) Int. Cl.⁶: **B65B 51/06**

(21) Application number: **94202905.9**

(22) Date of filing: **07.10.1994**

(54) **Adhesive paper sealing machine for parallelepiped boxes with turn-down flaps**

Siegelmaschine zur Verwendung von Klebestreifen aus Papier für quaderförmige Schachteln mit
umfaltbaren Verschlussklappen

Machine de scellage de papier adhésif pour boîtes parallélépipédiques avec des volets rabattables

(84) Designated Contracting States:
DE FR GB IT

(30) Priority: **12.10.1993 IT MI932156**

(43) Date of publication of application:
12.04.1995 Bulletin 1995/15

(73) Proprietor: **Marchetti, Augusto**
I-20146 Milano (IT)

(72) Inventor: **Marchetti, Augusto**
I-20146 Milano (IT)

(74) Representative: **Mittler, Enrico et al**
c/o Mittler & C. s.r.l.,
Viale Lombardia, 20
20131 Milano (IT)

(56) References cited:
EP-A- 0 558 122 **GB-A- 1 195 971**

EP 0 647 563 B1

Note: Within nine months from the publication of the mention of the grant of the European patent, any person may give notice to the European Patent Office of opposition to the European patent granted. Notice of opposition shall be filed in a written reasoned statement. It shall not be deemed to have been filed until the opposition fee has been paid. (Art. 99(1) European Patent Convention).

Description

The present invention relates to an adhesive paper sealing machine for parallelepiped boxes with turn-down flaps.

It is known that ecological problems have caused a return to favour of adhesive paper sealing tapes (paper tapes provided with a small layer of adhesive applied to one of the faces), that for years had been abandoned in favour of plastic adhesive tapes.

In the European patent application No. 0558122 a sealing machine was described using an adhesive paper taping device that comprises a plurality of individual separately dismantable units, among which a unit for supporting a roll of adhesive paper tape, units for controlling, centering and feeding the tape itself, a contrasting unit co-operating with the feeder unit, a unit for shearing and a unit for moistening the tape, and lastly a unit for applying the tape to the top of the box to be sealed. A similar taping device can also be provided for sealing the bottom of the box.

During the operation of such a machine, a box to be sealed is made to advance by a pair of lateral belts along a set of rollers, and it presses in sequence a first and a second microswitch.

The operation of the first microswitch determines the operation of the tape feeder unit of each taping device, that causes the tape itself to advance, unwinding it from the roll, by an amount of a predetermined length; during the tape advance, its surface provided with glue is made to become adhesive through the action of the moistening unit, so that, when the box arrives, it can glue itself on the front surface of the same box, by exploiting the pressure of a roller forming part of the tape application unit. The further advance of the box determines the operation of the second microswitch, that releases the movement of the tape inside the machine, so that the advance of the box causes the free unwinding of the tape from the roll, to allow the tape to be glued on the upper surface of the box and possibly also the lower one. At the end the tape is sheared off, and the machine is ready to start a new cycle.

The problem exhibited by the described machine is linked with the fact that, especially with tapes whose adhesive is of poor quality, the resistance offered to the action of unwinding the tape could, during the advancement of the box, cause the section of the tape that is not yet perfectly glued on the front surface to come unstuck, determining the failure of the entire sealing operation.

In view of the described state of the art, the object of the present invention is to provide an adhesive paper sealing machine that is not affected by the abovementioned problem.

According to the present invention such object is attained thanks to an adhesive paper sealing machine for parallelepiped boxes with turn-down flaps, comprising a supporting base for the boxes to be sealed, means for the advancement of the boxes associated with said supporting base, a head that can be displaced vertically

at a variable distance with respect to said supporting base, at least one taping device supported by said head and comprising a unit for supporting a roll of tape of adhesive paper, a unit for feeding the tape, a contrasting unit co-operating with the unit feeding the tape, a unit for shearing the tape, a unit for moistening the tape and a unit for applying the moistened tape on the box to be sealed, said machine also comprising sensor means, excited by the boxes during the advancement, for the activation and disactivation of said feeder unit and said contrasting unit and for the activation and disactivation of said shearing unit, characterized in that said roll of tape is mounted in the supporting unit in a freely rotatable manner so that, following the activation and subsequent disactivation of the feeder and contrasting units for unwinding the initial section of the tape from the roll, the roll continues its rotation due to inertia so as to obtain, between the supporting unit and the feeder unit, a section of loose tape that is subsequently recovered by the advancing box without opposing any resistance, said supporting unit also comprising braking means controlled by said sensor means to stop the inertial rotation of the roll of tape when the operation of sealing a box has been completed.

In a sealing machine according to the invention, the presence of the loose section of adhesive paper tape (an abundance of tape) is such that, at least initially and until such abundance has not exhausted itself, the tape recovered by a box to be sealed is not held back by the inertia and by the roll rotation friction, thus preventing the initial tape section just applied to the front of the box from coming unstuck from the box itself.

The features of the present invention will be made more evident by the following detailed description of an embodiment thereof, illustrated as a non-limiting example in the enclosed drawings, wherein:

Fig. 1 is a plan view of a supporting base of a sealing machine according to the invention;

Fig. 2 is a cross-sectional view of said sealing machine taken along the vertical longitudinal plane II-II of Fig. 1, in a first operational condition;

Fig. 3 is similar to Fig. 2, with the machine in a second operational condition;

Fig. 4 is similar to Figs. 2 and 3, with the machine in a third operational condition;

Fig. 5 shows in detail a taping device of said machine, in the operational condition of Fig. 2;

Fig. 6 is similar to Fig. 5, but it refers to the operational condition of Fig. 3;

Fig. 7 is similar to Figs. 5 and 6, but it refers to the operational condition of Fig. 4;

Fig. 8 is a cross-sectional view of a unit for supporting a roll of tape taken along the line VIII-VIII of Fig. 2;

Fig. 9 shows said supporting unit in a rear view with respect to Fig. 2;

Fig. 10 is a plan view of the supporting unit;

Fig. 11 is an overall diagramme of a pneumatic cir-

cuit for operating some of the units of the taping device of Figs. 5-7.

With reference to the drawings, and in particular to Figs. 1-4, a sealing machine according to the invention comprises a supporting base 1 that defines a set of rollers 2 for the boxes to be sealed, and a pair of lateral advancement units 4, provided with respective belts 5, superimposed over said supporting base 1 and that can be moved reciprocally closer to one another, by rotating a crank 6, to allow the belts 5 to engage with opposite sides 7 of a box 3 with the purpose of causing the latter to advance along said supporting base 1 in the direction of the arrow A. Along one of the advancement units 4 there are in succession a first microswitch M1 and a second microswitch M2, both provided with an operating lever 201 extending above the set of rollers 2 in a direction orthogonal to the direction in which the boxes advance.

The machine also comprises a head 8 (Figs. 2-4) fastened to two lateral pillars 9 in a position equidistant from them; the pillars 9 can slide vertically within respective guides 10 to arrange the head 8 at a variable distance from the supporting base 1, so as to allow the passage of boxes to be sealed having variable height.

An upper taping device 11, designed for feeding sections of tape of adhesive paper 13 from a roll 14, is fastened to a pair of arms 12 protruding from the head 8. A similar lower taping device is housed under the set of rollers 2 of the supporting base 1, and is accessible through an opening 130 in the set of rollers (Fig. 1).

The taping device 11 is constituted by a plurality of individual units, separately dismantlable to allow for maintenance of the device itself, fastened to a lateral supporting shoulder 15 to which on the opposite side there corresponds a lower containment shoulder 16; the two shoulders 15 and 16 are loosely fastened to the two protruding arms 12 (or to special supports 200 in the supporting base 1, in the case of the lower feeder unit).

The units of the device 11 are: a unit 17 for supporting the roll 14 of the tape 13 of adhesive paper; a unit 99 for tightening the tape; a unit 18 for centering the tape 13; a pair of co-operating plates 19 and 20 for the guidance and movement of the tape 13; a unit 21 for feeding the tape 13 and a contrasting unit 22 associated with the two plates 19 and 20, respectively, to determine the intermittent advancement of the tape 13 in relation to the operating cycle of the machine; a shearing unit 23 to separate sections of the tape 13 having a pre-determined length from the continuous tape taken from the roller 14; a moistening unit 24 for moistening the face of the tape 13 provided with adhesive; and an application unit 25 suitable for executing the application of the separated and moistened section of tape 13 on the box 3 to be sealed.

As shown in Figs. 5-10, the supporting unit 17 consists of an arm 90, fastened to the lateral shoulder 15, at the upper end of which a horizontal hub 91 is fastened. On the hub 91 there are mounted two plates 92 and 93,

of which the first is fixed and the second is freely slidable, for the lateral containment of the roll 14 of adhesive paper, having a diameter just larger than the diameter of the latter; the plate 93 can be removed from the hub 91 to allow the installation of the roll 14; on the inner face of the plate 92, thanks to two screws 94 placed in diametrically opposed positions, a flexible disc 95 is fastened. The plate 92 is also provided with a circular opening 96 located along a radial direction orthogonal to the direction joining the two screws 94; such opening allows the passage of a piston 97 of a pneumatic cylinder 98 fastened to the plate 92. Such piston 97, when operated, pushes up against the disc 95 and elastically deforms it (Fig. 10), to allow, as will be shown later, a braking of the roll 14. To the plate 92 there is also fastened a pivot 107 that supports an idle coaxial roller 108 for returning the tape 13 toward the tape tightening unit 99. The roll 14 is mounted on the hub 91, inside the two plates 92 and 93, in a freely rotatable manner and with the face provided with adhesive facing toward the outside of the roll, so that said face provided with adhesive faces toward the moistening unit 24 and toward the front wall of the box 3 advancing along the supporting base 1.

The tape tightening unit 99, visible in Figs. 5-7, consists essentially of a lever 100 hinged at 102 to a metal housing 103 in turn fastened with screws and nuts to a box-like metal casing 37 containing the feeder unit 21; the upper end of the lever 100 has an idle roller 101 for moving the tape 13, while a spring 104 urges the same lever 100 to a position suitable for ensuring, at rest and during the taping operation, the tension of the tape 13 fed from the roll 14. On the housing 103 there are also two other idle rollers 105 and 106 to return the tape 13 toward the centering unit 18.

The centering unit 18, known in itself, is identical to the centering unit of the machine described in the European patent application No. 0558122; it comprises an external support 26 fastened to the lateral shoulder 15 and an internal support 27 fastened to the first in an adjustable manner thanks to a bolt 203 and also fastened to the shoulder 15 thanks to a pivot 29 having one threaded end (not visible in the drawings), on which there is rotatably mounted an idle roller 29 provided with lateral shoulders 30 for holding and guiding the tape 13. By loosening the bolt 203 and screwing up the pivot 29, the internal support 27 slides inside the external support 26, it moves the idle roller 29 and thus guiding the tape 13 of adhesive paper to the desired position.

The pair of co-operating plates 19 and 20 consists of a lower fixed plate 20 separably fastened to the lateral shoulder 15, and by an upper movable plate 19 rotatable with respect to a horizontal pivot 31 separably fastened to the shoulder 15, that also acts as the support for an idle roller 32 for returning the tape 13. The two plates 19 and 20 are at angle of about 40° to allow an easier movement of the tape 13, and they have respective central openings 33 and 34, whose purposes will be explained later in connection with the description of the feeder and contrasting units 21 and 22.

Two chutes 35 and 36 located at the exit from the plates 19 and 20 co-operate for a fixed contrasting guide 65 to displace the tape 13 at an angle so as to present it orthogonal to the moistening unit 24 and to the direction of translation of the box 3.

The feeder unit 21 of the tape 13 comprises, as already said, the box-like metal casing 37 fastened through nuts and screws to a corresponding casing of the underlying shearing unit 23. Inside the box-like casing 37 there is a twin-action pneumatic cylinder 38, whose stem is connected by means of an articulated joint to a pivot 39 protruding frontally in an eccentric position from a semicircular gearwheel 40 that directly meshes with a toothed wheel 41 with a lower diameter to which there is eccentrically and integrally fastened a unidirectional wheel 42 that passes through the opening 33 of the plate 19.

An abutment screw with a knob 43 fastened in an adjustable manner to the casing 37 allows the adjustment of the stroke of the cylinder 38 to be made, and thus the angular stroke of the wheel 42, and as a consequence the length of the section of the tape T that, due to the operation of the feeder unit 23, protrudes vertically in front of the application unit 25 (Fig. 6).

The contrasting unit 22 comprises a box-like metal casing 44 wherein there is a single-action pneumatic cylinder 45 with an elastic return stroke, whose stem is coupled by means of an articulated joint with a pivot 46 that extends between two bracket levers 47 hinged at 60 on the casing 44. On the abovementioned levers 47 a rubber wheel 49 is rotatably mounted that protrudes through the opening 34 of the plate 20 to exert a contrasting action with the wheel 42 of the feeder unit 21 for the advancement of the tape 13.

The linear movement of the cylinder 45 is transformed in a movement whereby the wheel 49 is moved closer to or farther away from the wheel 42, thus allowing the movement or otherwise of the tape 13 of adhesive paper in synchronisation with the operation of the unit 21.

The unit 23 for shearing the tape 13 comprises a box-like metal casing 50 to which there is separably fastened the casing 37 of the feeder unit 21 of the tape and which is in turn separably fastened to the movable plate 19. Inside the casing 50 there is a twin-action pneumatic cylinder 51, whose stem is coupled by means of an articulated joint to a pivot 52 that extends between two connecting rods 53 hinged at 54 on a pair of levers 55 hinged at 56 and integrally holding a shearing blade 57 co-operating with a fixed counterblade 58 under the thrust of a spring 59 acting on the blade holding levers 55. Under the thrust of the cylinder 51 the connecting rods 53 push the blade 57 to shear the tape 13 of adhesive paper with the assistance of the counterblade 58 against which the blade 57 is pressed by the spring 59.

The moistening unit 24 consists of a bowl 60 with a lateral hole 61 to which a water feeder line 62 is connected. On the bowl 60 there is an electrical resistance 63 to heat the moistening water so as to obtain a better

activation of the glueing mass associated with the tape 13 of adhesive paper. There is a brush 64 in the bowl's water that by capillarity brings water into contact with the tape 13 against the contrasting guide 65, inside which there is also an electrical resistance 66.

The unit 25 for the application of the moistened tape consists of a first lever 67 with an idle rubber-coated roller 68, a second lever 69 with an idle rubber-coated roller 70, a centre of rotation 71 that is common to the two levers 67 and 69, and a spring 72 that when at rest keeps the levers 67 and 69 in the close-up position shown in Fig. 5.

A gearwheel 73 integral with the lever 67 and rotatable with the same on the centre of rotation 71 is connected to a toothed wheel 74 centred at 75 through a chain 76, to which the stem of a pneumatic cylinder 78 hinged at 79 on the shoulders 15 and 16 is fastened at 77. On the lever 69 there is also mounted a pneumatic valve 80.

In the at rest position the cylinder 78 is activated and its stem is retracted so as to keep the levers 67 and 69 in the starting position, as shown in Fig. 5.

Moved by the belts 5 the box 3 acts on the roller 70 of the lever 69, causing the rotation of the latter on the centre of rotation 71 sufficient for the disactivation of the valve 80, that releases air from the cylinder 78.

Once the box 3 has cleared completely, the lever 67 under the action of the spring 72 is again joined together with the lever 69 determining through the chain 76 the extension of the stem of the cylinder 78 and thus reactivating the valve 80, that operates the retraction of the stem of the cylinder 78, that acting on the chain 76 through the connecting point 77 takes the levers 67, 69 back to the starting position.

With the tape application unit 25 there is associated a brush 81 for pressing the tape over the box 3, that is fastened to a lever support 82 hinged at 83 on the shoulders 15 and 16 and urged in the position shown in Fig. 5 by a spring 84 reacting against a fixed pivot 85.

With the assembly consisting of the shearing unit 23, of the feeder unit 21, of the movable plate 19 and of the tape tightening unit 99 there co-operates a release unit 206 consisting of a pneumatic cylinder 207 hinged at 208 on the lateral shoulder 15 and with stem connected at 209 by means of an articulated joint to a bracket 210 fastened to the metal casing 37 of the feeder unit 21. The operation of the cylinder 207, suitably timed, allows, after a preset time has elapsed after the end of the last operating cycle completed by the machine, to execute the opening of the path of the tape 13 between the plates 19 and 20 (the units 99, 21 and 23 rotate together with the movable plate 19 round the centre of rotation 31), so as to prevent or in any case to eliminate any possible jammings of the tape 13. Such opening can also be used for purposes of periodic maintenance of the feeder unit 11.

Between the shoulders 15 and 16 there is lastly mounted a support 86 on which there is a plurality of solenoid valves E to operate the various pneumatic cyl-

inders described above during the cycle of operation of the machine. A few solenoid valves of said plurality are shown in the overall diagramme of Fig. 11. In particular, one solenoid valve E1, interlocked with the first microswitch M1, controls the flow of air in the twin-action cylinder 38 to determine the extension or retraction of the corresponding stem; a second solenoid valve E2, interlocked with the second microswitch M2, controls the flow of air both in the twin-action cylinder 51 and in the single-action cylinder with an elastic return stroke 98; a third solenoid valve E3, also interlocked with the second microswitch M2, controls the flow of air in the single-action cylinder with an elastic return stroke 45. With the cylinder 38, and with the cylinder 98 as well, there are associated flow regulators 300 for regulating the sliding speed of the corresponding stems; with the cylinder 51, on the other hand, there is associated a quick-action element 301 that allows the sharp extension of the stem necessary to execute the shearing of the tape 13.

In operation, a box 3 to be sealed is placed on the rollers 2, and is made to advance by the belts 5 under the head 8 of the machine. Before the box 3 operates the first microswitch M1 (Fig. 2), the upper taping unit 11 (as well as the lower one) is in the condition shown in Figs. 2 and 5.

The front wall of the box 3, advancing along the rollers, operates the lever 202 of the first microswitch M1 (Fig. 3). The latter triggers the solenoid valve E1 associated with the feeder unit 21; the solenoid valve E1 operates the cylinder 38 so as to determine the return of its stem; through the semicircular gear 40 and the toothed wheel 41, this causes the rotation of the wheel 42 which, thanks to the contrasting action executed by the rubber wheel 49, determines the advancement of the tape 13 toward the chutes 35 and 36 by an amount whose length is preset by the knob screw 43; the tape 13, having gone through the chutes 35 and 36, runs between the guide 65 and the brush 64, which moistens the adhesive on the same tape 13, and exits under the feeder unit 11 so that a section T of moistened tape 13 hangs vertically at a given point of the path of the advancement of the box 3 (Figs. 3 and 6).

The rotation of the two co-operating wheels 42 and 49 unwinds some tape 13 from the roll 14; the resistance opposed by the latter to the unwinding of the tape 13 determines an urge on the lever 100 that rotates slightly on its fulcrum 102 and moves closer to the roll 14. When the rotation of the wheels 42 and 49 is complete, the lever 100 is returned to the at rest position by the spring 104, while the rotation of the roll 14, freely rotatable on the hub 91, continues by inertia so as to determine a looseness 205 of tape 13 that is not tight between the roll 14 and the entry to the plates 19 and 20.

With a further advancement along the rollers, the box 3 meets the section of hanging moistened tape 13, that adheres to the front wall of the same box 3, exploiting the pressure exerted by the roller 70 on the lever 69, urged, as already said, by the spring 72.

At this point the box 3 operates the lever 202 of the second microswitch M2 (Fig. 4) which, activating the solenoid valve E3, determines the release of the air from cylinder 45; this returns elastically to the at rest position, causing the rotation of the levers 47 and as a consequence the displacement of the rubber wheel 49 away from the wheel 42. The tape 13 can thus run freely between the plates 19 and 20 (Fig. 7).

The subsequent forward movement of the box 3 calls for tape 13; this initially determines the elimination of the looseness 205, and only later the unwinding of tape 13 from the roll 14. In this way the tape required initially by box 3 does not exert any resistance to the traction on the part of the box 3, thus preventing the section T glued on the front wall of the box 3 from coming unstuck. When, having eliminated the looseness 205, the tape 13 called for by the box 3 must be unwound from the roll 14, the resistance to traction must no longer be overcome by the mere section of tape glued on the front surface, but also by a section of tape glued to the upper surface of the box 3. This naturally also holds for the section of tape glued to the lower surface of the box.

The tape 13 called for by box 3 passes in front of the brush 64, that moistens the adhesive present on the face of the same tape.

When the box 3 is beyond the first microswitch M1 (Fig. 4) releasing the respective operating lever 202, the solenoid valve E1 operates the extension of the stem of the cylinder 38, to return the feeder unit 21 to the starting position (Fig. 7).

When the second microswitch M2 is also released by the box 3, this determines the operation of the solenoid valve E3, that returns the wheel 49 to the contrasting position with the wheel 42 (Fig. 5), and simultaneously the operation of the solenoid valve E2 that controls both the flow of air to the cylinder 51, and consequently the operation of the blade 57 to execute the shearing of the tape 13, and the flow of air to the cylinder 98 so as to operate the piston 97 to determine, through the deformation of the disc 95 (Fig. 10), a braking action on the rotation of the roll 14, which would otherwise continue to rotate by inertia and feed further sections of tape 13 that would create an undesired looseness.

The rear edge of tape is applied to the rear wall of the box 3 by the roller 68, urged by the spring 72 to adhere to said rear wall.

When the box has moved past the brush 81, the cylinder 78 returns the levers 67 and 69 to the initial position of Fig. 5, in the manner already described.

At this point the machine is ready to start a new operating cycle.

55 Claims

1. Adhesive paper sealing machine for parallelepiped boxes (3) with turn-down flaps, comprising a supporting base (1) for the boxes (3) to be sealed,

means (5) for the advancement of the boxes associated with said supporting base (1), a head (8) that can be displaced vertically at a variable distance with respect to said supporting base (1) and at least one taping device (11) supported by said head (8) and comprising a unit (17) for supporting a roll (14) of tape (13) of adhesive paper, a unit (21) for feeding the tape (13), a contrasting unit (22) serving to determine the intermittent advancement of the tape in relation to the operating cycle co-operating with the unit (21) feeding the tape (13), a unit (23) for shearing the tape (13), a unit (24) for moistening the tape (13) and a unit (25) for applying the moistened tape (13) on the box (3) to be sealed, said machine also comprising sensor means (M1, M2), excited by the boxes (3) during the advancement, for the activation and deactivation of said feeder unit (21) and of said contrasting unit (22) and for the activation and deactivation of said shearing unit (23), characterized in that said roll (14) of tape (13) is mounted in the supporting unit (17) in a freely rotatable manner so that, following the activation and subsequent deactivation of the feeder unit (21) and of the contrasting unit (22) for unwinding the initial section (T) of the tape (13) from the roll (14), the roll (14) continues its rotation due to inertia so as to obtain, between the supporting unit (17) and the feeder unit (21), a section (205) of loose tape that is subsequently recalled by the advancing box (3) without opposing any resistance, said supporting unit (17) also comprising braking means (98, 95) controlled by said sensor means (M1, M2) to stop the inertial rotation of the roll (14) of tape (13) when the operation of sealing a box (3) has been completed.

2. Machine according to claim 1, characterized in that said supporting unit comprises a hub (91) on which said roll (14) of tape (13) can freely rotate, as well as two lateral containment plates (92, 93) mounted on said hub (91), said braking means (98, 95) comprising a flexible disc (95) integral with one of these plates (92) and urged to deflect by a pneumatic cylinder (98) to interfere with one lateral wall of the roll (14) and to stop its inertial rotation.
3. Machine according to claim 1, characterized in that between the supporting unit (17) of the roll (14) and the centering unit (18) there are elastic means (99) for keeping the tape (13) under tension.

Patentansprüche

1. Papierklebeband verwendende Verschließmaschine zum Verschließen von quaderförmigen Kisten (3) mit umfaltbaren Verschließklappen, umfassend ein Grundgestell (1) für die zu verschließenden Kisten (3), dem Grundgestell (1) beigeordnete Mittel (5) zur Vorwärtsbewegung der Kisten,

einen Kopf (8), der bezüglich dem Grundgestell (1) in einem variablen Abstand senkrecht verschoben werden kann und mit zumindest einer durch den Kopf (8) getragenen Bandabwickelvorrichtung (11), und umfassend eine Einrichtung (17) zum Tragen einer Rolle (14) aus Papierklebeband (13), eine Einrichtung (21) zum Zuführen des Bandes (13), eine Gegeneinrichtung (22), die zum Festlegen der intermittierenden Vorwärtsbewegung des Bandes in Bezug auf den Arbeitszyklus dient und mit der Einrichtung (21) zum Zuführen des Bandes (13) zusammenwirkt, eine Einrichtung (23) zum Abtrennen des Bandes (13), eine Einrichtung (24) zum Anfeuchten des Bandes (13) und eine Einrichtung (25) zum Aufbringen des angefeuchteten Bandes (13) auf der zu verschließenden Kiste (3), wobei die Maschine ebenso Sensormittel (M1, M2) umfaßt, die zur Aktivierung und Deaktivierung der Zuführeinrichtung (21) und der Gegeneinrichtung (22) und für die Aktivierung und Deaktivierung der Abtrenneinrichtung (23) während der Vorwärtsbewegung durch die Kisten (3) betätigt werden,

dadurch gekennzeichnet, daß die Rolle (14) aus Band (13) in der Trageinrichtung (17) in frei drehbarer Weise angebracht ist, so daß nach der Aktivierung und der anschließenden Deaktivierung der Zuführeinrichtung (21) und der Gegeneinrichtung (22) zum Abwickeln des Anfangsabschnitts (T) des Bandes (13) von der Rolle (14), die Rolle (14) aufgrund der Massenträgheit ihre Rotation fortsetzt, um so zwischen der Trageinrichtung (17) und der Zuführeinrichtung (21) einen losen Bandabschnitt (205) zu erhalten, der anschließend durch die sich vorwärts bewegende Kiste (3) ohne irgendwelchen Widerstand zu erfahren eingezogen wird, wobei die Trageinrichtung (17) ebenso durch die Sensormittel (M1, M2) gesteuerte Bremsmittel (98, 95) umfaßt, um die Trägheitsrotation der Rolle (14) aus Band (13) anzuhalten, wenn der Verschließvorgang einer Kiste (3) beendet wurde.

2. Maschine nach Anspruch 1, **dadurch gekennzeichnet, daß** die Trageinrichtung eine Nabe (91), auf der die Rolle (14) aus Band (13) frei drehen kann, wie auch zwei seitliche Aufnahmeplatten (92, 93) umfaßt, die auf der Nabe (91) befestigt sind, wobei die Bremsmittel (98, 95) eine flexible Scheibe (95) umfassen, die mit einer dieser Platten (92) fest verbunden ist und durch einen Pneumatikzylinder (98) gedrückt wird, um sich zu verformen, um so mit einer Seitenwand der Rolle (14) in Eingriff zu gelangen und damit deren Trägheitsrotation anzuhalten.
3. Maschine nach Anspruch 1, **dadurch gekennzeichnet, daß** zwischen der Trageinrichtung (17) der Rolle (14) und der Zentriereinrichtung (18) elastische Mittel (99) vorhanden sind, um das Band (13) unter Span-

nung zu halten.

Revendications

1. Machine à fermer par papier adhésif pour boîtes parallépipédiques (3) possédant des volets rabatables, comprenant une base de support (1) recevant les boîtes (3) à fermer, des moyens (5) servant à faire avancer les boîtes, associés à ladite base de support (1), une tête (8) qui peut être déplacée verticalement à une distance variable par rapport à ladite base de support (1), et au moins un dispositif de pose de bande (11) supporté par ladite tête (8) et comprenant une unité (17) destinée à supporter un rouleau (14) de bande (13) de papier adhésif, une unité (21) servant à faire avancer la bande (13), une unité de résistance (22), destinée à déterminer l'avancement intermittent de la bande en fonction du cycle de travail, qui coopère avec l'unité (21) d'avance de la bande (13), une unité (23) destinée à couper la bande (13), une unité (24) destinée à mouiller la bande (13) et une unité (25) destinée à appliquer la bande (13) mouillée sur la boîte (3) à fermer, ladite machine comprenant aussi des moyens capteurs (M1, M2), excités par les boîtes (3) pendant l'avancement, pour l'activation et la désactivation de ladite unité d'avance (21) et de ladite unité de résistance (22), et pour l'activation et la désactivation de ladite unité de coupe (23), caractérisée en ce que ledit rouleau (14) de bande (13) est monté dans l'unité de support (17) d'une façon librement rotative, de sorte qu'à la suite de l'activation et de la désactivation consécutive de l'unité d'avance (21) et de l'unité de résistance (22) servant à dévider la section initiale (T) de la bande (13) du rouleau (14), le rouleau (14) poursuit sa rotation par inertie de manière à obtenir, entre l'unité de support (17) et l'unité d'avance (21), une section (205) de bande détendue qui est ensuite rappelée par la boîte (3) en cours d'avance sans opposer de résistance, ladite unité de support (17) comprenant aussi des moyens de freinage (98, 95) commandés par lesdits moyens capteurs (M1, M2) pour arrêter la rotation du rouleau (14) de bande (13) par inertie lorsque l'opération de fermeture d'une boîte (3) a été entièrement exécutée.
2. Machine selon la revendication 1, caractérisée en ce que ladite unité de support comprend un moyeu (91) sur lequel ledit rouleau (14) de bande (13) peut tourner librement, ainsi que deux plaques de retenue latérales (92, 93) montées sur ledit moyeu (91), lesdits moyens de freinage (98, 95) comprenant un disque flexible (95) qui est d'un seul tenant avec une de ces plaques (92) et sollicité pour fléchir par un cylindre pneumatique (98) de manière à interférer avec une paroi latérale du rouleau (14) et à arrêter sa rotation par inertie.
3. Machine selon la revendication 1, caractérisée en ce que des moyens élastiques (99) sont agencés entre l'unité de support (17) du rouleau (14) et l'unité de centrage (18) pour maintenir la bande (14) sous tension.

Fig. 1

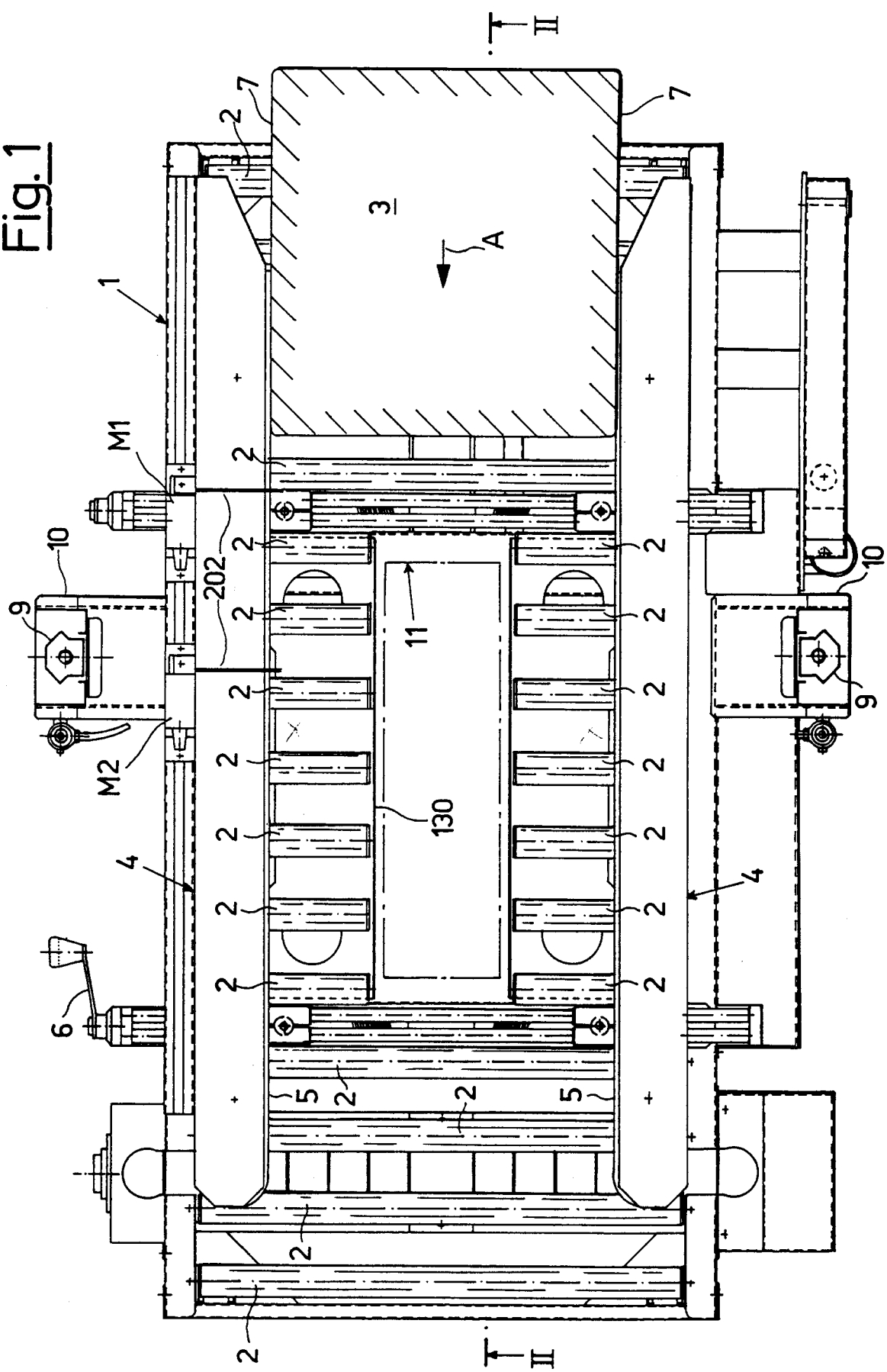

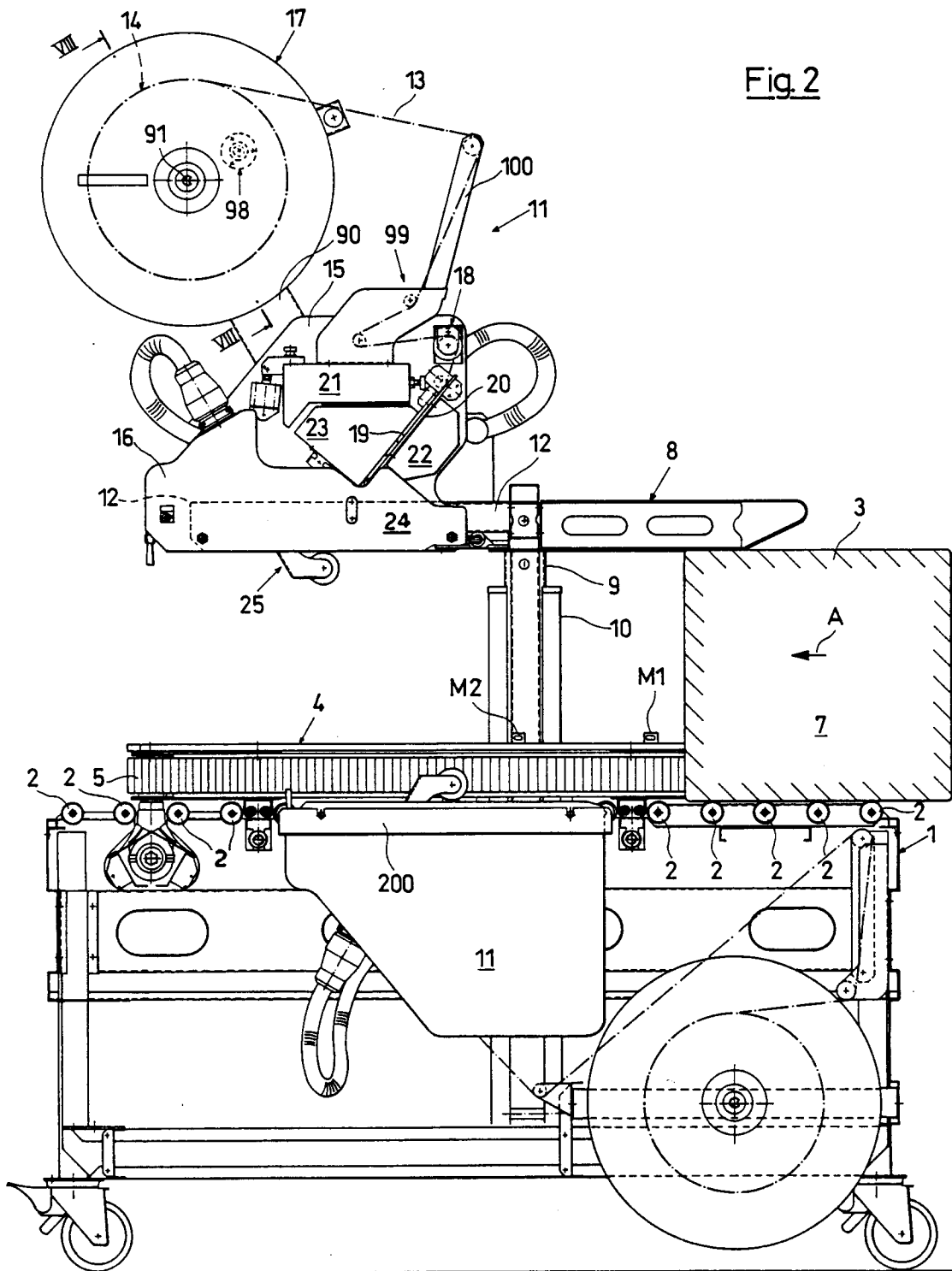

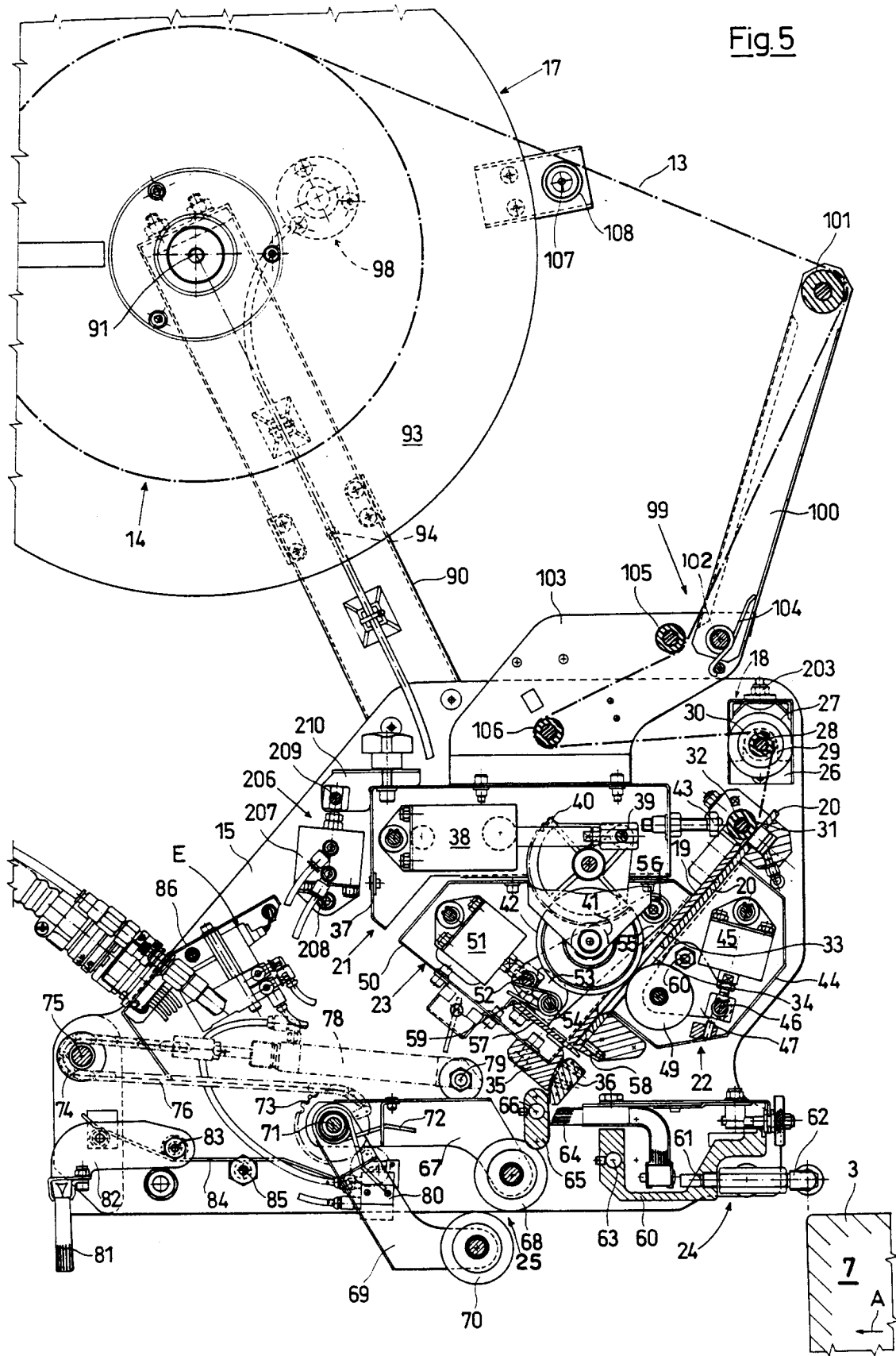

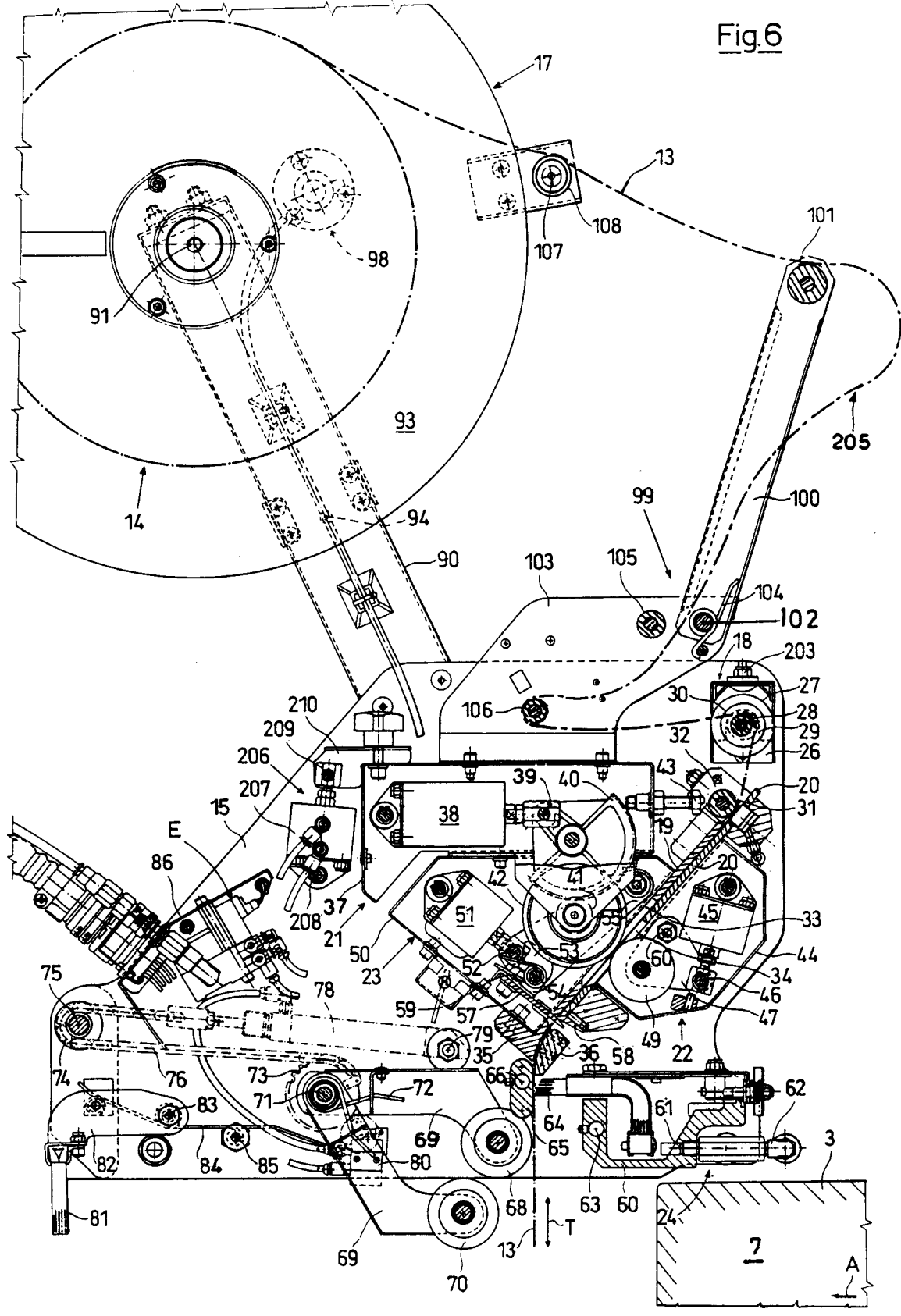

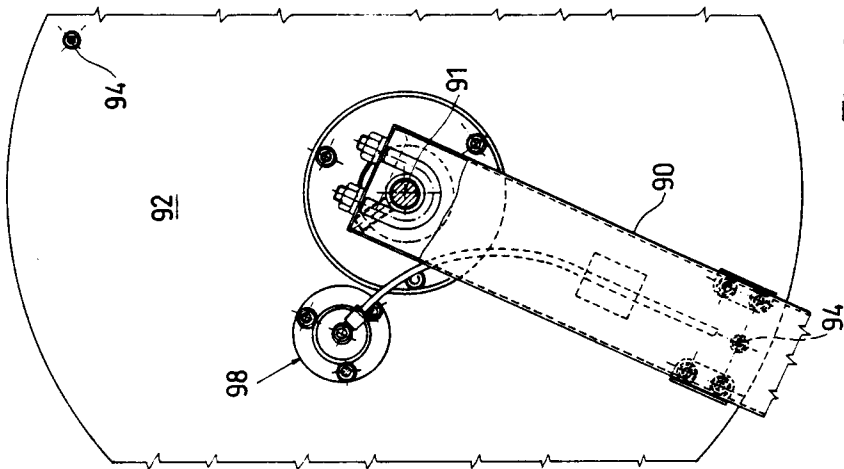

Fig. 9

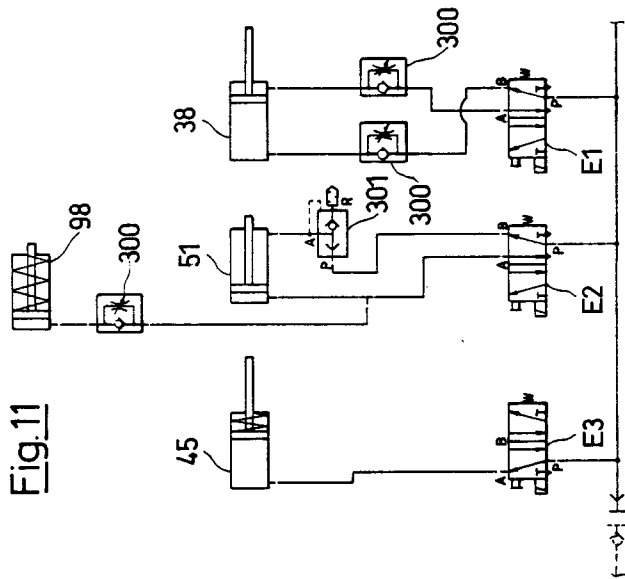

Fig. 11

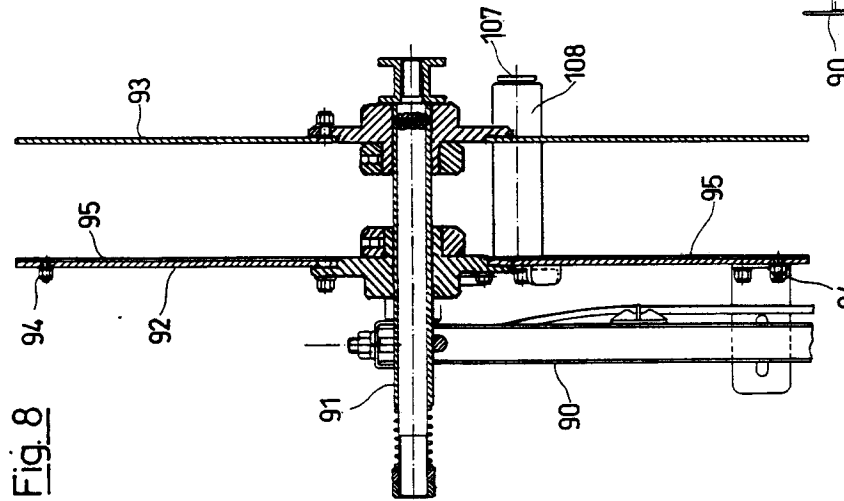

Fig. 8

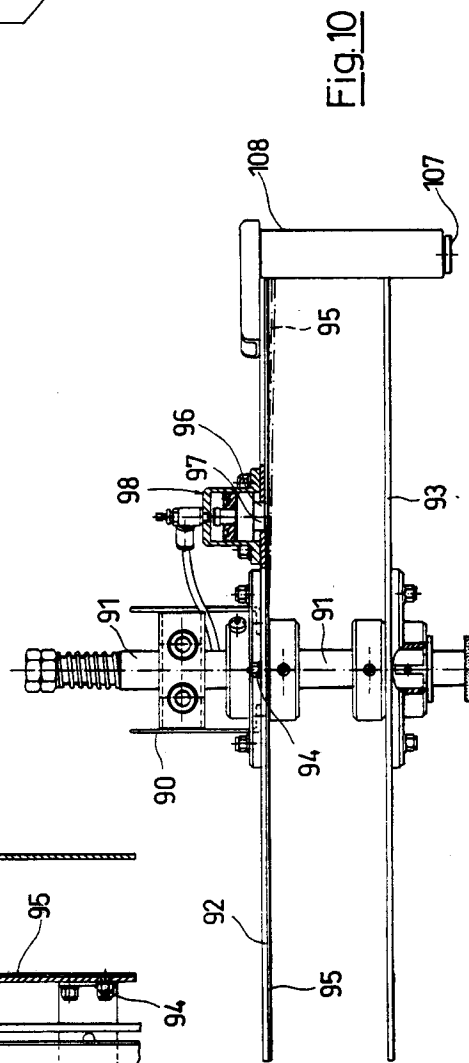

Fig. 10