

(19)



Europäisches Patentamt
European Patent Office
Office européen des brevets



(11)

EP 0 682 734 B1

(12)

EUROPEAN PATENT SPECIFICATION

(45) Date of publication and mention of the grant of the patent:
27.05.1998 Bulletin 1998/22

(51) Int Cl.6: **E04G 1/20**, E04G 1/26,
E06C 9/12

(21) Application number: **94905791.3**

(86) International application number:
PCT/GB94/00214

(22) Date of filing: **04.02.1994**

(87) International publication number:
WO 94/18417 (18.08.1994 Gazette 1994/19)

(54) **AN APPARATUS FOR ESCALADING**
VORRICHTUNG ZUM HOCHSTEIGEN
DISPOSITIF SERVANT A GRIMPER

(84) Designated Contracting States:
AT BE CH DE DK ES FR GB GR IE IT LI LU NL PT SE

(72) Inventor: **JEPHCOTT, David Lynton**
Market Drayton, Shropshire TF9 4QP (GB)

(30) Priority: **05.02.1993 GB 9302283**
22.06.1993 GB 9312822

(74) Representative: **Powell, Timothy John et al**
Eric Potter Clarkson,
Park View House,
58 The Ropewalk
Nottingham NG1 5DD (GB)

(43) Date of publication of application:
22.11.1995 Bulletin 1995/47

(60) Divisional application: **97202968.0 / 0 823 516**

(56) References cited:
EP-A- 0 061 358 DE-A- 3 420 737
DE-A- 3 838 283 DE-B- 1 224 667
DE-B- 1 292 581 DE-B- 1 295 482
US-A- 1 444 759 US-A- 2 616 769
US-A- 3 236 331 US-A- 3 548 970
US-A- 3 788 424 US-A- 4 125 173
US-A- 4 877 107 US-A- 5 067 587

(73) Proprietor: **SCOOTABOUT INTERNATIONAL LIMITED**
Oakley, Market Drayton,
Shropshire TF9 4AG (GB)

EP 0 682 734 B1

Note: Within nine months from the publication of the mention of the grant of the European patent, any person may give notice to the European Patent Office of opposition to the European patent granted. Notice of opposition shall be filed in a written reasoned statement. It shall not be deemed to have been filed until the opposition fee has been paid. (Art. 99(1) European Patent Convention).

Description

This invention relates to an apparatus for escalating.

The basic design of the ladder has been known for many years. The ladder has proved over many centuries to be one of the most useful inventions ever devised.

However, the ladder does suffer numerous disadvantages. Most notably, these disadvantages are concerned with the safety of users of ladders. There have been innumerable incidents of ladder users falling off ladders and suffering severe injuries, or sometimes even death.

One of the main causes of accidents amongst ladder users is that many ladder users attempt to carry objects such as tools, building materials, decorating equipment, etc. up ladders by hand. Such practices frequently cause ladder users only to have at best one hand and one foot in contact with the ladder. It is therefore easy for the ladder to overbalance, or for the ladder user simply to miss his footing and fall off the ladder.

Legislation has recently been introduced throughout the EC requiring ladder users not to carry any objects when ascending or descending a ladder at a place of work. Clearly, there is a strong need for a new design of apparatus the use of which satisfies the legislative requirements.

According to DE-A-1292581, there is provided an apparatus for stacking and destacking items on warehouse shelves. The apparatus includes an upwardly extending framework and a goods hoist including a load supporting means secured in the framework. The goods hoist is moveable vertically and horizontally on the framework, and includes a number of suckers for picking up items from the top of a stack, moving them laterally off the shelving against which the apparatus stands and lowering them to e.g. a run-out conveyor disposed at ground level.

The apparatus of DE-A-1292581 is dedicated to one particular task, and moreover suffers the disadvantage that the goods hoist is for the most part remote from the position at which the operator controls the apparatus. Accordingly, the operator has to employ further means such as a ladder fixed to the framework in order to assess the goods being moved by the goods hoist.

US-A-4199041 discloses a ladder that can be fixed to a bunk bed, by means of hooks that overhang the top rail of the bed. However, the ladder of US-A-4199041 is intended to remain in a fixed position relative to the bed rail when in use, and is simply removable for storage purposes. Accordingly, a user may only access one location by climbing to the top of the ladder disclosed in this document.

US-A-1444759 discloses a library-type ladder to which a height-adjustable platform is slidably secured. However, this apparatus requires a permanent rail to be secured e.g. to library shelves next to which the library ladder is intended to run. Thus it is essential that the

library shelves are firmly secured and of a robust construction; moreover, the ladder itself and the rail on which it is supported are intended only to carry light loads.

5 US-A-5067587 discloses an access platform e.g. for gaining access to street lamps. This apparatus includes two load platforms that are moveable vertically on the apparatus framework, to raise and lower workmen and materials relative to a working location. The apparatus of US-A-5067587 discloses stabiliser means whereby the apparatus is freestanding. However, the stabilisers are such that the lateral locations of the load platforms are fixed once the stabilisers have been actuated. If it is required to reach a position displaced laterally from the load platforms, it is necessary for all operators and materials to be taken off the apparatus, the stabilisers to be disengaged, the apparatus to be wheeled to a new location, the stabilisers to be re-engaged and the operators and materials to be re-loaded onto the load platforms.

20 US-A-4378860 discloses an apparatus including an upwardly extending framework; a moveable hoist for an operator secured in the framework; and a goods hoist including a load supporting means, the operator hoist being moveable horizontally on the framework and the goods hoist being selectively moveable vertically and horizontally on the framework. However, the apparatus is supported by means of cables that are themselves secured to e.g. a rail or girder extending along the top of a wall of a building. Thus the apparatus of US-A-4378860 cannot be used e.g. on buildings that taper inwardly towards their tops; on buildings having overhanging structures beneath the top rail or girder; on unstable or partly completed structures; or indeed on buildings the construction of which has not yet been commenced. The primary purpose of the apparatus of US-A-4378860 is to permit the application of cladding panels to the exterior of steel framed buildings, after the steel frames have been fully completed.

40 Reference is also made to DE-A-3838283 which describes an external facade frame with a lift and a ladder. The frame is modular and consists of horizontal members on which the ladder is moveable. The frame is supported by ground supports and by horizontal supports fixed to the building facade.

45 According to the invention, there is provided an apparatus for escalating comprising

50 an upwardly extending framework;
a moveable hoist for an operator or an upwardly extending ladder secured in the framework; and
a goods hoist including load supporting means, the operator hoist or ladder being selectively moveable horizontally on the framework, and the goods hoist being such that the load supporting means is selectively moveable vertically and horizontally on the framework, characterised by the inclusion of means whereby the framework is supported predominantly

from below its uppermost point.

An advantage of this apparatus is that the goods hoist may be lifted to a desired level on the apparatus for escalating, and a user of the apparatus may climb or be raised unhindered to that level before loading or unloading the goods hoist, in complete safety. The apparatus is useable in a greater range of situations than the prior art devices.

The arrangement of the invention has numerous additional advantages. Firstly, the optional inclusion of a ladder in the apparatus utilises conventional technology which is cheap and easy to manufacture.

Secondly, the securing of an operator hoist or ladder and a goods hoist in a framework means that the apparatus can be built as a discrete item, for easy attachment to a further structure.

Conveniently, the apparatus may include means for securing the framework to a further structure.

This arrangement allows the apparatus to be used, e.g., in conjunction with fixed warehouse shelving.

Preferred embodiments of the invention include means for securing the framework to a ceiling. This feature allows the apparatus to be secured in front of, e.g., unsafe or incomplete structures.

Conveniently, the height and/or the length of the framework are adjustable. These features improve the versatility of the apparatus.

In a particularly preferred embodiment, the goods hoist and the operator hoist or ladder are rigidly interconnected. It has been found to be particularly advantageous for the goods hoist to be moveable with the operator hoist or ladder on the framework.

The framework may preferably include a guide rail or track and the ladder may include means co-operating with the guide rail or track to permit lateral movement of the ladder on the framework. This arrangement has been found to be the most effective for providing lateral movement of the ladder on the framework.

Optionally, the framework may include a guide rail or track and the operator hoist includes means co-operating with the guide rail or track to permit lateral movement of the operator hoist on the framework.

Optionally, the goods hoist may include means for co-operating with the guide rail or track to permit lateral movement of the goods hoist on the framework. This feature is particularly advantageous in some embodiments wherein the goods hoist and the ladder are rigidly interconnected. (It is then desirable to ensure that lateral movements of the hoist and the ladder are coordinated one with the other.)

Optionally, the operator hoist may include an upwardly extending member; an operator platform loosely captive relative to the member; and means whereby the platform may be driven along the member.

In a particularly preferred embodiment, the goods hoist may include an upwardly extending member having a channel therein; a load platform constrained to

move along the member with a part engaged in the channel; and drive means whereby the platform may be driven along the member.

In an alternative embodiment, the upwardly extending member includes a projection adapted to engage a part of the load platform.

In a particularly preferred embodiment, the apparatus comprises a pair of ladders or operator hoists secured on the framework. This allows the apparatus to be highly versatile.

In one optional form of the invention, the ladders or operator hoists are interconnected by e.g. the load supporting platform of a common goods hoist. This version of the invention is particularly suitable for use in warehousing where elongate objects are stored on shelves, since the load supporting means of the goods hoist may be sized adequately to raise and lower such elongate components.

Alternatively, there may be provided a separate goods hoist secured to each ladder or operator hoist.

Conveniently, the apparatus may include a harness secured to the or a ladder or operator hoist, whereby a user of the apparatus may be prevented from falling from the apparatus. Optionally, the goods hoist may be arranged to be inoperative unless the harness is fastened about a user of the apparatus.

These two features advantageously improve the safety of the device in use.

Embodiments are now described by way of example, with reference being made to the accompanying drawings. In the following, Figs 1-3 and 8 illustrate embodiments of the invention, and Figs 4-7 illustrate other informative examples falling outside the scope of the claimed invention. In the drawings:-

Figure 1 is a perspective view of one form of apparatus in accordance with the invention;

Figure 2 is a schematic, perspective view of part of the framework shown in Figure 1;

Figure 3 is an enlarged, perspective view of one of the goods hoists of the apparatus of Figure 1;

Figure 4 is a perspective view of a simple form of another escalating apparatus

Figure 5 is a perspective view of an apparatus specifically adapted for use in decorating operations;

Figure 6 is a perspective view of a variant of the apparatus of Figure 4;

Figure 7 is a perspective view of a variant of the apparatus of Figure 5; and

Figure 8 is a further variant on the embodiment of Figure 4, in which the operator support and load platform are more readily moveable laterally on the apparatus.

Referring to the drawings, there is shown an apparatus 10 for escalating, the apparatus including a pair of goods hoists 20.

The apparatus 10 includes a rectangular framework

11. Framework 11 consists of a series of square or rectangular section members secured to one another in a rectangle. As best shown in Figure 2, the height of the rectangle is adjustable by means of the members 11a (which constitute the upright ends of the rectangle) being adjustable in length. This is achieved by virtue of the members 11a being constituted by pairs of members, one of which is hollow, of differing cross sectional dimensions. The smaller of the two members 11a at each end of the framework 11 is adapted to slide into the larger of the two members in the manner of a telescope. Means may be provided for locking the members 11a to give rise to a desired overall height of the framework.

The members 11b interconnecting the upright members 11a may be adjusted by means of similar mechanisms, whereby the length of the framework 11 may also be adjusted.

In an alternative embodiment (not shown), the feature permitting adjustment of the size of the framework may be dispensed with. Such an embodiment could be manufactured as a bespoke item, according to the requirement of a user thereof.

A pair of ladders 12a, 12b is secured on the framework 11. The ladders 12a, 12b are of conventional design, except that the upper ends 13 of the respective ladder uprights are formed into hook-like projections. The projections 13 hook over the top edge of the upper member 11b. The undersides of the hook-like projections 13 are shaped to be complementary to the upper surface of upper member 11b, whereby the ladders 12a, 12b are retained captive on the framework 11 when the framework 11 is placed in an upright position as shown.

Suitable bearings (such as roller bearings or needle bearings) are in the embodiments shown secured interposed between the undersides of the hook-like projections 13 and the upper surface of upper member 11b. Thus, the ladders 12a, 12b are readily slidable from side to side along the framework upper member 11b. Alternatively or additionally, the bearings may be secured in the upper surface of the member 11b.

The lower ends 14 of the ladder uprights are shaped similarly to the upper ends 13, and hook under the lower surface of the lower member 11b. Bearings (again such as roller or needle bearings) may be secured interposed between the upper surfaces of the hook-like projections 14 and the lower surface of the lower member 11b, whereby the ladders 12a, 12b are retained captive on the framework 11. It will thus be appreciated that the ladders 12a, 12b may freely be moved from side to side on the framework 11. The securing of the ladders 12a, 12b at both the top and bottom ends thereof ensures the ladders are secure and stable on the framework 11.

The ladders 12a, 12b may be removed from the framework simply by sliding them off one or other end thereof. However, if desired, stops may be added e.g. in the form of upwardly and downwardly projecting extensions of the side members 11a, to prevent the ladders from running off the ends of the framework 11. Such

stops may be removable.

Further uprights 21a, 21b are respectively secured in an analogous manner to extend on the framework between the upper and lower members 11b parallel to the uprights of the ladders 12a, 12b and spaced a short distance laterally therefrom.

The further uprights 21a, 21b include guide channels for respective hoist platforms 22a, 22b. The uprights 21a, 21b are in the embodiment shown constrained to move laterally with the respective ladders 12a, 12b with which they are associated. This is achieved by means of respective, rigid interconnections between the respective ladders 12a, 12b and the associated uprights 21a, 21b.

In an alternative embodiment, one or more of the rigid interconnections between the ladders 12a, 12b and the respective uprights 21a, 21b may be dispensed with. This would allow one or both the uprights 21a, 21b and hence the hoist platforms 22a, 22b, to be laterally moveable on the framework 11 independently of the associated ladder 12a, 12b. Thus, one or more of the ladders would be useable in a more conventional manner if desired, without the need to manoeuvre a hoist with the ladder.

Each member 21a, 21b in the embodiment shown includes a channel into which a projecting portion of the respective hoist platform 22a, 22b is engaged, for guidance purposes.

As best shown in Figure 3, the respective uprights 15a, 15b of each ladder 12a, 12b adjacent the corresponding upright 21a, 21b include a channel 16 extending along the length thereof.

An edge 23 of each respective platform 22a, 22b is constrained to move adjacent the associated channel 16, by virtue of a projection on the respective platforms 22a, 22b engaging into the channel 16. Drive means such as chains or belts for the hoist platforms 22a, 22b are disposed within the respective channels 16 in operative engagement with the projections on the respective platforms 22a, 22b. It will thus be appreciated that actuation of one of the drive means either upwardly or downwardly causes upward or downward movement of the hoist platform 22a, 22b connected thereto.

A motor means (not shown) may be provided, whereby the drive means may be actuated automatically. A suitable control switch may also be provided for the motor means.

It will thus be seen that the two hoist platforms 22a, 22b may between them be moved to any position within the rectangular envelope defined by the framework 11. This is achieved by sliding one or other of the ladder plus hoist assemblies as appropriate along the framework as described hereinabove, and selective raising or lowering of the desired platform 22a, 22b until it rests at a suitable height.

As shown in Figure 1, the apparatus is secured by means of suitable fixings (such as bolts, rivets, etc.) to a shelving rack 25. This method of fixing is suitable when

the apparatus is to be used in conjunction with a firmly secured structure, such as wall-secured shelving. The shelving provides a firm mounting for the apparatus.

However, it may be desired to use the apparatus in conjunction with, e.g., unstable shelving or perhaps an incomplete structure. Under such circumstances, the framework 11 may be equipped with jacking feet (not shown) whereby the framework 11 and hence the apparatus as a whole is a freestanding item. Embodiments of this kind are shown in Figures 4 to 8 of the drawings. Additionally, suitable fixing means may be secured to the framework 11 whereby the apparatus may be secured to, e.g., a ceiling or overhead beam; or an adjacent wall. Such means may be in the form of, e.g., angle brackets extending upwardly of the upper member 11b.

The apparatus shown may optionally include a pair of harnesses secured respectively to ladders 12a, 12b. The harnesses would be slidable up and down the respective ladders, and would be suitable for wearing by a user of the apparatus. The purpose of the harnesses would be to prevent users from falling off the apparatus.

It is contemplated that the harnesses would include electrical and/or mechanical interlock means, whereby the hoist platforms 22a, 22b would be rendered immobile unless the harnesses are secured about the users of the apparatus.

In an alternative arrangement, a single harness may be provided, the harness being detachable from one of the ladders 12a, 12b and reattachable to the other ladder 12a, 12b as desired.

Yet a further variant of the invention comprises a pair of ladders such as 12a, 12b having upright members 15a, 15b as shown in Figure 1. However, the pair of platforms 22a, 22b and the corresponding guide uprights 21a, 21b would be dispensed with. Instead, a single hoist platform may be provided interconnecting the uprights 15a, 15b in a vertically slidable manner. This arrangement is particularly suitable when the apparatus is intended for carrying elongate objects such as vehicle exhaust pipes. Obviously, in this embodiment the two ladders 12a, 12b would be simultaneously laterally moveable.

The embodiment shown in Figures 1 to 3 includes guarding 26 extending around three of the four sides of each rectangular platform 22a, 22b. The guarding 26 is open along one edge 23 of each platform for ease of loading of the respective platforms.

The ladder and hoist assemblies are moveable laterally by means of manual propulsion. However, the lateral motion of the assemblies could be motorised if desired. Suitable control means such as switch gear and a power supply could be incorporated.

There may be provided more than the two hoist and ladder assemblies shown in the drawings, especially if the framework 11 is constructed having a long length. For example, many warehouse shelf units are more than 15 metres long. It would be impractical in some cases to attempt to provide rapid access of a hoist and ladder

assemblies to all parts of the frontage of such a shelf unit if only two hoist and ladder assemblies are provided.

In embodiments in which ladders and hoists are laterally moveable independently of one another, a disparate number of ladders and hoists may be provided if desired.

In use of the apparatus, an operator would initially position one of the hoist platforms at an appropriate position for loading or unloading, by sliding one or other of the ladder and hoist assemblies laterally and actuating the drive means for the hoist in question until the platform is at a desired lateral and vertical position. The position of the platform could if necessary be locked by means of an interlock effective on the drive means. The operator would then climb the ladder adjacent the positioned hoist, having first secured himself into the harness if this is a requirement in the installation concerned. Once the operator reaches the height of the platform it is an easy matter for him to load goods from, e.g., a shelf disposed adjacent the platform onto the platform itself.

The operator would then return to floor level or the level of another shelf and operate the hoist to bring the platform to a desired level for unloading. The hoist and ladder assembly could be moved laterally to position the platform as desired.

Clearly, the sequence of operations required to load items from floor level onto shelving would generally be a reverse of the above described procedure.

The apparatus provides a low-cost solution to a common problem in warehouse storage installations. The apparatus is cheaper to fabricate and maintain than, for example, a stacker truck, and moreover may readily be used e.g. in relation to mezzanine level shelving and in conjunction with shelving units spaced apart only by narrow aisles. Such places are generally inaccessible to stacker trucks.

The embodiment described is adjustable in height and length. In such an embodiment, adjustable length ladders 12a, 12b and upright members 21a, 21b may be employed. Alternatively, a range of sizes of ladders and upright members may be available, and the framework 11 adjusted to a height to suit the ladders and uprights chosen.

Many variants on the arrangements described herein may be devised in accordance with the claims. For example, the ladders of the preferred embodiment may be replaced by alternative means such as a flight of steps. Optionally the ladders may be replaced by e.g. further hoists adapted to raise and lower users of the apparatus in safety. One form of such a hoist may be a kind of escalator comprising one or more horizontal rungs constrained and driveable to move vertically in a pair of guide channels formed in a corresponding pair of upright members laterally moveably secured on the framework. A suitable safety harness may be provided in conjunction with the rung(s) to ensure that a user stepping onto the rung(s) does not run the risk of falling off the apparatus during movement of the rung(s).

When the apparatus includes an operator hoist, such a hoist may, for example, be configured similarly to the hoist shown in Figure 3 of the drawings, i.e. a hoist platform vertically moveable on an upwardly extending guide channel itself moveable from side to side on the framework.

A suitable method for the construction of the apparatus is by fabrication (e.g. by welding, riveting and screwing) from e.g., mild steel. However, various other materials could be used. For example, lightweight alloy metals could be used in certain installations. There may also be a requirement to minimise the risk of explosion in certain environments. The apparatus could then be manufactured from or coated with a material which is unlikely to cause sparking. When the apparatus is to be used in areas of high flammability, and in certain other applications, the drive to the hoist platforms is preferably either manual or hydraulic. The use of such drives is not precluded in non-flammable applications.

Referring to Figure 4, there is shown an apparatus indicated generally by the reference numeral 10 including three upwardly extending frame members 11a, 11b, 11c. The frame members 11a, 11b, 11c extend generally vertically in use of the apparatus, and are generally parallel one to another. The frame members 11a, 11b, 11c are equi-spaced and interconnected at their upper and lower ends by horizontal frame members 12a and 12b.

Thus, the frame members 11 and 12 between them define a generally upwardly extending rectangular framework, which is divided into two parallel, generally upwardly extending rectangular planes or regions 13a, 13b which are adjacent one another.

Extending rearwardly of the apparatus when aligned as shown in Figure 4 are respective bracing members 14a, 14b. The bracing members 14a, 14b are rigidly secured respectively at the lowermost ends of the outermost, upwardly extending frame members 11a, 11c. Respective struts 16a, 16b extend between the approximate mid points of the upwardly extending members 11a, 11c and positions generally adjacent the free ends of the corresponding bracing members 14a, 14b to ensure that the fixing of the bracing members 14a, 14b relative to the upwardly extending frame members 11a, 11c is rigid. For example, the fixing can be achieved by means of bolts, snap lock connections and/or welds.

Additionally, cross-bracing members 17 rigidly interconnect the opposite corners of the rectangular base portion of the apparatus defined by the bracing members 14a, 14b and the lower horizontal member 12b. Thus, the framework of the apparatus is simple yet rigid.

The edges of the frame members 11b, 11c which face into the rectangular plane 13b are provided with channels. The channels are not visible in the figures, but may be of a design similar to those shown in Figure 3. The channels are adapted slidably to receive complementary projections formed on the corners of an operator support platform 18 adjacent the channels. The operator support platform 18 is a horizontal planar mem-

ber, and it is retained loosely captive in the channels in the members 11b, 11c. Therefore, the operator support platform 18 is constrained to move in a generally vertical direction.

Means (not shown) may be provided whereby the support platform 18 may be raised and lowered. For example, chain drives may be incorporated in one or more of the channels in driving engagement with the platform 18. The chains of the chain drives could be operated manually (for example if a gear wheel having a handle is provided), or by means of a suitable motor.

Alternatively, a gravity counterbalance mechanism could be employed, wherein the platform 18 is supported on cables running e.g., within the channels and a counterbalance weight may be provided elsewhere on the apparatus in the manner of an elevator.

A further possibility of the employment of, e.g., a spring drive to drive the platform 18 upwardly and/or downwardly within the rectangular plane 13b as desired.

It is also desirable to ensure that the platform 18 remains horizontal during its travel. This may be achieved, for example, by the use of drive members (such as springs, cables or chains) which are functionally linked for simultaneous, identical movement. This can be achieved, for example, by passing the chains or cables over a common gear wheel or pulley, or over pulleys or gear wheels the motions of which are synchronised.

In the embodiment shown, the platform 18 is braced on its lower edges by respective fillets 19 which define downwardly extending edges of the rearmost corners of the platform. Other forms of stiffening and strengthening mechanisms may be employed instead.

The platform 18 is shown protruding forwardly of the apparatus. However, the arrangement is such that even in such an embodiment the centre of mass of an operator 20 acts within the "footprint" of the apparatus defined by the members 14a, 14b and 12b. Thus, the apparatus is inherently stable in use. Further stability can be provided in embodiments in which the operator platform 18 extends rearwardly, within the "footprint" referred to.

A load platform 22 of similar construction to the operator platform 18 is moveable vertically and horizontally in the rectangular plane 13a adjacent the plane 13b. The means whereby the platform 22 may be supported and driven vertically are similar to those described in relation to the operator platform 18. In the embodiment of Figure 4, the load platform 22 differs from the operator platform 18 in that a guard rail 23 is provided extending about a plane disposed a short distance above the upper surface of the platform 22. The guard rail 23 prevents objects placed on the platform 22 from falling off. Instead of a guard rail, the platform 22 may be provided with e.g. one or more lips or side walls (which may optionally take the form of a closeable box), to achieve the same purpose.

Horizontal movement of the load platform 22 broad-

ly within plane 13a may be achieved eg. by virtue of the platform being loosely captive in the fillets 22a that engage the upwardly extending members 11a and 11b. For example, the fillets may each include upstanding projections that engage a slot of complementary profile and formed in the base of platform 22.

When one or other of the platforms 18, 22 is driven by a motor means, it is desirable for the motor controls to be accessible to the operator 20 while he is standing on the platform 18. Therefore, some embodiments of the invention may include, e.g., push button controls connected to the motor controlled circuitry by means of appropriate cables. The push button unit may be secured either temporarily or permanently on one of the frame members of the apparatus at an appropriate height, by means of e.g., suitable hanging hooks; or the push button unit may be intended to be hand held by the operator 20 during use of the apparatus.

The two platforms 18, 22 may be linked together such that their movement is synchronised, or simultaneous. Indeed, the two load platforms 18, 22 may be rigidly linked together so that only a single drive means is required to drive both platforms. In such a case, it is likely that the load platform 22 would be secured at a height above that of the platform 18 to facilitate access by the operator 20 to the objects carried on the platform 22. In such an embodiment, lateral movement of the operator platform may be necessary. This may be achieved e.g. by the means disclosed above in relation to platform 22.

The embodiment of Figure 4 is supported on floor or ground engaging wheels or castors 24. Thus, the apparatus may readily be wheeled into position for use and wheeled away again after use. The castors 24 may desirably be fitted with brakes to lock the apparatus in position during use.

Similarly, locking means, such as locking pins insertable into the frame members or brakes operable on the drive means for the platforms, are desirably provided to secure the platforms 18 and 22 in position during use of the apparatus.

Referring now to Figure 5, there is shown a further embodiment of the apparatus which additionally includes various features to enable the specific use of the apparatus for the hanging of wallpaper and carrying out decorating operations. The embodiment of Figure 5 is broadly similar to that of Figure 4, and therefore components of the embodiment of Figure 5 corresponding to the components of the Figure 4 embodiment will be defined herein using identical reference numerals.

The embodiment of Figure 5 includes four generally upwardly extending frame members 11a, 11b, 11c and 11d. The frame members 11 are generally parallel one to another and equi-spaced, thereby to define three rectangular planes 13a, 13b and 13c.

The operator platform 18 is constrained to move in the central plane 13c, in the manner described in relation to the Figure 4 embodiment. Platform 18 of the Fig-

ure 5 embodiment additionally includes a guard rail 25 which in the embodiment shown is open towards the left hand edge of the platform 18. The guard rail 25 extends about a zone which would correspond to the waist height of a typical operator of the apparatus, thereby improving the safety of the apparatus for operators. The open side of the guarding 25 is intended to allow ready access to the platform 18 by operators. For this reason, the platform 18 is moveable in the central plane 13c, so that there is space adjacent the plane 13a for an operator safely to step onto and off the platform 18.

In the embodiment of Figure 5, the load support platform 22 is rigidly secured to the operator platform 18, e.g., by welding at the top of the guard rail 25 and by means of additional struts 27 which extend downwardly from the underside of the load support platform 22 towards the downwardly extending members 25a disposed on the right hand side of the guard rail 25.

The load support platform 22 and the struts can if desired be constructed so that the load platform 22 hinges or folds to adopt a parking position, e.g. vertically aligned adjacent the members 25a, when not in use. Suitable hinges, joints and fastening means may be provided for this purpose.

In the embodiment of Figure 5, an optional feature is the positioning of the push button controls of a motor adapted to drive the platforms 18 and 22 at the location indicated by the reference numeral 28.

A pair 29a, 29b of support members extends forwardly of the apparatus from the region above the platform 18, in the region 13c. The members 29a, 29b are constrained in the channels of the frame members 11b, 11d to move vertically on the apparatus in a manner similar to the platform 18. Gripped rotatably between the members 29a, 29b may be a roll of wallpaper 30. The wallpaper roll 30 may optionally be supported on a roller rotatably secured between the support members 29a, 29b; alternatively, the support members 29a, 29b may simply include further members e.g. spigots at the free ends thereof at right angles to the support members 29a, 29b which further members protrude into the open ends of the wallpaper roll 30, thereby rotatably to support it. Another possibility is to provide a single support member such as member 29a having secured to its free end a horizontal bar on which e.g. a wallpaper roll may be hung.

The arrangement may be such that movement of the support members 29a, 29b is independent of the movement of the platform 18; alternatively, the movement of the support members 29a and 29b may be arranged by means of suitable support means to be synchronous with the platforms 18 and 22 in the embodiments shown. Of course, in order to maintain the wallpaper roll 30 horizontal, it is essential in this embodiment that the movements of the respective support members 29a and 29b are synchronised one with another.

Extending forwardly of the apparatus at the uppermost edge thereof is a pair 31a, 31b of arms which are

interconnected at their free ends by a padded, horizontal presser or gripper member 33.

It will be appreciated that in use of the apparatus during the hanging of wallpaper, it would be a simple matter for an operator of the apparatus to unroll a length of wallpaper above the roll 30 thereof and trap it between the presser bar 33 and a wall to which the wallpaper is to be adhered. Assuming that the wall and/or the wallpaper had previously been pasted with a suitable adhesive wallpaper paste, the roll 30 could then be moved downwardly on the support members 29a, 29b in channels formed in the members 11b and 11d, thereby to unroll further wallpaper which would then adhere smoothly to the wall in a straight line.

The embodiment of Figure 5 includes a number of additional features which particularly suit it for use in decorating operations.

In particular, the embodiment includes hooks 34 attached to the support platform 22, whereby, e.g. paint brushes and paint rollers may be hung up in such a position as to avoid damaging a newly decorated wall adjacent the apparatus.

Furthermore, the members 14a, 14b, 16a and 16b are secured to the upwardly extending frame members 11a and 11c by means of suitable hinges 35 secured at the attachment points. Thus, the pair of wings defined respectively by the members 14a and 16a and 14b and 16b may be folded inwardly to reduce the overall size of the apparatus during carrying thereof.

Figure 5 shows a power cable 36 whereby power may be delivered to the apparatus to power the platforms when the apparatus is designed to be powered by an electric motor. The power cable 36 may optionally be connected to mains power (via a transformer if necessary) or to a battery pack.

The apparatus is typically manufactured from extruded aluminium sections, which may be secured together, e.g. by welding. Various other materials may also be employed. For example, the apparatus may be manufactured from any of a number of steels or other metals, from plastics materials or even from timber. Moreover, any of the materials employed may be coated with, e.g., a plastics or rubberised finish for safety and durability. The platforms 18, 22 may be coated with non-slip materials for added safety.

The embodiment of Figure 5 employs adjustable feet 37 to support the bracing members 14a, 14b and, if desired, the lowermost extremities of the upright members 11. The feet 37 are adjustable, to level the apparatus and to adjust its overall height. Instead of or in addition to feet the apparatus may include e.g. anchor means such as adjustable knives which are adapted to engage the ground when the apparatus is used outdoors.

The arms 31a, 31b protrude forwardly of the apparatus further than the support members 29a, 29b. Thus, there is adequate space for the mounting of a full roll of wallpaper 30 on the apparatus without it fouling a wall

against which the presser member 33 is pressing a length of wallpaper. Moreover, the positioning of the roll 30 closer to the apparatus than the free end thereof causes the wallpaper to adopt a parabolic curve which may easily be smoothed onto a wall to provide a good decorating result.

Referring now to Figure 6, there is shown a further design, which is a variant on the embodiment of Figure 4. In Figure 6 there are provided four bracing members 14 extending perpendicular to the lower ends of the frame members 11. A pair of bracing members extend respectively from each member 11. Struts 16 extend between the bracing members 14 and the members 11. The members of the pairs of bracing members extend on opposite sides of the apparatus, to create a stable base for the apparatus regardless of the direction in which forces may be applied to the frame members. Thus, the embodiment of Figure 6 may be used e.g. in the middle of a room, for instance to allow the changing of light bulbs or ceiling tiles.

The embodiment of Figure 6 may be regarded as a version of the Figure 4 embodiment to which an additional set of bracing members 14 and struts 16 has been secured, to enlarge the base area of the apparatus and spread the feet and/or wheels of the apparatus for greater stability. The additional members 14 and the struts 16 may be attached by e.g. welding, to create a permanently enlarged base.

Alternatively, the additional members may be attached by releasable means such as bolts or spring clips.

Yet a further possibility is to allow the members 14 and struts 16 to be lockably moveable on the apparatus. For example the attachment of the proximal ends of the members 14 and struts 16 may be achieved by engagement of the projections on the members in complementary slots or tracks in the upwardly extending members 11. This would allow movement of the members forming the base of the apparatus in the directions shown by the arrows A, A'. The members forming the base can be moveable over a substantial portion of the length of the members 11 if desired. Thus, the apparatus may be safely used in places where the floor height changes abruptly, such as on stairs or in swimming pools.

As an alternative or in addition to the foregoing arrangements, the connection between the bracing members 14 and the members 11 may be pivotable to allow rotation of the members 14 in the directions shown by the arrows B. If this arrangement is adopted, further, pivotable connections must be provided at the ends of the struts 16. The changes in the lengths of the struts 16 can be accommodated by ensuring that the struts 16 are telescopically collapsible, or by allowing the upper end of each strut to slide relative to the relevant member 11 as indicated by the arrows A'. Thus, the apparatus may safely be used on, e.g. sloping or uneven ground.

Suitable joint and/or locking means for the various members may be provided in conjunction one with an-

other.

The Figure 6 embodiment also shows a further optional feature, in the form of safety guarding 40 disposed on the forward edge of the operator support platform. The guarding may extend to a predetermined height above the platform, e.g. to waist height as shown, or to the full height of an operator. The purposes of the guarding are to prevent an operator from falling from the apparatus, and also to minimise the risk of an operator trapping e.g. a hand or a foot when travelling on the platform.

The guarding 40 may be moveable relative to the platform, to allow the operator access to a workpiece. The guarding can be arranged to be slidable upwardly, downwardly or sideways relative to the platform for this purpose. Alternatively, the guarding 40 can be manufactured as a flexible item so that it may be retracted by rolling it onto a roller (not shown). A suitable interlock means can optionally be provided to prevent the guarding from moving relative to the operator platform 18 while the platform 18 is moving. Further guarding similar to guarding 40 may additionally or alternatively be provided adjacent the rear edge of platform 18 if desired.

Referring now to Figure 7, there is shown a version of the Figure 5 embodiment, to which the additional bracing members and struts shown in Figure 6 have been secured. An additional, optional feature of the Figure 7 embodiment is a trough 41 which is releasably securable by means of, e.g. hooks or spring clips on the apparatus. The trough 41 may conveniently be sited a short distance below the roll 30 of wallpaper, and may contain water or wallpaper adhesive to facilitate the hanging of wallpaper.

While the embodiments show the rectangular planes 13a, 13b and (where present) 13c as being coplanar one with another, it will be appreciated that this need not be so and the planes 13 may be angled one relative to another. Alternatively, the planes 13 may be parallel but not co-planar.

The embodiment of Figure 8 is similar to that of Figures 4 to 7 except that a greater degree of lateral movement of the operator and load supporting components is possible, by means of an arrangement like that shown eg. in Figure 1. In the Figure 8 embodiment, the operator support is in the form of a ladder, but may equally well be a hoist-like platform or a ladder vertically moveable on the framework. Such means are also, horizontally moveable thereon.

The apparatus of any of the embodiments disclosed herein may be constructed as a permanently erected item; as a potentially dismantlable or foldable item or as a kit of parts and/or members which may be assembled to form the apparatus. Suitable joints and/or fixings may be incorporated to facilitate dismantling and reassembly.

Furthermore, any of the optional features of one of the embodiments described herein may equally readily be applied to any other embodiment if desired, as de-

scribed in the appended claims.

It will be appreciated that the apparatus of the invention can be manufactured as an extremely versatile item, which is suitable for use, e.g., by professional builders, carpenters, electricians, engineers, decorators, DIY enthusiasts and numerous other operators who would otherwise be required to carry objects by hand up a ladder to gain access to their work.

Moreover, it is possible to arrange several examples of embodiments of the invention to work in conjunction with one another. For example, several examples of the embodiments of Figures 1 or 8 may be placed with their ends abutting or adjacent but spaced from one another, to form parallelogram-shaped structures that may be used to surround e.g. buildings, construction sites and shelving units. If the ends of the apparatuses are in abutting relationships, it would be desirable to provide releasable locking means such as quick release bolts for securing the apparatuses together as a rigid structure.

Alternatively or additionally examples of the apparatus may be secured one above another to permit access to tall structures.

When plural examples of the apparatus are secured adjacent one another, it may be advantageous to provide adapter members whereby the laterally and vertically extending members (on which the various components are moveable) may be appropriately interconnected, thereby to allow e.g. access of a load or operator platform to all points of a structure constituted by or including the apparatus.

Structures in which examples of the apparatus are secured one above another may be adapted to receive the load or operator platforms in a removeable manner, so that such platforms may selectively be fed into the structure at the bottom for subsequent movement elsewhere on the apparatus.

40 Claims

1. An apparatus for escalating comprising

an upwardly extending framework (11);
 a moveable hoist (18) for an operator or an upwardly extending ladder (12) secured in the framework; and
 a goods hoist (22) including load supporting means, the operator hoist (18) or ladder (12) being selectively moveable horizontally on the framework (11), and the goods hoist (22) being such that the load supporting means is selectively moveable vertically and horizontally on the framework (11), characterised by the inclusion of means whereby the framework is supported predominantly from below its uppermost point.

2. An apparatus according to Claim 1 including means for securing the framework to a further structure.
3. An apparatus according to Claim 1 or Claim 2 including means for securing the framework to a ceiling.
4. An apparatus according to any of Claims 1 to 3 including means (11a) whereby the height of the framework is adjustable.
5. An apparatus according to any of preceding claim including means whereby the length of the framework is adjustable.
6. An apparatus according to any preceding claim wherein the hoist (22) and the ladder (12) or operator hoist (18) are rigidly interconnected.
7. An apparatus according to any preceding claim wherein the framework includes a guide rail or track (11a) and the ladder includes means (13;14) co-operating with the guide rail or track to permit lateral movement of the ladder on the framework.
8. An apparatus according to any of Claims 1 to 6 wherein the framework includes a guide rail or track (11a) and the operator hoist includes means co-operating with the guide rail or track to permit lateral movement of the operator hoist on the framework.
9. An apparatus according to any preceding claim wherein the framework includes a guide rail or track (11a) and the goods hoist includes means (13) co-operating with the guide rail or track to permit lateral movement of the goods hoist on the framework.
10. An apparatus according to any preceding claim wherein the operator hoist includes an upwardly extending member; an operator platform (18) loosely captive relative to the member; and means whereby the platform may be driven along the member.
11. An apparatus according to any preceding claim wherein the goods hoist includes an upwardly extending member (12a) having a channel (15a) formed therein; a load platform (23) constrained to move along the member with a part engaged in the channel; and drive means whereby the platform may be driven along the member.
12. An apparatus according to Claim 11 modified in that the upwardly extending member includes a projection instead of or in addition to the channel and the load platform includes means adapted to receive the projection.
13. An apparatus according to any preceding claim comprising a pair of ladders (12a, 12b) or operator hoists secured on the framework.
14. An apparatus according to Claim 13 wherein the ladders or operator hoists are interconnected by a common goods hoist.
15. An apparatus according to Claim 13 including a separate goods hoist (22a, 22b) secured to each ladder or operator hoist.
16. Apparatus according to any preceding claim wherein the or a ladder or operator hoist secured on the framework is moveable independently of any goods hoist secured on the framework.
17. An apparatus according to any preceding claim including a harness (20) secured to the or a ladder or operator hoist, whereby a user of the apparatus may be prevented from falling from the apparatus.
18. An apparatus according to Claim 17 including means whereby the goods hoist is inoperative unless the harness is fastened about a user of the apparatus.
19. Apparatus according to any preceding claim, wherein the load supporting means of the goods hoist is positioned to one side of the operator hoist or ladder, such that the load supporting means does not obstruct the space in front of the operator hoist or ladder.
20. A shelving access system comprising an escalating apparatus as defined in any preceding claim.
21. A system comprising a shelving unit, and an escalating apparatus for accessing the shelving unit, the escalating apparatus comprising apparatus defined in any of claims 1 to 19.

Patentansprüche

1. Vorrichtung zum Hochsteigen, umfassend:
- ein sich nach oben erstreckendes Rahmengerüst (11),
eine bewegliche Hebevorrichtung (18) für eine Bedienungsperson oder eine im Rahmengerüst befestigte, sich nach oben erstreckende Leiter (12), und
eine Materialhebevorrichtung (22) mit einer Lasttrageeinrichtung, wobei die Personenhebevorrichtung (18) oder die Leiter (12) wahlweise horizontal am Rahmengerüst (11) bewegbar ist und die Materialhebevorrichtung (22) so (ausgestaltet) ist, daß die Lasttrageeinrichtung

- wahlweise vertikal und horizontal am Rahmengerüst (11) bewegbar ist, dadurch gekennzeichnet, daß Mittel vorgesehen sind, durch welche das Rahmengerüst vorwiegend unterhalb seines höchsten Punktes getragen bzw. gestützt ist. 5
2. Vorrichtung nach Anspruch 1 mit einer Einrichtung zum Befestigen des Rahmengerüsts an einer weiteren Struktur. 10
3. Vorrichtung nach Anspruch 1 oder 2 mit einer Einrichtung zum Befestigen des Rahmengerüsts an einer Decke. 15
4. Vorrichtung nach einem der Ansprüche 1 bis 3 mit einer Einrichtung (11a), durch welche die Höhe des Rahmengerüsts einstellbar ist.
5. Vorrichtung nach einem der vorangehenden Ansprüche mit einer Einrichtung, durch welche die Länge des Rahmengerüsts einstellbar ist. 20
6. Vorrichtung nach einem der vorangehenden Ansprüche, wobei die Hebevorrichtung (22) mit der Leiter (12) oder der Personenhebevorrichtung (18) starr verbunden ist. 25
7. Vorrichtung nach einem der vorangehenden Ansprüche, wobei das Rahmengerüst eine Führungsschiene bzw. Gleitbahn (11a) und die Leiter eine mit der Führungsschiene bzw. Gleitbahn zusammenwirkende Einrichtung (13,14) umfaßt, um eine Seitwärtsbewegung der Leiter am Rahmengerüst zu gestatten. 30
8. Vorrichtung nach einem der Ansprüche 1 bis 6, wobei das Rahmengerüst eine Führungsschiene bzw. Gleitbahn (11a) und die Personenhebevorrichtung eine mit der Führungsschiene bzw. Gleitbahn zusammenwirkende Einrichtung umfaßt, um eine Seitwärtsbewegung der Personenhebevorrichtung am Rahmengerüst zu gestatten. 35
9. Vorrichtung nach einem der vorangehenden Ansprüche, wobei das Rahmengerüst eine Führungsschiene bzw. Gleitbahn (11a) und die Materialhebevorrichtung eine mit der Führungsschiene bzw. Gleitbahn zusammenwirkende Einrichtung (13) umfaßt, um eine Seitwärtsbewegung der Materialhebevorrichtung am Rahmengerüst zu gestatten. 40
10. Vorrichtung nach einem der vorangehenden Ansprüche, wobei die Personenhebevorrichtung ein sich nach oben erstreckendes Element, eine lose an dem Element gesicherte Personenplattform (18) sowie eine Einrichtung umfaßt, durch welche die Plattform längs des Elements gefahren werden kann. 45
11. Vorrichtung nach einem der vorangehenden Ansprüche, wobei die Materialhebevorrichtung ein sich nach oben erstreckendes Element (12a) mit einem darin ausgebildeten Kanal (15a), eine längs des Elements zwangsschlüssig bewegliche Lastplattform (23) mit einem mit dem Kanal in Eingriff stehenden Teil, sowie eine Antriebseinrichtung umfaßt, durch welche die Plattform längs des Elements gefahren werden kann. 50
12. Vorrichtung nach Anspruch 11 mit der Abwandlung, daß das sich nach oben erstreckende Element statt des Kanals oder zusätzlich zu diesem einen Vorsprung aufweist, und die Lastplattform eine Einrichtung zum Aufnehmen des Vorsprungs umfaßt.
13. Vorrichtung nach einem der vorangehenden Ansprüche mit einem Paar am Rahmengerüst befestigter Leitern (12a,12b) oder Personenhebevorrichtungen.
14. Vorrichtung nach Anspruch 13, wobei die Leitern bzw. die Personenhebevorrichtungen durch eine gemeinsame Materialhebevorrichtung miteinander verbunden sind.
15. Vorrichtung nach Anspruch 13 mit einer an jeder Leiter bzw. Personenhebevorrichtung befestigten, separaten Materialhebevorrichtung (22a, 22b).
16. Vorrichtung nach einem der vorangehenden Ansprüche, wobei die oder eine am Rahmengerüst befestigte Leiter bzw. Personenhebevorrichtung unabhängig von einer etwaigen, am Rahmengerüst befestigten Materialhebevorrichtung bewegbar ist.
17. Vorrichtung nach einem der vorangehenden Ansprüche mit einem an der odereiner Leiter bzw. Personenhebevorrichtung befestigten Sicherungsgurt (20), wodurch verhindert wird, daß ein Benutzer der Vorrichtung aus der Vorrichtung stürzt.
18. Vorrichtung nach Anspruch 17 mit einer Einrichtung, durch welche die Personenhebevorrichtung außer Betrieb gesetzt ist, solange der Sicherungsgurt nicht um einen Benutzer der Vorrichtung gelegt ist.
19. Vorrichtung nach einem der vorangehenden Ansprüche, wobei die Lasttrageeinrichtung der Materialhebevorrichtung an einer Seite der Personenhebevorrichtung bzw. der Leiter positioniert ist, so daß die Lasttrageeinrichtung den Raum vor der Personenhebevorrichtung bzw. vor der Leiter nicht verstellt. 55

20. Regalzugriffssystem mit einer in einem der vorangehenden Ansprüche definierten Vorrichtung zum Hochsteigen.
21. System mit einer Regaleinheit und einer Vorrichtung zum Hochsteigen zum Zugriff auf die Regaleinheit, wobei die Vorrichtung zum Hochsteigen eine in einem der Ansprüche 1 bis 19 definierte Vorrichtung umfaßt.

Revendications

1. Un dispositif servant à grimper, comprenant :

un châssis (11) s'étendant vers le haut; un élévateur mobile (18) pour un opérateur, ou bien une échelle (12) s'étendant vers le haut, fixé dans le châssis; et un élévateur à objets (22) comprenant des moyens de support de charge, l'élévateur à opérateur (18) ou l'échelle (12) étant déplaçable sélectivement horizontalement sur le châssis (11), et l'élévateur à objets (22) étant tel que les moyens de support de charge sont sélectivement déplaçables verticalement et horizontalement sur le châssis (11), caractérisé par le fait de comprendre des moyens de manière que le châssis soit supporté de façon prédominante par le dessous de son point le plus élevé.

2. Un dispositif selon la revendication 1, comprenant des moyens pour fixer le châssis à une structure supplémentaire.
3. Un dispositif selon la revendication 1 ou 2, comprenant des moyens de fixation du châssis à un plafond.
4. Un dispositif selon l'une quelconque des revendications 1 à 3, comprenant des moyens (11a) conçus de manière à pouvoir ajuster la hauteur du châssis.
5. Un dispositif selon l'une quelconque des revendications précédentes, comprenant des moyens conçus de manière à permettre d'ajuster la longueur du châssis.
6. Un dispositif selon l'une quelconque des revendications précédentes, dans lequel l'élévateur (22) et l'échelle (12) ou l'élévateur à opérateur (18) sont interconnectés rigidement.
7. Un dispositif selon l'une quelconque des revendications précédentes, dans lequel le châssis comprend un rail ou piste de guidage (11a) et l'échelle comprend des moyens (13; 14) coopérant avec le rail ou piste de guidage, pour permettre un dépla-

cement latéral de l'échelle sur le châssis.

8. Un dispositif selon l'une quelconque des revendications 1 à 6, dans lequel le châssis comprend un rail ou piste de guidage (11a) et l'élévateur à opérateur comprend des moyens qui coopèrent avec le rail ou piste de guidage, afin de permettre un déplacement latéral de l'élévateur à opérateur sur le châssis.
9. Un dispositif selon l'une quelconque des revendications précédentes, dans lequel le châssis comprend un rail ou piste de guidage (11a) et l'élévateur à objets comprend des moyens (13) qui coopèrent avec le rail ou piste de guidage, pour permettre un déplacement latéral de l'élévateur à objets sur le châssis.
10. Un dispositif selon l'une quelconque des revendications précédentes, dans lequel l'élévateur à opérateur comprend un organe s'étendant vers le haut; une plate-forme pour opérateur (18) qui est captive de façon lâche par rapport à l'organe; et des moyens conçus de manière à permettre à la plate-forme d'être entraînée sur l'organe.
11. Un dispositif selon l'une quelconque des revendications précédentes, dans lequel l'élévateur à objets comprend un organe s'étendant vers le haut (12a) ayant un canal (15a) formé en son sein; une plate-forme de chargement (23) contrainte de se déplacer sur l'organe, une partie étant engagée dans le canal; et des moyens d'entraînement, de manière que la plate-forme puisse être entraînée sur l'organe.
12. Un dispositif selon la revendication 11, modifié de manière que l'organe s'étendant vers le haut comprenne une saillie au lieu, ou en plus du canal, et la plate-forme de chargement comprenne des moyens adaptés pour recevoir la saillie.
13. Un dispositif selon l'une quelconque des revendications précédentes, comprenant une paire d'échelles (12, 12b) ou d'élévateurs à opérateur, fixés sur le châssis.
14. Un dispositif selon la revendication 13, dans lequel les échelles ou les élévateurs à opérateur sont interconnectés à l'aide d'un élévateur à objets commun.
15. Un dispositif selon la revendication 13, comprenant un élévateur à objets (22a, 22b) séparé, fixé à chaque échelle ou à chaque élévateur à opérateur.
16. Un dispositif selon l'une quelconque des revendications précédentes, dans lequel la ou une échelle, ou le ou un élévateur à opérateur fixé au châssis

est déplaçable indépendamment de tout élévateur à objets fixé au châssis.

17. Un dispositif selon l'une quelconque des revendications précédentes, comprenant un harnais (20) fixé à la ou à une échelle, ou à l'élévateur ou à un élévateur à opérateur, de manière qu'un utilisateur du dispositif puisse être empêché de tomber de ce dispositif.
18. Un dispositif selon la revendication 17, comprenant des moyens de manière que l'élévateur à objets soit non opérationnel, sauf si le harnais est fixé autour d'un utilisateur du dispositif.
19. Dispositif selon l'une quelconque des revendications précédentes, dans lequel les moyens de support de charge de l'élévateur à objets sont positionnés d'un côté de l'élévateur à objets ou de l'échelle, de manière que les moyens de support de charge n'obstruent pas l'espace à l'avant de l'élévateur à opérateur ou de l'échelle.
20. Un système d'accès à un rayonnage, comprenant un dispositif pour grimper selon l'une quelconque des revendications précédentes.
21. Un système comprenant une unité à rayonnage, et un dispositif pour grimper conçu pour accéder à l'unité à rayonnage, le dispositif pour grimper comprenant les éléments définis à l'une quelconque des revendications 1 à 19.

5

10

15

20

25

30

35

40

45

50

55

FIG. 1

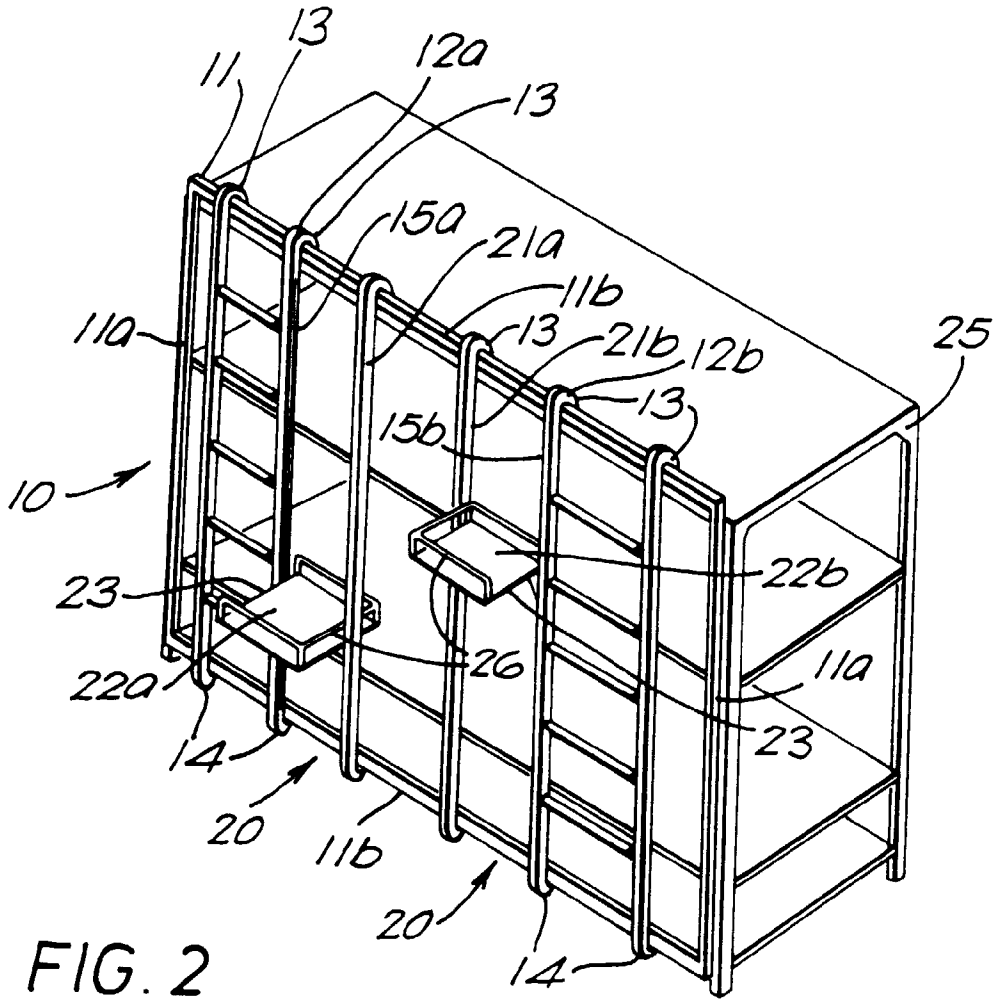

FIG. 2

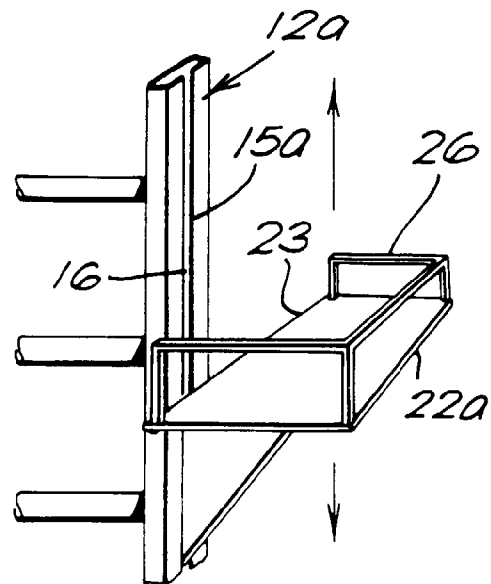
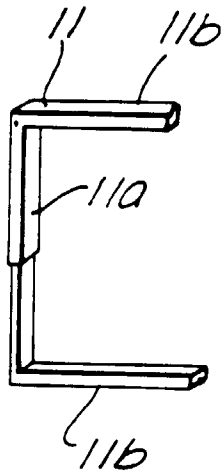

FIG. 3

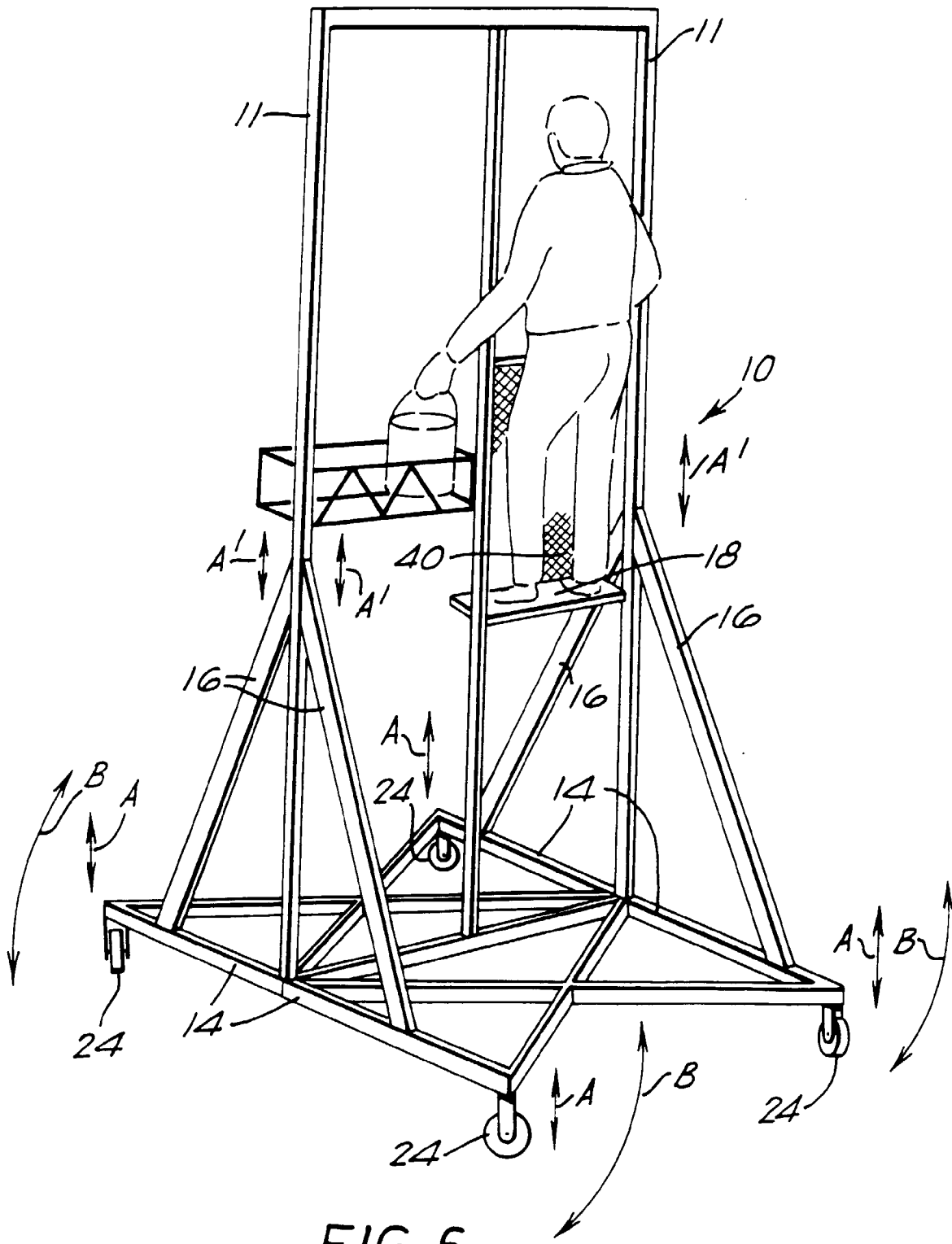

FIG. 6

