



EUROPEAN PATENT APPLICATION

Application number : **95500084.9**

Int. Cl.⁶ : **B63B 35/28, B65D 88/78**

Date of filing : **13.06.95**

Priority : **16.06.94 ES 9401314**

Inventor : **Font Llines, Antonio**
11, calle Iluro
E-08302 Mataro (ES)

Date of publication of application :
20.12.95 Bulletin 95/51

Representative : **SUGRANES - VERDONCES -**
FERREGÜELA
Calle Provenza, 304
E-08008 Barcelona (ES)

Designated Contracting States :
ES FR GR IT NL PT

Applicant : **Font Llines, Antonio**
11, calle Iluro
E-08302 Mataro (ES)

Flexible container for the transportation of drinking water by sea

A new flexible container is described, of spindle (1) shape, for the maritime transportation of drinking water by towing (3) of same by a tugboat (2).

The container has longitudinal reinforcement members (8) and an emptying and filling tube (5), provided with orifices (7), which runs along the full length of the bottom of the container and emerges at its mouths (6) for connection to two systems of valves situated on two floating platforms (4).

At the mouths of the container (6) are fitted two linkage cylinders (16) on which are secured the ends of the walls of the container, the ends of the reinforcement members (8) and the tug guide cable (3).

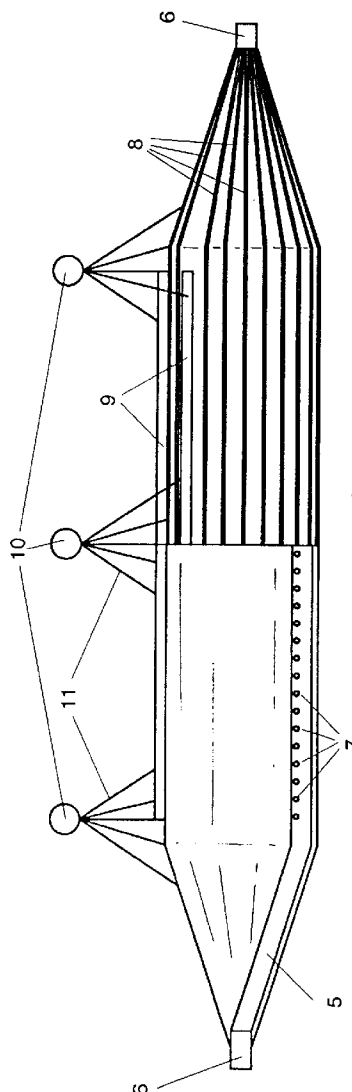

Fig. 2

Field of the technique

The present invention relates to a flexible container, of spindle shape, useful for maritime transportation of drinking water to zones with occasional or permanent shortfalls of water, by means of dragging or towing by a vessel.

State of the technique

Occasional or permanent periods of drought and the lack of suitable aquifers mean that large zones of the planet suffer from a shortage of drinking water, with the attendant problems for the population and for the industrial and agricultural activities of those zones. On the other hand, in other more favoured zones there exist major surpluses of water which are not used and could serve to supply the needs of the zones with shortages, as long as the problem of transportation is solved in an effective and economically acceptable manner, since the alternative solutions, such as the installation of plants to make sea water drinkable, often find poor application due to their cost, to the fact that they cannot be built exclusively to solve occasional problems and that the design and construction of such plants takes a long time, which restricts the capacity to respond to severe problems requiring a quick solution.

The use of tanker ships such as those used in the transportation of crude oil is not very practical for resolving the problem of transportation of drinking water by sea, for the price of transportation using such ships, with very high freight charges, does not correspond with the intrinsic value of the water. Because of this, systems have been developed based on towing of the water to be transported by craft with much more affordable freight charges.

Thus, German patents DE-C-3315744 and DE-C-3412707 describe transportation of large blocks of floating ice (icebergs) protected with flexible covers of plastic materials from Arctic or Antarctic zones to tropical zones, by means of towing by craft. Also known in the art, through patent application PCT W08706212, is the use of flexible plastic containers for storing drinking water in the sea, without the purpose of transporting said water.

Furthermore, North American patent US-5010837 describes a system of transportation of drinking water by sea consisting in tanks of variable shape, with flexible plastic walls, which can be towed by a vessel or can be self-propelling. In all cases, the shapes proposed resemble the hull of a ship, with a float placed by way of a deck line which keeps the tank permanently afloat. The proposed tanks nevertheless lack the strength to transport large quantities of drinking water, since they have neither reinforcing elements nor appropriate construction.

European patent application EP-A-0213087 de-

scribes a system for sea transportation of organic solvents lighter than water, such as hydrocarbons, consisting in a number of flexible cylindrical tanks with rounded ends, linked to each other in a string. They are transported by towing the string of tanks using a vessel, and the objective of the patent consists in selection of the plastic material, polyethylene, for its better resistance to degradation by organic solvents, and in the system of linkage between the tanks to form a string.

There thus remains a need to achieve a container for transportation of drinking water which is capable of transporting large quantities of same by towing it behind a vessel and at the same time possessed of the desired characteristics of flexibility and lightness, yet retaining excellent qualities in respect of its structural strength, seagoing qualities and simplicity of construction and handling.

Object of the invention

The object of the present invention is a flexible and elastic container, of spindle shape, for the maritime transportation of large quantities of drinking water, which container has excellent characteristics in respect of lightness, strength, simplicity of construction and handling and seagoing capacity, so that it can be transported towed behind a relatively light craft.

Description of the invention

The container of the present invention consists essentially of:

- a) a cylinder, substantially spindle-shaped, with mouths at its two ends, having walls made of a flexible and elastic synthetic plastic material,
- b) a number of longitudinal reinforcing members, also flexible and elastic,
- c) a filling and emptying tube, provided with a plurality of orifices for the entry and exit of the water, and passing through the container from one end to the other, running along the bottom of same, and projecting through its two mouths,
- d) two floating platforms which support the filling and emptying valves and are connected to both ends of the filling and emptying tube,
- e) two linkage cylinders situated at the mouths of the container, through which the filling and emptying tube passes and upon which the walls of the container converge and are secured and the reinforcement members are connected,
- f) a guide cable for towing the container, one end of which is hooked to the towing vessel and the other to either of the two linkage cylinders.

The walls of the container can be of any synthetic material of an elastic nature, although preferably they are made of flexible PVC, as that material provides

highly suitable characteristics of flexibility, elasticity and strength. If so wished, the plastic material can be reinforced by a web of textile fibres.

The reinforcement members can be configured by means of a metal or synthetic cable of sufficient elasticity and flexibility, preferably braided, running through a tube of plastic material such as polyethylene, which can be secured to the surface of the container by means of a strip which can, amongst other materials, be of PVC, which is stuck onto the said surface using conventional methods, that is, using thermal methods or adhesives. If so wished, the space left between the plastic tube and the cable can be filled with a shock-absorbing polymeric material, such as expanded polystyrene.

The filling and emptying tube can also be of any appropriate synthetic plastic material, preferably of thermally mouldable semi-rigid PVC for the part inside the container and of polyethylene for the part outside said container and occupying most of the mouths of the container. Said tube runs longitudinally through the entire container, following the lower part of its outline, and is provided with a plurality of orifices of between 20 and 70 mm diameter which permit uniform filling and emptying of the container and act to a certain extent as a barrier to solid residues of a certain size which might accompany the water. The filling and emptying tube is prolonged, either as a single-piece tube or by means of jointing with another tube, outside the mouth of the container until it connects with the filling and emptying valve systems situated on the respective floating platforms.

The floating platforms each contain valve systems for the emptying and filling of the container, connected, as explained above, with the ends of the emptying and filling tube. If so wished, the platforms can be provided with the pumping units necessary for transferring the water or they can be connected to independent pumping systems situated on the towing craft, anchorage port or ancillary vessels. Under sea-going conditions, the platform nearest to the stern of the vessel can be directly towed by same by means of a tow rope, in order to avoid collisions with the body of the container.

The linkage cylinders situated on the mouths of the container are of a diameter practically coinciding with that of the mouths of the container and they can be made of strong metal such as stainless steel, with a protective anti-corrosion coating, or of synthetic plastic materials possessing sufficient strength. The ends of the container walls and the filling tube are welded onto said linkage cylinders using any conventional technique, such as injection of a polymeric material like expanded polystyrene. Said cylinders also have on their outer surface a system for anchoring the cables of the reinforcement members, which link can be provided by a metal band which secures the members against the cylinder. On their front part, that is,

outside the body of the container, the linkage cylinders are also provided with a conventional system for anchorage of the towing guide cable. It can therefore be understood that the linkage cylinders must be robust and strong items, for they have to withstand all the traction force.

The towing guide cable must also be very strong, preferably of metal, being anchored by one end, as indicated above, to the linkage cylinder, and by the other end to the towing vessel. For a better distribution of traction forces it is advantageous, though not essential, for at least a certain length of the guide cable to be held substantially in the same direction as the axis of the container. To that end the tugboat can be provided with a towing system which permits such an arrangement. The length of the guide cable must logically be greater than the length of the portion of filling and emptying tube which is outside the body of the container.

Advantageously, the container of the invention is provided with a system of two or more floats situated longitudinally on its top part in order to stabilize the container and prevent it turning about its axis. The floats can be formed by hollow rigid PVC tubes with their ends closed.

To its top part, making use of the float structures, the container can be provided with attachments for the safety signalling devices, whether lit-up or otherwise, required by the commercial navigation regulations, together with any other localization instrument, such as radar reflector screens, radio range beacons, etc.

In respect of the functional aspects of the container of the invention, it can be stated that when it is empty it is very light in weight in relation to its weight when filled with water, and it is very flexible, which means that it can be towed unladen with great ease.

Prior to filling the container is completely emptied of air by application of a suction pump to one of its mouths. Thus, during filling of same no overpressure arises due to the air displaced, while during emptying it is not necessary to compensate for the depression produced, since its flexible and elastic nature means that the container collapses without suffering damage.

Once the container is full of water and is at sea, owing to the density of the drinking water being only slightly lower than that of the sea water, to the compensation arising in the materials used in its manufacturing and to the action of the floats, the container is practically covered by the sea water, that is, it can travel on the surface or slightly submerged, with only the signalling systems projecting above the water. In this situation, its spindle-shaped exterior is especially suitable for offering minimum resistance to the sea water.

It is clear that a single tugboat could tow one container or several containers at once, arranged in fan

or cluster form.

In respect of dimensions, the container of the invention can be as variable as desired, depending on the quantity of water to be transported. Nevertheless, the larger the quantity of water to be transported the more effective and profitable utilization of the container will be, so it is designed for the transportation of large quantities, in principle exceeding 4,000 m³, while it can without problems hold quantities in excess of 25,000 m³.

The ratio of the diameter of the container to its length can vary, through it will usually lie between 1:10 and 1:30. The thickness of the container walls can be surprisingly small owing to the flexibility and tensionability of the material employed and the pressure compensation arising between that due to the water load, outwards, and that exercised by the sea water, inwards. For example, a container with transportation capacity of some 5,000 m³ needs only a wall thickness of the order of 1 mm.

The number of reinforcement members can also be variable, though as a guideline there may be a space of 1 to 3 metres between members at the middle zone of the container.

The advantages of the container of the invention compared to the previously known technique are clean, and can be summed up as follows:

- . Great manoeuvrability and seagoing qualities.
- . Great robustness and strength with minimum unladen weight.
- . Easy and low-cost construction.
- . Capacity for transportation of large quantities of drinking water using a vessel of relatively small size.
- . Small unladen volume, easy to transport.
- . Suitable for both long and short distances.

Description of the drawings

For a better understanding of the description of the present invention, this specification is accompanied as an integral part of same by three pages of drawings which, with illustrative and non-limiting character, show the following:

Figure 1 is an overall view of a specific embodiment of the container of the invention in seagoing position.

Figure 2 is a longitudinal view of the body of the container of the embodiment of Figure 1, with a section through the middle of same to show the interior details.

Figure 3 is a cross section of the aforesaid container.

Figure 4 shows a detail corresponding to the reinforcement members of the aforesaid container.

Figure 5 shows a detail of the filling and emptying tube inside the aforesaid container.

Figure 6 shows a detail of one of the mouths of

the container.

Description of a preferred embodiment

In Figure 1 the container -1-, in the shape of a spindle and full of water, is shown being towed by a vessel -2- by means of a guide cable -3-. The filling and emptying tube -5- projects from the two mouths of the container -6- and goes on to the floating platforms with the valves system -4-.

Figure 2, and the details of Figures 3, 4, 5 and 6, show the following:

The body of the container, whose walls are made of flexible PVC sheeting, presents in a longitudinal direction a number of reinforcement members -8- which, as can be observed in the detail of Figure 4, are made up of cable -12- passed through a polyethylene tube -13-. The reinforcement members are stuck onto the external surface of the container walls by means of a PVC strip -14- attached using a suitable adhesive. The space formed inside the tube -13- is filled by injection of expanded polystyrene, not shown in the figure.

The filling-emptying tube -5- runs through the entire length of the container -1-, between its two mouths -6-, passing along the bottom part of the container. The tubing -5- has a plurality of orifices -7-, whose arrangement can be observed better in Figure 5, suitable for the entry and exit of the water.

The mouths of the container -6- are formed by the metal linkage cylinder -16-, through which the filling and emptying tube -5- passes concentrically. On the exterior part of the linkage cylinder there is an anchorage point -15- which serves to secure the towing guide cable -3-. The ends of the reinforcement members -8- are anchored on a strip -18-, and they come together and are secured around the linkage cylinder by means of the band -17-. Although not shown in Figure 6, the ends of the container walls are also secured to the linkage cylinder, as are the filling and emptying tube -5- and the reinforcement members -8-.

Figures 2 and 3 show the longitudinal float installation -9-, consisting of hollow PVC tubes, which serve to stabilize the container during the sea journey. Signalling lights -10- are fitted on said floats, secured by stay members -11-.

Independent of the object of the present invention shall be the materials employed, together with the shapes and dimensions of the various elements which make up the container of the invention and all the accessories which may be presented, as long as they do not affect the essential nature of the said invention.

Claims

1. Flexible container for the transportation of water

- by sea by means of dragging or towing by a vessel, characterized in that it consists essentially of:
- a) a cylinder (1), substantially spindle-shaped, with mouths (6) at its two ends, having walls made of a flexible and elastic synthetic plastic material,
 - b) a number of longitudinal reinforcing members (8), also flexible and elastic,
 - c) a filling and emptying tube (5), provided with a plurality of orifices (7) for the entry and exit of the water, and passing through the container from one end to the other, running along the bottom of same, and projecting through its two mouths (6),
 - d) two floating platforms (4) which support the filling and emptying valves and are connected to both ends of the filling and emptying tube (5),
 - e) two linkage cylinders situated (16) at the mouths of the container, through which the filling and emptying tube (5) passes and upon which the walls of the container converge and are secured and the reinforcement members (8) are connected, and
 - f) a guide cable (3) for towing the container, one end of which is hooked to the towing vessel (2) and the other to either of the two linkage cylinders (16).
2. Container, as claimed in Claim 1, characterized in that the container walls are, substantially, of flexible PVC.
 3. Container, as claimed in Claim 1, characterized in that each reinforcement member (8) is made up of a cable (12) passed through a tube of synthetic material (13) which is stuck on the external surface of the container (1) by means of a strip of synthetic material (14) attached using a suitable adhesive.
 4. Container, as claimed in Claim 1, characterized in that the linkage cylinders (16) are provided with a system for anchoring the reinforcement members (8).
 5. Container, as claimed in Claims 1 and 4, characterized in that the reinforcement members (8) come together and are secured to the exterior surface of the linkage cylinder by means of a flange (17).
 6. Container, as claimed in Claim 1, characterized in that some longitudinal floats (9) are arranged on the top part of the container (1).
 7. Container, as claimed in Claims 1 and 6, characterized in that anchorage points are placed on the floats (9) and can hold signalling and navigation systems.
 8. A procedure for transporting drinking water by sea by means of towing a flexible container behind a vessel, characterized in that the container presents the characteristics described in Claim 1.
 9. A procedure, as claimed in Claim 8, characterized firstly in that all the air is sucked from the container through any of the valves situated on the floating platforms (4); the container is then filled with drinking water by pumping of same through any of the above-mentioned platforms (4); the container is then hooked to a tugboat (2) and transported by sea to the unloading zone where, finally, the drinking water is discharged by pumping through the valves situated on either of the floating platforms (4), the container being subsequently transported back to the point of origin by towing it unladen using the tugboat.

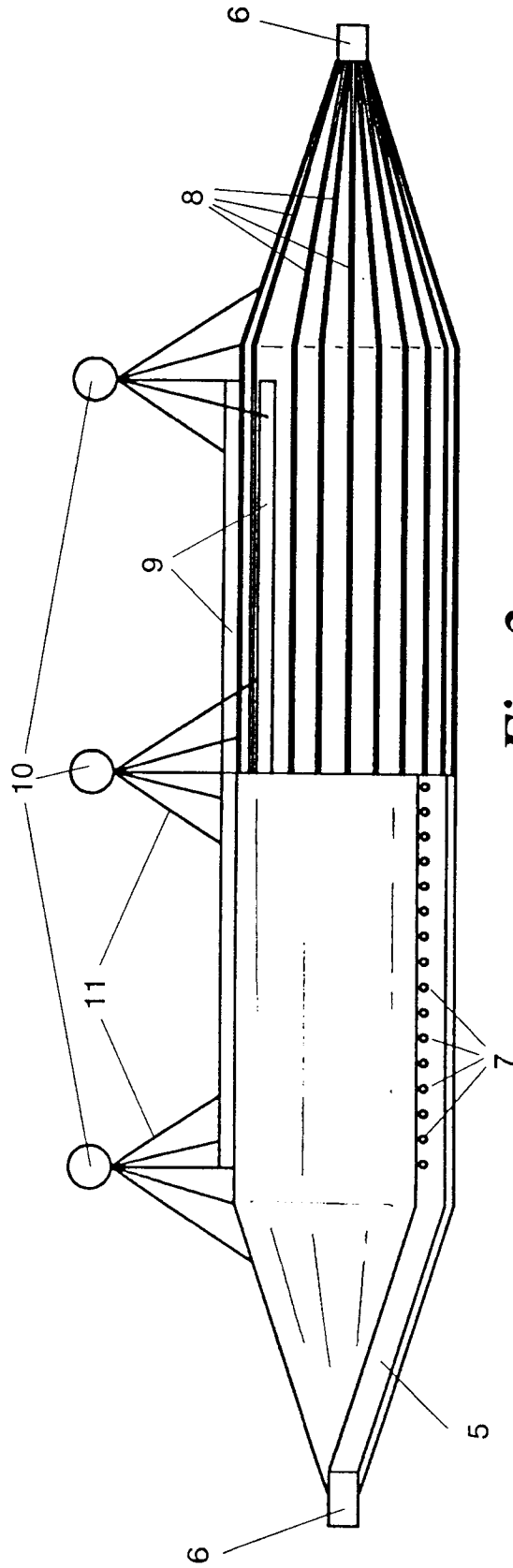
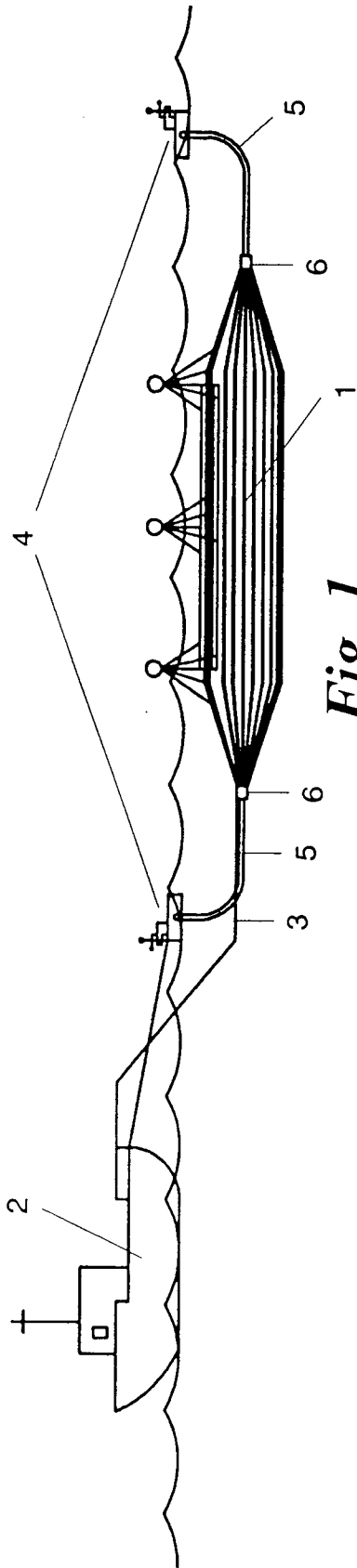

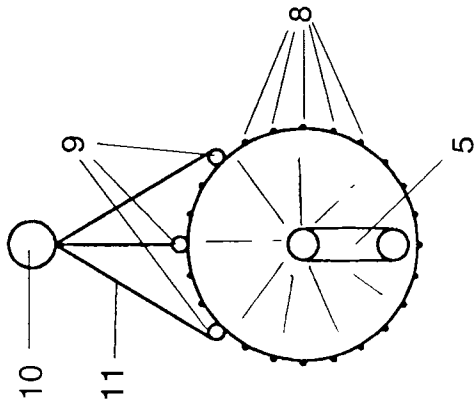

Fig. 3

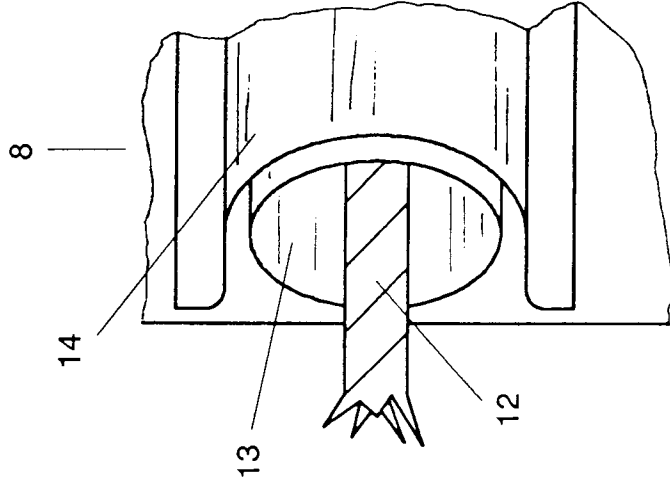

Fig. 4

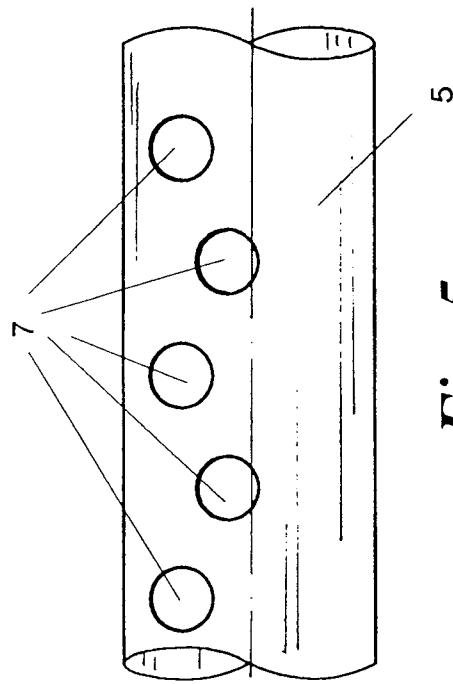

Fig. 5

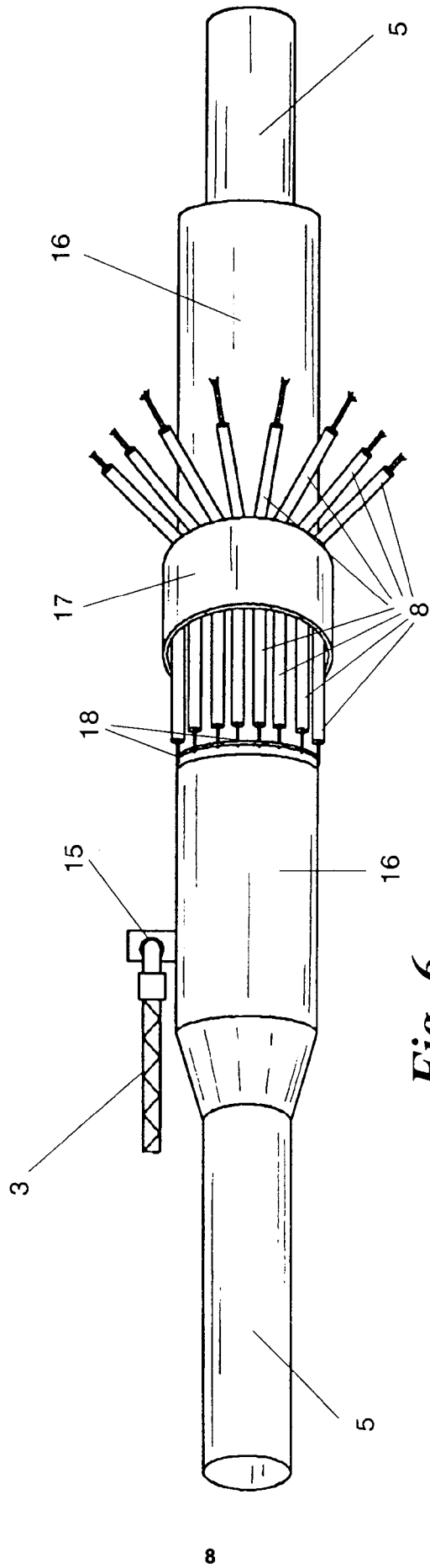

Fig. 6



European Patent
Office

EUROPEAN SEARCH REPORT

Application Number
EP 95 50 0084

DOCUMENTS CONSIDERED TO BE RELEVANT			
Category	Citation of document with indication, where appropriate, of relevant passages	Relevant to claim	CLASSIFICATION OF THE APPLICATION (Int.Cl.6)
A	GB-A-821 195 (ERNST HANS DOERPINGHAUS) * the whole document * ---	1,2,4,5, 8	B63B35/28 B65D88/78
A	DE-B-11 70 312 (CONTAINER PATENT COMPANY GMBH) * column 5, line 29 - column 6, line 27; figures * ---	1,2,4,5, 8,9	
A	BE-A-561 390 (SOC. D'ETUDES POUR LE STOCKAGE ET LE TRANSPORT SOUS-MARINS DES FLUIDES) * claims; figures * ---	1,6,7	
A	DE-B-12 14 177 (FOLKER BURKANT) * column 2, line 35 - line 49; figures * ---	1	
A	DE-B-11 99 649 (CONTINENTAL GUMMI-WERKE AKT.) * column 5, line 6 - column 6, line 31; figures * -----	1	
			TECHNICAL FIELDS SEARCHED (Int.Cl.6)
			B63B B65D
The present search report has been drawn up for all claims			
Place of search THE HAGUE		Date of completion of the search 5 October 1995	Examiner Van Rollegem, F
CATEGORY OF CITED DOCUMENTS		T : theory or principle underlying the invention E : earlier patent document, but published on, or after the filing date D : document cited in the application L : document cited for other reasons & : member of the same patent family, corresponding document	
X : particularly relevant if taken alone Y : particularly relevant if combined with another document of the same category A : technological background O : non-written disclosure P : intermediate document			

EPO FORM 1503 03.82 (P04C04)