

(19)



Europäisches Patentamt

European Patent Office

Office européen des brevets



(11)

**EP 0 688 599 B1**

(12)

**EUROPEAN PATENT SPECIFICATION**

(45) Date of publication and mention  
of the grant of the patent:  
**12.08.1998 Bulletin 1998/33**

(51) Int. Cl.<sup>6</sup>: **B01F 7/06, B01F 3/04**

(21) Application number: **95850101.7**

(22) Date of filing: **07.06.1995**

**(54) Mixer with a cooling device for Bingham liquids**

Mischer mit Kühlvorrichtung für Bingham Flüssigkeiten

Mélangeur pourvu d' un dispositif de refroidissement et apte pour mélanger des liquides de Bingham

(84) Designated Contracting States:  
**DE FR GB IT NL**

(30) Priority: **22.06.1994 SE 9402194**

(43) Date of publication of application:  
**27.12.1995 Bulletin 1995/52**

(73) Proprietor: **ITT FLYGT AB**  
**S-171 25 Solna (SE)**

(72) Inventor: **Fries, Hjalmar**  
**S-16358 Spanga (SE)**

(74) Representative: **Larsson, Sten**  
**ITT FLYGT AB**  
**Box 1309**  
**171 25 Solna (SE)**

(56) References cited:  
**EP-A- 0 286 611**

- **PATENT ABSTRACTS OF JAPAN vol. 6, no. 49**  
**(C-96) (927) 31 March 1982 & JP-A-56 161 893**  
**(KURIMOTO TEKKOSHO) 12 December 1981**

**EP 0 688 599 B1**

Note: Within nine months from the publication of the mention of the grant of the European patent, any person may give notice to the European Patent Office of opposition to the European patent granted. Notice of opposition shall be filed in a written reasoned statement. It shall not be deemed to have been filed until the opposition fee has been paid. (Art. 99(1) European Patent Convention).

## Description

The invention concerns a mixer device for operation in viscous liquids where amounts of solid bodies are frequent.

Mixers of this type comprise a driving unit such as an electric motor, a propeller and a driving shaft there between. The propeller may be designed with two or more vanes and to be driven with various speeds depending on type of use.

Mixers are used within different fields for homogenizing and to keep particles in suspension in liquids for different industrial processes, in farming, for treatment of sewage water etc. The mixer may be arranged horizontally or vertically or in different angle positions there between. It can also be arranged to move in such a way that the flow from the mixer is caused to sweep over larger areas or being directed towards certain spots within the liquid tank.

In order to obtain an effective mixing or flow a jet ring is often arranged around the propeller having a diameter somewhat exceeding that of the propeller and a normally relatively limited axial extension. With no jet ring present a dominating radial flow is obtained which means that the axial flow through the machine becomes very limited as the same amount of liquid is rapidly sucked back to the propeller. In addition there is a leakage between the pressure and the suction side of the propeller which further decreases the axial flow. According to known practice the jet ring is normally designed as a cylinder having a somewhat expanding collar at its inlet to facilitate the inflow. Such jet rings are shown in the Swedish Design Registrations No:s 34601 and 39392.

JP-A-56 161 893 discloses a propeller-type axial-flow pump provided with a surrounding guide wall which in combination with a jet ring of smaller diameter reduces the lift head of air suction.

EP-A-0 286 611 discloses a submersible mixer provided with an oscillating device which permits to obtain an automatically varying direction of the mixer without any need for an external energy source, but only by the force created by the mixer itself.

The electric motor is cooled by the surrounding medium which calls for a certain flow around the motor, which flow normally is obtained by the mixer itself. When mixing liquids that demand a certain shear stress to be exceeded before any movement is created, Bingham liquids, problems may occur to obtain a flow strong enough. This might cause the motor to be overheated.

The invention concerns a mixer device for solving the problem mentioned above, wherein the device comprises the features as defined in claim 1, with preferred features as given in claim 2. The invention is described more clearly below with reference to the enclosed drawings.

Fig 1 shows a mixer provided with a cooling device according to the invention, while Figs 2 and 3 show

flows around a mixer not provided with a cooling device, Fig 2, and with a cooling device, Fig 3.

In the drawings 1 stand for a mixer with a driving unit, electric motor 2 and a propeller 3. 4 stands for a jet ring and 5 an extension of this.

With reference to Fig 2 the conditions when mixing Bingham liquids are discussed. The mixer here creates a flow symbolized by the arrows in the light part of the drawing. The area close to the electric motor is not included in the flow which means an insufficient heat exchange between the motor housing and the surroundings.

In Fig 3 is shown the flow increase or the extension of the area where flow takes place, which is obtained by help of the invention. The propeller creates an under pressure at its inlet side, inside of the jet ring, which means that critical shear stress is exceeded and a flow is obtained through the jet ring along the wall of the motor housing which thus is given an effective cooling.

In the example above an extended jet ring has been used to obtain an effective cooling of the motor housing. It is however possible, according to the inventor, to arrange one or several means around the motor, parted from the jet ring, which obtain the necessary flow.

## Claims

1. A mixer device for Bingham liquids comprising an electric motor and a propeller with a driving shaft therebetween, said mixer device, including the electric motor, being meant to operate submersed in the mixed medium, wherein said mixer device is provided with a cylindrical wall (5) which partly or entirely surrounds the mantel surface of the electric motor (2), to obtain an intensifying of the media and heat exchange at said surface for cooling the electric motor.
2. A mixer device according to claim 1, characterized in that the wall (5) is an extended part of the jet ring (4,5) surrounding the propeller (3).

## Patentansprüche

1. Mischvorrichtung für Bingham-Flüssigkeiten, mit einem Elektromotor und einem propellerartigen Laufrad und einer dazwischen angeordneten Antriebswelle, wobei die Mischvorrichtung einschließlich des Elektromotors dazu gedacht ist, eingetaucht in das zu mischende Medium zu arbeiten, wobei die Mischvorrichtung mit einer zylindrischen Wand (5) versehen ist, die die Mantelfläche des Elektromotors (2) teilweise oder vollständig umschließt, um dadurch eine Intensivierung des Austauschs von Medium und Wärme an der Mantelfläche zum Kühlen des Elektromotors zu erzielen.

2. Mischvorrichtung nach Anspruch 1, dadurch gekennzeichnet, daß die Wand (5) ein verlängerter Teil eines Strahlrings (4, 5) ist, der das Laufrad (3) umgibt.

5

### Revendications

1. Dispositif mélangeur pour liquide de Bingham comprenant un moteur électrique et une hélice avec un arbre d'entraînement interposé entre le moteur et l'hélice, ledit dispositif mélangeur comportant le moteur électrique pour fonctionner à l'état immergé dans le milieu mélangé, dans lequel ledit dispositif mélangeur est muni d'une paroi cylindrique (5) qui entoure partiellement ou entièrement la surface de la paroi extérieure du moteur électrique (2) pour obtenir une intensification de l'échange thermique et de milieu au niveau de ladite surface pour refroidir le moteur électrique.
2. Dispositif mélangeur selon la revendication 1, caractérisé en ce que la paroi (5) est une partie prolongée d'un anneau de jet (4,5) entourant l'hélice (3).

10

15

20

25

30

35

40

45

50

55

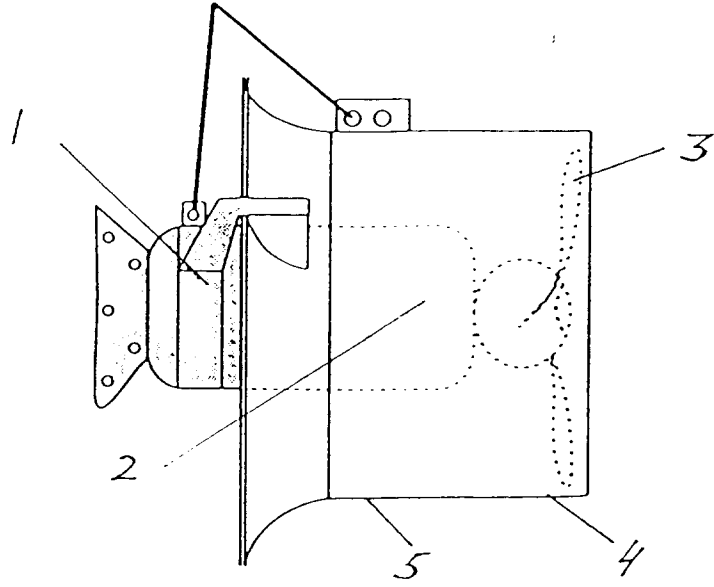

Figur 1

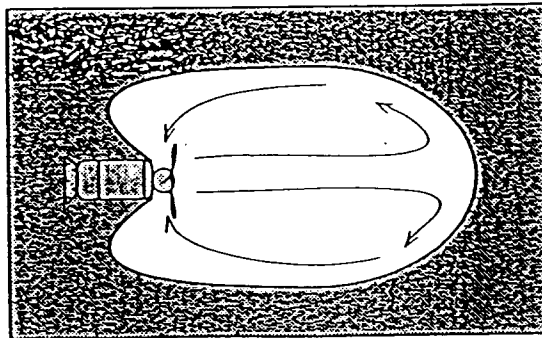

Figur 2

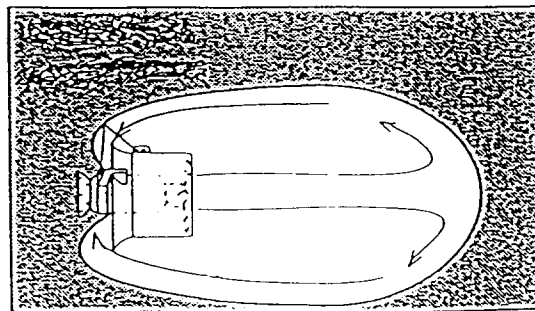

Figur 3