

(19)



Europäisches Patentamt
European Patent Office
Office européen des brevets



(11)

EP 0 690 429 B1

(12)

EUROPEAN PATENT SPECIFICATION

(45) Date of publication and mention
of the grant of the patent:
21.01.1998 Bulletin 1998/04

(51) Int Cl.6: **G09F 13/04**

(21) Application number: **95304489.8**

(22) Date of filing: **26.06.1995**

(54) **A light box**

Leuchtkasten

Caisson lumineux

(84) Designated Contracting States:
BE DE ES FR GB IE IT NL

(30) Priority: **01.07.1994 GB 9413234**

(43) Date of publication of application:
03.01.1996 Bulletin 1996/01

(73) Proprietor: **MORE GROUP UK LIMITED**
London W1R 3PA (GB)

(72) Inventors:
• **Kimber, Garth**
Amersham, Buckinghamshire HP6 5DD (GB)

- **Bradbury, Stephen**
Huddersfield, West Yorkshire (GB)
- **Davey, Kieran**
Amersham, Buckinghamshire (GB)
- **Barton, Clive**
Hayling Island, Hampshire (GB)

(74) Representative: **Jackson, Richard Eric**
Carpmaels & Ransford,
43 Bloomsbury Square
London WC1A 2RA (GB)

(56) References cited:
DE-U- 9 317 852 **GB-A- 2 100 043**
GB-A- 2 109 607 **US-A- 4 327 513**

EP 0 690 429 B1

Note: Within nine months from the publication of the mention of the grant of the European patent, any person may give notice to the European Patent Office of opposition to the European patent granted. Notice of opposition shall be filed in a written reasoned statement. It shall not be deemed to have been filed until the opposition fee has been paid. (Art. 99(1) European Patent Convention).

Description

This invention relates to light boxes, and in particular to light boxes for advertisements to be displayed in public places, such as at bus shelters.

Street advertisements on bill boards or the like are well known and attract significant revenue for the owner of the bill board. Other ways of providing advertising space have been sought and, as a result, free standing advertising displays are becoming more common. Further, shelters, such as bus shelters, often now incorporate advertising space.

Advertising display devices have progressed significantly over the last few years and now often include a light source within the device for illuminating the advertisement from within. Such light boxes comprise a frame, at least one door for accessing an advertisement mounted within the light box and a light source within the light box for illuminating the advertisement or advertisements for viewing from the outside of the light box. Such prior art light boxes have, in general, been relatively simple in their design.

As a result of vandalism, bus shelters are often destroyed with the glass of the shelter windows being smashed. This vandalism also extends to the light boxes associated with the shelters and can result in significant expense being incurred to replace or restore a light box which has been destroyed or damaged. The present invention aims to reduce the loss caused by vandalism by providing a light box which can be readily restored to its former glory without significant expense.

With the foregoing aim in mind, the present invention provides a light box for a bus shelter or the like, the light box comprising a support frame, a display surface for an advertisement supported by the frame and a light source within the frame for illuminating the display surface, wherein cladding is applied to the support frame to define an exterior surface of the light box, the cladding being releasable from within the light box to enable the cladding to be replaced.

By making the cladding removable, damage to the exterior of the light box can be quickly repaired. Further, by designing the cladding to be released from the light box from within the light box, the cladding is unlikely to be removed by vandalism of the exterior of the light box.

Preferably the display surface is formed on a diffuser behind a door of the light box. More preferably, the door includes a clear plastics panel, made of polycarbonate or any other appropriate material, through which the advertisement positioned behind the door within the light box can be viewed.

The door is preferably hinged to the support frame to facilitate access into the light box.

A locking mechanism is preferably provided for retaining the door in a closed position. As a result, vandals cannot obtain access to the interior of the light box.

The diffuser preferably carries clips for receiving an advertisement to be held adjacent the display surface.

More preferably, the clips are ball clips mounted on the support frame at the top of the light box, in use, such that the advertisement hangs from the clips, in use.

A diffuser is preferably positioned between the light source and the display surface, the diffuser being suspended from the support frame. In a preferred embodiment, the diffuser is manufactured from fibreglass.

The light source may be one or more fluorescent tube suspended from the support frame.

Two display surfaces may be provided, illuminated by a single light source. In such an embodiment, one display surface faces in one direction and the other display surface faces in the opposite direction.

The cladding is preferably made of metal, although any other suitably strong material could alternatively be used. The cladding is, however, most preferably made of aluminium or steel.

The cladding preferably clips onto the support frame with a snap fit. As a result, removal of the cladding from the exterior of the light box is extremely difficult. However, by accessing the cladding from within the light box, a sharp tap against the cladding may be sufficient to dislodge the cladding prior to the remainder of the cladding being peeled off the support frame.

In a preferred embodiment, the support frame includes at least one aperture through which a rod can be poked to release the cladding from the support frame.

A weather seal is preferably provided around the or each door to prevent the ingress of rain water or other weather.

In one embodiment of the present invention, a base unit is provided for carrying the light box. The base unit preferably includes some form of reinforcement, such as steel rods, which engage the support frame of the light box.

According to another aspect of the present invention, there is provided a shelter incorporating at least one light box as herein defined.

A specific embodiment of the present invention is now described, by way of example only, with reference to the accompanying drawings, in which:-

Figure 1 is a front view of a light box according to the present invention;

Figure 2 is a side view of the light box of Figure 1; Figure 3 is a view in the direction X-X as shown in Figure 1;

Figure 4 is a view in the direction Y-Y as shown in Figure 1;

Figure 5 is a view in the direction Z-Z as shown in Figure 1;

Figure 6 is a view in the direction W-W as shown in Figure 1; and

Figure 7 is a sectional view from above of a second embodiment of light box according to the present invention in position adjacent a support post of a shelter.

With reference to Figures 1-6 of the accompanying drawings, a display device comprises a light box 1 according to the present invention supported by a base 3 for anchoring the display unit to the ground. The light box 1 comprises a generally rectangular support frame 5 formed from lengths of a profiled extrusion. The shape of the extrusion profile can be seen in Figures 3, 4 and 6. The support frame 5 carries a pair of doors 7 hingedly connected to the support frame 5 as shown in Figure 3. In this regard, the doors 7 are hinged at their tops to the support frame 5 to enable access to be obtained to the interior of the light box 1 for mounting of an advertisement or the like in the light box 1.

Each door 7 comprises a metal frame 9 defining an opening filled by a window 11 made of plastics material, such as polycarbonate. Towards the bottom of each door 7, a locking mechanism 12 is provided to lock securely the door to the support frame 5 to prevent unwanted access to the interior of the light box 1.

Ball type clips 13 are mounted towards the top of the light box 1 to receive posters or other advertisements to be displayed by the light box 1. By positioning the clips 13 towards the top of the light box 1, it is a simple matter for a door 7 to be opened and for a poster or other advertisement to be received by the clips 13 such that the poster hangs neatly behind the window 11 of the door 7 when the door has once again been closed and locked. The advertisement can then be viewed through the window 11 by persons passing the display unit.

A light source (not shown), such as one or more fluorescent tubes, is positioned within the light box 1 between the two doors 7. A diffuser 15, preferably made of fibreglass, is held by the support frame 5 between the light source and each door 7 such that light from the light source is spread evenly across the rear of the advertisement, thereby illuminating the advertisement for display purposes. More particularly, the extrusion used for the support frame 5 includes two C-shaped sections 17 for receiving correspondingly shaped portions of two diffusers 15 as shown in Figure 3. Positioning of each diffuser 15 can, therefore, be achieved simply by sliding the diffuser 15 along the C-shaped section 17.

A neoprene seal 19 is positioned between the support frame 5 and each door 7 to ensure that the inside of the light box 1 remains watertight against rain or other weather conditions.

With regard to the base 3, this comprises a reinforced frame 21 extending from feet 23 upwards into the support frame 5 of the light box 1. As a result, the light box 1 is provided with significant rigidity and is held firmly in position wherever the feet 23 of the base 3 are entered into the ground. As can be seen from Figure 4, the base 3 includes front and rear walls 25 which bow outwardly to produce an attractive appearance. At each end of the base 3, cladding 27 is provided which defines an essentially smooth curved exterior surface. The cladding 27, which is formed by extrusion, has a section

which mates with the profile of the support frame 5 by means of a snap fit. More particularly, the cladding 27 includes two legs 29 extending inwardly towards the support frame 5. Each leg 29 includes a stop 31 and a barb 33 for engaging an upstand 35 incorporating a small step 37 formed as part of the profile of the support frame 5. The legs 29 are slightly resilient, due to the nature of the aluminium from which the cladding 27 is manufactured, to enable the mounting of the cladding 27 with a snap fit. Once the cladding 27 has been positioned on the support frame 5, it is extremely difficult, if not impossible, to remove the cladding 27 from the support frame 5 by means external to the display unit.

The edges 38 of the cladding 27 are shaped with three fingers for abutment against flange 39 of the support frame 5. As a result, a good seal is formed at the juncture between the edges 38 and the support frame 5, thereby preventing a vandal from prizing the cladding 27 from the support frame 5.

Although the drawings show in detail the cladding 27 applied to the base 3 of the display unit, the sides of the light box 1 themselves also incorporate the same cladding 27 attached to the support frame 5 in like manner. In contrast, at the top of the light box 1, a substantially flat piece of cladding 41 is used to seal the top of the support frame 5, as shown in Figure 3. In this regard, the flat cladding 41 carries threaded studs 43 which pass through holes in a sheet 45 attached to the support frame 5. Nuts 47 are applied to the threaded studs 43 to retain the flat cladding 41 in position. Grommets 49 fill holes in the flat cladding 41 through which access can be obtained to the hinges of the doors 7, in the event that the doors 7 need to be removed.

In the event that a light box according to the present invention is vandalised with a heavy object or spray paint, for example, it is a relatively simple matter to remove the cladding 27,41 from the light box 1. New cladding can then be applied to the display unit to improve the appearance of the display unit without incurring the significant cost of completely replacing the display unit or the component parts thereof. More particularly, if the cladding 27 is to be removed, it is simply necessary to give the cladding 27 a sharp tap from within the light box 1 to separate the legs 29 of the cladding 27 from the upstands 35 of the support frame 5. This can be achieved by passing a rod through an aperture in the support frame 5. Once the cladding 27 has been forced away from the support frame 5 in at least one position, the remainder of the cladding 27 can be "peeled" off the support frame 5.

With regard to the flat cladding 41, this can simply be removed from the support frame 5 by undoing the nuts 47 holding the flat cladding 41 on the support frame 5. Once again this needs to be achieved from within the light box 1. Further, if the doors 7 have been vandalised, these can be removed for repair or replacement. Hence, the external appearance of the complete display unit can be restored simply by replacing the cladding and

doors of the unit. The remainder of the display unit can be left in situ. This is a distinct advantage over the prior art display units, wherein the whole unit has often had to be replaced after an attack of vandalism.

With regard to Figure 7, two other forms of cladding 51,53 are shown. The remainder of the display unit is essentially the same as that of the previous embodiment. Hence, it should be appreciated that a single type of light box 1 may be used for a number of different applications, simply by using the appropriate type of cladding on the support frame 5.

In the particular embodiment shown in Figure 7, the display unit is designed to stand below a bus shelter, a part 55 of which is shown in Figure 7. More particularly, the bus shelter 55 includes a support pole 57, a glass or plastics panel 59 and a light box 1 according to the present invention. One end of the light box 1 incorporates a first style of cladding 51 which is designed to provide an appearance similar to that of the hexagonal exterior of the support pole 57. Once again, the cladding 51 is held on the support frame 5 by means of legs 29 incorporating a stop 31 and a barb 33. At the other end of the light box 1, two separate pieces of cladding 53 are attached to the support frame 5 by means of screws 61 passing through the support frame 5 and engaging recesses in the cladding 53. Once again, the exterior of the cladding 53 is shaped to match the support pole 57 used in the bus shelter 55. However, this time an opening 63 is provided for receiving the support pole 57.

Any other suitable style of cladding could, of course, be used with the light box without departing from the scope of the present invention. The style of the cladding will simply depend upon the application in which it is to be used.

It will of course be understood that the present invention has been described above purely by way of example, and that modifications of detail can be made within the scope of the invention, which is defined by the appended claims.

Claims

1. A light box for a bus shelter or the like, the light box (1) comprising a support frame (5), a display surface for an advertisement supported by the frame and a light source within the frame for illuminating the display surface, characterised in that cladding (27) is applied to the support frame to define an exterior surface of the light box, the cladding being releasable from within the light box to enable the cladding to be replaced.
2. A light box as claimed in claim 1, wherein the display surface is defined by a door (7) of the light box.
3. A light box as claimed in claim 2, wherein the door (7) is hinged to the support frame (5) to facilitate

access into the light box.

4. A light box as claimed in claim 2 or claim 3, wherein a locking mechanism is provided for retaining the door in a closed position.
5. A light box as claimed in any preceding claim, wherein the support frame (5) carries clips (13) for receiving an advertisement to be held adjacent the display surface, the clips being ball clips mounted on the support frame at the top of the light box, in use, such that the advertisement hangs from the clips, in use.
6. A light box as claimed in any preceding claim, wherein a diffuser (15) is positioned between the light source and the display surface, the diffuser being manufactured from fibreglass and suspended from the support frame.
7. A light box as claimed in any preceding claim, wherein the cladding is made of metal, preferably aluminium.
8. A light box as claimed in any preceding claim, wherein the cladding clips onto the support frame with a snap fit.
9. A light box as claimed in any preceding claim, wherein the cladding comprises a pair of support legs (29) which each incorporate a barb (33) for engaging a step (35) formed on the support frame to attach the cladding to the support frame.
10. A light box as claimed in any preceding claim, wherein the support frame includes at least one aperture through which a rod can be poked to release the cladding from the support frame.
11. A light box as claimed in any preceding claim, wherein a base unit (3) comprising a reinforced frame carries the light box.
12. A shelter incorporating at least one light box according to any preceding claim.

Patentansprüche

1. Leuchtkasten für einen Busunterstand oder dergleichen, wobei der Leuchtkasten (1) einen Trägerrahmen (5), eine Präsentationsfläche für eine vom Rahmen getragene Werbung und eine Lichtquelle innerhalb des Rahmens zur Beleuchtung der Präsentationsfläche hat, dadurch gekennzeichnet, daß Verkleidungen (27) auf den Trägerrahmen aufgebracht sind, um eine Außenfläche des Leuchtkastens zu definieren, wobei die Verkleidung von der

Innenseite des Leuchtkastens, um eine Auswechslung der Verkleidung zu ermöglichen, lösbar ist.

2. Leuchtkasten nach Anspruch 1, wobei die Präsentationsfläche gebildet wird durch eine Tür (7) des Leuchtkastens. 5
3. Leuchtkasten nach Anspruch 2, wobei die Tür (7) an dem Trägerrahmen (5) angelenkt ist, um den Zugang in den Leuchtkasten zu erleichtern. 10
4. Leuchtkasten nach Anspruch 2 oder 3, wobei ein Sperrmechanismus vorgesehen ist, um die Tür in einer geschlossenen Lage zu halten. 15
5. Leuchtkasten nach einem der vorhergehenden Ansprüche, wobei der Trägerrahmen (5) Clips (13) trägt, um eine Werbung aufzunehmen, die benachbart der Präsentationsfläche gehalten werden soll, wobei die Clips Kugelclips sind, die auf dem Trägerrahmen oben am Lichtkasten im Gebrauch angebracht sind, derart, daß die Werbung im Gebrauch von den Clips nach unten hängt. 20
6. Leuchtkasten nach einem der vorhergehenden Ansprüche, wobei ein Diffusor (15) zwischen der Lichtquelle und der Präsentationsfläche positioniert ist, und der Diffusor aus Fiberglas hergestellt ist und vom Trägerrahmen abgehängt ist. 25
7. Leuchtkasten nach einem der vorhergehenden Ansprüche, wobei die Verkleidung aus Metall, vorzugsweise aus Aluminium gemacht ist. 30
8. Leuchtkasten nach einem der vorhergehenden Ansprüche, wobei die Verkleidung auf den Trägerrahmen mit einem Schnappsitz einrastet. 35
9. Leuchtkasten nach einem der vorhergehenden Ansprüche, wobei die Verkleidung ein Paar von Trägerschenkeln (29) umfaßt, in die je ein Widerhaken (33) eingearbeitet ist, um gegen eine Abstufung (35) greifen, die auf dem Trägerrahmen ausgebildet ist, um die Verkleidung am Trägerrahmen zu befestigen. 40
10. Leuchtkasten nach einem der vorhergehenden Ansprüche, wobei der Trägerrahmen wenigstens eine Öffnung aufweist, durch welche eine Stange gestoßen werden kann, um die Verkleidung vom Trägerrahmen zu lösen. 50
11. Leuchtkasten nach einem der vorhergehenden Ansprüche, wobei eine Basiseinheit (3), die einen verstärkten Rahmen umfaßt, den Leuchtkasten trägt. 55
12. Unterstand, in den wenigstens ein Leuchtkasten nach einem der vorhergehenden Ansprüche einge-

baut ist.

Revendications

1. Caisson lumineux pour un abribus, ou analogue, le caisson lumineux (1) comprenant un cadre de support (5), une surface d'affichage pour une publicité supportée par le cadre, et une source lumineuse, à l'intérieur du cadre, pour éclairer la surface d'affichage, caractérisé en ce qu'un gainage (27) est appliqué au cadre de support pour définir une surface extérieure du caisson lumineux, le gainage pouvant se libérer de l'intérieur du caisson lumineux pour permettre le remplacement du gainage.
2. Caisson lumineux selon la revendication 1, dans lequel la surface d'affichage est définie par une porte (7) du caisson lumineux.
3. Caisson lumineux selon la revendication 2, dans lequel la porte (7) est articulée par rapport au cadre de support (5) afin de faciliter l'accès dans le caisson lumineux.
4. Caisson lumineux selon la revendication 2 ou la revendication 3, dans lequel un mécanisme de verrouillage est prévu pour retenir la porte dans une position de fermeture.
5. Caisson lumineux selon l'une quelconque des revendications précédentes, dans lequel le cadre de support (5) porte des attaches (13) pour recevoir une publicité qui doit être maintenue adjacente à la surface d'affichage, les attaches étant des attaches sphériques montées sur le cadre de support au sommet du caisson lumineux, en service, afin que la publicité pende des attaches, en service.
6. Caisson lumineux selon l'une quelconque des revendications précédentes, dans lequel un diffuseur (15) est placé entre la source lumineuse et la surface d'affichage, le diffuseur étant fabriqué à partir de fibre de verre et suspendu depuis le cadre de support.
7. Caisson lumineux selon l'une quelconque des revendications précédentes, dans lequel le gainage est réalisé en métal, de préférence en aluminium.
8. Caisson lumineux selon l'une quelconque des revendications précédentes, dans lequel le gainage est fixé sur le cadre de support grâce à un ajustement à encliquetage.
9. Caisson lumineux selon l'une quelconque des revendications précédentes, dans lequel le gainage comprend une paire de jambes de support (29) qui

renferment chacune un picot (33) destiné à venir en prise avec une partie en gradin (35) formée sur le cadre de support pour fixer le gainage au cadre de support.

5

- 10.** Caisson lumineux selon l'une quelconque des revendications précédentes, dans lequel le cadre de support comprend au moins un orifice à travers lequel une tige peut être insérée pour libérer le gainage du cadre de support.

10

- 11.** Caisson lumineux selon l'une quelconque des revendications précédentes, dans lequel une unité de base (3) comprenant un cadre renforcé porte le caisson lumineux.

15

- 12.** Abri renfermant au moins un caisson lumineux selon l'une quelconque des revendications précédentes.

20

25

30

35

40

45

50

55

FIG. 1

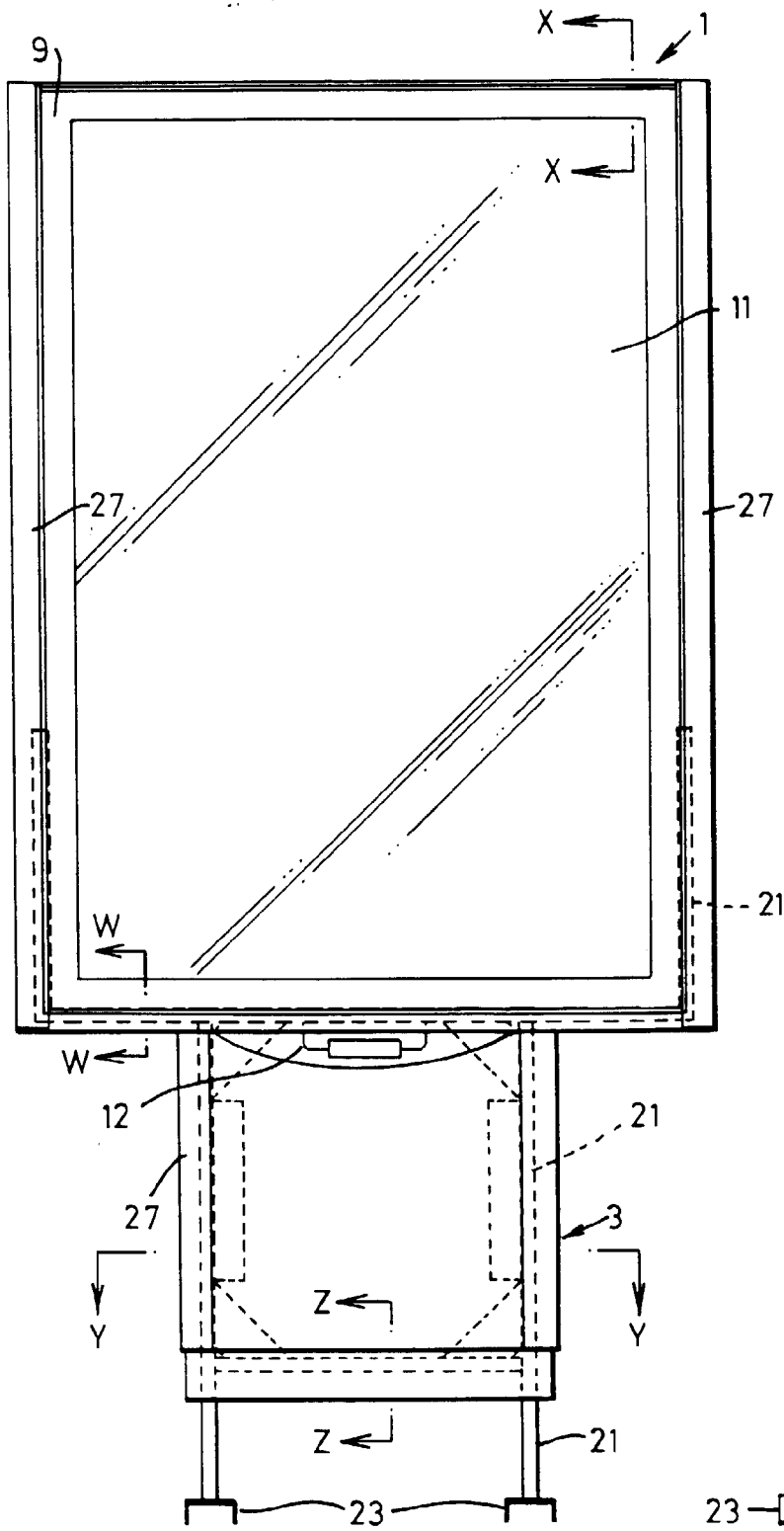

FIG. 2

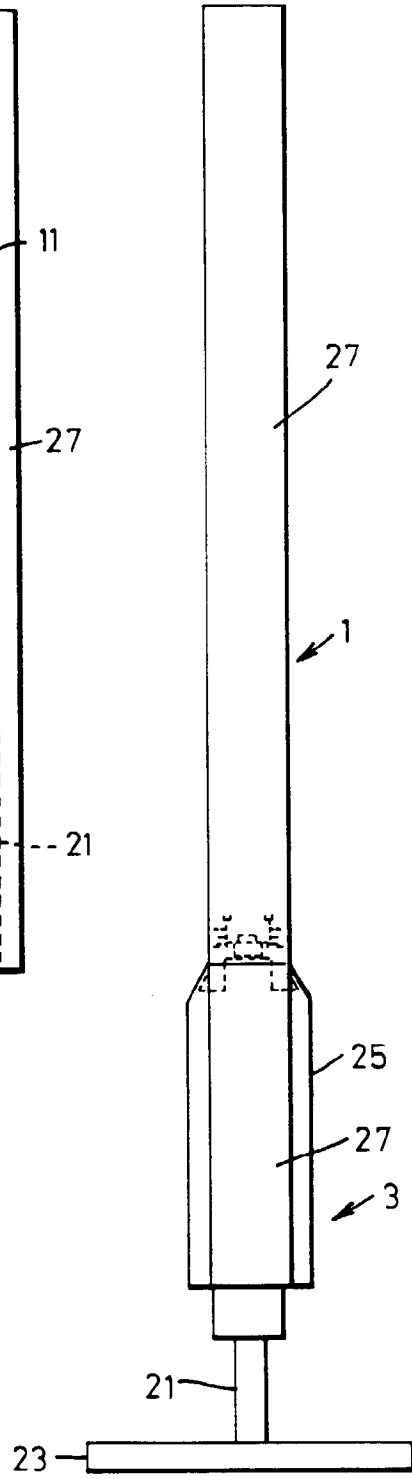

FIG. 3

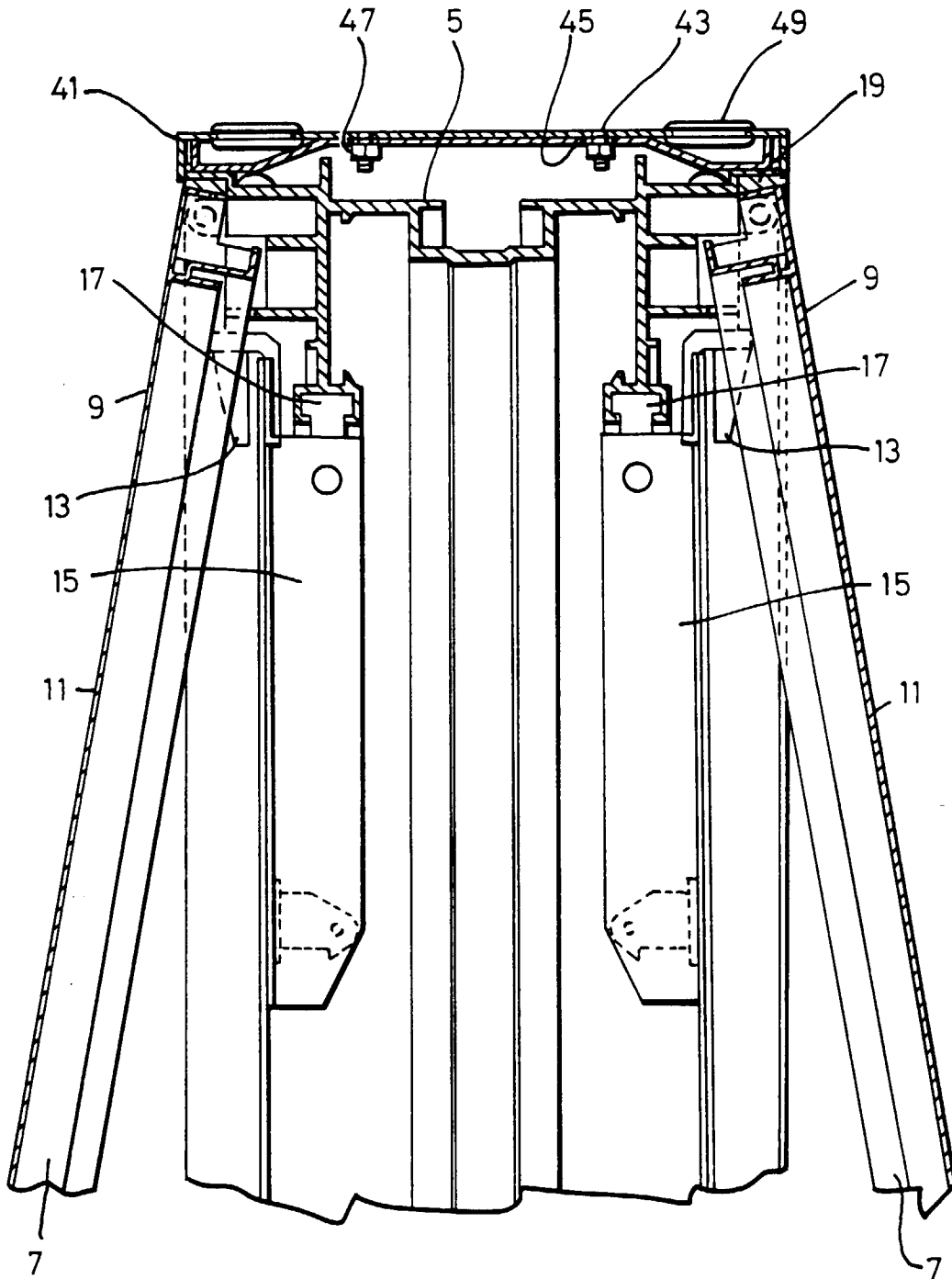

FIG. 4

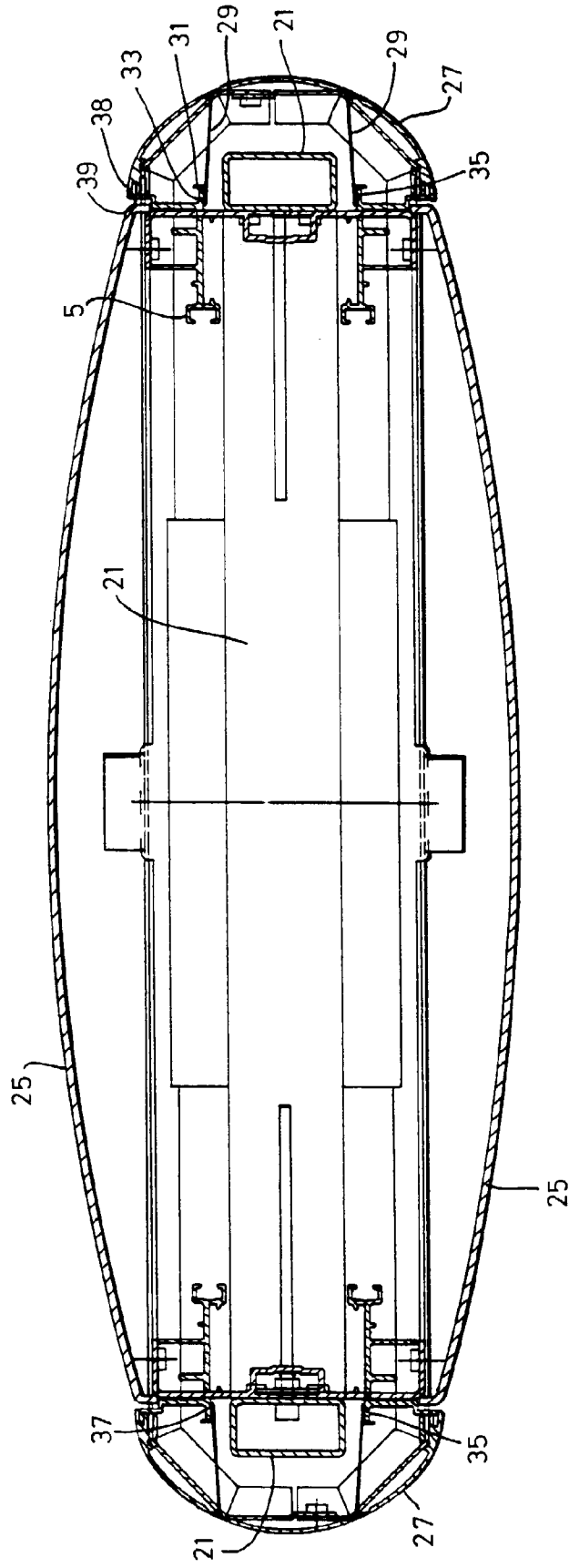

FIG. 5

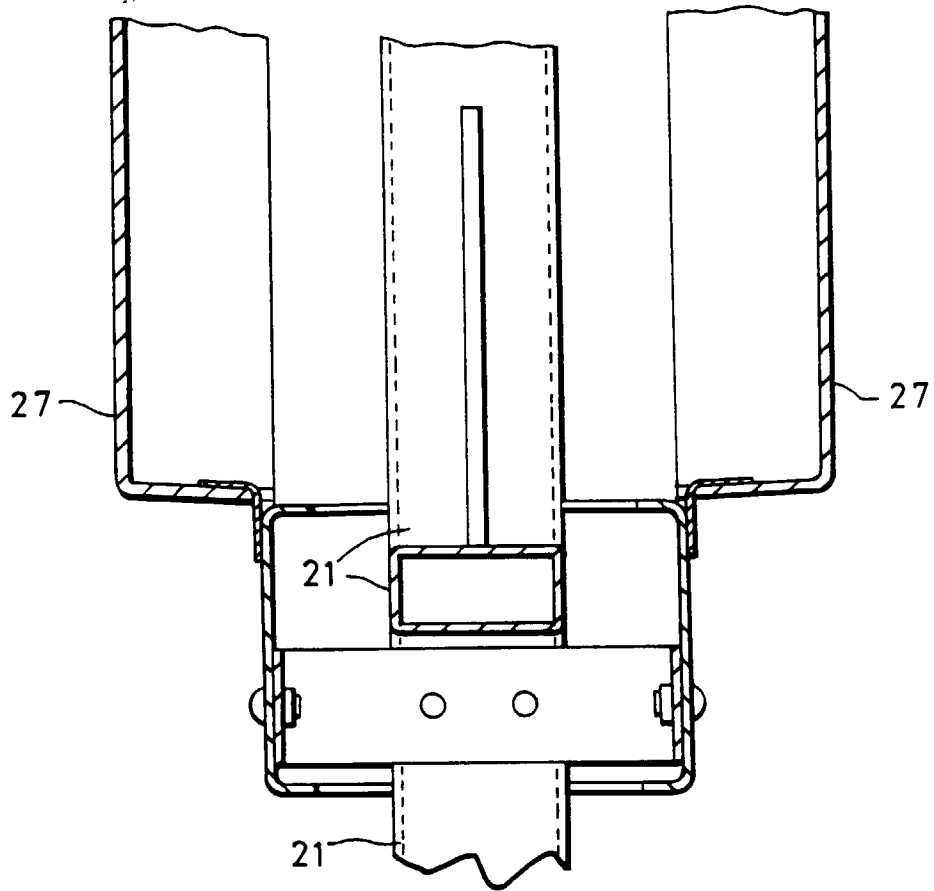

FIG. 6

