



Europäisches Patentamt  
European Patent Office  
Office européen des brevets



(11) **EP 0 694 223 B2**

(12) **NEW EUROPEAN PATENT SPECIFICATION**

(45) Date of publication and mention  
of the opposition decision:

**26.03.2003 Bulletin 2003/13**

(45) Mention of the grant of the patent:

**27.12.1996 Bulletin 1996/52**

(21) Application number: **94912311.1**

(22) Date of filing: **24.03.1994**

(51) Int Cl.7: **H01R 43/042**

(86) International application number:  
**PCT/US94/03268**

(87) International publication number:  
**WO 94/024733 (27.10.1994 Gazette 1994/24)**

(54) **TOOL FOR THE CONTEMPORARY CRIMPING OF A PLURALITY OF INSULATED WIRES IN AN ELECTRICAL CONNECTOR**

WERKZEUG ZUM GLEICHZEITIGEN VERPRESSEN EINER VIELZAHL VON ISOLIERTEN DRÄHTEN IN EINEM ELEKTRISCHEN VERBINDER

OUTIL PERMETTANT DE SERTIR EN MEME TEMPS UNE PLURALITE DE FILS ISOLES DANS UN DISPOSITIF DE RACCORDEMENT ELECTRIQUE

(84) Designated Contracting States:  
**BE DE FR GB GR IT**

(30) Priority: **14.04.1993 DE 9305607 U**

(43) Date of publication of application:  
**31.01.1996 Bulletin 1996/05**

(73) Proprietor: **MINNESOTA MINING AND  
MANUFACTURING COMPANY  
St. Paul, Minnesota 55133-3427 (US)**

(72) Inventors:

- **WURST, Wolfgang  
D-22049 Hamburg (DE)**
- **WOLTER, Eckhard  
D-88525 Duermentingen (DE)**

(74) Representative: **Patentanwälte  
Hauck, Graalfs, Wehnert, Döring, Siemons,  
Schildberg  
Neuer Wall 41  
20354 Hamburg (DE)**

(56) References cited:

<b>EP-A- 0 139 368</b>	<b>EP-A- 0 309 871</b>
<b>DE-A- 3 704 904</b>	<b>DE-C- 2 515 171</b>
<b>DE-U- 8 805 338</b>	<b>US-A- 3 354 692</b>
<b>US-A- 3 885 287</b>	<b>US-A- 3 972 101</b>

- **AMP Stack application hand tooling 1980**
- **AMP Stack application hand tooling 1992**
- **3 M hand tool for 10 pair connectors 1991**

**EP 0 694 223 B2**

**Description**

## BACKGROUND OF THE INVENTION

FIELD OF THE INVENTION:

**[0001]** The invention refers to a tool for the contemporary crimping of a plurality of insulated wires in an electrical connector.

PRIOR ART

**[0002]** Particularly in the telecommunication industry, electrical connectors have become known which are adapted to receive a multiplicity of insulated wires in order to terminate a plurality of electrical contacts. It is further known to establish the connection in that the connectors are provided with U-shaped insulation displacement contacts into which the wires are pressed. The insulation displacement contacts are located in a retaining body into which the individual wires are inserted. A pressing member or cover cooperates with the retaining body in order to press the individual wires contemporaneously into the U-shaped insulation displacement contacts.

**[0003]** Such connectors are for example disclosed by the German patent DE-C-39 20 367.

**[0004]** It is further known to accommodate such connectors in a splice head provided to facilitate the insertion of the wires into the connectors. Only when all wires are inserted and fixed, a pressing into the contact elements of the retaining body is carried out by means of the pressing member. Usually, this operation makes use of a corresponding pliers-like tool as for instance known from the German patent DE-C-25 15 171. The known tool includes legs which embrace the splice head on opposite sides and are attached thereto. A pressing member is located between the arms and can be moved by means of a manually operable lever and transmission means in order to press a plurality of wires into the retaining body which wires are also contemporarily cut. In this tool, the pressing force is built up and transmitted mechanically. From the European Patent Application EP-A-0.179 112 it is also known to exert the pressing force through hydraulic transmission means.

**[0005]** It is also known to provide the known connectors with plug contacts and plug contact strips. It is further known to stack two or more connectors one above the other. For this reason, the different combinations of connectors have different height. It is therefore necessary to consider the height of the different connectors when the wires are pressed and crimped. In case of hydraulically actuatable tools, this can be realized by a corresponding hydraulic control. Such tools, however, are relatively heavy and relatively difficult to handle. If manually operable, tools of less weight are desired, and usually each height of a connector necessitates another tool.

SUMMARY OF THE INVENTION

**[0006]** The invention provides for a tool according to the features of patent claim 1.

5 **[0007]** In the tool according to the invention, the pressing member is adapted to be displaced by predetermined steps relative to the housing independent from the transmission means. The actuation of the manual lever leads to a displacement of the pressing member relative to the splice head. This displacement, however, cannot be used for an adaptation to the height of the connector because a predetermined stroke is necessary in order to press the inserted wires fully into the contacts. At the end of such stroke, a locking means or other means are applied to avoid a further displacement of the pressing member. With a tool according to the invention, such a limitation of the stroke is also provided. By an adjustment of the position of the pressing member beforehand the stroke commences from different initial positions adapted to the actual height of the connector used at any one time.

10 **[0008]** Various structures can be conceived in order to realize a displacement of the pressing member step by step. One embodiment of the invention provides that at least an intermediate member is linked to the rear side of the pressing member rotatable about an axis. In different positions, the intermediate member coacts with a transmission lever actuated by the manual lever, with the pressing member having a different distance from the transmission lever in the individual rotational positions of the intermediate member. The intermediate member can for example be mounted on an eccentric member. The eccentric member can be actuated externally by a lever and for example effect two positions of the pressing member. According to another embodiment of the invention, the intermediate member has a plurality of recesses at the circumference thereof which may be engaged by a trunnion attached to the transmission lever, with the recesses having a different spacing from the rotation axis of the intermediate member. The number of displacement steps of the pressing member corresponds to the number of recesses. The latter embodiment is particularly suited for tools which attain an unambiguous fixed position relative to the splice head, i.e. cannot be displaced relative to the splice head.

15 **[0009]** The splice head can have teeth at opposite sides, and the tool has pivotally supported levers including also a tooth which coacts with the teeth of the splice head. The pitch of the teeth can be selected such that the spacing between two adjacent teeth corresponds to the difference in the height of the two different connectors. For connector combinations between these height values, an adaptation can be carried out by a displacement of the pressing member, e.g. by the described eccentric member.

25

30

35

40

45

50

55

### BRIEF DESCRIPTION OF THE DRAWINGS

**[0010]** The invention will be subsequently described by means of embodiment examples in connection with the accompanied drawings, wherein:

Fig. 1 is a plan view of a first embodiment of a tool according to the invention wherein the housing is partially removed, and Fig. 1A is a fragmentary detail view;

Fig. 2 is a plan view of a second embodiment of a tool according to the invention wherein also a part of the housing is removed;

Fig. 3 is a cross section through the tool of Fig. 2 taken along line 3-3;

Fig. 4 is a cross section through the tool of Fig. 2 taken along line 4-4;

Fig. 5 is a side view of the tool of Fig. 2 and of a connector with a first height;

Fig. 6 is an illustration similar to Fig. 5, however, with a connector having a second height;

Fig. 7 is an illustration similar to Fig. 5, however, with a connector having a third height; and

Fig. 8 is an illustration similar to Fig. 5, however, with a connector having a fourth height.

### DETAILED DESCRIPTION OF THE DRAWINGS

**[0011]** The tool 10 shown in Fig. 1 includes a housing 12 which is depicted partially opened. A first lever 14 is fixedly attached to the housing while a second actuation lever 16 is linked to housing 12 at 18. At the opposite end of the housing, two parallel spaced extensions 20, 22 are provided which cooperate with a splice head indicated at 24. An accommodation plate 26, or retaining member, of splice head 24 is shown onto which an electrical connector (not shown) can be placed. Plate 26 has recesses 28, 30 at opposite ends which are engaged by lower arms 32, 34 of levers 36, 38 by means of pins 40, 42 thereon in order to attach tool 10 to splice head 24. As separately shown in Fig. 1A, at the right side of Fig. 1, recesses 28, 30 are formed in bifurcated portions of plate 26; the pins 40, 42 thus are provided on opposite sides of lever arms 32, 34. The levers 36, 38 are pivotally supported on housing 12 and can be tilted clockwise and counter-clockwise, respectively, as indicated on the right side of Fig. 1 in order to engage and disengage with recesses 28, 30, with the levers 36, 38 biased by springs 44, 46 towards locking direction.

**[0012]** An elongated pressing member 50 which extends approximately parallel to accommodation plate 26 is linked to two sector-like intermediate members 56, 58 at 52, 54. The intermediate member 56, 58 can be rotated by a square neck 60, 62, for example by a suitable wrench so that various recesses 64, 68 at the circumference of the intermediate members 56, 58 may be engaged by trunnions 70, 72 of links 74, 76. The links 74, 76 are linked the transmission means, including a rack

82, at 78, 80 displaceably supported in housing 12 parallel to pressing member 50. The levers 74, 76 are further coupled by a connecting lever 84 which is coupled to pressing member 50 through a spring 86.

**[0013]** The rack 82 is moved parallel to the pressing member by a ratchet lever 88 having a toothed end linked to actuation lever 16. A spring-biased locking lever 90 also having teeth meshing with the teeth on the rack 82 in each position. By means of the described mechanism, the pressing member can be moved towards the accommodation plate 26 about a predetermined stroke length so that a connector on the accommodation plate 26 is pressed a predetermined amount in order to crimp the wires in the manner described above.

**[0014]** As can be seen, the individual recesses 64, 68 designated with a, b, c and d on the sector-like intermediate member, have a different spacing from rotation axis 52, 54 of intermediate member 56, 58. Therefore, the pressing member 50 has a different initial position when carrying out the described stroke in dependence of the recesses 64, 68 engaged by the trunnion 70, 72 of lever 74, 76. In this manner, an adjustment to the height of a connector can be achieved.

**[0015]** In the crimping operation described the pressing member 50 makes a predetermined stroke while a limitation of the stroke for example can be achieved by stop means cooperating with rack 82. If the crimping operation is finished, stop lever 90 is actuated so that rack 82 is moved back by the spring bias in the position shown in Fig. 1. In order to remove the connector, levers 36, 38 are tilted so that the tool 10 can be released from splice head 24. Thereafter, the connector can be removed from splice head 24.

**[0016]** The tool 100 shown in Fig. 2 includes a housing 102, an actuation lever 104 fixedly attached to housing 102 while a further actuation lever 106 is linked to housing 102 at 108. The housing 102 is depicted partially opened in order to more clearly show the transmission mechanism.

**[0017]** A splice head 110 has a retaining member in the form of an accommodation plate 112 for the accommodation of a connector not shown. On opposite sides of splice head 110 is a rack each having parallel teeth 114, 116. Levers 122, 124 are linked to opposite sides of housing 102 at 118, 120. One arm of the levers 122, 124 defines a handle 126, 128 while the other arm 130, 132 is also provided with teeth cooperating with the teeth 114, 116 of splice head 110. In accordance with the pitch of teeth 114, 116 or 130, 132, respectively, a predetermined spacing "h" of the pressing member 134 from the upper side of accommodation plate 112 can be adjusted.

**[0018]** As can be seen in Figs. 3 and 4, the pressing member 134 is U-shaped in cross section and linked to housing 102 by means of an eccentric bolt 136. By the way, the housing includes two opposite plates 138, 140. On one end, the eccentric bolt 136 is connected with a

hand lever 142 so that spacing "h" can be changed by a tilting of lever 142. The eccentric bolt 136 has an extension 144 linked to a gear segment 148 at 146 (see Fig. 2), with the gear segment 148 rotatably supported by housing 102 at 150. It includes a pinion 152 cooperating with a slot 154 of housing 102 indicated by dashed lines.

**[0019]** The transmission means for pressing the member 134 against the plate 112 includes a ratchet lever 156 which is linked to actuation lever 106 so that an actuation of lever 106 leads to a rotation of gear segment 148 counter-clockwise. A spring-biased locking lever 158 secures the position of the gear segment 148. Upon rotation of gear segment 148, pressing member 134 is moved downwardly in order to exert a force on a connector on accommodation plate 112. The stroke length of pressing member 134 is limited by the length of the arc of the gear segment 148.

**[0020]** In Figs. 5 to 8, a tool 100 is shown in connection with connectors v1 to v4 of different height accommodated by a splice head 110. The connectors v1 and v2 of Figs. 6 and 7 have a difference in height of for example 6 mm. The difference in height between the connectors v3 and v4 of Figs. 7 and 8 amount for example to 1,3 mm. As can be seen in Figs. 5 and 6 or 7 and 8, respectively, a tilting of hand lever 142 and thus a rotation of the eccentric bolt 136 about 180° results in a displacement of the pressing member 134 about 1,3 mm. The spacings between pressing member 134 and plate 112 in Figs. 5 and 6 are 10,1 and 11,4 mm, respectively, and regarding Figs. 7 and 8 16,1 and 17,4 mm. In the embodiment of figs. 5 and 6, the tothing of levers 122, 124 engages the lowest area of tothing 114, 116 of splice head 110. In the embodiment of Figs. 7 and 8, the engagement is offset about one tooth pitch. This corresponds to a change in the spacing between pressing member 134 and plate 112 in the amount of 6 mm. If lever 142 in Fig. 7 is tilted about 180° according to Fig. 8, pressing member 134 is lowered about 1,3 mm. The lowering of pressing member starts, however from a changed position which is about 6 mm higher than of Figs. 5 and 6.

**[0021]** In the manner described, connectors of four different heights can be handled by tool 100. If the tothing 114, 116 of levers 122, 124 engage the tothing of splice head 110 further upwardly, connectors with larger heights can be dealt with also.

**[0022]** It should be mentioned that pressing member 134 is biased by springs 160, 162 towards the eccentric bolt 136 in order to give the pressing member 134 a defined vibration-free position.

## Claims

1. A tool for the termination of a plurality of insulated wires in an electrical connector, comprising a splice head (24, 110) having a retaining body (26, 112),

and a pressing member (50, 134) accommodated by a housing (12, 102), said tool including attachment means (36, 38, 122, 124) for releasably attaching said housing (12, 102) to said splice head (24, 110), said pressing member (50, 134) cooperating with said connector accommodated by said splice head (24, 110), a pivotally supported, manually operable lever (16, 106) which acts on said pressing member (50, 134) through transmission means to move said pressing member (50, 134) relative to said housing in order to effect a predetermined stroke of said pressing member, **characterized in that** independent from said transmission means, said pressing member is adapted to be displaced by means (56, 58, 142, 136) affording displacement in predetermined steps relative to said splice head (24, 110) and said housing (12, 102), so that said pressing member (50, 134) can take different initial positions relative to said housing (12, 102) before said predetermined stroke commences.

2. The tool according to claim 1, wherein at least one intermediate member (56, 58, 136) is linked to the rear side of said pressing member, in different rotational positions said intermediate member coaxing with a transmission lever (74, 76, 144) actuated by said manually operable lever (16, 106), with said pressing member (50, 134) having a different spacing from said transmission lever (74, 76, 144) in said individual rotational positions of said intermediate member.
3. The tool of claim 2, wherein said intermediate member is defined by an eccentric member (136).
4. The tool of claim 2, wherein said intermediate member (56, 58) has a plurality of recesses (64, 68 at the circumference thereof which are engaged by a trunnion attached (70, 72) to said transmission lever, with said recesses having a different spacing from the rotation axis of said intermediate member.
5. The tool of claim 1, wherein on opposite sides said splice head (110) has a rack (114, 116) and levers (122, 124) pivotally supported by said tool have teeth cooperating with said rack of said splice head.
6. The tool of claim 5, wherein said levers (122, 124) are two-armed, with the other arm provided with a handle (126, 128).
7. The tool of claim 2, wherein displacement means on said splice head are provided to displace said splice head by steps and the extent of the spacing between said displacement steps of said intermediate member is smaller than the steps of said displacement means on said splice head.

8. The tool of claim 3, wherein displacement means on said splice head are provided to displace said splice head by steps and the extent of the spacing between said displacement steps of said intermediate member is smaller than the pitch of said displacement means on said splice head.
9. The tool of claim 2 and 5, wherein the extent of the spacing between said displacement steps of said intermediate member is smaller than the pitch of said teeth of said rack on said splice head.

#### Patentansprüche

1. Werkzeug zum Verpressen einer Vielzahl von isolierten Leitern in einem elektrischen Verbinder, umfassend einen Spleißkopf (24, 110) mit einem Trägerkörper (26, 112) und ein Preßglied, die von einem Gehäuse (12, 102) aufgenommen sind, wobei Festlegemittel (36, 38, 122, 124) zum lösbaren Festlegen des Gehäuses (12, 102) am Spleißkopf (24, 110) vorgesehen sind, wobei das Preßglied (50, 134) mit dem Verbinder zusammenwirkt, der im Spleißkopf (24, 110) aufgenommen ist, einem schwenkbar gelagerten Handhebel (16, 106), der über Getriebemittel auf das Preßglied (50, 134) wirkt, gegenüber dem Gehäuse zu bewegen, um einen vorgegebenen Hub des Preßgliedes (50, 134) zu bewirken, **dadurch gekennzeichnet, daß** das Preßglied (50, 134) durch Mittel (56, 58, 142, 136) unabhängig von den Getriebemitteln in vorgegebenen Stufen relativ zum Spleißkopf (24, 110) und dem Gehäuse (12, 102) verstellbar ist, so daß das Preßglied (50, 134) unterschiedliche Ausgangspositionen gegenüber dem Gehäuse (12, 102) annehmen kann, bevor der vorgegebene Hub beginnt.
2. Werkzeug nach Anspruch 1, **dadurch gekennzeichnet, daß** an der Rückseite des Preßglieds mindestens ein Zwischenglied (56, 58; 136) angeordnet ist, das in unterschiedlichen Drehstellungen mit einem vom Handhebel (16, 106) betätigbaren Getriebehebel (74, 76, 144) zusammenwirkt, wobei das Preßglied (50, 134) in einzelnen Drehstellungen des Zwischenglieds einen unterschiedlichen Abstand zum Getriebehebel (74, 76, 144) aufweist.
3. Werkzeug nach Anspruch 2, **dadurch gekennzeichnet, daß** das Zwischenglied ein Exzenter (136) ist.
4. Werkzeug nach Anspruch 2, **dadurch gekennzeichnet, daß** das Zwischenglied (56, 58) an seinem Umfang Ausnehmungen (64, 68) aufweist, in die ein Zapfen (70, 72) am Getriebehebel eingreift, wobei die Ausnehmungen einen unterschiedlichen Abstand zur Drehachse des Zwischenglieds auf-

weisen.

5. Werkzeug nach einem der Ansprüche 1, **gekennzeichnet, daß** der Spleißkopf (110) an gegenüberliegenden Seiten eine Zahnung (114, 116) aufweist und am Werkzeug mit einer Zahnung versehene schwenkbar gelagerte Hebel (122, 124) mit den Zahnungen am Spleißkopf zusammenwirken.
6. Werkzeug nach Anspruch 5, **dadurch gekennzeichnet, daß** die Hebel (122, 124) doppelarmig sind und der andere Arm mit einer Handhabe (126, 128) versehen ist.
7. Werkzeug nach Anspruch 2, **dadurch gekennzeichnet, daß** Verstellmittel am Spleißkopf vorgesehen sind, wobei das Maß des Abstands zwischen den Verstellstufen des Zwischenglieds kleiner ist als die Verstellstufen der Verstellmittel am Spleißkopf.
8. Werkzeug nach Anspruch 3, **dadurch gekennzeichnet, daß** Verstellmittel am Spleißkopf vorgesehen sind, wobei das Maß des Abstands zwischen den Verstellstufen des Zwischenglieds kleiner ist als die Teilung der Zahnung am Spleißkopf.
9. Werkzeug nach Anspruch 2 und 5, **dadurch gekennzeichnet, daß** das Maß des Abstands zwischen den Verstellstufen des Zwischenglieds kleiner ist als die Teilung der Zahnung am Spleißkopf.

#### Revendications

1. Outil pour la terminaison de plusieurs fils isolés dans un connecteur électrique, comportant une tête de branchement (24, 110) ayant un corps de retenue (26, 112), et un élément d'appui (50, 134) reçu par une boîte (12, 102), ledit outil comportant des moyens de fixation (36, 38, 122, 124) pour fixer de manière libérable ledit boîtier (12, 102) sur ladite tête de branchement (24, 110), ledit élément d'appui (50, 134) coopérant avec ledit connecteur reçu par ladite tête de branchement (24, 110), un levier pouvant être actionné manuellement (16, 106), supporté de manière pivotante, qui agit sur ledit élément d'appui (50, 134) par l'intermédiaire de moyens de transmission pour réaliser une course prédéterminée dudit élément d'appui, **caractérisé en ce qu'**indépendamment desdits moyens de transmission, ledit élément d'appui est adapté pour être déplacé par des moyens (56, 58, 142, 136) procurant un déplacement par étapes prédéterminées par rapport à ladite tête de branchement (24, 110) et ledit boîtier (12, 102), de sorte que ledit élément d'appui (50, 134) peut prendre différentes positions initiales par rapport audit boîtier (12, 102) avant que ladite cour-

se prédéterminée ne commence.

2. Outil selon la revendication 1, dans lequel au moins un élément intermédiaire (56, 58 ; 136) est articulé sur le côté arrière dudit élément d'appui, ledit élément intermédiaire coagissant dans différentes positions de rotation, avec un levier de transmission (74, 76 ; 144) actionné par ledit levier pouvant être actionné manuellement (16, 106), ledit élément d'appui (50, 134) ayant un espacement différent à partir dudit levier de transmission (74, 76 ; 144) dans lesdites positions de rotation individuelles dudit élément intermédiaire. 5  
10
3. Outil selon la revendication 2, dans lequel ledit élément intermédiaire est défini par un élément excentré (136). 15
4. Outil selon la revendication 2, dans lequel ledit élément intermédiaire (56, 58) a plusieurs cavités (64, 68) au niveau de sa circonférence, qui viennent en prise avec un tourillon (70, 72) fixé sur ledit levier de transmission, lesdites cavités ayant un espacement différent à partir dudit axe de rotation dudit élément intermédiaire. 20  
25
5. Outil selon la revendication 1, dans lequel sur ses côtés opposés ladite tête de branchement (110) a une crémaillère (114, 116), et des leviers (122, 124) supportés de manière pivotante par ledit outil ont des dents coopérant avec ladite crémaillère de ladite tête de branchement. 30
6. Outil selon la revendication 5, dans lequel lesdits leviers (122, 124) sont du type à deux bras, l'autre bras étant muni d'une poignée (126, 128). 35
7. Outil selon la revendication 2, dans lequel des moyens de déplacement sont agencés sur ladite tête de branchement et l'étendue de l'espacement existant entre lesdites étapes de déplacement dudit élément intermédiaire est plus petite que les étapes desdits moyens de déplacement situés sur ladite tête de branchement. 40  
45
8. Outil selon la revendication 3, dans lequel des moyens de déplacement sont agencés sur ladite tête de branchement et l'étendue de l'espacement existant entre lesdites étapes de déplacement dudit élément intermédiaire est plus petite que le pas desdits moyens de déplacement situés sur ladite tête de branchement. 50
9. Outil selon les revendications 2 et 5, dans lequel l'étendue de l'espacement existant entre lesdites étapes de déplacement dudit élément intermédiaire est plus petite que le pas desdites dents de ladite crémaillère située sur ladite tête de branchement. 55

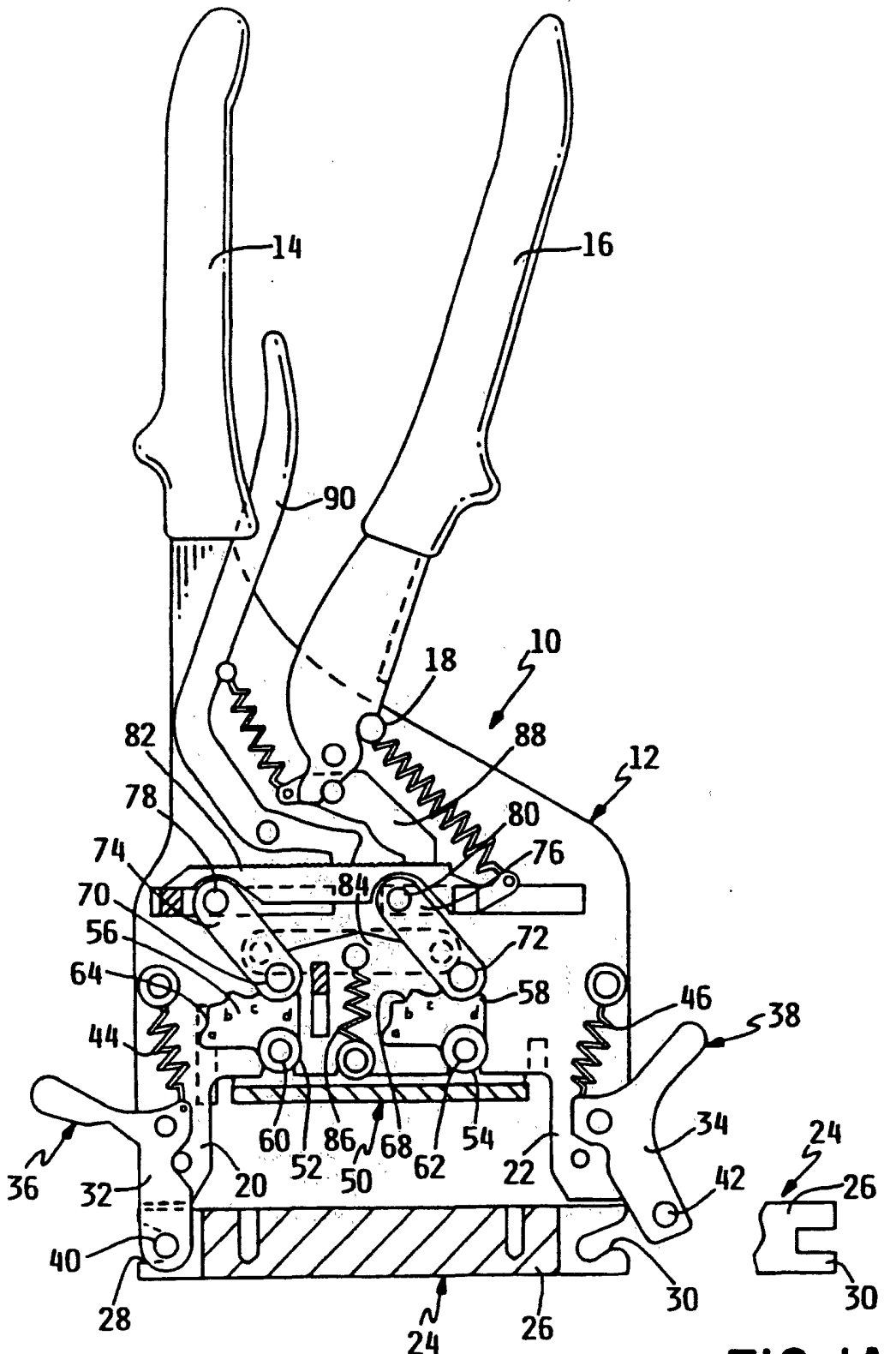

FIG. I

FIG. IA

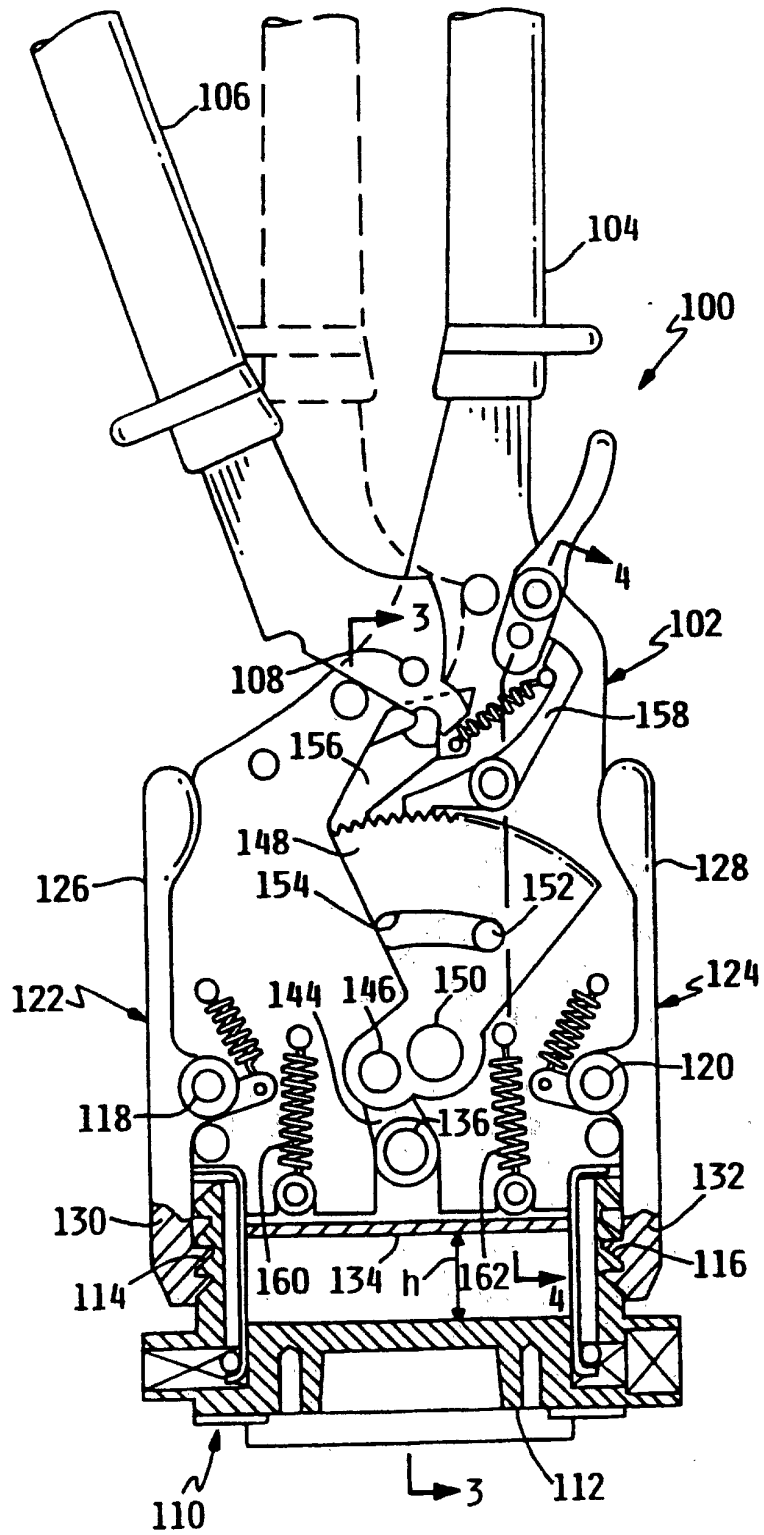

FIG. 2

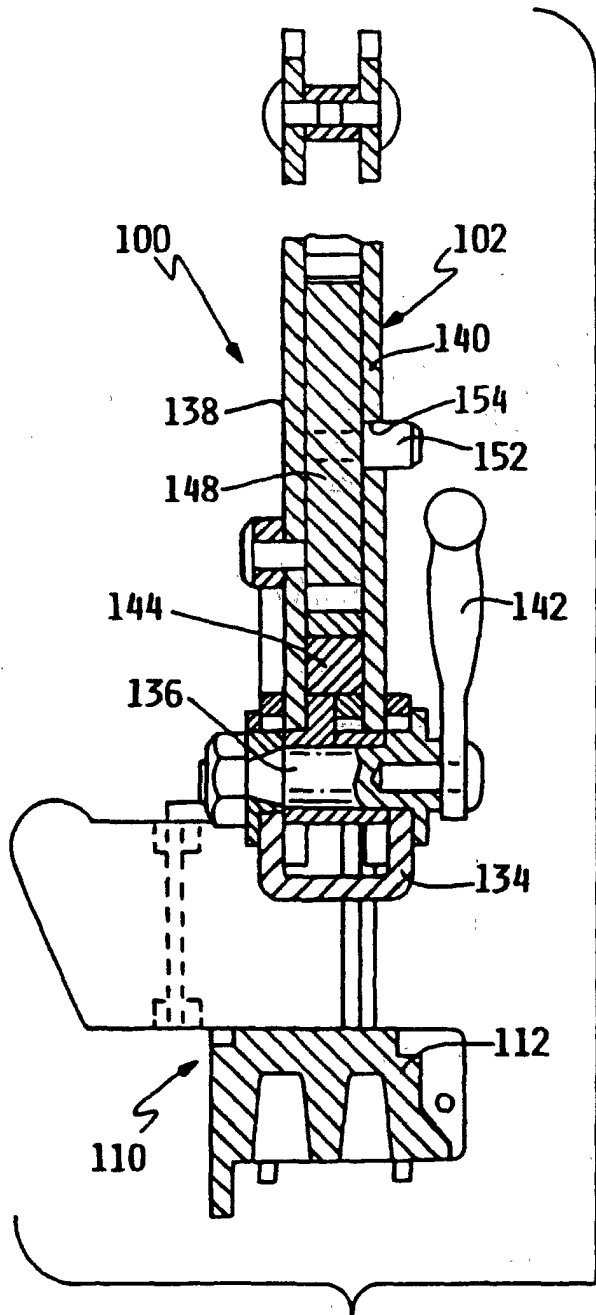

FIG. 3

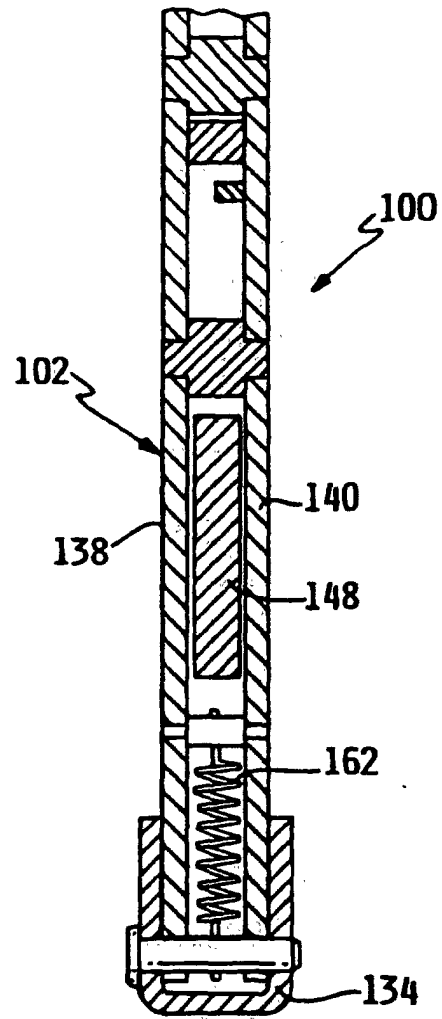

FIG. 4

