

(19)



Europäisches Patentamt  
European Patent Office  
Office européen des brevets



(11)

**EP 0 695 264 B1**

(12)

**EUROPEAN PATENT SPECIFICATION**

(45) Date of publication and mention of the grant of the patent:

**30.09.1998 Bulletin 1998/40**

(21) Application number: **94919103.5**

(22) Date of filing: **29.04.1994**

(51) Int Cl.<sup>6</sup>: **B65D 5/06**

(86) International application number:  
**PCT/US94/04739**

(87) International publication number:  
**WO 94/25352 (10.11.1994 Gazette 1994/25)**

(54) **IMPROVED OPENING SYSTEM FOR CONTAINERS**

VORRICHTUNG ZUM ERLEICHTERN DES ÖFFNENS FÜR BEHÄLTER

SYSTEME D'OUVERTURE AMELIORE POUR RECIPIENT

(84) Designated Contracting States:  
**AT BE CH DE DK ES FR GB GR IE IT LI LU NL PT SE**

(30) Priority: **01.05.1993 GB 9309079**  
**30.11.1993 EP 93870229**

(43) Date of publication of application:  
**07.02.1996 Bulletin 1996/06**

(73) Proprietor: **THE PROCTER & GAMBLE COMPANY**  
**Cincinnati, Ohio 45202 (US)**

(72) Inventors:  
• **DECALUWE, Robert, Corneel**  
**B-2910 Londerzeel (BE)**  
• **DEFLANDER, Joseph, Fernand**  
**B-3150 Wespelaar (BE)**  
• **TACK, Joris, Jozef, Gustaaf**  
**B-3140 Keerbergen (BE)**

• **VERHELLE, Christian**  
**B-2800 Mechelen (BE)**  
• **MCKEE, Alan James**  
**Brompton, North Yorkshire DL6 2PY (GB)**

(74) Representative: **Engisch, Gautier et al**  
**Procter & Gamble**  
**European Technical Center N.V.**  
**Temseleaan 100**  
**1853 Strombeek-Bever (BE)**

(56) References cited:  
**EP-A- 0 083 441**                      **EP-A- 0 087 839**  
**EP-A- 0 185 325**                      **EP-A- 0 286 313**  
**WO-A-82/03370**                      **DE-A- 2 650 092**  
**GB-A- 2 146 624**                      **GB-A- 2 253 608**  
**US-A- 2 172 930**                      **US-A- 3 520 464**  
**US-A- 4 821 950**                      **US-A- 4 874 126**  
**US-A- 4 883 222**

**EP 0 695 264 B1**

Note: Within nine months from the publication of the mention of the grant of the European patent, any person may give notice to the European Patent Office of opposition to the European patent granted. Notice of opposition shall be filed in a written reasoned statement. It shall not be deemed to have been filed until the opposition fee has been paid. (Art. 99(1) European Patent Convention).

## Description

### Technical field

The invention relates to containers comprising a body with a bottom at a first end of said body and a pouring spout which is formed upon opening of a folded sealed top portion at a second end of said body. The containers of the present invention comprise a pulling device affixed to part of said folded sealed top portion which upon opening forms a pouring spout.

### Background of the invention

Containers are known to be constructed from pre-fabricated blanks which have a suitable arrangement of fold lines which facilitate folding up and forming the container, by folding into their definitive positions the panels or areas which form the upper portion and the bottom. The container blanks are mostly coated with a thermoplastic material, for example polyethylene, which is used both to make the container liquid-tight and also to seal the container using heat and pressure so that it is correctly folded and sealed in its erected position. Such container known in the art may be a gable topped container slanted or not slanted or a flat topped container.

For example, containers which have a gable-like closure on their top are for instance described in GB 2,146,624 of Tetra Pak International AB which discloses a container of this kind comprising one or more pressure equalizing openings placed at the upper part of the container. EP 286,313 of Minnesota Mining also discloses a gable-top sealable thermoplastic coated container having stiffening fillets secured to gable rib panels or roof rib panels to facilitate opening without tearing or delamination.

Furthermore, in the art some containers have been developed having different sealing means in the folded sealed top portion. Indeed, some seams are provided in said folded sealed top portion which have a substantial adhesive force in order to keep the container liquid-tight during transportation and prior to opening thereof while other seams at least in part have a low level of adhesive force allowing thereby an easier opening of said folded sealed portion in such a way as to form a pouring spout for satisfactorily pouring out the contents of the container.

There are various methods known of producing sealing seams with a low level of adhesive force. For instance, the regions which are to have a low level of adhesive force could be coated with a suitable adhesive coating such as a wax-based material or silicone rubber. Said regions can also be coated with a special plastic material which has a higher sealing temperature than the remaining thermoplastic material. When then the sealing operation is carried out at a lower temperature, the regions with a low adhesive force are in turn produced in the desired manner in the regions which have

the special plastic material with a higher sealing temperature. There are also various configurations known with regard to the pouring spout formed by the sealing area with the low adhesive force characteristics. Said sealing area could be formed by a pattern of raised surfaces which alternate with areas which are disposed therebeside and at a lower level. Representative of this art is for example EP 185,325 of Tetra Pak International AB which discloses a package made of a supporting material such as cardboard, coated with a thermoplastic material, for liquids or the like, comprising a tubular main body with a base and a cover which is folded into a ridge shape and has a pouring spout which can be opened by opening sealed seams, wherein the sealing region of the spout contains sealing sections with strong adhesive power and adjacent sections with low adhesive power for peeling the sealing sections apart, and wherein the sealing section with low adhesive power is formed by a pattern of raised surfaces at a spacing from one another, alternating with adjacent sections at a lower level, wherein the region with low adhesive power extends into the ridge area and into the lateral triangular sections of the ridge. Areas with low adhesive power are so-called adhesive pads.

Furthermore, it is well known that the consumer wants a sealing seam which can be easily opened, at at least one location on the cover. Unfortunately, the existing containers still have a sealing seam which appears to be a problem for the consumer to open the container. The existing containers have to be opened by means of 2 consecutive actions (1) the wings of the top panel have to be moved outwards completely, breaking the top seal; and (2) upon pushing onto the ends of the wings the pour spout is formed. In particular the second movement is not easily understood and done by consumers. Also this operation frequently results in embarrassing spillage, often with damage to the clothing of the user. Such difficulty in opening the existing containers can be due to the necessary adhesion at the sealed margins, or to incorrect positioning of the adhesive pads. Other examples of containers that have to be opened by means of 2 consecutive actions comprise containers disclosed in GB 2 253 608 and US 4 821 950. Another disadvantage of the known containers is that the cardboard of the container creases which results in lowering the stiffness of the container. Lower stiffness may also lead to spillage due to partial removal of a multilayer by acting on the pulling device disclosed in DE-2 650 092.

It is therefore an object of the present invention to provide a container suitable to contain a fluid having a folded sealed top portion easily openable which, upon opening, forms a pouring spout.

It is a further object of the present invention to provide a container for which the second action for its opening as mentioned above is a more natural one and is less dependent on the quality of the adhesive pads if present, and/or on the reduced stiffness from the cardboard and/or on the understanding of the movements

required to open the container.

It has now been found that these objects can be efficiently met by affixing a pulling device to part of the folded sealed top portion of a container which upon opening forms a pouring spout. In other words it has been found that the addition of a physical and visual element aids to open containers in a much easier way, this by applying the pulling device to the part which in classic containers is pushed outwards. The new pulling device allows for a more natural action i.e. pulling versus pushing while all advantages of the container itself remain while one of the most important negatives is eliminated.

An additional advantage using the present invention is that the quality of the adhesive pads if present, is less critical and that less thick board with lower stiffness can be used, as opening is less dependent on said stiffness.

#### Summary of the invention

The present invention is a container comprising a container body, a bottom at a first end of the body and a folded sealed top portion at a second end of the body, said folded sealed top portion comprising means for its opening so as to form a pouring spout characterized in that said opening means comprise a pulling device affixed to part of said folded sealed top portion, and to the inner face of said top margins (68), said pulling device extending downwardly when the container is prepared for use.

#### Detailed description

The containers according to the present invention comprise a container body, a bottom at a first end of the body and a folded sealed top portion at a second end of the body. Said sealed top portion from which a pouring spout is formed upon opening comprises a front and a rear portion and a side portion which is inwardly folded to form a main triangular portion with two further smaller triangular portions folded towards said main triangular portion. The top margins of said side portion being sealed with the top margins of the front and rear portions to close the top in a liquid tight manner. The margin portions are then generally folded to lie in horizontal plane to facilitate stacking.

The base portions of the carton are folded in a somewhat similar manner to provide a sealed, fluid-tight flat base.

The main feature of the present invention is that said folded sealed top portion comprises opening means for opening said top portion so as to form a pouring spout. Said opening means comprise a pulling device affixed to part of said top portion inwardly folded, generally in the region of said main triangular portion. Once said top portion has been raised from its sealed position to provide wings, the pulling device of the

present invention helps to pull said top portion outwardly so as to peel the top margins of the side portion away from sealing relationship with the top margins of the front and the rear portions. This action provides a spout from which the fluid contained in the container may be poured or, if desired, drunk directly from said container.

The pulling device is affixed generally in the region of said main triangular portion. By "region of said main triangular portion" it is to be understood herein the sealed top portion as defined herein which is unfolded upon opening the pouring spout, i.e. the pouring spout forming package portion.

The pulling device can be affixed to the top margins of the side portion in said region of said main triangular portion, preferably at the center of said top margins, on either the inner face or outer face or both faces. The pulling device may also be affixed either to said main triangular portion below said top margins in said region of said triangular portion or to one or both of said further triangular portions below said top margins in said region of said triangular portion. Actually, any combinations is possible. However preferred herein the pulling device is positioned at a height allowing for container opening with minimal pull strength. This position is normally as high as possible but depending on the roof angle.

In closed container position the pulling device is folded in between the front and rear portions. Upon folding the wings, the pulling device becomes clearly visible, and pulling action opens the container. However the pulling device can also extend the limits of the closed container and thus be visible before having moved the wings outwardly. Whereas previously one had to push onto the ends of the unfolded wings, a simpler pulling action opens the pour spout. So the consumer will immediately understand how to open the container.

The pulling device according to the present invention can be any device of any shape or size which would facilitate such an opening operation. In one embodiment of the present invention, said pulling device is a tab, ring or tape sealed or glued or coated to part of said folded sealed top portion. In another embodiment the pulling device is made integrally with the carton blank. In a further embodiment of the present invention the pulling device is composed of a carrier with a self adhesive layer. Said carrier can be made of any kind of material like paper, carton, cotton, plastic, metal, alufoil and the like.

The pulling device according to the present invention can be composed of any kind of material but is preferably composed of a laminate. The laminate can be a low density polyethylene (LDPE) layer with a high density polyethylene, or LDPE with a polyester, or LDPE with a Nylon, or LDPE with polypropylene, or LDPE with a paper carrier. The laminate can also be constructed by forming a coextruded low density polyethylene/ high density polyethylene/ low density polyethylene layer wherein the polyethylene layer is sealed to the outer polyethylene of the lowered part of said surface. The sealing to the cardboard can be performed for instance by

heating or ultrasonic treatment, e.g. high frequency current.

The pulling device can be composed of a pressure sensitive material having a glue and a carrier sustaining the tearing activity e.g. Scotchband tape from 3M.

In one embodiment of the present invention the container front and rear portions can as a variation contain one or more score lines which, upon opening of the carton, act as part of the pour spout, and allow for easier pouring from the carton.

In another embodiment of the present invention the top margins comprise areas of low adhesive force and high adhesive force, said areas of low adhesive force (adhesive pads) being said seal between said front and rear portions and said side portion, as well as said seal between said folded portions of said side portion in said two triangular portions.

In order to allow for the use of a light-weight card in the construction of the container, in one embodiment of the present invention, a reinforcing band is provided encircling the girth of the container. Alternatively, the band may be affixed to the inner surface of the container. The band provides reinforcement to counter any bursting effect imposed by the weight of the contents.

The containers according to the present invention can be used for packaging all kinds of liquids which must be poured out preferably without spilling the contents of the container. Liquids to be packaged are for instance milk, beverages, oil, fabric softeners, household cleaners, dishwashing products or the like.

In the following description one form of the containers of the present invention is given by way of an example from which further advantages, features and possible uses will be apparent with reference to the accompanying drawings in which:

Fig. 1. is a plan view of a carton blank or flat according to the present invention.

Fig. 2. is a perspective view of a carton according to the present invention assembled in preparation for filling with the liquid content.

Fig. 3. shows the same carton as shown in Fig. 2, but filled and sealed.

Fig. 4. shows the same container as in Fig. 2 and/or 3, filled, and in a first stage of opening.

Fig. 5. shows the same container as in Fig. 4 in a second stage of opening.

Fig. 6. shows the same container as in Fig. 5 in a third stage of opening.

Fig. 7. is a view of a carton according to the present invention provided with a reinforcement band around its girth.

As seen in Figure 1 a carton blank 2 comprises a sheet of paper-board coated on each of its two sides with thermoplastic. The blank is provided with score lines 4, 6, 8 and 10 to define front and rear panels 12 and 14 respectively and left and right-hand panels 16 and 18 respectively and a joining strip 20.

A transverse score line 22 defines the upper limit of

the panels 12, 14, 16, 18 and a further transverse score line 24 defines the lower limit of the panels.

Above the score lines 22 are located upper closure portions 26, 28, 30 and 32, and below the score lines 24 are located lower closure portions 34, 36, 38 and 40. The joining flap 20 extends above and below the score lines 22 and 24.

The lower closure portion 36 has score lines 42 which define triangular areas 44 and 44A. Similarly, the lower closure portion 40 has score lines 46 which define triangular areas 48 and 48A.

The lower closure panel 34 extends somewhat further from the score line 24 than do the panels 36, 38 and 40, the extension being indicated at 34A in Figure 1.

A transverse score line 50 extends across the upper closure portions 26, 28, 30 and 32 to define an intermediate area 52. The intermediate area above panel 16 has diagonal score lines 54 defining triangular areas 56 and 56A, and the intermediate area 52 above the panel 18 has diagonal score lines 58 defining triangular areas 60 and 60A.

Further diagonal score lines 62 and 64 are formed in the intermediate area 52 above the panels 12 and 14 respectively defining triangular areas 62A and 64A respectively.

Above the intermediate area and the transverse score line 50 are rectangular areas 66, 68, 70 and 72 above the panels 12, 16, 14 and 18 respectively and vertical score lines 74 and 76 bisect the rectangular areas 68 and 72.

Above the area 66 extends a sealing strip 75 and a similar strip 77 extends above the area 70. A score line 78 extends transversely between the area 66 and the strip 75; a similar score line 80 extends between the area 70 and the strip 77. Extending from the strip 75 to the right as seen in Figure 1 is a tab 82 and a similar tab 84 extends from the top portion of the strip 20 to the left as seen in Figure 1.

A pull tab 86 is affixed to the inner face of the area 68 as indicated at 88 in Figure 1 and when the carton is prepared for use extends downwardly against the outer face of the areas 68 and 56 as seen clearly in Figures 2 and 5. The pull tab is made of a sandwich of a polyester with a low density polyethylene coating. The high density core of the material provides the strength necessary for the operation which it is intended to perform and the lower density coating enables its upper end portion to be secured in place by heat sealing to the coating on the inner surface of the carton.

The carton is prepared in readiness for filling with the liquid content by folding the blank 2 along its vertical score lines 4, 6, 8 and 10, and the joining strip 20 is heat sealed to the inner margin of the panels 12, 34 and intermediate area 52, as shown clearly in Figure 2.

The lower closure portions 36 and 40 are next folded inwardly about their diagonal score lines 42 and 46, and the score lines 4, 6, 8 and 10, the inwardly folded triangular areas 44A and 48A being heat sealed to the

triangular areas 44 and 48 respectively. Complete fluid-tight sealing of the bottom of the box is ensured as the extension 34A overlaps the edge of the rectangular area 38, as seen particularly in Figure 2, and is heat sealed thereto.

The thus formed and sealed carton is then filled with the desired fluid, e.g. milk or fruit juice, and the top of the carton is closed as follows.

The upper portions 28 and 32 of sides 16 and 18 are pushed inwardly to cause inward folding along the score lines 54 and 74 of the portions 28 and score lines 58 and 76 of the portion 32. The first part of such a folding sequence is seen clearly in Figure 2. Further pushing of those upper portions in an inward direction and downward depression of the portions 52 of the panels 12 and 14 causes the areas 66 and 70 to approach each other, sandwiching the areas 68 and 72 between them. The outer surfaces of the areas 68 and 72 also lie in contact with each other and the tabs 82 and 84 are folded around the outer surface of the strip 77.

The areas 66 and 70, the areas 68 and 72, and the strips 75 and 77 are then pressed firmly together between heated clamping jaws to effect heat sealing of the contacting surfaces.

The upstanding portions 66, 78 and 70, 76 seen in Figure 4 are then folded over to lie flat over the surface of the carton as seen clearly in Figure 3.

In order to open the carton to gain access to the contents, the folded-over portions 66, 78 and 70, 76 are first raised to revert to the position seen in Figure 4 and the tab 82 is unpeeled from around the end portion of the strip 75.

The user next applies pressure of the thumbs to the triangular areas 56A to cause separation of the inner surfaces of the areas 68 and the inner surfaces of the strips 75 and 77. The thus folded-back area 28, including the triangular areas 56, 56A, rectangular area 68 and strips 75, 77 lie on a plane which is normal to the transverse median line X as seen in Figure 5.

The pull tab 86 is then firmly grasped between a finger and thumb of one hand whilst the carton is held by the other hand. Pulling of the tab 86 in a direction away from the carton separates the inner surfaces of the areas 68 and 70, and continued pulling causes the portion 28 to bend about its score lines 22, 54 and 74 to form a spout 88 as seen clearly in Figure 6. Tab 86 is removed from its adhesive connection with the inner face of the area 68 by simply pulling it away therefrom.

With a carton of this construction it is thus found that ready access to the contents is achieved with little or no danger of spillage.

The contacting inner faces of the portions 66 and 70, and the strips 75 and 77 which are intended to remain in sealed relationship, after opening as described, are heat sealed together.

Those areas which are to be peeled apart in order to form the spout 88 are coated with an adhesive in order to prevent complete bonding between the faces of those

areas.

In order to allow for the use of a light-weight card in the construction of the carton, a reinforcing band 90 is provided encircling the girth of the carton as seen in Figure 7.

Whilst the specific example described refers to a flat topped carton, the same principle of the invention may be applied to so-called gable-topped cartons and slant-top cartons, well-known themselves in the packaging industry. In both of those alternative arrangements a pull tab 86 may be attached to part of the "spout" element of the carton to assist in opening with a reduced element of risk of spillage.

## Claims

1. A container comprising a container body, a bottom at a first end of the body and a folded sealed top portion at a second end of the body, said folded sealed top portion comprising a side portion having top margins (68) and further comprising means for its opening so as to form a pouring spout characterized in that said opening means comprise a pulling device (86) affixed to part of said folded sealed portion, and to the inner face of said top margins (68), said pulling device extending downwardly when the container is prepared for use.
2. A container according to claim 1 wherein said pouring spout is formed upon opening of said folded sealed top portion comprising a front and a rear portion and the side portion inwardly folded to form a main triangular portion (56) with two further triangular portions (56A) folded towards said main triangular portion (56), the top margins (68) of said side portion being sealed with the top margins (66,75 and 70,77) of the front and rear portion to close the top in a liquid tight manner, and the top margins (68) of said side portion in said two triangular portions (56A) are sealed together and said pulling device (86) is generally affixed in the region of said main triangular portion.
3. A container according to claim 2 wherein said pulling device (86) is affixed to the top margins (68) of said side portion in said region of said main triangular portion, preferably at the center of said top margins (68).
4. A container according to claim 3 wherein said pulling device (86) is in said region of said main triangular portion, or to the outer face of said top margins (68) or to both.
5. A container according to any of the claims 2 to 4 wherein said pulling device (86) is affixed to said main triangular portion (56) below said top margins

(68) in said region of said main triangular portion.

6. A container according to any of the claims 2 to 5 wherein said pulling device (86) is affixed to one or both of said further triangular portions (56A) below said top margins (68) in said region of said main triangular portion.
7. A container according to any of the claims 2 to 6 wherein said top margins comprise areas of high adhesive force and low adhesive force, said areas of low adhesive force being said seal between said front and rear portions and said side portion, as well as said seal between said folded portions of said side portion in said two triangular portions.
8. A container according to any of the preceding claims wherein said pulling device (86) is a tab, ring or tape sealed or glued or coated.

#### Patentansprüche

1. Behälter mit einem Behälterkörper, einem Boden an einem ersten Ende des Körpers und einem gefalteten, versiegelten Oberteil an einem zweiten Ende des Körpers, welcher gefaltete versiegelte Oberteil einen Seitenabschnitt mit oberen Rändern (68) sowie Mittel zum Öffnen desselben umfaßt, um eine Ausgießtülle zu bilden, dadurch gekennzeichnet, daß die Öffnungsmittel eine Zieheinrichtung (86) umfassen, die an einem Teil des gefalteten versiegelten Oberteiles und an der Innenseite der genannten oberen Ränder (68) befestigt ist, wobei sich die Zieheinrichtung nach unten erstreckt, wenn der Behälter zur Verwendung bereit ist.
2. Behälter nach Anspruch 1, bei welchem die Ausgießtülle durch Öffnen des gefalteten versiegelten Oberteiles gebildet wird, der einen vorderen und einen hinteren Abschnitt und den Seitenabschnitt umfaßt, der nach innen gefaltet ist, um einen dreieckigen Hauptabschnitt (56) mit zwei weiteren, in Richtung auf den dreieckigen Hauptabschnitt (56) gefalteten dreieckigen Abschnitten (56A) zu bilden, wobei die oberen Ränder (68) des Seitenabschnittes mit den oberen Rändern (66, 75 und 70, 77) des vorderen und hinteren Abschnittes versiegelt sind, um den Oberteil flüssigkeitsdicht zu verschließen, und wobei die oberen Ränder (68) des Seitenabschnittes in den beiden dreieckigen Abschnitten (56A) miteinander versiegelt sind und die Zieheinrichtung (86) im Bereich des dreieckigen Hauptabschnittes allgemein befestigt ist.
3. Behälter nach Anspruch 2, bei welchem die Zieheinrichtung (86) an den oberen Rändern (68) des Seitenabschnittes im Bereich des dreieckigen

Hauptabschnittes befestigt ist, bevorzugt in der Mitte der oberen Ränder (68).

4. Behälter nach Anspruch 3, bei welchem die Zieheinrichtung (86) im Bereich des dreieckigen Hauptabschnittes oder an der Außenseite der oberen Ränder (68), oder beides, befestigt ist.
5. Behälter nach einem der Ansprüche 2 bis 4, bei welchem die Zieheinrichtung (86) am dreieckigen Hauptabschnitt (56) unterhalb der oberen Ränder (68) im Bereich des dreieckigen Hauptabschnittes befestigt ist.
6. Behälter nach einem der Ansprüche 2 bis 5, bei welchem die Zieheinrichtung (86) an einem oder beiden der weiteren dreieckigen Abschnitte (56A) unterhalb der oberen Ränder (68) im Bereich des dreieckigen Hauptabschnittes befestigt ist.
7. Behälter nach einem der Ansprüche 2 bis 6, bei welchem die oberen Ränder Bereiche hoher Haftkraft und geringer Haftkraft aufweisen, wobei die Bereiche geringer Haftkraft die Dichtung zwischen den vorderen und hinteren Abschnitten und dem genannten Seitenabschnitt darstellen, sowie die Dichtung zwischen den genannten gefalteten Abschnitten des Seitenabschnittes in den beiden dreieckigen Abschnitten.
8. Behälter nach einem der vorhergehenden Ansprüche, bei welchem die Zieheinrichtung (86) eine Lasche, ein Ring oder ein Band ist, versiegelt, verklebt oder beschichtet.

#### Revendications

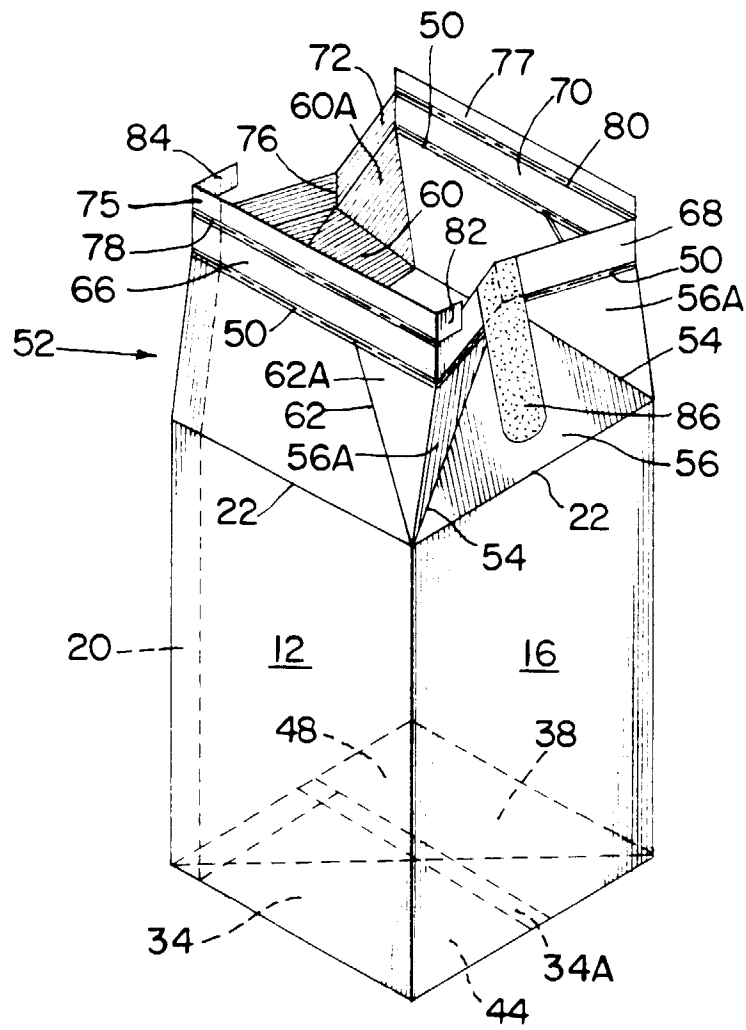
1. Récipient comprenant un corps de récipient, un fond à une première extrémité du corps et une portion supérieure scellée et pliée à une seconde extrémité du corps, ladite portion supérieure scellée et pliée comprenant une partie latérale ayant des bords supérieurs (68) et comprenant en outre un moyen permettant son ouverture de façon à former un bec-verseur, caractérisé en ce que ledit moyen d'ouverture comprend un dispositif de tirage (86) fixé à une partie de ladite portion supérieure scellée et pliée, et à la face intérieure desdits bords supérieurs (68), ledit dispositif de tirage s'étendant vers le bas lorsque le récipient est prêt à l'usage.
2. Récipient selon la revendication 1, dans lequel ledit bec-verseur est formé lors de l'ouverture de ladite portion supérieure scellée et pliée, comprenant une partie avant et une partie arrière et la partie latérale qui est pliée vers l'intérieur pour former une portion triangulaire principale (56) avec deux autres parties

- triangulaires (56A) pliées vers ladite partie triangulaire principale (56), les bords supérieurs (68) de ladite partie latérale étant scellés aux bords supérieurs (66, 75 et 70, 77) des parties avant et arrière pour fermer la portion supérieure d'une manière étanche aux liquides, et les bords supérieurs (68) de ladite partie latérale, dans les deux parties triangulaires (56A), sont scellés ensemble, et ledit dispositif de tirage (86) est généralement fixé dans la région de ladite partie triangulaire principale. 5  
10
3. Récipient selon la revendication 2, dans lequel ledit dispositif de tirage (86) est fixé aux bords supérieurs (68) de ladite partie latérale, dans ladite région de ladite partie triangulaire principale, de préférence au centre desdits bords supérieurs (68). 15
4. Récipient selon la revendication 3, dans lequel ledit dispositif de tirage (86) est fixé dans ladite région de ladite partie triangulaire principale, ou à la face extérieure desdits bords supérieurs (68), ou bien aux deux. 20
5. Récipient selon l'une quelconque des revendications 2 à 4, dans lequel ledit dispositif de tirage (86) est fixé à ladite partie triangulaire principale (56), en dessous desdits bords supérieurs (68) dans ladite région de ladite partie triangulaire principale. 25
6. Récipient selon l'une quelconque des revendications 2 à 5, dans lequel ledit dispositif de tirage (86) est fixé à l'une ou aux deux desdites autres parties triangulaires (56A), en dessous desdits bords supérieurs (68), dans ladite région de ladite partie triangulaire principale. 30  
35
7. Récipient selon l'une quelconque des revendications 2 à 6, dans lequel lesdits bords supérieurs comprennent des zones de grande adhésivité et de faible adhésivité, lesdites zones de faible adhésivité étant ledit joint entre lesdites parties avant et arrière et ladite partie latérale, ainsi que le joint entre lesdites parties pliées de ladite partie latérale dans lesdites deux parties triangulaires. 40  
45
8. Récipient selon l'une quelconque des revendications précédentes, dans lequel ledit dispositif de tirage (86) est une patte, un anneau ou une bande scellée ou collée ou revêtue. 50

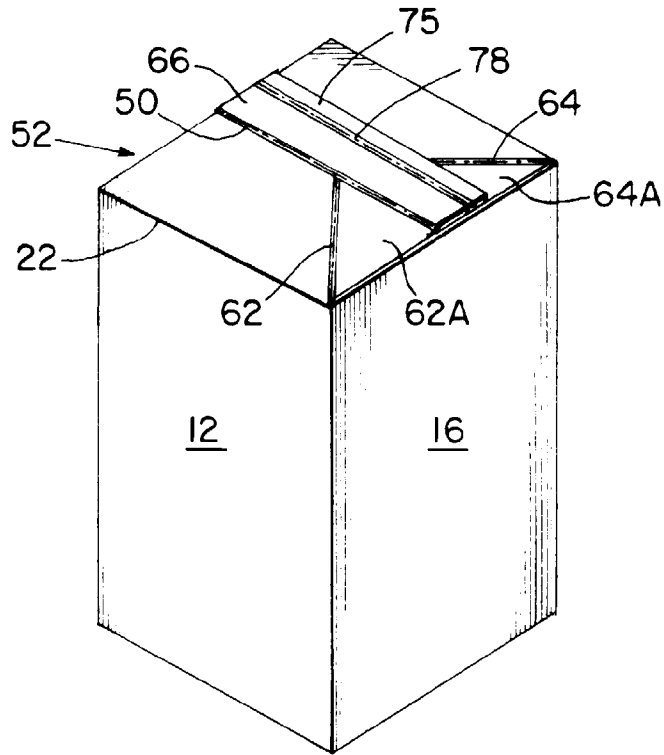
55



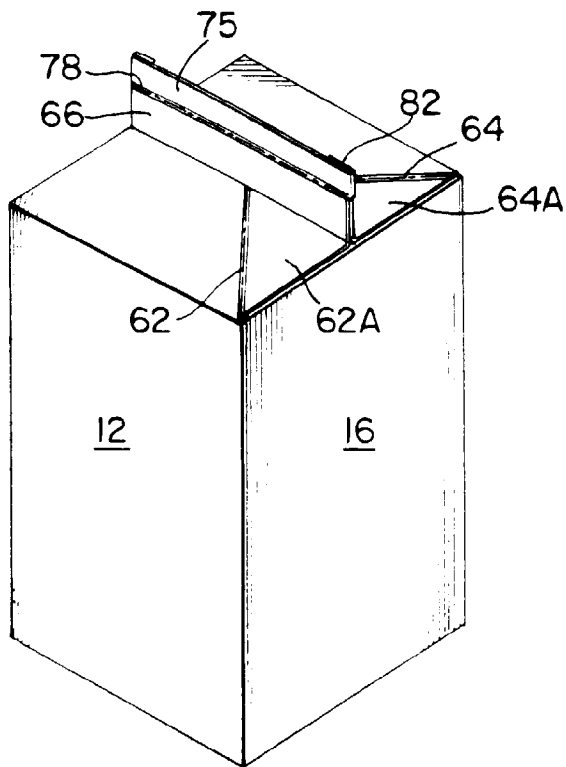
Fig. 2

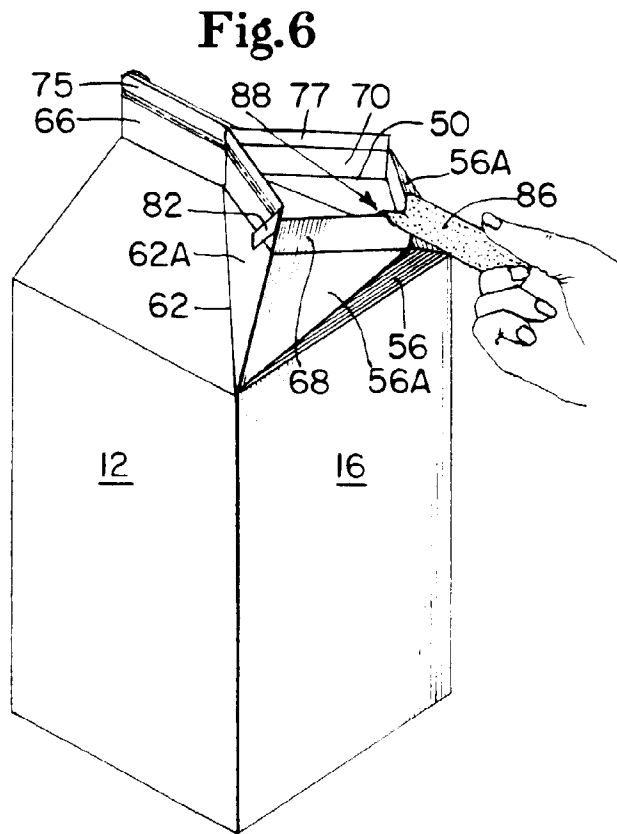
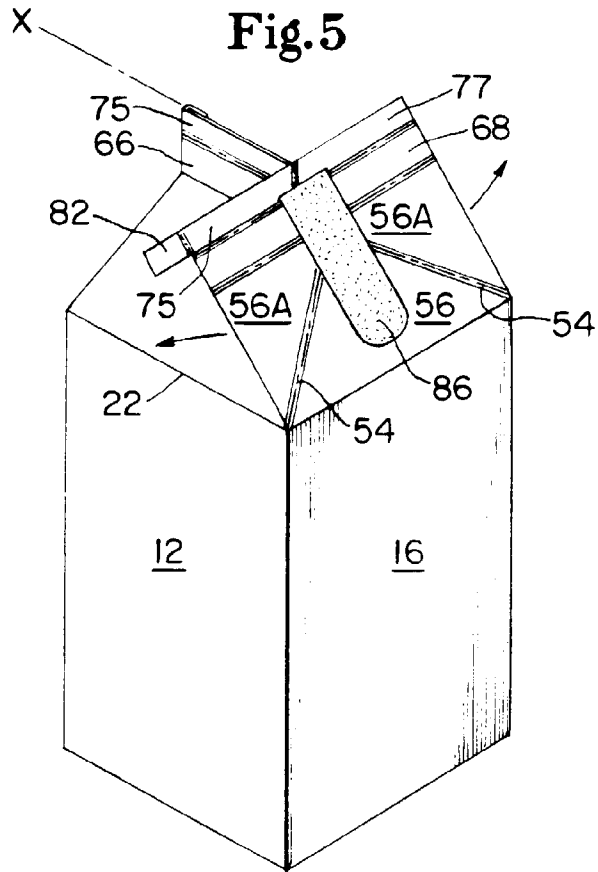


**Fig. 3**



**Fig. 4**





**Fig.7**

