



Europäisches Patentamt
European Patent Office
Office européen des brevets



(11) **EP 0 695 827 B1**

(12) **EUROPEAN PATENT SPECIFICATION**

(45) Date of publication and mention
of the grant of the patent:
15.09.2004 Bulletin 2004/38

(51) Int Cl.7: **D21F 1/00, D21F 7/10**

(21) Application number: **95303854.4**

(22) Date of filing: **06.06.1995**

(54) **Method of seam closure for sheet transfer and other paper processing belts**

Verfahren zum Schliessen des Saums von Überführungs- und anderen Papierbehandlungsbändern

Procédé de jonction de bandes de transfert et autres bandes pour le traitement du papier

(84) Designated Contracting States:
AT BE DE ES FR GB IT NL SE

(30) Priority: **09.06.1994 US 257565**
25.04.1995 US 428661

(43) Date of publication of application:
07.02.1996 Bulletin 1996/06

(73) Proprietor: **ALBANY INTERNATIONAL CORP.**
Albany, New York 12204 (US)

(72) Inventors:
• **Miller, Lawrence G.**
Raynham, Massachusetts 02767 (US)

• **Lotti-Fassnacht, Robin**
Lake Hopatcong, New Jersey 07849 (US)
• **Cooke, Henry M.**
Randolph, Massachusetts 02368 (US)

(74) Representative: **Bradford, Victoria Sophie**
Abel & Imray
20 Red Lion Street
London WC1R 4PQ (GB)

(56) References cited:
WO-A-93/17161 **AT-A- 388 574**

EP 0 695 827 B1

Note: Within nine months from the publication of the mention of the grant of the European patent, any person may give notice to the European Patent Office of opposition to the European patent granted. Notice of opposition shall be filed in a written reasoned statement. It shall not be deemed to have been filed until the opposition fee has been paid. (Art. 99(1) European Patent Convention).

Description

5 [0001] The present invention relates to a method of closing a seam in a polymeric-resin-coated paper processing belt and to a belt so produced. The paper processing belt may be used to carry out the transfer of a paper sheet between sections, or between elements of a section, such as the individual presses in a press section, of the paper machine on which the sheet is being manufactured, or to carry the sheet into other processes. Specifically, the present invention enables a transfer belt to be joined into endless form with a seam during its installation on a paper machine and provides various methods for closing the seam region after the coated seamed transfer belt has been so joined.

10 [0002] At present, the only commercially available paper processing belt of the type described above is a transfer belt. A transfer belt is designed both to carry a paper sheet through a portion of a paper machine, so as to eliminate open draws from the machine and to release the sheet readily to another fabric or belt at some desired point. By definition, an open draw is one in which a paper sheet passes without support from one component of a paper machine to another over a distance which is greater than the length of the cellulose fibers in the sheet, making it susceptible to breakage. The elimination of open draws removes a major cause of unscheduled machine shut-down, namely, the breakage of the sheet at such a point where it is temporarily unsupported by a felt or other sheet carrier. When disturbances in the flow of paper stock occur, the likelihood of such breakage is quite strong where the unsupported sheet is being transferred from one point to another within the press section, or from the final press in the press section to the dryer section. At such points, the sheet usually is at least 50% water, and, as a consequence is weak and readily broken. Clearly, the presence of an open draw will place a limitation on the maximum speed at which the paper machine may be run.

20 [0003] A successful sheet transfer belt must carry out three critical functions on the paper machine: a) to remove the paper sheet from a press fabric without causing sheet instability problems; b) to cooperate with a press fabric in one or more press nips to ensure optimal dewatering and high quality of the paper sheet; and c) to transfer the paper sheet in a closed draw from one press in the press section to a sheet-receiving fabric or belt in the next press, or presses, in the press section, or to a dryer pick-up fabric in the dryer section.

25 [0004] A sheet transfer belt which successfully carries out these critical functions is shown in U.S. Patent No. 5,298,124, entitled "Transfer Belt" and issued on March 29, 1994, the teachings of which are incorporated herein by reference. The transfer belt shown therein has a surface topography characterized by a pressure-responsive, recoverable degree of roughness, so that, when under compression in a press nip, the degree of roughness will decrease, thereby enabling a thin continuous water film to be formed between the transfer belt and a paper sheet to bond the paper sheet to the transfer belt upon exit from the press nip. When the original degree of roughness is recovered after exit from the nip, the paper sheet may be released by the transfer belt, perhaps with the assistance of a minimum amount of vacuum, to a permeable fabric, such as a dryer pick-up fabric.

30 [0005] The sheet transfer belt shown in that patent comprises a reinforcing base with a paper side and a back side, and has a polymer coating, which includes a balanced distribution having segments of at least one polymer, on the paper side. The balanced distribution takes the form of a polymeric matrix which may include both hydrophobic and hydrophilic polymer segments. The polymer coating may also include a particulate filler. The reinforcing base is designed to inhibit longitudinal and transverse deformation of the transfer belt, and may be a woven fabric, and further may be endless or seamable for closing into endless form during installation on the paper machine. In addition, the reinforcing base may contain textile material, and may have one or more fiber batt layers attached by needling onto its back side. By textile material is meant fibers and filaments of natural or synthetic origin, intended for the manufacturing of textiles. The back side may also be impregnated and/or coated with polymeric material.

35 [0006] To date, such sheet transfer belts have been produced for paper mills in endless form, that is, having reinforcing bases either woven in endless form or joined into endless form prior to being coated with the polymer material. The installation of an endless transfer belt on a paper machine, however, is a time-consuming and technically complicated endeavor. It goes without saying that paper production must temporarily cease while the transfer belt installation, or replacement, proceeds. Because the installation of an endless belt cannot be accomplished by snaking or threading the belt through and around the components of the paper machine, it must be inserted from the side of the machine. This necessarily is much more time- and labor-intensive than the installation of an open-ended belt, as machine components, such as press rolls, must be supported while the transfer belt is slipped into the spaces between them from the side. Needless to say, the provision of a sheet transfer belt which may be seamed on the machine would significantly reduce the time and labor required to install, or replace, one on a paper machine.

40 [0007] International Publication No. WO 93/17161, disclosing International Application No. PCT/SE93/00173, shows a joinable band comprising a textile web which is provided from at least one side and through at least part of its thickness with a quantity of thermoplastic material. When heat-softened, the thermoplastic material will fill out the fabric structure of the web at least partially. The edges of respective ends of the band have joining eyelets, which are formed in the textile web and which coact with joining eyelets similarly formed in a meeting end of the band so as to form a detachable join. In order to enable the band to be fitted easily to a machine and to provide the region of the band join with the

same properties as the remainder of the band, no plastic filler is applied to the textile web joining means along a region whose width extension calculated from end edge and inwardly of the web corresponds at least to the extension of the eyelets over that part which coacts with the eyelets of the meeting web end.

5 [0008] The difficulty associated with the provision of an open-ended, or seamable, transfer belt is the marking likely to be left on the paper sheet by the seam region. Because the sheet transfer belt carries a paper sheet through a press nip, and is in direct contact with the paper sheet therein, the slightest difference in caliper, compressibility and surface hardness of the seam region of the belt will leave a mark on the sheet.

10 [0009] Accordingly, the principal object of the present invention is to provide a seamable sheet transfer belt, and methods for closing the seam region, whereby the seam region will have properties substantially identical to those of the remainder of the sheet transfer belt, so that the seam region will not mark the paper sheet.

[0010] It is also an object of the present invention to provide a seamable sheet transfer belt, so that the time and labor required to install or replace such a belt on a paper machine may be reduced.

15 [0011] It is a further object of the present invention to provide a seamable sheet transfer belt, so that existing paper machines may be more readily modified, or adapted to incorporate, the sheet transfer belt shown in U.S. Patent No. 5,298,124, whereby open draws may be eliminated therefrom.

[0012] The present invention provides a method for closing a seam in a polymeric-resin-coated paper processing belt comprising the steps of:

20 providing an open-ended belt comprising a pin-seamable papermaker's fabric having seaming loops at two widthwise edges and having a coating of a first polymeric resin material thereon, said fabric having been coated when temporarily joined in endless form and the resin material subsequently cut at said seam to enable the belt to be re-opened;

installing said open-ended belt on a paper machine;

25 joining said belt into endless form with a pintle by directing said pintle through a passage defined when said seaming loops at said two widthwise edges of said pin-seamable papermaker's fabric are interdigitated with one another, whereby said first polymeric resin material has a slit adjacent to said seaming loops; and

covering said seam on the uncoated side of said belt with a seam area encapsulating material so that said seam may have compression properties substantially identical to those of the remainder of said belt.

30 [0013] Preferably, the open-ended belt is initially prepared by means of the following steps:

providing a pin-seamable papermaker's fabric, said fabric having a paper side, a non-paper side and seaming loops at two widthwise edges for forming a seam;

35 joining said pin-seamable papermaker's fabric into endless form with a first pintle by directing said first pintle through a passage defined when said seaming loops at said two widthwise edges are interdigitated with one another;

coating a side of said papermaker's fabric with a first polymeric resin material;

curing said first polymeric resin material to produce said polymeric-resin-coated paper processing belt;

removing said first pintle;

40 cutting said cured first polymeric resin material at said seam to place said belt in open-ended form.

[0014] The present invention further provides a polymeric-resin-coated paper processing belt comprising:

45 a pin-seamable papermaker's fabric, said fabric having seaming loops formed by machine-direction yarns at two widthwise edges thereof and being joined into an endless form having a paper side and a non-paper side with a pintle directed through a passage defined by the interdigitation of said seaming loops, said pintle and seaming loops thereby constituting a seam for said belt;

a coating of a first polymeric resin material on said paper side of said pin-seamable papermaker's fabric, said coating having a slit at said seam; and

50 seam area encapsulating material covering said seam on said non-paper side of said pin-seamable papermaker's fabric.

[0015] The present invention also provides a papermaking or boardmaking machine provided with a belt as described above.

55 [0016] Accordingly, the present invention comprises several methods for closing the seam area of a coated seamed belt after it has been rejoined into endless form on a paper machine. The objective of the invention is to totally seal the seam while providing it with the same compressive properties as the remainder of the belt under normal nip loads. The sealing technique also distributes the bending stress which would otherwise be concentrated at the coating join

line. This improves the flex fatigue resistance of the join.

[0017] Briefly, in two methods, the prepared seam area of the belt is filled from the non-paper side using a foam of a polymeric material. If necessary, the paper side of the belt may be filled using the same or a different polymeric material, not necessarily a foam. In one method, the foam compound is blown and cured under contact pressure using a heating source with platens and a suitable release medium. During the heating operation, the foam compound expands and fills all voids, including the coating join line. After curing, the heater is removed and the coated surface is finish ground, as necessary, to remove flash. The foam chemistry and the geometry of the heater platens determines the overall compressibility of the seam area in the nip.

[0018] In another method, the polymeric material is pre-foamed prior to its application to the seam area, and is cured by heat as above.

[0019] In still other methods, the seam area may be covered with a solid foam strip of polymeric resin material, or with a fibrous strip of fibrous batt material. Either of these may be attached to the seam area with an adhesive.

[0020] In yet another method, the base fabric of the coated seamed belt may include multiple strand yarns in its machine direction. During the preparation of the seam, the multiple strand yarns may be cut and arranged away from the paper side of the coated seamed belt to form a fibrous filler underneath the seam to replace batt missing from the seam region. Following the seaming operation on the paper machine, the multiple strand yarns may be held in position using a spray adhesive, for example.

[0021] The coated belt may have a construction whereby the seam loops may be positioned in the center of the structure below the coating and above a back layer, which may include a woven fabric, a needled web of fibrous batt material, a polymeric foam, a coating of a polymeric resin material or other nonwoven structures, a material less compressible than a needled web of fibrous batt material, or any combination thereof.

[0022] Alternatively, the back layer may be completely eliminated. The coated surface (paper side) would be closed using a polymeric material, preferably one not foamed, curable at room (ambient) temperature or, more quickly, with the application of heat.

[0023] More specifically, the method of the present invention for closing a seam in a polymeric-resin-coated paper processing belt comprises joining a pin-seamable papermaker's fabric into endless form with a pintle, and coating the outer surface (paper side) of the fabric with a polymeric resin material. Following the curing of the polymeric resin material, and optional surface finishing, the pintle is removed, and the polymeric resin material cut over the seam to leave the now-coated fabric in open-ended form. The belt is then shipped to a paper mill where it is rejoined into endless form with a pintle during installation on a paper machine. The seam is then covered on the uncoated side of the belt, that is, on the inner surface (non-paper side) with a seam area encapsulating material. The encapsulating material may be a viscous paste comprising a polymeric material and a blowing agent. The seam is then gradually heated to a temperature at which the blowing agent decomposes to release a gas, producing a foam from the viscous paste. The foam fills the voids in the seam, and may pass through the break or discontinuity formed when the coating material was cut. The seam is then heated further to the curing temperature of the foam. The curing may glue the break or slit closed, or it may be glued closed with a separate material.

[0024] Alternatively, the encapsulating material may be a pre-foamed polymeric material, wherein the polymeric material is foamed prior to its application to the seam area. The prefoaming may be accomplished through the use of a blowing agent which decomposes at or near room temperature. A low-density filler, comprising expanded thermoplastic microspheres, may be used instead of a blowing agent. Once the pre-foamed polymeric material is applied to the seam area, it is cured as above with the same results.

[0025] Instead of a liquid encapsulating material, a solid foam strip of a polymeric material or a fibrous strip of fibrous batt material may be used as the encapsulating material. In either case, the strip may be secured to the seam region by an adhesive, and the slit may be glued closed with a separate material.

[0026] Alternatively, the base fabric of the coated seamed belt may include multiple strand yarns in its machine direction. The multiple strand yarns may be cut and arranged on the underside of the seam to form a fibrous filler there to replace missing batt material. This fibrous filler may be held in position using, for example, a spray adhesive.

[0027] The present invention also includes belts made in accordance with the above methods. While emphasis is given in the discussion to follow, to the seaming of a sheet transfer belt, the invention may also be applied to the seaming of a long nip press (LNP) belt or of any other polymer-coated belt for the paper industry.

[0028] The present invention enables those skilled in the paper machine clothing arts to control seam compressibility to eliminate, or, at least, to minimize, sheet marking in the nip. A further advantage of the present invention is that distribution of the foam or other material on the underside of the belt in the seam area reduces the stress forces at the coating join. Finally, sealing the coating join may prevent water penetration and possible premature failure of the belt due to coating delamination. It can also reduce sheet marking caused by the join line of the coating.

[0029] The polymeric resin materials referred to above as first, second and third polymeric resin materials, for ease of identification, may comprise the same or different polymeric materials.

[0030] The present invention will now be described in more complete detail with reference frequently being made to

the figures identified as set forth below.

[0031] Figure 1 shows a representative press arrangement including a transfer belt for eliminating an open draw in a paper machine.

[0032] Figure 2 shows a cross-sectional view of a polymeric-resin-coated paper processing belt at a point during its manufacture.

[0033] Figure 3 shows a cross-sectional view of the polymeric-resin-coated paper processing belt at a subsequent point during its manufacture.

[0034] Figure 4 illustrates a method by which the seam may be closed following the installation of the polymeric-resin-coated paper processing belt on a paper machine and is a cross-sectional view of the belt at that time.

[0035] Figure 5 shows a plan view of a seam region of a transfer belt being closed according to an alternative embodiment of the present invention.

[0036] Figure 6 is a side cross-sectional view taken as indicated by line 6-6' in Figure 5.

[0037] Figure 7 illustrates a further method for closing the seam.

[0038] Figure 8 illustrates yet another method by which the seam may be closed.

[0039] Figure 9 shows still another method for closing the seam.

[0040] Figure 10 shows a variation of the method shown in Figure 9.

[0041] A representative press arrangement which includes a transfer belt for eliminating an open draw in a paper machine is shown, for purposes of illustration and general background, in Figure 1. The arrows in Figure 1 indicate the directions of motion or rotation of the elements shown therein.

[0042] In Figure 1, a paper sheet 10, represented by a dashed line, is being carried toward the right initially on the underside of a pick-up fabric 12, which pick-up fabric 12 has previously taken the paper sheet 10 from a forming fabric, not shown.

[0043] The paper sheet 10 and pick-up fabric 12 proceed toward a first vacuum transfer roll 14, around which is trained and directed a press fabric 16. There, suction from within first vacuum transfer roll 14 removes paper sheet 10 from pick-up fabric 12 and draws it onto press fabric 16. Pick-up fabric 12 then proceeds from this transfer point, toward and around a first guide roll 18, and back, by means of additional guide rolls not shown, to the point where it may again receive the paper sheet 10 from a forming fabric.

[0044] Paper sheet 10 then proceeds, carried by press fabric 16, toward a press nip 20 formed between a first press roll 22 and a second press roll 24. Second press roll 24 may be grooved, as suggested by the dashed line within the circle representing it in Figure 1, to provide a receptacle for water removed in the press nip 20 from the paper sheet 10. A transfer belt 26 is trained around first press roll 22, and is directed through press nip 20 with paper sheet 10 and press fabric 16. In the press nip 20, the paper sheet 10 is compressed between the press fabric 16 and the transfer belt 26.

[0045] On exiting press nip 20, paper sheet 10 adheres to the surface of the transfer belt 26, whose surface is smoother than that of the press fabric 16. Proceeding toward the right in the figure from press nip 20, paper sheet 10 and transfer belt 26 approach a second vacuum transfer roll 28. Press fabric 16 is directed by means of second guide roll 30, third guide roll 32 and fourth guide roll 34, back to first vacuum transfer roll 14, where it may again receive paper sheet 10 from pick-up fabric 12.

[0046] At second vacuum transfer roll 28, paper sheet 10 is transferred to a dryer fabric 36, which is trained and directed thereabout. Dryer fabric 36 carries paper sheet 10 toward the first dryer cylinder 38 of the dryer section.

[0047] The transfer belt 26 proceeds onward to the right in the figure away from second vacuum transfer roll 28 to a fifth guide roll 40, around which it is directed to a sixth guide roll 42, a seventh guide roll 44, an eighth guide roll 46, and a ninth guide roll 48, which eventually return it to the first press roll 22 and to the press nip 20, where it may again accept the paper sheet 10 from the press fabric 16.

[0048] As may be observed in Figure 1, the transfer belt 26 also eliminates open draws in the press arrangement shown, most particularly, the open draws often present where the paper sheet 10 is transferred from the press fabric 16 to the dryer fabric 36. Paper sheet 10 is supported at all points in its passage through the press arrangement shown in Figure 1 by a carrier. In addition, it should be noted that the paper sheet 10 is carried on the underside of the transfer belt 26 upon exiting from the press nip 20, because the water film on the transfer belt 26 is strong enough to hold the paper sheet 10.

[0049] To produce the seamed transfer belt according to the present invention, one starts by obtaining a coating base of the OMS (on-machine-seamable) variety, and by temporarily joining it into endless form, the inner surface of the endless loop so formed being the non-paper side of the transfer belt. Figure 2 shows the OMS coating base 52, once seamed and subsequently coated with a polymer coating (as described in more detail below).

[0050] Referring specifically to Figure 2, the seam region 50 of the seamed OMS coating base 52 comprises seaming loops 54, formed by machine-direction yarns 56 at the widthwise edges of the open-ended press fabric 52. When such a coating base 52 is to be closed into endless form, the two ends are brought together, the seaming loops 54 at the ends are interdigitated with one another to form a passage 58, and a pintle 60 is directed through the passage 58 to

interlock seaming loops 54 together. The pintle 60 may be a coarse monofilament as shown in Figure 2. Alternatively, pintle 60 may be a multifilament pintle or a plied monofilament pintle.

[0051] Figure 2 shows one type of coating base 52 that may be used. This coating base 52 includes cross-machine direction yarns 62 and fibrous batt material 64 needled into the base fabric 66 formed by the interwoven machine-direction yarns 56 and cross-machine direction yarns 62. Alternatively, instead of or along with fibrous batt material 64, the back layer of the coating base 52 may include a woven fabric, a polymeric foam, a coating of a polymeric resin material, either the same as or different from that used on the paper side of the coating base 52, or other nonwoven structures, a material less compressible than a needled web of fibrous batt material, or any combination thereof. The use of a material less compressible than a needled web of fibrous batt material is an alternative to making the seam more compressible to achieve similar properties between the seam area and the remainder of the sheet transfer belt.

[0052] Alternatively, the back layer may be completely eliminated. The coated surface (paper side) would in such a case be closed using a polymeric material, preferably one not foamed, which may be curable at room (ambient) temperature or, more quickly, with the application of heat, when the coated seamed belt is installed on the paper machine.

[0053] As noted above, the coating base 52 is temporarily joined into endless form, the outer surface of the endless loop so formed being the paper side of the transfer belt, on a suitable apparatus at the production facility, such that it may be placed under an amount of longitudinal tension analogous to that which it supports when running on a paper machine.

[0054] In such a condition, the outside of the closed loop formed by the coating base 52 is coated with polymer coating 68, which includes a balanced distribution with segments of at least one polymer, forming a polymeric matrix which may include both hydrophobic and hydrophilic polymer segments. The polymer coating 68 may also include a particulate filler 70, as disclosed in U.S. Patent No. 5,298,124.

[0055] The coating 68 is then cured and subsequently ground to provide the transfer belt 72, including seam region 50, with uniform thickness and with a desired surface topography.

[0056] At this point, the transfer belt 72 may be inverted (turned inside-out) if its length and width permit this to be done without causing any damage thereto. Alternatively, the operation to be described next may be carried out from within the closed loop formed by the transfer belt 72, so long as means for disposing the worker to carry out the operation therewithin without damaging the transfer belt 72 are provided.

[0057] In either case, the pintle 60 is removed, and the transfer belt 72 folded at the seam region 50 as shown in Figure 3. That is to say, the transfer belt 72 is folded in such a manner that the coating 68 is on the inside of the fold. The act of folding removes the seaming loops 54 from their interdigitated state, and brings them into a configuration that may be described as two spaced parallel rows of upstanding seaming loops 54. Between the two parallel rows is a portion 74 of the coating 68. That portion 74 is cut by running a sharp implement between the two parallel rows of seaming loops 54 to return the transfer belt 72 to open-ended form, without cutting any of the seaming loops 54.

[0058] In this open-ended form, the transfer belt 72 is packaged, and shipped to a paper mill for installation in the paper machine, such as that illustrated in Figure 1, in the same manner as an OMS press fabric may be installed. It will be recalled that in Figure 1, the transfer belt was identified with reference numeral 26.

[0059] Referring back to Figure 1, the seamable transfer belt 72 is installed on the paper machine instead of endless transfer belt 26 with the polymer coating 68 facing outwardly. A yarn more pliable than coarse monofilament pintle 60 may be used as the final pintle. It now remains to ensure that the seam region 50, and, specifically, that portion 74 of the polymer coating 68 which was cut to make the transfer belt 72 open-ended, does not mark the paper sheet 10 being manufactured on the paper machine.

[0060] With reference to Figure 4, the seam region 50 of seamable transfer belt 72 appears as shown therein when a pintle 76 is used to rejoin it into endless form on a paper machine. A slit 78 remains in the polymer coating 68 more or less directly over the seaming loops 54, and, less seriously, a break 80 remains in the fibrous batt material 64 directly below the seaming loops 54. The loop/pintle combination makes the seam region 50 slightly different from the rest of the seamable transfer belt 72, and raises the possibility that the seam region 50 might mark a paper sheet with which it comes into contact.

[0061] Pintle 76 may be a coarse monofilament pintle, a multifilament pintle, a plied multifilament pintle, a plied monofilament pintle, or a composite pintle including any of these varieties of pintle.

[0062] A foam produced by mixing a fluid polymeric resin material with a blowing agent to form a viscous paste, and by subsequently heating and curing the viscous paste, is used to fill and to cement the seam region 50 and slit 78. A solvent-free urethane composition, such as Adiprene L-100 from Uniroyal, or one based on a polyether-type prepolymer, may be used for this purpose. The following is an example of a solvent-free urethane composition that may be used for this purpose.

Component	Weight (%)
Polyether/TDI polyurethane prepolymer (4.1% NCO)	76.9

(continued)

Component	Weight (%)
Blocked aromatic amine (equivalent weight - 217)	15.4
Endothermic nucleating agent (blowing agent)	7.7

5

10

15

20

25

30

35

40

45

50

55

[0063] Other components such as fillers, plasticizers, and catalysts may be added as needed. The blowing agent, typically a solid particulate material which decomposes to release a gas almost instantaneously when heated to a characteristic temperature, is mixed with the liquid polymeric resin material. The temperature at which the blowing agent activates is typically less than the temperature at which the polymeric resin material cures. For example, the temperature at which the blowing agent decomposes (or blows) may be 115°C, while the temperature at which the polymeric resin material cures may be 130°C, which is the relevant temperature for Adiprene L-100. The blowing agent causes the viscous paste to foam and to expand, filling voids in the seam region 50, and may even pass through the slit 78. In such a manner, the slit 78 may be glued together, and the seam region 50 may be left with the same compressibility and caliper as the rest of the transfer belt 72.

[0064] The viscous paste producing foam 82 is preferably applied first to the non-paper side, or inside, of the seam region 50 of the transfer belt 72 at a point on the paper machine affording ready access to paper mill personnel. For example, the area adjacent to seventh guide roll 44 included in Figure 1 may afford such ready access. The viscosity of the viscous paste producing foam 82 is preferably adjusted, so that it may be easy to apply regardless of the orientation (horizontal, vertical, upside-down, etc.) of the surface to be coated.

[0065] Preferably, the viscous paste may be applied to the seam region 50 of the non paper side of the transfer belt 72 for a distance, such as 0.25 inch (0.64 cm), on both sides of the seam, so that the bending stress may be distributed across the seam region 50, rather than concentrated in one place, such as slit 78.

[0066] Once the seam region 50 on the non-paper side of the seamable transfer belt 72 has been covered with the viscous paste, it may be covered with a material 84 to which the cured foam 82 (obtained from the viscous paste) does not stick, such as heat-resistant release paper, teflon-coated fiberglass tape, and other materials.

[0067] The paper-side surface of the seam region 50 of the seamable transfer belt 72 may also be coated with the viscous paste which produces foam 82, or may optionally be coated with another polymeric coating material, such as that used to provide coating 68, to fill in any cracks in the slit 78. Similarly, once the seam region 50 on the paper side of the seamable transfer belt 72 has been coated in either manner, it may be covered with a material 84 to which the cured foam 82 (obtained from the viscous paste) or other polymeric coating material does not stick.

[0068] A heat source may be used to foam the viscous paste and to cure the foam 82. For example, heat strips 86 may be fashioned from blocks of aluminum having a nominally 0.5 inch thickness, and a width sufficient to completely span the seam region 50 in the belt-running direction. The heat strips 86 include a heating element by which they may be brought gradually from ambient temperature up to and above the temperature at which the foam cures.

[0069] The two heat strips 86 are pressed against the two sides of the seam region 50, so that the caliper of the seam region 50 may be the same as that of the rest of the transfer belt 72. In such position, the heat strips 86 are allowed to rise in temperature from ambient to the blowing temperature, at which the blowing agent included in the viscous paste decomposes and blows the paste, forcing it into voids in the seam region 50. The heating of the heat strips 86 continues above this blowing temperature to the curing temperature of the polymeric resin material, which may cure almost instantaneously at that temperature. Preferably, the curing temperature is maintained for a time sufficient to ensure that the curing process is completed.

[0070] Instead of using two heat strips 86 as described above, a heated sled 100 may be pulled across the seam region 50. Referring to Figure 5, heated sled 100 is drawn across the width of the transfer belt 72 following the seam region 50 at a rate such that the blowing agent included in the viscous paste decomposes and blows the paste, forcing it into voids in the seam region 50; and the curing temperature of the polymeric resin is reached and maintained for a time sufficient to ensure that the curing process is completed. Preferably, the underside of the seam region 50 is supported during this process, so that the heated sled 100 may compress the seam region 50, and ensure that the caliper of the seam region 50 may be the same as the rest of the transfer belt 72.

[0071] Figure 6 is a side cross-sectional view taken as indicated by line 6-6' in Figure 5. Heated sled 100 is drawn across the transfer belt 72 following the seam region 50 by cable 102. Support 104 may be placed beneath the seam region 50 so that heated sled 100 may compress the seam region 50 thereagainst, although tension on the transfer belt 72 could provide adequate support for the sled 100.

[0072] A viscous paste with a very long pot life at room temperature may be used, so that one could work step-by-step across a seam in the case where the seam is not exactly transverse across the belt. A long pot life implies that the paste material may be kept for a long time without its properties changing. If the paste material has a long pot life, the heat strips 86 need not be as wide as the transfer belt 72, and, as stated above, one could work step-by-step across

the seam, such as by using heated sled 100, to seal it in the manner of the present invention.

[0073] After curing, any material 84 applied to the non-paper side and/or paper side of the seam region 50 is removed, and the transfer belt 72 may be moved so that the seam region 50 is on a roll, such as seventh guide roll 44 in Figure 1. There, the surface of polymeric coating 68 may be smoothed by light sanding to remove any seam filling material protruding from the seam area.

[0074] The slit 78 may alternatively be glued with a separate material. The following is an example of a formulation that may be used as the separate material:

Component	Weight (%)
Polyether/TDI polyurethane prepolymer (4.1% NCO)	76.9
Blocked aromatic amine (equivalent weight - 217)	15.4
Kaolin clay	7.7

[0075] As an alternative to the use of a viscous paste obtained by mixing a fluid polymeric resin material with a blowing agent described above, and the subsequent production of a foam 82 therefrom following the application of the viscous paste to the seam region 50, a pre-foamed fluid polymeric resin material could be used instead of the viscous paste. By "pre-foamed" is meant that the foaming is done prior to the application of the material to the seam region 50. This could be accomplished through the use of an endothermic nucleating agent (blowing agent) which decomposes at or near room temperature. These are readily available and well-known to those of ordinary skill in the art.

[0076] Instead of such a blowing agent, a low-density filler could be substituted therefor in the example of the solvent-free urethane composition used to fill the seam region 50 set forth above. A specific low-density filler takes the form of a thermoplastic microsphere containing a hydrocarbon liquid. These microspheres are expanded by heating and remain in an expanded state when cooled. Even following expansion, they remain quite small - on the order of a micron in diameter - and of extremely low density. The use of this variety of low-density filler permits the practitioner to control the density of the foam to be applied to the seam region accurately. That is to say, microspheres could be gradually added to the mixture until a desired density level is reached. An example of such a low-density filler is Expancel DE 551, which product consists of pre-expanded thermoplastic hollow microspheres that are added to "pre-foam" the polymeric material used to cover the seam.

[0077] As a further alternative, a solid foam strip 88 may be applied over the seam region 50, as shown in Figure 7. The solid foam strip 88 may be manufactured from the so-called "pre-foamed" fluid polymeric resin material described above, or from the fluid polymeric resin material including the low-density filler (microspheres). The solid foam strip 88 may be either thermoplastic or thermosetting depending on the manner in which the curing agent included in the fluid polymeric resin material interacts with the end groups in the polymer chains. Where the strip 88 is thermoplastic, it may be secured to the seam region 50 by a heat source, such as a heat strip 86. Alternatively, it may be secured thereto by an adhesive, such as that set forth above for securing the slit 78, which may be pre-applied to the strip 88. Where the strip 88 is thermosetting, it would be secured to the seam region 50 by an adhesive, such as that set forth above for securing the slit 78. Finally, whether thermoplastic or thermosetting, strip 88 may be provided with a heat-activated adhesive for attachment to seam region 50. An example of a heat-activated adhesive that could be used for this purpose is a thermoplastic polyurethane (e.g. Estane resin) applied as a solvent cement and dried.

[0078] As yet another alternative, shown in Figure 8, a fibrous strip 90 of fibrous batt material may be secured over the seam region 50 instead of a solid foam strip 88. The adhesive may be that set forth above for securing the slit 78.

[0079] In each of these alternative approaches the slit 78 may be glued with a separate material, such as that given above by example. The glue formation may be applied to slit 78 prior to the application of any fluid polymeric resin material 82, pre-foamed solid strip 88, or fibrous strip 90 to the seam region 50 on the non-paper side of the belt.

[0080] A further alternative is illustrated in Figures 9 and 10. In both of these figures multiple strand yarns are oriented in the machine direction of the base fabric 66. The multiple strand yarns may be multifilament, spun staple or textured filament yarns.

[0081] It will be noted that there is a gap 106 in the fibrous batt material 64 at the seam region 50. In the preparation of the seam region 50, the multiple strand yarns 108 are cut and arranged away from the polymer coating 68 to form a fibrous filler underneath the seaming loops 54 to replace the fibrous batt material 64 missing from gap 106. The multiple strand yarns 108 may come from one or both sides of the seam region 50 as shown in Figures 9 and 10. Preferably, the multiple strand yarns 108 are incorporated into the base fabric 66 during the weaving process, but they may also be inserted after weaving with a needle, as, for example, in a tufting process.

[0082] After assembly on the paper machine, the multiple strand yarns 108 can be held in place using, for example, a spray adhesive, such as a commercially available acrylic aerosol adhesive. Slit 78 in the polymer coating 78 may be closed using a polymeric material and preferably one which has not been foamed. A polymeric material curable at room (ambient) temperature may be used for this purpose, as well as one whose curing may be accelerated by heating.

[0083] In all of the previously described embodiments of the present invention, non-foaming polymeric materials cured not by heat or ambient temperature, but by ultraviolet light and by other means known to those having ordinary skill in the art may be used.

[0084] It should be understood that the object of each of these alternatives is basically to encapsulate a looped seam, and to provide the encapsulated seam with the compression properties of the remainder of the belt. The method chosen in any given situation will be that which plant personnel will be able to carry out in the shortest time, thereby minimizing the time the papermachine will be down, and not in use for manufacturing paper.

Claims

1. A method for closing a seam in a polymeric-resin-coated paper-processing belt comprising the steps of:

providing an open-ended belt comprising a pin-seamable, papermaker's fabric having seaming loops (54) at two widthwise edges and having a coating of a first polymeric resin material (68) thereon, said fabric having been coated when temporarily joined in endless form and the resin material (68) subsequently cut at said seam (50) to enable the belt to be re-opened;
installing said open-ended belt on a paper machine;
joining said belt into endless form with a pintle (76) by directing said pintle (76) through a passage defined when said seaming loops (54) at said two widthwise edges of said pin-seamable papermaker's fabric are interdigitated with one another, whereby said first polymeric resin material (68) has a slit (78) adjacent to said seaming loops (54); and
covering said seam (50) on the uncoated side of said belt with a seam area encapsulating material, so that said seam (50) has compression properties substantially identical to those of the remainder of said belt.

2. The method as claimed in claim 1 wherein said open-ended belt is prepared by the following steps:

providing a pin-seamable papermaker's fabric, said fabric having a paper side, a non-paper side and seaming loops (54) at two widthwise edges for forming a seam;
joining said pin-seamable papermaker's fabric into endless form with a first pintle (60) by directing said first pintle (60) through a passage (58) defined when said seaming loops (54) at said two widthwise edges are interdigitated with one another;
coating a side of said papermaker's fabric with a first polymeric resin material (68);
curing said first polymeric resin material (68) to produce said polymeric-resin-coated paper-processing belt;
removing said first pintle (60); and
cutting said cured first polymeric resin material (68) at said seam (50) to place said belt in open-ended form.

3. The method as claimed in claim 1 or claim 2 wherein the step of covering said seam (50) comprises:

providing a viscous paste including a second polymeric resin material and a blowing agent;
applying said viscous paste to said seam (50);
causing said blowing agent in said viscous paste to generate gas whereby said viscous paste may become a foam (82); and
curing said foam (82).

4. The method as claimed in claim 3 further comprising the step of applying said viscous paste to said seam (50) on said side of said belt having said coating of first polymeric resin material (68), and optionally, subsequently covering said viscous paste.

5. The method as claimed in claim 3 or claim 4 wherein said steps of causing said blowing agent to generate gas and of curing said foam (82) are carried out while compressing said seam (50), so that said seam may have the same caliper and/or compression properties as the remainder of said polymeric-resin-coated paper-processing belt.

6. The method as claimed in any of claims 3 to 5 wherein said step of causing said blowing agent to generate gas to produce a foam (82) from said viscous paste forces said foam into said slit (78) in said first polymeric resin material (68), and said step of curing said foam (82) causes said slit (78) to be glued together.

7. The method as claimed in claim 1 or claim 2 wherein the step of covering said seam (50) comprises:

5 providing a pre-foamed fluid polymeric resin material including a second polymeric resin material;
applying said pre-foamed fluid polymeric resin material to said seam (50); and
curing said pre-foamed fluid polymeric resin material.

8. The method as claimed in claim 7 wherein, prior to its application to said seam (50), said fluid polymeric resin material is pre-foamed by decomposition of a blowing agent mixed with said second polymeric resin material, or, is pre-foamed by mixing said second polymeric resin material with a low-density filler, said low-density filler preferably comprising expanded thermoplastic microspheres.

9. The method as claimed in claim 1 or claim 2 wherein the step of covering said seam (50) comprises:

15 providing a solid foam strip of a second polymeric resin material; and
attaching said solid foam strip to said uncoated side of said belt over said seam (50), preferably by means of a heat source or an adhesive.

10. The method as claimed in claim 1 or claim 2 wherein the step of covering said seam (50) comprises:

20 providing a fibrous strip of fibrous batt material; and
attaching said fibrous strip to said uncoated side of said belt over said seam (50), preferably by means of an adhesive.

11. The method as claimed in any one of claims 1 to 10 wherein said pin-seamable papermaker's fabric includes multiple strand yarns in its machine direction and wherein the step of covering said seam (50) comprises:

25 cutting said multiple strand yarns on at least one widthwise edge of said pin-seamable papermaker's fabric; and
arranging ends of said multiple strand yarns on said seam (50) on said uncoated side of said belt, and, optionally,
30 holding said ends of said multiple strand yarns in place on said seam (50) by a spray adhesive,
said multiple strand yarns preferably comprising multifilament, spun staple or textured filament yarns.

12. The method as claimed in any one of claims 1 to 11 further comprising the step of covering said encapsulating material subsequent to said step of applying it to said seam (50).

13. The method as claimed in any one of claims 1 to 12 further comprising the step of applying said encapsulating material for a distance on both sides of said seam (50) to cover said seam (50) and a region on both sides thereof, so that bending stresses in said polymeric-resin-coated paper-processing belt may be distributed over a region broader than said seam (50) to relieve said slit from said bending stresses, and so that the region of said seam (50) may have a resistance to bending equivalent to that of the remainder of the belt.

14. The method as claimed in any one of claims 1 to 13 further comprising the steps of gluing said slit (78) with a third polymeric resin material and of curing said third polymeric resin material.

15. The method as claimed in any one of claims 1 to 14 further comprising the step of sanding said seam (50) on said side of said polymeric-resin-coated paper-processing belt having said first polymeric resin material (68) to smooth said seam (50).

16. The method as claimed in any one of claims 1 to 15 wherein said pin-seamable papermaker's fabric includes machine-direction yarns, and wherein said seaming loops (54) are formed by said machine-direction yarns.

17. The method as claimed in any one of claims 1 to 16 wherein said first pintle (60) and/or said second pintle (76) is a coarse monofilament or a multifilament or a plied monofilament pintle, or, said second pintle (76) comprises a composite pintle including a coarse monofilament or a multifilament or a plied monofilament pintle.

18. The method as claimed in any one of claims 1 to 17 wherein said coating step is performed on the paper side of said pin-seamable papermaker's fabric, and wherein the method further comprises any one or more of the following steps:

- i) needling said non-paper side of said pin-seamable papermaker's fabric with fibrous batt material;
- ii) coating said non-paper side of said pin-seamable papermaker's fabric with said first polymeric resin material;
- iii) coating said non-paper side of said pin-seamable papermaker's fabric with a third polymeric resin material;
- iv) attaching a material less compressible than a needled web of fibrous material to said non-paper side of said pin-seamable papermaker's fabric.

19. The method as claimed in any one of claims 1 to 18 further comprising the step of grinding said first polymeric resin material (68) subsequent to said curing step to make said polymeric-resin-coated paper-processing belt uniformly thick and to impart desired surface characteristics thereto.

20. A polymeric-resin-coated paper-processing belt comprising:

a pin-seamable papermaker's fabric, said fabric having seaming loops (54) formed by machine-direction yarns at two widthwise edges thereof and being joined into an endless form having a paper side and a non-paper side with a pintle (76) directed through a passage defined by the interdigitation of said seaming loops (54), said pintle (76) and seaming loops (54) thereby constituting a seam (50) for said belt;

a coating of a first polymeric resin material (68) on said paper side of said pin-seamable papermaker's fabric, said coating having a slit (78) at said seam (50); and

seam area encapsulating material covering said seam (50) on said non-paper side of said pin-seamable papermaker's fabric so that said seam (50) has compression properties substantially identical to those of the remainder of said papermaker's fabric.

21. A belt as claimed in claim 20 wherein said encapsulating material is a foam of a second polymeric resin material impregnating said seam from said non-paper side of said pin-seamable papermaker's fabric, which foam optionally further extends into said slit (78) and seals said slit (78) into a closed condition.

22. A belt as claimed in claim 20 wherein said encapsulating material is a solid foam strip (88) of a second polymeric resin material or is a fibrous strip (90) of fibrous batt material, said strip being attached to said uncoated side of said belt over said seam (50).

23. A belt as claimed in any one of claims 20 to 22 wherein said pin-seamable papermaker's fabric includes multiple strand yarns in a machine direction, and wherein said encapsulating material comprises ends of said multiple strand yarns extending from at least one widthwise edge of said fabric and covering said uncoated side of said belt over said seam (50), said multiple strand yarns optionally being held in place on said seam (50) by a spray adhesive, and preferably comprising multifilament, spun staple or textured filament yarns.

24. A belt as claimed in any one of claims 20 to 23, said non-paper side of said pin-seamable papermaker's fabric being provided with any one or more of the following:

- i) a fibrous batt material needled into said non-paper side;
- ii) a coating of a polymeric resin material on said non-paper side;
- iii) a woven fabric attached to said non-paper side;
- iv) a polymeric foam attached to said non-paper side; and
- v) a material less compressible than a needled web of fibrous batt material attached to said non-paper side.

25. A belt as claimed in any one of claims 20 to 24 wherein said pintle (76) is a monofilament, plied monofilament or plied multifilament pintle, or, is a composite pintle including a monofilament, plied monofilament or plied multifilament pintle.

26. A belt as claimed in any one of claims 20 to 25 wherein said slit (78) is sealed into a closed condition with a cured third polymeric resin material.

Patentansprüche

1. Verfahren zum Schließen einer Naht in einem mit einem Polymerharz beschichteten Papierbehandlungsband, das die folgenden Schritte umfasst:

Vorsehen eines Bandes mit offenen Enden, das einen mittels Nadeln vernähbaren Stoff für die Papierherstellung umfasst, das Nahtschlingen (54) an zwei Kanten in Breitenrichtung besitzt und darauf eine Beschichtung aus einem ersten Polymerharz-Werkstoff (68) aufweist, wobei der Stoff beschichtet worden ist, als er vorübergehend in Endlosform verbunden war, und der Harzwerkstoff (68) anschließend an der Naht (50) abgeschnitten wurde, um ein erneutes Öffnen des Bandes zu ermöglichen;
 Installieren des Bandes mit offenen Enden auf einer Papiermaschine;
 Verbinden des Bandes zu einer Endlosform mit einem Kopplungselement (76), indem das Kopplungselement (76) durch einen Durchlass geführt wird, der definiert wird, wenn die Nahtschlingen (54) an den beiden Kanten in Breitenrichtung des mittels Nadeln vernähbaren Stoffes für die Papierherstellung miteinander verzahnt sind, wobei der erste Polymerharz-Werkstoff (68) in der Nähe der Nahtschlingen (54) einen Schlitz (78) besitzt; und
 Abdecken der Naht (50) auf der unbeschichteten Seite des Bandes mit einem Nahtbereich-Einkapselungswerkstoff, so dass die Naht (50) Kompressionseigenschaften besitzt, die mit jenen des restlichen Bandes im Wesentlichen übereinstimmen.

2. Verfahren nach Anspruch 1, bei dem das Band mit offenen Enden durch die folgenden Schritte vorbereitet wird:

Vorsehen eines mittels Nadeln vernähbaren Stoffes für die Papierherstellung, wobei der Stoff eine Papierseite, eine papierfreie Seite und Nahtschlingen (54) an zwei Kanten in Breitenrichtung, die eine Naht bilden, besitzt;
 Verbinden des mittels Nadeln vernähbaren Stoffes für die Papierherstellung in eine Endlosform mit einem ersten Kopplungselement (60), indem das erste Kopplungselement (60) durch einen Durchlass (58) geführt wird, der definiert wird, wenn die Nahtschlingen (54) an den beiden Kanten in Breitenrichtung miteinander verzahnt sind;
 Beschichten einer Seite des Stoffes für die Papierherstellung mit einem ersten Polymerharz-Werkstoff (68);
 Härten des ersten Polymerharz-Werkstoffs (68), um das mit Polymerharz beschichteten Papierbehandlungsband herzustellen;
 Entfernen des ersten Kopplungselements (60); und
 Schneiden des gehärteten ersten Polymerharz-Werkstoffs (68) an der Naht (50), um das Band in eine Form mit offenem Ende zu bringen.

3. Verfahren nach Anspruch 1 oder Anspruch 2, bei dem der Schritt des Abdeckens der Naht (50) umfasst:

Vorsehen einer viskosen Paste, die einen zweiten Polymerharz-Werkstoff und ein Treibmittel enthält;
 Aufbringen der viskosen Paste auf die Naht (50);
 Bewirken, dass das Treibmittel in der viskosen Paste Gas erzeugt, wodurch die viskose Paste zu einem Schaumstoff (82) werden kann; und
 Härten des Schaumstoffs (82).

4. Verfahren nach Anspruch 3, das ferner den Schritt des Aufbringens der viskosen Paste auf die Naht (50) auf die Seite des Bandes, die die Beschichtung des ersten Polymerharz-Werkstoffs (68) besitzt, und optional des anschließenden Abdeckens der viskosen Paste umfasst.

5. Verfahren nach Anspruch 3 oder Anspruch 4, bei dem die Schritte, bei denen das Treibmittel dazu veranlasst wird, Gas zu erzeugen, und bei denen der Schaumstoff (82) gehärtet wird, während der Kompression der Naht (50) ausgeführt werden, so dass die Naht die gleiche Dicke und/oder die gleichen Kompressionseigenschaften wie das restliche mit Polymerharz beschichtete Papierbehandlungsband haben kann.

6. Verfahren nach einem der Ansprüche 3 bis 5, bei dem der Schritt, bei dem das Treibmittel dazu veranlasst wird, Gas zu erzeugen, um aus der viskosen Paste einen Schaumstoff (82) herzustellen, den Schaumstoff in den Schlitz (78) in dem ersten Polymerharz-Werkstoff (68) zwingt und bei dem der Schritt des Härtens des Schaumstoffs (82) bewirkt, dass der Schlitz (78) zusammengeklebt wird.

7. Verfahren nach Anspruch 1 oder Anspruch 2, bei dem der Schritt des Abdeckens der Naht (50) umfasst:

Vorsehen eines vorgeschäumten fluidartigen Polymerharz-Werkstoffs, der einen zweiten Polymerharz-Werkstoff enthält;
 Aufbringen des vorgeschäumten fluidartigen Polymerharz-Werkstoffs auf die Naht (50); und
 Härten des vorgeschäumten fluidartigen Polymerharz-Werkstoffs.

8. Verfahren nach Anspruch 7, bei dem der fluidartige Polymerharz-Werkstoff vor seiner Aufbringung auf die Naht

(50) durch Zerlegen eines mit dem zweiten Polymerharz-Werkstoffs gemischten Treibmittels vorgeschäumt wird oder durch Mischen des zweiten Polymerharz-Werkstoffs mit einem Füllstoff mit niedriger Dichte vorgeschäumt wird, wobei der Füllstoff mit niedriger Dichte vorzugsweise expandierte thermoplastische Mikrokugeln umfasst.

- 5 9. Verfahren nach Anspruch 1 oder Anspruch 2, bei dem der Schritt des Abdeckens der Naht (50) umfasst:
- Vorsehen eines festen Schaumstoffstreifens eines zweiten Polymerharz-Werkstoffs; und
Befestigen des festen Schaumstoffstreifens an der unbeschichteten Seite des Bandes über der Naht (50),
vorzugsweise mittels einer Wärmequelle oder eines Klebstoffs.
- 10 10. Verfahren nach Anspruch 1 oder Anspruch 2, bei dem der Schritt des Abdeckens der Naht (50) umfasst:
- Vorsehen eines faserartigen Streifens aus einem Faserflor-Werkstoff; und
Befestigen des faserartigen Streifens an der nicht beschichteten Seite des Bandes über der Naht (50), vor-
zugsweise mittels Klebstoff.
- 15 11. Verfahren nach einem der Ansprüche 1 bis 10, bei dem der mittels Nadeln vernähbare Stoff für die Papierherstellung mehrere Litzengarne in seiner Maschinenrichtung enthält und bei dem der Schritt des Abdeckens der Naht (50) umfasst:
- 20 Schneiden der mehreren Litzengarne an wenigstens einer Kante in Breitenrichtung des mittels Nadeln vernähbaren Stoffs für die Papierherstellung; und
Anordnen der Enden der mehreren Litzengarne an der Naht (50) auf der unbeschichteten Seite des Bandes und optional
25 Fixieren der Enden der mehreren Litzengarne auf der Naht (50) durch einen Sprühklebstoff,
- wobei die mehreren Litzengarne vorzugsweise Multifilament-, gesponnene einstufige oder texturierte Filament-Garne umfassen.
- 30 12. Verfahren nach einem der Ansprüche 1 bis 11, das ferner den Schritt des Abdeckens des Einkapselungswerkstoffs nach dem Schritt seiner Aufbringung auf die Naht (50) umfasst.
- 35 13. Verfahren nach einem der Ansprüche 1 bis 12, das ferner den Schritt des Aufbringens des Einkapselungswerkstoffs auf einer Strecke auf beiden Seiten der Naht (50) umfasst, um die Naht (50) und einen Bereich auf beiden Seiten hiervon abzudecken, so dass Biegebeanspruchungen in dem mit Polymerharz beschichteten Papierbehandlungsband auf einem Bereich verteilt werden können, der breiter als die Naht (50) ist, um den Schlitz von den Biegebeanspruchungen zu entlasten, und dass der Bereich der Naht (50) einen Widerstand gegenüber einer Biegung haben kann, der zu jenem des restlichen Bandes äquivalent ist.
- 40 14. Verfahren nach einem der Ansprüche 1 bis 13, das ferner die Schritte des Verklebens des Schlitzes (78) mit einem dritten Polymerharz-Werkstoff und des Härtens des dritten Polymerharz-Werkstoffs umfasst.
- 45 15. Verfahren nach einem der Ansprüche 1 bis 14, das ferner den Schritt des Schmirgelns der Naht (50) auf jener Seite des mit einem Polymerharz beschichteten Papierbehandlungsbandes, die den ersten Polymerharz-Werkstoff (68) besitzt, umfasst, um die Naht (50) zu glätten.
- 50 16. Verfahren nach einem der Ansprüche 1 bis 15, bei dem der mittels Nadeln vernähbare Stoff für die Papierherstellung Maschinenrichtungsgarne enthält und bei dem die Nahtschlingen (54) durch die Maschinenrichtungsgarne gebildet sind.
- 55 17. Verfahren nach einem der Ansprüche 1 bis 16, bei dem das erste Kopplungselement (60) und/oder das zweite Kopplungselement (76) ein grobes Monofilament- oder ein Multifilament- oder ein einstufiges Monofilament-Kopplungselement ist oder bei dem das zweite Kopplungselement (76) ein Verbundkopplungselement umfasst, das ein grobes Monofilament- oder ein Multifilament- oder ein einstufiges Monofilament-Kopplungselement enthält.
18. Verfahren nach einem der Ansprüche 1 bis 17, bei dem der Beschichtungsschritt auf der Papierseite des mittels Nadeln vernähbaren Stoffs für die Papierherstellung ausgeführt wird, wobei das Verfahren ferner einen oder mehrere der folgenden Schritte umfasst:

- i) Vernadeln der papierfreien Seite des mittels Nadeln vernähbaren Stoffs für die Papierherstellung mit einem Faserflor-Werkstoff;
- ii) Beschichten der papierfreien Seite des mittels Nadeln vernähbaren Stoffs für die Papierherstellung mit dem ersten Polymerharz-Werkstoff;
- 5 iii) Beschichten der papierfreien Seite des mittels Nadeln vernähbaren Stoffs für die Papierherstellung mit einem dritten Polymerharz-Werkstoff;
- iv) Befestigen eines Werkstoffs, der weniger komprimierbar ist als eine vernadelte Bahn aus einem faserartigen Material an der papierfreien Seite des mittels Nadeln vernähbaren Stoffs für die Papierherstellung.
- 10 **19.** Verfahren nach einem der Ansprüche 1 bis 18, das ferner den Schritt des Schleifens des ersten Polymerharz-Werkstoffs (68) nach dem Härtungsschritt umfasst, um die Dicke des mit einem Polymerharz beschichteten Papierbehandlungsbandes gleichmäßig zu machen und um ihm eine gewünschte Oberflächeneigenschaft zu verleihen.
- 15 **20.** Papierbehandlungsband, das mit einem Polymerharz beschichtet ist und umfasst:
- einen mittels Nadeln vernähbaren Stoff für die Papierherstellung, der Nahtschlingen (54) besitzt, die durch Maschinenrichtungsgarne an zwei Kanten in Breitenrichtung hiervon ausgebildet sind, und der zu einer Endlosform mit einer Papierseite und einer papierfreien Seite verbunden ist, wobei ein Kopplungselement (76) durch einen Durchlass verläuft, der durch die Verzahnung der Nahtschlingen (54) definiert ist, wobei das Kopplungselement (76) und die Nahtschlingen (54) eine Naht (50) für das Band bilden;
- 20 eine Beschichtung aus einem ersten Polymerharz-Werkstoff (68) auf der Papierseite des mittels Nadeln vernähbaren Stoffs für die Papierherstellung, wobei die Beschichtung bei der Naht (50) einen Schlitz (78) besitzt; und
- 25 einen Nahtbereich-Einkapselungswerkstoff, der die Naht (50) auf der papierfreien Seite des mittels Nadeln vernähbaren Stoffs für die Papierherstellung abdeckt, so dass die Naht (50) Kompressionseigenschaften besitzt, die mit jenen des restlichen Stoffs für die Papierherstellung im Wesentlichen übereinstimmen.
- 30 **21.** Band nach Anspruch 20, bei dem der Einkapselungswerkstoff ein Schaumstoff aus einem zweiten Polymerharz-Werkstoff ist, der die Naht von der papierfreien Seite des mittels Nadeln vernähbaren Stoffs für die Papierherstellung imprägniert, wobei sich der Schaumstoff optional weiter in den Schlitz (78) erstreckt und den Schlitz (78) in einen geschlossenen Zustand abdichtet.
- 35 **22.** Band nach Anspruch 20, bei dem der Einkapselungswerkstoff ein fester Schaumstoffstreifen (88) aus einem zweiten Polymerharz-Werkstoff ist oder ein faserartiger Streifen (90) aus Faserflormaterial ist, wobei der Streifen an der unbeschichteten Seite des Bandes über der Naht (50) befestigt ist.
- 40 **23.** Band nach einem der Ansprüche 20 bis 22, bei dem der mittels Nadeln vernähbare Stoff für die Papierherstellung mehrere Litzengarne in Maschinenrichtung enthält und bei dem der Einkapselungswerkstoff Enden der mehreren Litzengarne aufweist, die sich von wenigstens einer Kante in Breitenrichtung des Stoffs erstrecken und die unbeschichtete Seite des Bandes über der Naht (50) abdecken, wobei die mehreren Litzengarne optional durch einen Sprühklebstoff an der Naht (50) fixiert sind und vorzugsweise Multifilament-, gesponnene einstufige oder texturierte Filament-Garne umfassen.
- 45 **24.** Band nach einem der Ansprüche 20 bis 23, wobei die papierfreie Seite des mittels Nadeln vernähbaren Stoffs für die Papierherstellung mit irgendeinem oder mehreren der folgenden Materialien versehen ist:
- i) ein Faserflor-Werkstoff, der in die papierfreie Seite genadelt ist;
- ii) eine Beschichtung aus einem Polymerharz-Werkstoff auf der papierfreien Seite;
- 50 iii) ein gewebter Stoff, der an der papierfreien Seite befestigt ist;
- iv) ein Polymerschaumstoff, der an der papierfreien Seite befestigt ist; und
- v) ein Werkstoff, der weniger komprimierbar ist als eine genadelte Bahn aus Faserflor-Werkstoff, der an der papierfreien Seite befestigt ist.
- 55 **25.** Band nach einem der Ansprüche 20 bis 24, bei dem das Kopplungselement (76) ein Monofilament-, gestuftes Monofilament- oder gestuftes Multifilament-Kopplungselement ist oder ein Verbundkopplungselement ist, das ein Monofilament-, einstufiges Monofilament- oder einstufiges Multifilament-Kopplungselement enthält.

26. Band nach einem der Ansprüche 20 bis 25, bei dem der Schlitz (78) in einem geschlossenen Zustand mit einem gehärteten dritten Polymerharz-Werkstoff abgedichtet ist.

5 **Revendications**

1. Procédé de fermeture d'une couture dans une courroie de traitement de papier recouverte de résine de polymère, comprenant les étapes suivantes :

10 on fournit une courroie à extrémités ouvertes comprenant une toile de fabrication de papier pouvant être cousue à l'aiguille et comportant des boucles de couture (54) en deux bords en largeur et portant un revêtement en un premier matériau de résine polymère (68), la toile ayant été revêtue alors qu'elle était momentanément reliée en forme sans fin et le matériau de résine (68) ensuite coupé à la couture (50) pour permettre de rouvrir la courroie,

15 on installe la courroie à extrémités ouvertes sur une machine à papier, on relie la courroie en une forme sans fin avec une broche (76) en dirigeant la broche (76) à travers un passage défini lorsque les boucles de couture (54) aux deux bords selon la largeur de l'étoffe de fabrication de papier pouvant être cousus à l'aiguille sont mutuellement entrelacés, si bien que le premier matériau de résine polymère (68) a une fente (78) adjacente aux boucles de couture (54), et

20 on couvre la couture (50), sur le côté non revêtu de la courroie, par un matériau d'encapsulation de zone de couture, de sorte que la couture (50) a des propriétés de compression sensiblement identiques à celles du reste de la courroie.

- 25 2. Procédé selon la revendication 1, dans lequel la courroie à extrémités ouvertes est préparée par les étapes suivantes :

on fournit une étoffe de fabrication de papier pouvant être cousue à l'aiguille, l'étoffe ayant un côté papier, un côté non-papier et des boucles de couture (54) en deux bords en largeur pour former une couture, on relie l'étoffe de fabrication de papier en une forme sans fin par une première broche (60) en dirigeant la première broche (60) à travers un passage (58) défini lorsque les boucles de couture (54) aux deux bords en largeur sont mutuellement entrelacées,

30 on revêt un côté de l'étoffe de fabrication de papier par un premier matériau de résine polymère (68), on fait durcir le premier matériau de résine polymère (68) pour produire la courroie de traitement de papier revêtue de résine polymère,

35 on enlève la première broche (60), et on coupe le premier matériau de résine polymère (68) à la couture (50) pour mettre la courroie en forme à extrémités ouvertes.

- 40 3. Procédé selon l'une des revendications 1 et 2, dans lequel l'étape de couverture de la couture (50) comprend les étapes suivantes :

on fournit une pâte visqueuse comprenant un second matériau de résine polymère et un agent gonflant, on applique la pâte visqueuse sur la couture (50), on provoque le fait que l'agent gonflant dans la pâte visqueuse engendre du gaz, de sorte que la pâte visqueuse peut devenir une mousse (82), et

45 on fait durcir la mousse (82).

4. Procédé selon la revendication 3, comprenant en outre l'étape d'application de la pâte visqueuse à la couture (50) sur le côté de la courroie comportant le revêtement de premier matériau de résine polymère (68), et, le cas échéant, on couvre ensuite la pâte visqueuse.

5. Procédé selon l'une des revendications 3 et 4, dans lequel les étapes faisant que l'agent gonflant engendre du gaz et de durcissement de la mousse (82) sont effectuées alors que l'on comprime la couture (50), de sorte que la couture peut avoir le même calibre et/ou propriétés de compression que le reste de la courroie de traitement de papier revêtue de résine polymère.

- 55 6. Procédé selon l'une des revendications 3 à 5, dans lequel l'étape consistant à faire que l'agent gonflant engendre du gaz pour produire de la mousse (82) à partir de la pâte visqueuse force la mousse dans la fente (78) dans le

premier matériau de résine polymère (68), et l'étape de durcissement de la mousse (82) fait que la fente (78) est collée avec.

- 5
7. Procédé selon l'une des revendications 1 et 2, dans lequel l'étape de couverture de la couture (50) comprend :
- la fourniture d'un matériau de résine polymère fluide à pré-moussage comprenant un second matériau de résine polymère,
l'application du matériau de résine polymère fluide à pré-moussage à la couture (50), et
le durcissement du matériau de résine polymère fluide à pré-moussage.
- 10
8. Procédé selon la revendication 7, dans lequel, avant son application à la couture (50), le matériau de résine polymère fluide est pré-moussé par décomposition d'un agent gonflant mélangé avec le second matériau de résine polymère, ou, est pré-moussé par mélange du second matériau de résine polymère avec une charge de faible densité, la charge de faible densité comprenant de préférence des microsphères de thermoplastique expansé.
- 15
9. Procédé selon l'une des revendications 1 et 2, dans lequel l'étape de couverture de la couture (50) comprend :
- la fourniture d'une bande de mousse solide d'un second matériau de résine polymère, et
on fixe la bande de mousse solide au côté non-revêtu de la courroie sur la couture (50), de préférence au
moyen d'une source thermique ou d'un adhésif.
- 20
10. Procédé selon l'une des revendications 1 et 2, dans lequel l'étape de couverture de la couture (50) comprend :
- la fourniture d'une bande fibreuse de matériau de nappe fibreuse, et
on fixe la bande fibreuse sur le côté non-revêtu de la courroie sur la couture (50), de préférence au moyen
d'un adhésif.
- 25
11. Procédé selon l'une quelconque des revendications 1 à 10, dans lequel l'étoffe de fabrication de papier pouvant être cousue à l'aiguille comprend des fils multibrins dans sa direction machine et dans lequel l'étape de couverture de la couture (50) comprend les étapes suivantes :
- 30
- on coupe les fils multibrins sur au moins un bord en largeur de l'étoffe de fabrication de papier, et
on dispose les extrémités des fils multibrins sur la couture (50) sur le côté non-revêtu de la courroie, et, le cas échéant,
on maintient en place les dites extrémités des fils multibrins sur la couture (50) par un adhésif en spray,
les fils multibrins comprenant de préférence des fils multi-filaments, filé ordinaire ou à filaments texturés.
- 35
12. Procédé selon l'une quelconque des revendications 1 à 11, comprenant en outre l'étape de couverture du matériau d'encapsulation après l'étape d'application de celui-ci sur la couture (50).
- 40
13. Procédé selon l'une quelconque des revendications 1 à 12, comprenant en outre l'étape d'application du matériau d'encapsulation sur une certaine distance des deux côtés de la couture (50) pour couvrir la couture (50) et une région des deux côtés de celle-ci, de sorte que des contraintes de flexion dans la courroie de traitement de papier revêtue de résine polymère peuvent être réparties sur une région plus grande que la couture (50) pour soulager la fente de ces contraintes de flexion, et de sorte que la région de la couture (50) peut avoir une résistance à la flexion équivalente à celle du reste de la courroie.
- 45
14. Procédé selon l'une quelconque des revendications 1 à 13, comprenant en outre les étapes de collage de la fente (78) par un troisième matériau de résine polymère et de durcissement du troisième matériau de résine polymère.
- 50
15. Procédé selon l'une quelconque des revendications 1 à 14, comprenant en outre l'étape de sablage de la couture (50) sur le côté, de la courroie de traitement de papier revêtue de résine polymère, comportant le premier matériau de résine polymère (68), pour lisser la couture (50).
- 55
16. Procédé selon l'une quelconque des revendications 1 à 15, dans lequel l'étoffe de fabrication de papier pouvant être cousue à l'aiguille comprend des fils à direction machine, et dans lequel les boucles de couture (54) sont formées par les fils à direction machine.

17. Procédé selon l'une quelconque des revendications 1 à 16, dans lequel la première broche (60) et/ou la seconde broche (76) est une broche grossière monofilament ou multifilament ou monofilament retors, ou, la seconde broche (76) comprend une broche composite comprenant une broche grossière monofilament ou multifilament ou monofilament retors.
- 5
18. Procédé selon l'une quelconque des revendications 1 à 17, dans lequel l'étape de revêtement est effectuée sur le côté papier de l'étoffe de fabrication de papier pouvant être cousue à l'aiguille, et dans lequel le procédé comprend en outre l'une quelconque ou plus des étapes suivantes :
- 10
- i) on coud le côté non-papier, de l'étoffe de fabrication de papier pouvant être cousue à l'aiguille, avec un matériau en nappe fibreux,
 - ii) on revêt le côté non-papier, de l'étoffe de fabrication de papier pouvant être cousue à l'aiguille, d'un matériau de résine polymère,
 - 15
 - iii) on revêt le côté non-papier, de l'étoffe de fabrication de papier pouvant être cousue à l'aiguille, d'un troisième matériau de résine polymère,
 - iv) on fixe un matériau moins compressible qu'une toile de matériau fibreux au côté non-papier de l'étoffe de fabrication de papier pouvant être cousue à l'aiguille.
- 20
19. Procédé selon l'une quelconque des revendications 1 à 18, comprenant en outre l'étape de meulage du premier matériau de résine polymère (68) après l'étape de durcissement pour faire que la courroie de traitement de papier revêtue de résine polymère soit d'épaisseur uniforme et pour y impartir des caractéristiques de surface voulues.
20. Courroie de traitement de papier revêtue de résine polymère, comprenant :
- 25
- une étoffe de fabrication de papier pouvant être cousue, l'étoffe ayant des boucles de couture (54) formées par des fils à direction machine en deux bords en largeur de celle-ci et étant reliée en une forme sans fin ayant un côté papier et un côté non-papier par une broche (76) dirigée à travers un passage défini par l'entrelacement des boucles de couture (54), la broche (76) et les boucles de couture (54) constituant ainsi une couture (50) pour la courroie,
 - 30
 - un revêtement d'un premier matériau de résine polymère (68) sur le côté papier de l'étoffe de fabrication de papier pouvant être cousue à l'aiguille, le revêtement ayant une fente (78) à la couture (50), et
 - un matériau d'encapsulation de zone de couture couvrant la couture (50) sur le côté non-papier de l'étoffe de fabrication de papier pouvant être cousue à l'aiguille, de sorte que la couture (50) a des propriétés de compression sensiblement identiques à celles du reste de l'étoffe de fabrication de papier.
 - 35
21. Courroie selon la revendication 20, dans laquelle le matériau d'encapsulation est une mousse en un second matériau de résine polymère imprégnant la couture depuis le côté non-papier de l'étoffe de fabrication de papier pouvant être cousue à l'aiguille, cette mousse, le cas échéant, s'étendant en outre dans la fente (78) et scellant la dite fente (78) en un état fermé.
- 40
22. Courroie selon la revendication 20, dans laquelle le matériau d'encapsulation est une bande de mousse solide (88) d'un second matériau de résine polymère ou est une bande fibreuse (90) de matériau de nappe fibreuse, la bande étant fixée au côté non-revêtu de la courroie sur la couture (50).
- 45
23. Courroie selon l'une quelconque des revendications 20 à 22, dans laquelle l'étoffe de fabrication de papier pouvant être cousue à l'aiguille comprend des fils à brins multiples dans une direction machine, et dans laquelle le matériau d'encapsulation comprend des extrémités des fils à brins multiples s'étendant depuis au moins un bord en largeur de l'étoffe et couvrant le côté non-revêtu de la courroie sur la couture (50), les fils à brins multiples étant éventuellement maintenus en place sur la couture (50) par un adhésif en spray, et comprenant de préférence des fils multifilaments, filé ordinaire ou à filaments texturés.
- 50
24. Courroie selon l'une quelconque des revendications 20 à 23, dans laquelle le côté non-papier de l'étoffe de fabrication de papier pouvant être cousue à l'aiguille comporte l'un au moins de ce qui suit :
- 55
- i) un matériau de nappe fibreuse cousu dans le côté non-papier,
 - ii) un revêtement de matériau résine polymère sur le côté non-papier,
 - iii) une toile tissée fixée au côté non-papier,
 - iv) une mousse polymère fixée au côté non-papier, et

EP 0 695 827 B1

v) un matériau moins comprimable qu'une toile cousue de matériau de nappe fibreuse, fixé au côté non-papier.

5 **25.** Courroie selon l'une quelconque des revendications 20 à 24, dans laquelle la broche (76) est une broche monofilament, monofilament retors ou multifilament retors, ou est une broche composite comprenant une broche monofilament, monofilament retors ou multifilament retors.

10 **26.** Courroie selon l'une quelconque des revendications 20 à 25, dans laquelle la fente (78) est scellée en un état fermé par un troisième matériau de résine polymère durcie.

15

20

25

30

35

40

45

50

55

FIG. 1

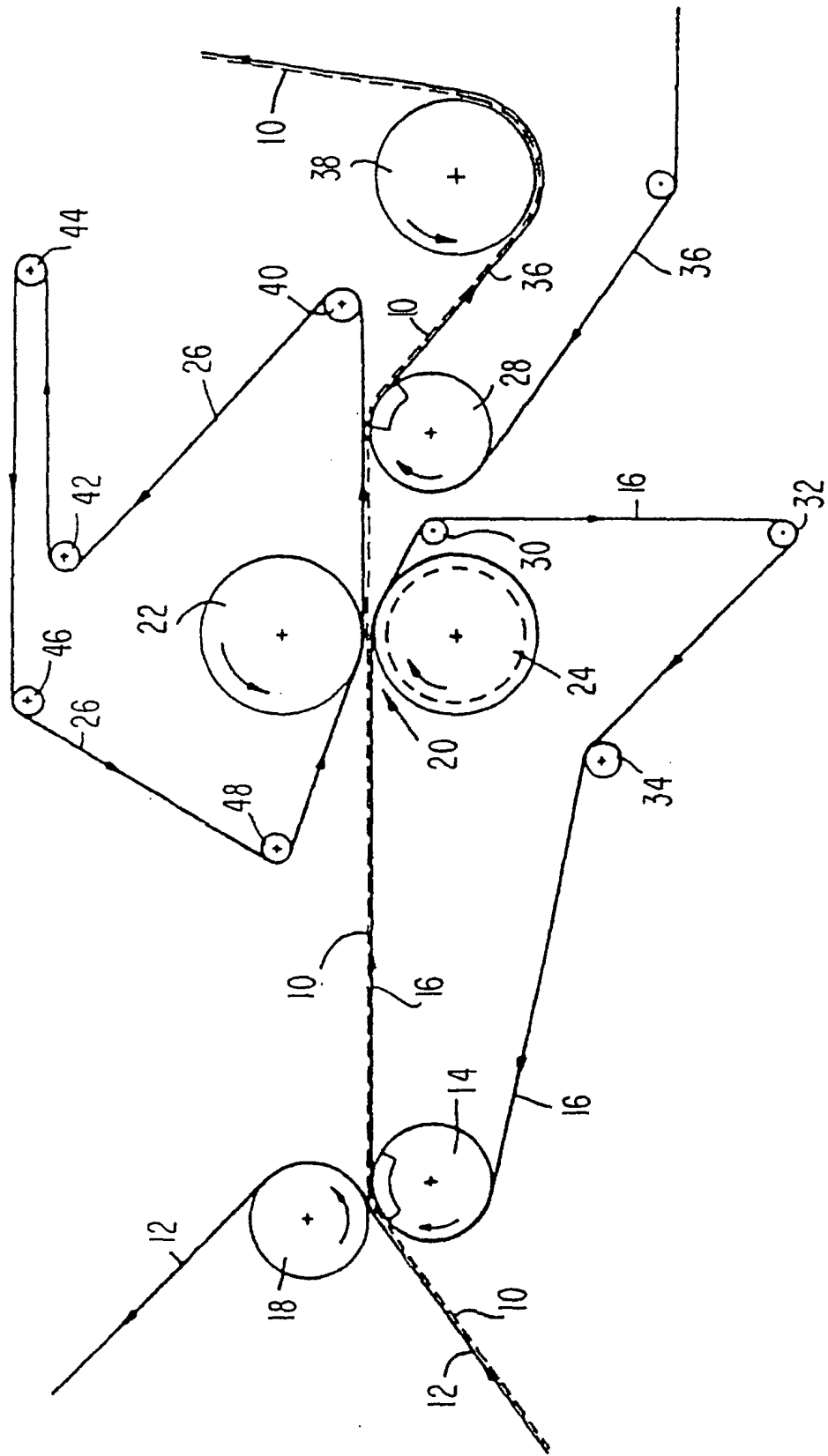
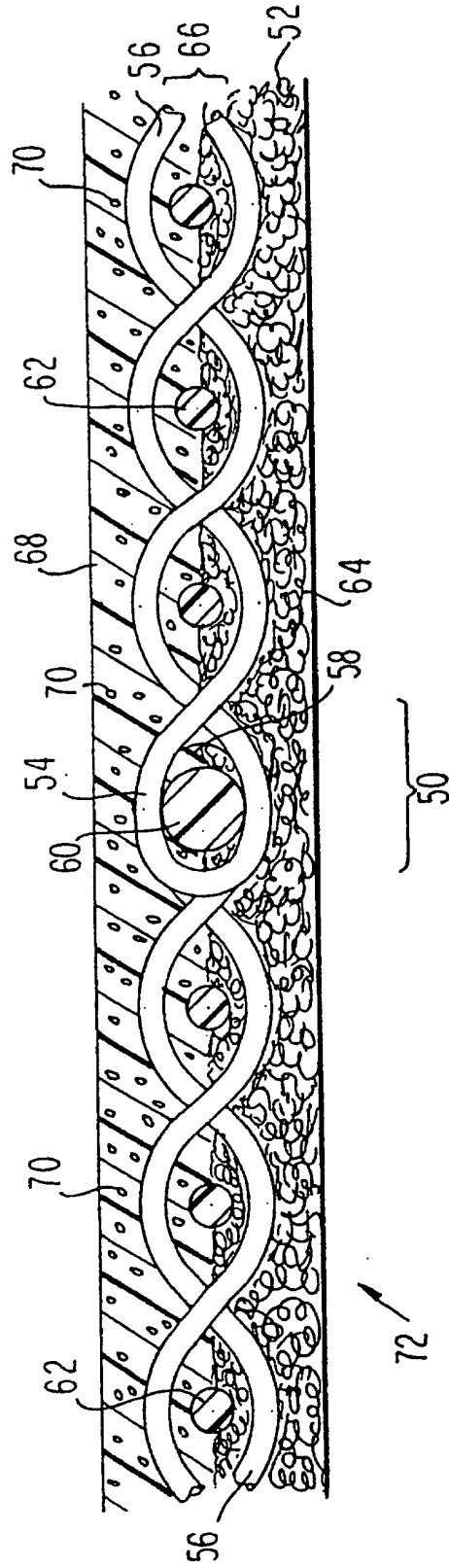

FIG.2



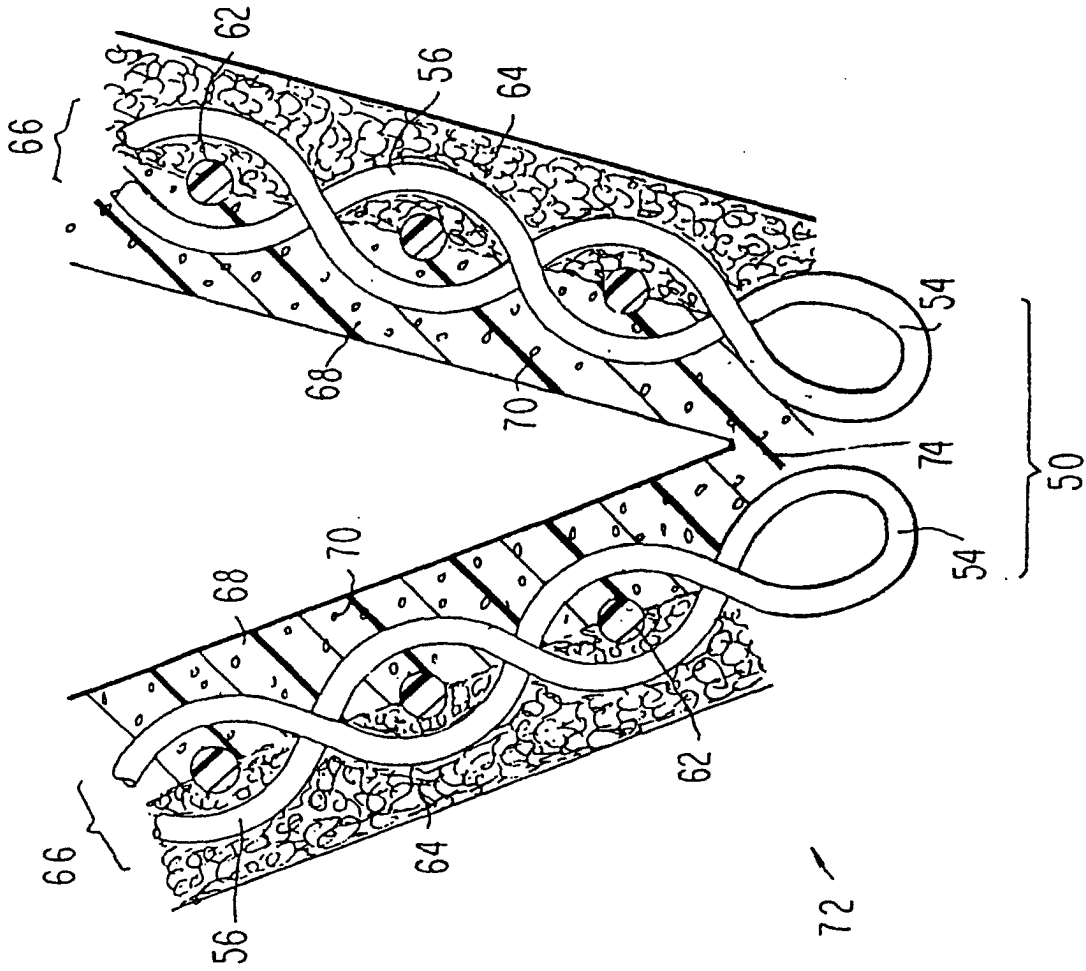

FIG. 3

FIG. 4

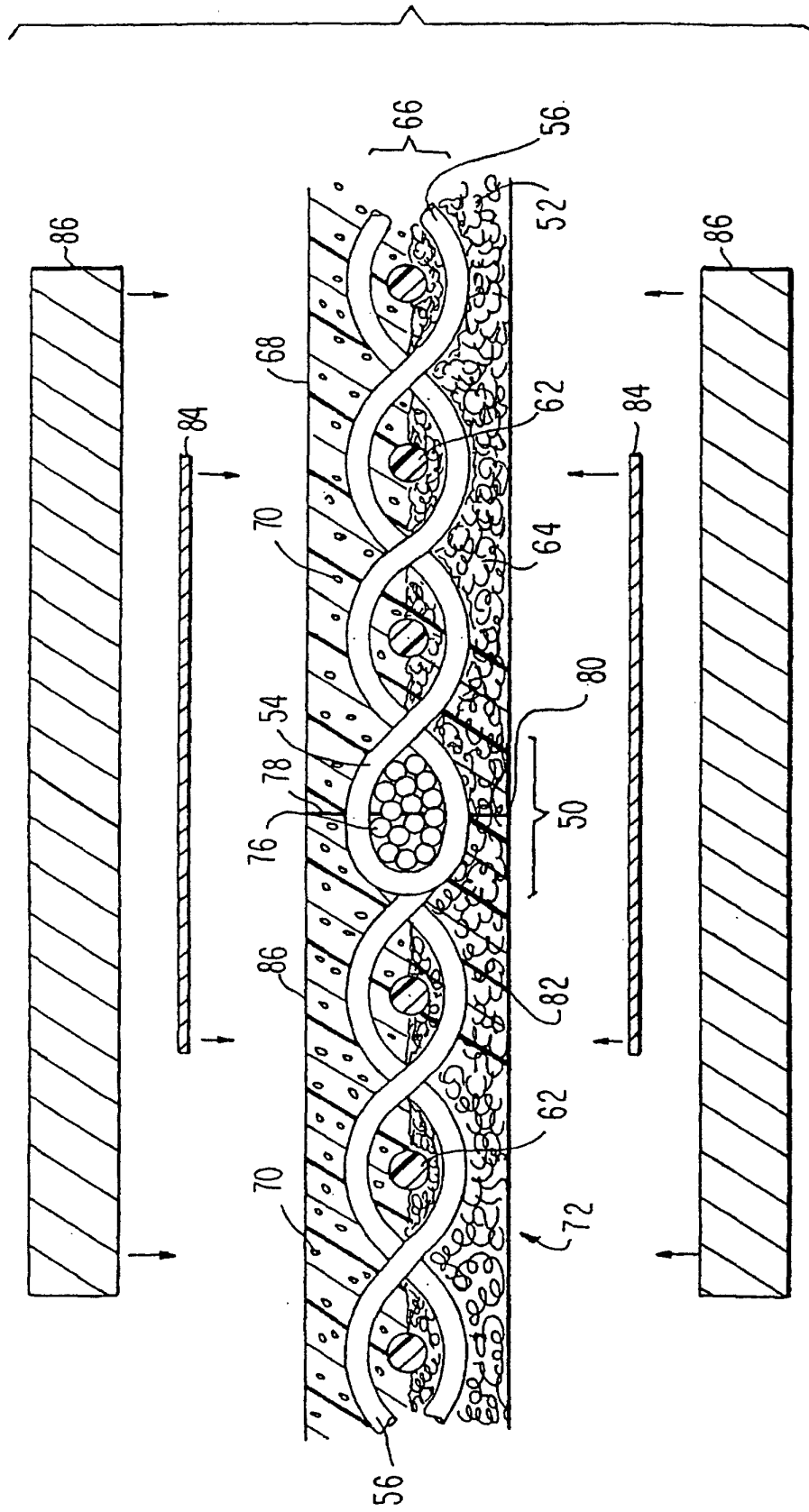

FIG. 5

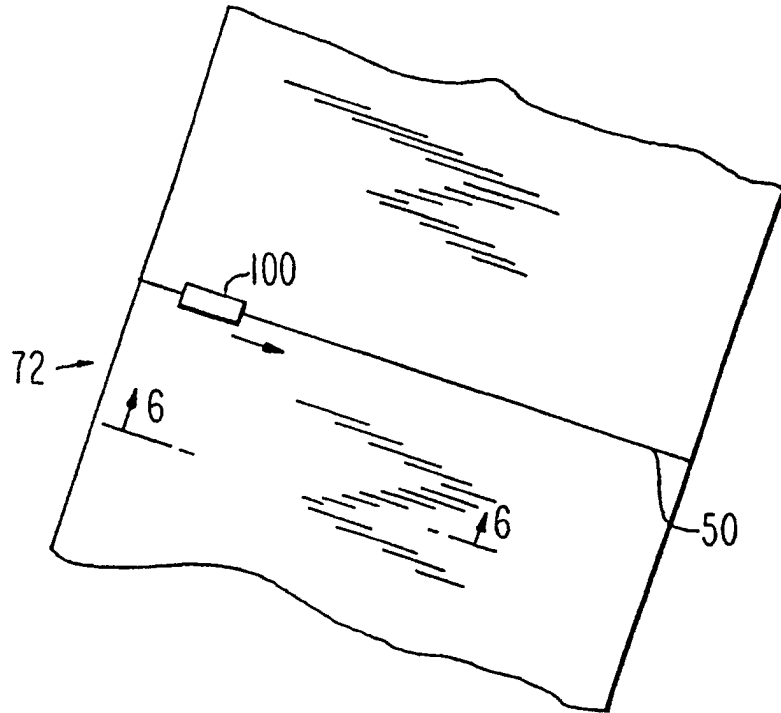

FIG. 6

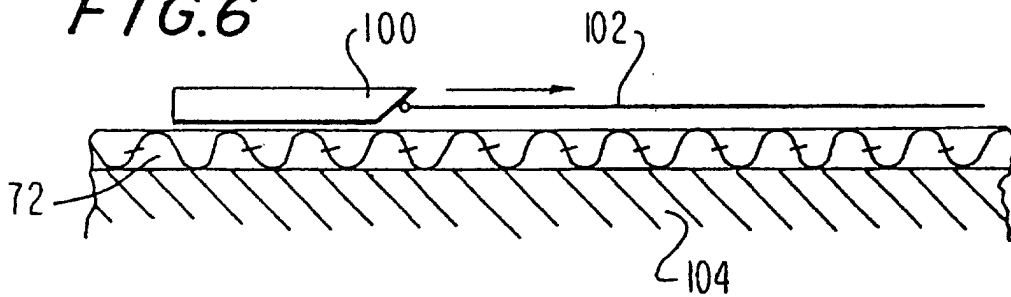

FIG. 7

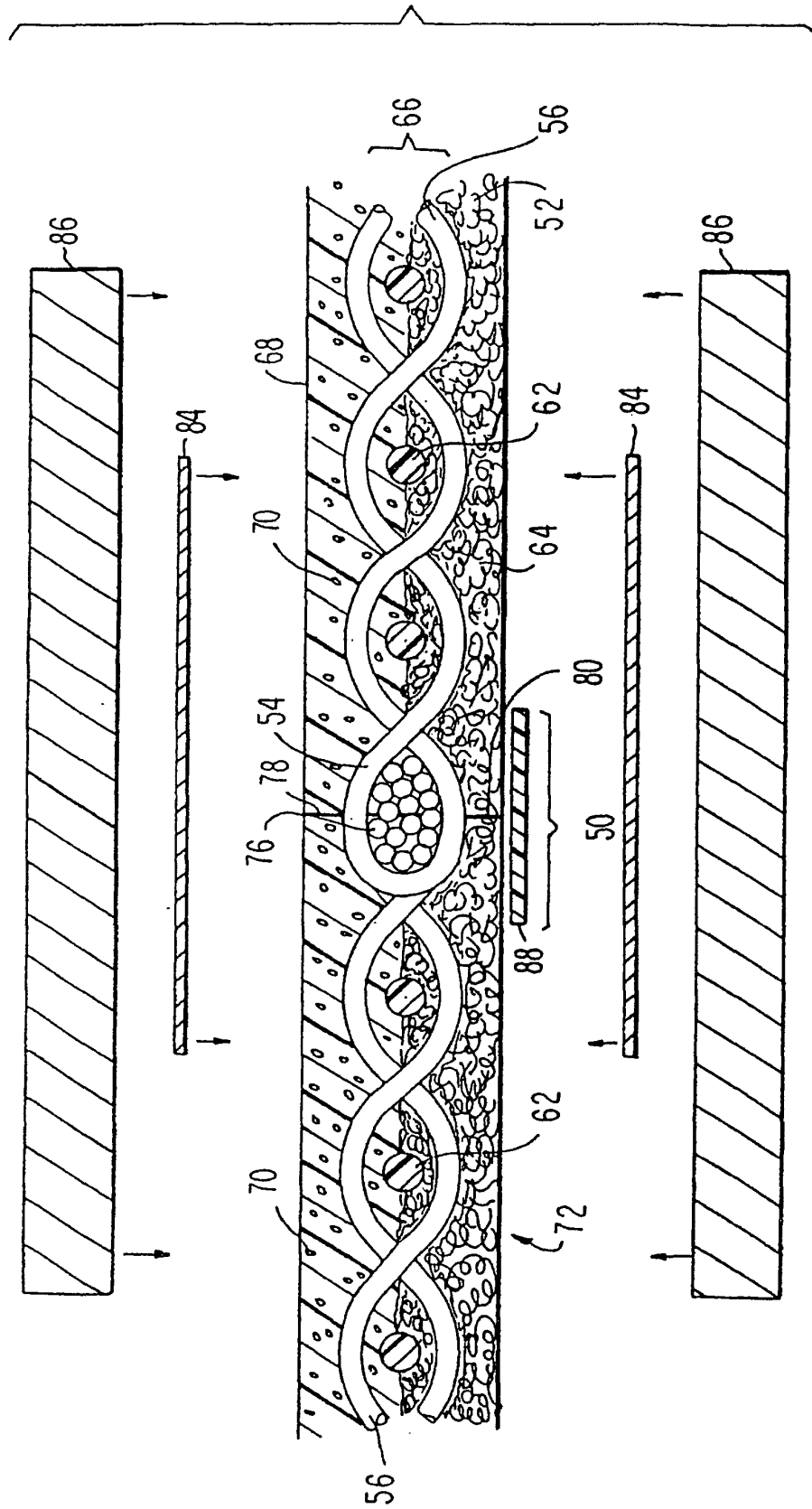

FIG. 8

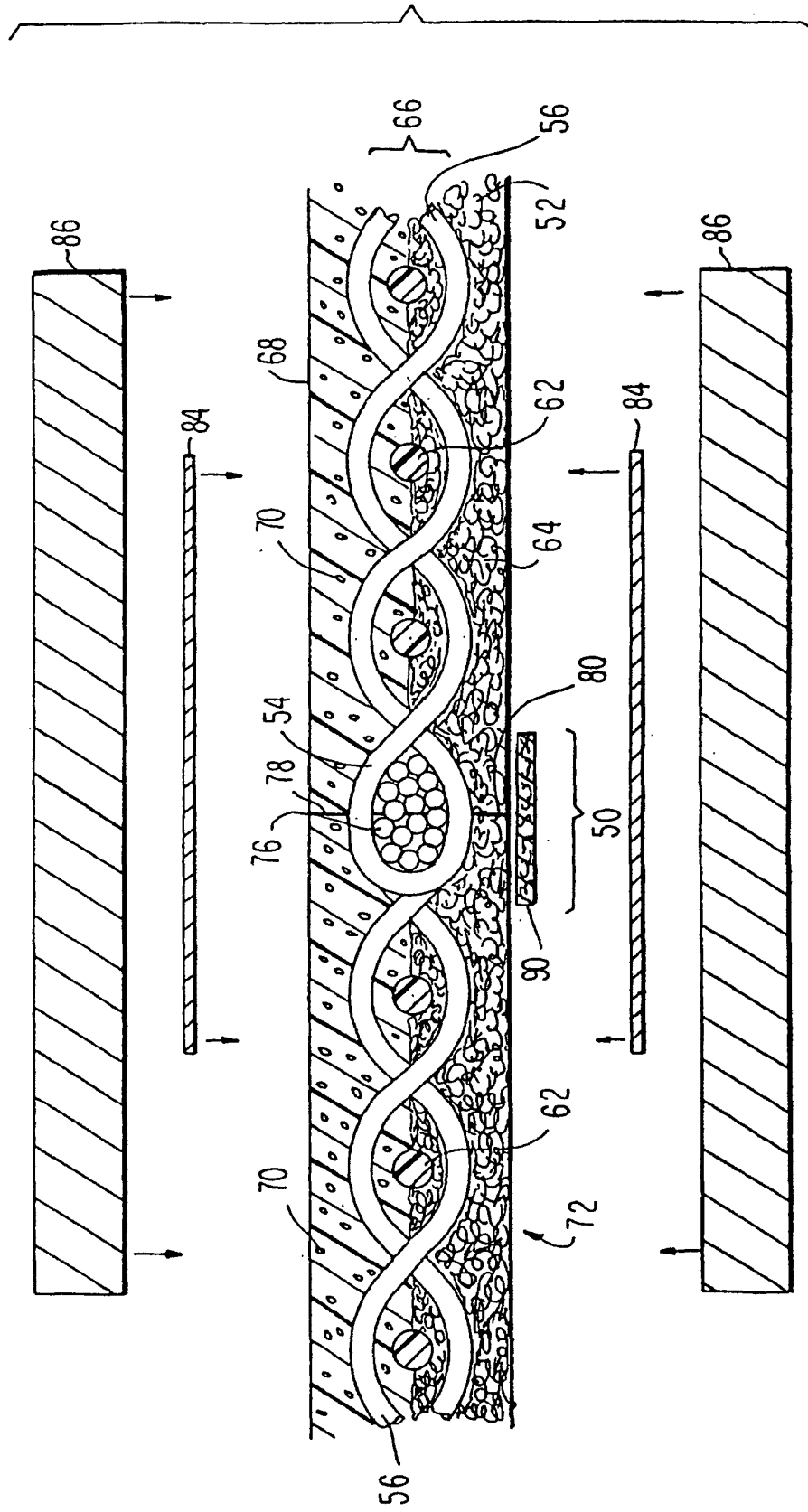

FIG. 9

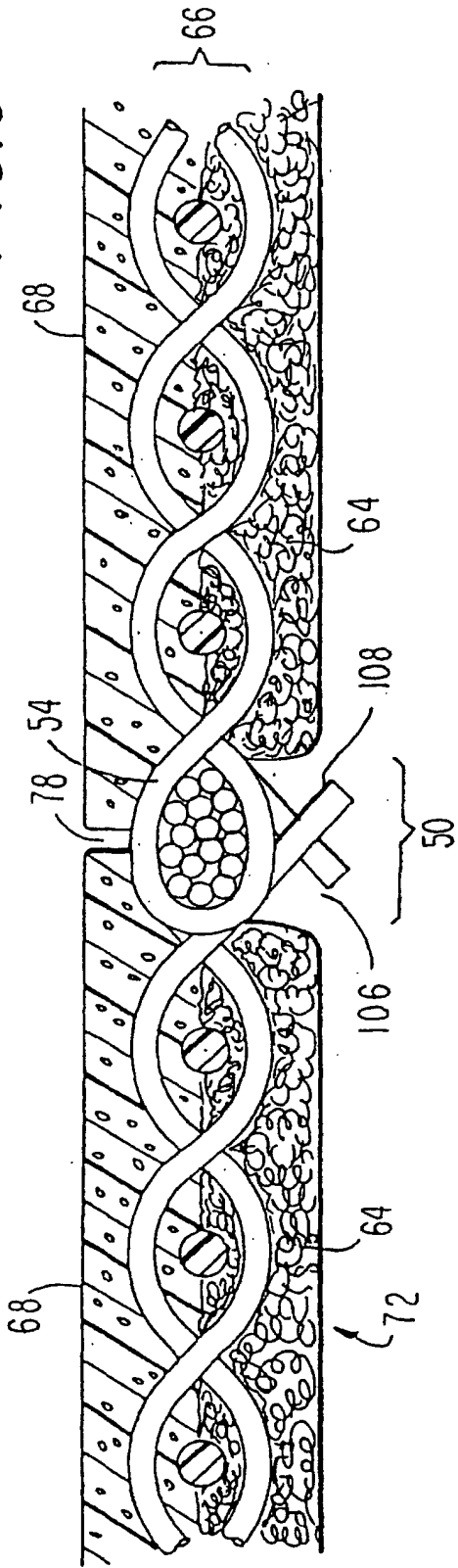

FIG. 10

