



Europäisches Patentamt
European Patent Office
Office européen des brevets



(11) **EP 0 725 463 B1**

(12) **EUROPEAN PATENT SPECIFICATION**

(45) Date of publication and mention
of the grant of the patent:
12.07.2000 Bulletin 2000/28

(51) Int Cl.7: **H01T 13/32**

(21) Application number: **96300722.4**

(22) Date of filing: **01.02.1996**

(54) **A spark plug for an internal combustion engine**

Zündkerze für einen Verbrennungsmotor

Bougie d'allumage pour moteur à combustion interne

(84) Designated Contracting States:
DE FR GB IT

(30) Priority: **01.02.1995 JP 1492095**

(43) Date of publication of application:
07.08.1996 Bulletin 1996/32

(73) Proprietor: **NGK SPARK PLUG CO., LTD**
Nagoya-shi (JP)

(72) Inventors:
• **Matsubara, Yoshihiro**
Nagoya-shi (JP)

• **Kunitomo, Iwao**
Nagoya-shi (JP)

• **Ito, Shoichiro**
Nagoya-shi (JP)

(74) Representative: **Senior, Alan Murray**
J.A. KEMP & CO.,
14 South Square,
Gray's Inn
London WC1R 5LX (GB)

(56) References cited:
EP-A- 0 518 707 **DE-U- 8 811 215**
GB-A- 2 027 797 **US-A- 1 942 242**
US-A- 2 314 128

EP 0 725 463 B1

Note: Within nine months from the publication of the mention of the grant of the European patent, any person may give notice to the European Patent Office of opposition to the European patent granted. Notice of opposition shall be filed in a written reasoned statement. It shall not be deemed to have been filed until the opposition fee has been paid. (Art. 99(1) European Patent Convention).

Description

[0001] This invention relates to a spark plug for use in an automotive internal combustion engine.

[0002] With the recent requirement of an enhanced fuel efficiency, it has been demanded to run an automobile engine with rarefied fuel gas. In realizing the lean burn engine, it is quintessential to improve significantly the ignitability of the spark plug to burn rarefied fuel gas so as to run the engine with the lean burn operation. In order to satisfy the requirement, a spark plug has been conceived in which a center electrode is substantially extended for an ignition position near to a center of a combustion chamber of the internal combustion engine.

[0003] In a prior spark plug, however, an outer electrode has been used whose cross sectional shape is rectangular. Due to the angles of the rectangular section of the outer electrode, a flame extinguishing effect (a cooling effect) appears to impede a flame core to grow, and at the same time, a swirl of an air-mixture gas is disturbed so as to deteriorate the ignitability against the air-mixture gas. This is all the more particularly when the electrode is extended longer into the combustion chamber of the internal combustion engine. While at the same time, the ignitability is influenced depending on which side the outer electrode is oriented when the spark plug is mounted on a cylinder head of the internal combustion engine.

[0004] Therefore, it is one of the objects of the invention to provide a spark plug for an internal combustion engine which is capable of uniformly improving an ignitability regardless of which side an outer electrode is oriented.

DE-U1-8811215.2 discloses a spark plug comprising:

- an insulator having an axial bore;
- a center electrode placed within the axial bore of the insulator, a front end portion of the center electrode extending beyond a front end of the insulator;
- a metallic shell supporting the insulator so that the front end of the insulator extends from a front end of the metallic shell; and
- at least one outer electrode connected to the front end of the metallic shell to form a spark gap with the front end portion of the center electrode;

wherein the firing surface of said at least one outer electrode is formed into a flat-shaped configuration to provide the spark gap with the front end portion of the center electrode.

[0005] As indicated in the accompanying claims, the present invention is characterised in that the outer surface of a portion of said at least one outer electrode ahead of a base portion of said at least one outer electrode is formed to have a smoothly curved profile which is not angular and is without any corner edges.

[0006] In addition, the spark plug may have at least one outer electrode forming a spark gap with an eleva-

tional side of the center electrode.

[0007] In some forms of the present invention, a cross-section of the front firing portion of the outer electrode is formed into a semi-circular or polygonal shape whose corners are rounded to have a radius of 0.5 mm or more, while a cross-section of the other portion of the outer electrode except for the front firing side surface is formed into a circular, semi-circular, elliptical or polygonal shape whose corners are rounded to have a radius of 0.5 mm or more.

[0008] In other forms of the present invention, the outer electrodes other than the one forming the spark gap with the front end surface of the center electrode, form a spark gap with an elevational side of the center electrode, a cross section of the outer electrode being a semi-circular, elliptical or polygonal shape having corners rounded to have a radius of 0.5 mm or more.

[0009] A cross-section of the outer electrode may be formed into a semi-circular, elliptical or polygonal shape whose corners are rounded to have a radius of 0.5 mm or more. At least the outer surface of the outer electrode is formed by the smoothly curved profile against the center electrode, and be located at a portion ahead of a base portion in which the outer electrode is connected to the metallic shell. A cross-section of the portion ahead of a base portion in which the outer electrode is connected to the metallic shell, may be formed into a circular, semi-circular, elliptical or polygonal shape whose corners are rounded to have a radius of 0.5 mm or more.

[0010] The outer electrode which forms the spark gap with the elevational side of the center electrode may have a front firing end formed into a flat-shaped configuration.

[0011] The outer electrode which forms the spark gap with the elevational side of the center electrode may have a front firing end formed into a bight-shaped notch corresponding to the elevational side of the center electrode.

[0012] With the invention, at least the outer surface of the outer electrode is formed by a smoothly curved profile against the center electrode. This means it is possible to reduce the influence of the outer electrode against the streams of the air-fuel mixture. That is to say, the smoothly curved profile makes it possible to substantially decrease the disturbance against the air-fuel mixture streams so as to insure smooth streams of the air-fuel mixture admitted to an ignition portion without impeding an entry of the streams into the ignition portion, and thus enables to an improved ignitability and a decreased variation of the ignitability depending on which side the outer electrode is oriented.

[0013] With the smoothly curved profile located at a portion ahead of a base end in which the outer electrode is connected to the metallic shell, it is also possible to reduce the influence of the outer electrode against the streams of the air-fuel mixture. Namely, the smoothly curved profile makes it possible to substantially decrease the disturbance against the air-fuel mixture

streams so as to insure smooth streams of the air-fuel mixture admitted to an ignition portion without impeding an entry of the streams into the ignition portion, and thus enables to an improved ignitability and a decreased variation of the ignitability depending on which side the outer electrode is oriented.

[0014] With the front firing side surface of the outer electrode formed into a flat-shaped configuration so as to provide the spark gap with the front end portion of the center electrode, it is possible to effectively resist against spark erosion so as to contribute to an extended service life. It is noted "the smoothly curved profile" signifies that the outer surface is not angular without having any edged corner through all these instances.

[0015] These and other objects, aspect and embodiments of the invention will be described in more detail, by way of example only, with reference to the following drawing figures, of which:-

Fig. 1 is a half longitudinal cross sectional view of a firing portion of a spark plug according to a first embodiment of the invention;

Fig. 2 is a latitudinal cross sectional view of an outer electrode taken along the lines A-A of Fig. 1;

Figs. 3a and 3b are latitudinal cross sectional views of an outer electrode taken along the lines B-B of Fig. 1;

Fig. 4a is an elevational view of the firing portion of the spark plug;

Fig. 4b is an elevational view of the firing portion of the spark plug looked from an arrow C of Fig. 4a;

Fig. 5a is an elevational view of the firing portion of a prior art spark plug;

Fig. 5b is an elevational view of the firing portion of a prior art spark plug looked from an arrow D of Fig. 5a;

Fig. 6 is a graph shown to compare an ignitability between the prior art and the present invention;

Fig. 7a, 7b and 7c are latitudinal cross sectional views of various outer electrodes according to a second embodiment of the invention;

Fig. 8 is a half longitudinal cross sectional view of a firing portion of a spark plug according to a third embodiment of the invention;

Fig. 9 is a half longitudinal cross sectional view of a firing portion of a spark plug according to a fourth embodiment of the invention;

Fig. 10a is a plan view of a firing portion of a spark plug not according to the claimed invention;

Fig. 10b is a half longitudinal cross sectional view of a firing portion of the spark plug of Fig. 10a.

Fig. 11a is a plan view of a firing portion of a spark plug according to a fifth embodiment of the invention;

Fig. 11b is a half longitudinal cross sectional view of a firing portion of a spark plug according to the fifth embodiment of the invention;

Fig. 12 is a half longitudinal cross sectional view of

a firing portion of a spark plug according to a sixth embodiment of the invention; and

Fig. 13 is a half longitudinal cross sectional view of a firing portion of a spark plug according to a seventh embodiment of the invention.

[0016] Referring to Figs. 1, 2, 3a, 3b, 4a and 4b which show an upper portion of a spark plug 1 according to a first embodiment of the invention, the spark plug 1 has a center electrode 3 and an outer electrode 5. The center electrode 3 is placed within an axial bore 2a of an insulator 2, and the ground electrode 5 is connected to a front end 4a of a metallic shell 4 which supportedly encloses the insulator 2. The center electrode 3 locates its front end surface 3a to form a spark gap G with the outer electrode 5.

[0017] The center electrode 3 is a composite structure in which a copper or copper based core is embedded in a nickel or nickel based clad, and the front end surface 3a of the center electrode 3 is extended beyond a front end 2b of the insulator 2 by a predetermined length.

[0018] The outer electrode is made of a nickel or nickel based alloy, and having one end turned toward the front end surface 3a of the center electrode 3, while having the other end welded to the front end 4a of a metallic shell 4. Except for a front firing side surface 5a of the outer electrode 5 which forms the spark gap G with the front end surface 3a of the center electrode 3, a cross sectional shape of the outer electrode 5 is circular as shown in Fig. 2. The front firing side surface 5a of the outer electrode 5 is formed into a flat-shaped configuration, and a cross section of the outer electrode 5 including the front firing side surface 5a has a semi-circular shape or rectangular (square) shape whose four corners (R) are rounded to have a radius of 0.5 mm or more as shown in Figs. 3a and 3b. In Figs. 3a and 3b, the semi-circular surface 5g and the rounded corners (R) of the outer electrode 5 serve as a smoothly curved profile to rectify streams of air-fuel mixture flowing along the outer electrode 5 upon taking the air-fuel mixture into a combustion chamber of the internal combustion engine.

[0019] The outer electrode 5 is manufactured as follows:

(i) A linear blank circular in cross section is welded to the front end 4a of the metallic shell 4, and thereafter cut into a predetermined length.

(ii) Its front end portion which is to form the spark gap G with the center electrode 3 is pressed to form into the circular or rectangular (generally square) cross section by means of pressing procedure so as to provide the flat-shaped configuration (front firing side surface 5a) at one side which is to meet the front end surface 3a of the center electrode 3.

(iii) Then, a front portion of the outer electrode 5 is turned toward the center electrode 3 to face the front end surface 3a of the center electrode 3 so as to form the spark gap G whose width is substantially

uniform from one side to another.

[0020] With the outer electrode 5 substantially rectangular or semi-circular in cross section, it is possible to reduce the influence of the outer electrode 5 against the streams of the air-fuel mixture. That is to say, the outer electrode 5 is formed into a smoothly curved profile which makes it possible to substantially decrease a fluid resistance against the air-fuel mixture streams so as to insure smooth streams of the air-fuel mixture admitted to an ignition portion without impeding an entry of the streams into the ignition portion, and thus enables to an improved ignitability and a decreased variation of the ignitability depending on which side the outer electrode 5 is oriented.

[0021] An experimental test was carried out to compare the ignitability (lean burn limit air-to-fuel ratio) between the outer electrode 5 of the present invention (Figs. 4a and 4b) and an outer electrode 50 of a prior art spark plug (Figs. 5a and 5b). In this instance, the outer electrode 5 employed by the spark plug 1 measures 1.7 mm in diameter (d1). A lateral region extended by 3.0 mm from a front end surface 5e of the outer electrode 5 with the front firing side surface 5a included, is formed into a generally semi-circular shape in cross section.

[0022] Meanwhile, the prior art outer electrode 50 is rectangular in cross section, and measures 2.8 mm (w: width) \times 1.6 mm (t: thickness). In both the present outer electrode 5 and the prior art outer electrode 50, the center electrodes 3, 30 measure 2.6 mm in diameter (d2), and extend by 8.5 mm (h1) beyond the front ends 2b, 20b of the insulators 2, 20 respectively. Front ends of the insulators 2, 20 extend by 1.5 mm (h2) beyond the front ends 4a, 40a of the metallic shells 4, 40 respectively.

[0023] Fig. 6 shows an experimental test result by comparing the ignitability (lean burn limit air-to-fuel ratio) between the outer electrode 5 of the present invention and the outer electrode 50 of the prior art spark plug. In the prior art outer electrode 50 made by the rectangular blank, it is found that the ignitability reduces such a degree as to unacceptably vary depending on which side the outer electrode is oriented when mounting the spark plug on the cylinder head of the internal combustion engine. In the outer electrode 5 according to the present invention, it is found that the ignitability is improved, and its variation decreases depending on which side the outer electrode is oriented when mounting the spark plug on the cylinder head of the internal combustion engine.

[0024] Since the front firing side surface 5a of the outer electrode 5 is formed into the flat-shaped configuration to provide the spark gap G with the front end surface 3a of the center electrode 3, it is possible to lessen an amount of the spark erosion so as to extend the service life, as opposed to an instance in which a convex portion meets the front end surface 3a of the center electrode 3.

[0025] Figs. 7a, 7b and 7c show a second embodiment of the invention in which a cross section of the outer electrode 5 is a semi-circular, elliptical or rectangular shape whose four corners (R) are rounded to have a radius of 0.5 mm or more. It is preferable to form the cross section of the outer electrode 5 into a generally squarely shaped configuration when taking the fluid resistance and flame extinguishing effect into consideration. In these instances, it is observed that the cross section of the outer electrode 5 is a semi-circular or rectangular (including generally square) shape whose corners are rounded to have a radius of 0.5 mm or more when cutting at the front firing side surface 5a of the outer electrode 5 in the same manner as described in the first embodiment of the invention.

[0026] Fig. 8 shows a third embodiment of the invention in which the outer electrode 5 is a composite structure having a copper or copper-based core 5c embedded in a nickel or nickel-based clad 5b in order to facilitate a heat-drawing action so as to suppress an oxidation-based erosion of the outer electrode 5.

[0027] Fig. 9 shows a fourth embodiment of the invention in which a front end portion of the center electrode is thinned such as to be 1.0 ~ 1.5 mm in diameter (d), and a spark-erosion resistant noble tip 6 welded to the front end surface 3a of the center electrode 3 so as to form the spark gap G with the outer electrode 5. In this instance, the noble tip 6 is made of Pt, Ir, Pt-Ir based alloy or Pt-Ni based alloy. With the center electrode 3 thus thinned, it is possible to lessen the flame extinguishing effect so as to improve the ignitability, and at the same time, enhancing the durability of the center electrode 3 by welding to the noble metal tip 6 to the center electrode 3.

[0028] In addition to the noble tip 6 welded to the center electrode 3, an additional noble metal tip 6a can be welded to the front firing side surface 5a of the outer electrode 5 as shown at the upper position in Fig. 9. In this instance, the noble tip 6a is made of Pt, Ir, Pt-Ir based alloy or Pt-Ni based alloy.

[0029] With the noble metal tip 6a thus welded to the front firing side surface 5a of the outer electrode 5, it is possible to increase the durability of the outer electrode 5. In this occasion, it stands as a matter of course that in the first through fourth embodiments of the invention, the noble metal tip may be solely welded to the front end surface 3a of the center electrode 3 or the front firing side surface 5a of the outer electrode 5.

[0030] Figs. 10a and 10b show an example of a spark plug, not according to the claimed invention, in which two outer electrodes 5, 5 are provided diametrically opposed with the center electrode 3 interposed therebetween. In this instance, each of the outer electrodes 5, 5 turned toward the center electrode 3 so that the front firing end 5e of the outer electrode 5 faces an elevational side 3s of the center electrode 3. The front firing end 5e of the outer electrode 5 is formed into a bight-shaped notch to be located in concentric relationship with the

center electrode 3. The front firing end 5e serves as a front firing end surface which cooperates with the elevational side 3s of the center electrode 3 so as to form the spark gap G whose width dimension is substantially uniform in both lateral and vertical directions, thus preventing the spark erosion from occurring locally on a limited area so as to impart the spark-erosion resistancy with the center electrode 3.

[0031] Figs. 11a and 11b show a fifth embodiment of the invention in which two outer electrodes 5, 5 are provided diametrically opposed with the center electrode 3 interposed therebetween in the same manner as described in the fourth embodiment of the invention. Each of the outer electrodes 5, 5 turned toward the center electrode 3 so that the front firing end 5e of the outer electrode 5 faces the elevational side of the center electrode 3. However, the front firing end 5e of the outer electrode 5 is formed into a flat-shaped configuration as shown in Fig. 11a. The front firing end 5e serves as a front firing end surface which cooperates with the elevational side 3s of the center electrode 3 so as to form the spark gap G whose width dimension progressively increases from the center to right and left directions, thus making it possible to lessen the flame extinguishing effect which impedes the flame core to develop so as to enhance the ignitability. It is observed that in the fifth embodiment of the invention, the cross section of the outer electrode 5 may be a semi-circular, elliptical or polygonal shape whose corners are rounded to have a radius of 0.5 mm or more.

[0032] Fig. 12 shows a sixth embodiment of the invention in which one of two outer electrodes 5i, 5j forms a spark gap Gi with the front end surface 3a of the center electrode 3, and the other outer electrode 5j is located at its front firing end 5e to form a spark gap Gj with the elevational side 3s in the same manner as described in the fifth embodiment of the invention. In this instance, the cross section of the front firing end 5e of the outer electrode 5j may have the bight-shaped notch or flat-shaped configuration in the same manner as described respectively with reference to Figures 10 and 11.

[0033] Fig. 13 shows a seventh embodiment of the invention in which a projected length (L) of the center electrode 3 is increased so as to form a so-called projected type spark plug. The projected length (L) signifies an axial dimension in which the front end surface 3a of the center electrode 3 extends from a wall portion 7 of a combustion chamber Ci toward a center of the combustion chamber Ci of the internal combustion engine. In this instance, the projected length (L) is predetermined to be 5 mm or more.

[0034] It is preferable to employ the outer electrode 5 to the projected type spark plug which is intended to burn the rarefied fuel gas. With the result of employing the outer electrode 5 to the projected type spark plug, it is possible to significantly improve the ignitability, while at the same time, lessening the variation of the ignitability depending on which side the outer electrode 5 is

oriented when installing the spark plug on the cylinder head of the internal combustion engine. This is all the more effective particularly when running the internal combustion engine with the lean burning operation which is strongly influenced by the swirls caused from intaking the air-fuel mixture. By forming the outer electrode 5 into the composite structure having clad and core, it is possible to increase the heat-drawing action of the outer electrode 5 so as to significantly improve its durability leading to an extended service life.

[0035] In the outer electrode 5 as described in the first through seventh embodiments of the invention, the cross section of the outer electrode 5 may be a circular, semi-circular, elliptical or polygonal shape whose corners are rounded to have a radius of 0.5 mm or more at a portion ahead of a base in which the outer electrode 5 is connected to the front end 4a of the metallic shell 4. In an eighth embodiment of the invention, the cross-section of the outer electrode 5 is formed into a rectangular shape at the base in which the outer electrode 5 is connected to the front end 4a of the metallic shell 4.

[0036] With the cross section of the outer electrode 5 as rectangular only at the base in which the outer electrode 5 is connected to the front end 4a of the metallic shell 4, it is possible to enlarge a welding area of the outer electrode 5 against the metallic shell 4 so as to strengthen a union therebetween, and the same time, ameliorating the heat-drawing action through the metallic shell 4 so as to increase the durability of the outer electrode 5. This is all the more effective particular when a thickness of the front end 4a of the metallic shell 4 is reduced by enlarging an annular space between an inner wall of the metallic shell 4 and a leg portion of the insulator 2 in order to resist against carbon fouling deposited on the insulator 2. This also holds true when applied to a thickness-reduced type spark plug since the thickness of the front end 4a of the metallic shell 4 tends to be reduced with the decrease of a diametrical dimension of a male thread portion provided on the metallic shell 4.

[0037] It is noted that the present invention may be applied to a multi-polarity type spark plug in which a plurality of outer electrodes are provided so that the number of the outer electrodes is three, four, five or more.

[0038] While the invention has been described with reference to the specific embodiments, it is understood that this description is not to be construed in a limiting sense in as much as various modifications and additions to the specific embodiments may be made by skilled artisans without departing from the scope of the invention.

Claims

1. A spark plug (1) comprising:

- an insulator (2) having an axial bore (2a);
- a center electrode (3) placed within the axial

- bore (2a) of the insulator (2), a front end portion of the center electrode (3) extending beyond a front end (2b) of the insulator (2); a metallic shell (4) supporting the insulator (2) so that the front end (2b) of the insulator (2) extends from a front end (4a) of the metallic shell (4); and at least one outer electrode (5;5i,5j) connected to the front end (4a) of the metallic shell (4) to form a spark gap (G;Gi,Gj) with the front end portion of the center electrode (3); wherein the firing surface (5a;5e) of said at least one outer electrode (5;5i,5j) is formed into a flat-shaped configuration to provide the spark gap (G;Gi,Gj) with the front end portion of the center electrode (3); characterised in that the outer surface (5g;R) of a portion of said at least one outer electrode (5;5i,5j) ahead, of a base portion of said at least one outer electrode is formed to have a smoothly curved profile which is not angular and is without any corner edges.
2. A spark plug according to claim 1, having at least one outer electrode (5;5j) forming a spark gap (G; Gj) with an elevational side (3s) of the center electrode (3).
 3. A spark plug according to claim 2, wherein the or each outer electrode (5;5j) which forms a spark gap (G;Gj) with the elevational side (3s) of the center electrode (3) has a front firing end (5e) formed into a flat-shaped configuration.
 4. A spark plug according to claim 2 or 3, wherein the or each outer electrode (5;5j) which forms a spark gap (G;Gj) with the elevational side (3s) of the center electrode (3) has a front firing end (5e) formed into a bight-shaped notch corresponding to the elevational side curvature of the center electrode (3).
 5. A spark plug according to any one of the preceding claims, wherein the cross-section of at least one outer electrode (5;5i,5j) is a circular, semi-circular, elliptical or polygonal shape having corners rounded to have a radius of 0.5 mm or more.
 6. A spark plug according to any one of the preceding claims, wherein the cross-section of the front portion of at least one outer electrode (5;5i,5j) is formed into a semi-circular or polygonal shape whose corners are rounded to have a radius of 0.5 mm or more, while the cross-section of the other portion of the at least one outer electrode (5;5i,5j) except for the front portion is formed into a circular, semi-circular, elliptical or polygonal shape whose corners are rounded to have a radius of 0.5 mm or more.
 7. A spark plug according to any one of claims 1 to 4, wherein the outer surface of at least one outer electrode (5;5i,5j) formed by a smoothly curved profile is located at a portion ahead of a base portion of said at least one outer electrode by which said outer electrode (5;5i,5j) is connected to the metallic shell (4).
 8. A spark plug according to claim 7, wherein the cross-section of the portion ahead of a base portion by which the outer electrode (5;5i,5j) is connected to the metallic shell (4), is formed into a circular, semi-circular, elliptical or polygonal shape whose corners are rounded to have a radius of 0.5 mm or more.
 9. A spark plug according to any one of the preceding claims, wherein the front end surface of the center electrode is adapted to extend into a combustion chamber (Ci) from a wall of the combustion chamber by 5 mm or more.
 10. A spark plug according to any one of the preceding claims, wherein the at least one outer electrode (5; 5i,5j) has a copper or copper-based core (5c).
 11. A spark plug according to any one of the preceding claims, wherein a noble metal tip or noble metal based tip (6a) is at least partly provided on a portion at which the at least one outer electrode (5;5i,5j) forms the spark gap (G;Gi,Gj) with the center electrode (3).
 12. A spark plug according to any one of the preceding claims, wherein the center electrode (3) has a noble metal tip or noble metal based tip (6) at a front firing end which forms the spark gap (G;Gi,Gj) with the at least one outer electrode (5;5i,5j).

Patentansprüche

1. Zündkerze (1), umfassend:

einen Isolator (2) mit einer Axialbohrung (2a);

eine Mittelelektrode (3) innerhalb der Axialbohrung (2a) des Isolators (2), wobei ein vorderer Stirnteil der Mittelelektrode (3) sich über ein stirnseitiges Ende (2b) des Isolators (2) hinaus erstreckt;

eine metallische Hülse (4), die den Isolator (2) in der Weise lagert, daß das stirnseitige Ende (2b) des Isolators (2) sich über ein stirnseitiges Ende (4a) der metallischen Hülse (4) hinaus erstreckt; und

mindestens eine Außenelektrode (5; 5i, 5j), die mit dem stirnseitigen Ende (4a) der metallischen Hülse (4) verbunden ist, um mit dem vorderen Stirnteil der Mittelelektrode (3) eine Funkenstrecke (G; Gi, Gj) zu bilden;

wobei die Zündfläche (5a; 5e) der mindestens einen Außenelektrode (5; 5i, 5j) mit flacher Gestalt ausgebildet ist, um die Funkenstrecke (G; Gi, Gj) mit dem stirnseitigen Endteil der Mittelelektrode (3) zu bilden, **dadurch gekennzeichnet**, daß

die Außenfläche (5g; R) eines Teils der mindestens einen Außenelektrode (5; 5i, 5j), der vor einem Basisteil der mindestens einen Außenelektrode liegt, mit einem glatt gekrümmten Profil ohne Winkel und ohne Eckkanten ausgebildet ist.

2. Zündkerze nach Anspruch 1 mit mindestens einer Außenelektrode (5; 5j), die mit einer Seitenfläche (3s) der Mittelelektrode (3) eine Funkenstrecke (G; Gj) bildet.
3. Zündkerze nach Anspruch 2, bei der die oder jede Außenelektrode (5; 5j), die mit der Seitenfläche (3s) der Mittelelektrode (3) eine Funkenstrecke (G; Gj) bildet, ein vorderes Zündende (5a) aufweist, welches mit flacher Gestalt ausgebildet ist.
4. Zündkerze nach Anspruch 2 oder 3, bei der die oder jede Außenelektrode (5; 5j), die mit der Seitenfläche (3s) der Mittelelektrode (3) eine Funkenstrecke (G; Gj) bildet, ein vorderes Zündende (5e) in Form einer buchtähnlichen Kerbe entsprechend der Seitenflächenkrümmung der Mittelelektrode (3) aufweist.
5. Zündkerze nach einem der vorhergehenden Ansprüche, bei der der Querschnitt zumindest einer Außenelektrode (5; 5i, 5j) kreisförmig, halbkreisförmig, elliptisch oder polygonförmig mit abgerundeten Ecken eines Radius' von 0,5 mm oder mehr ausgebildet ist.
6. Zündkerze nach einem der vorhergehenden Ansprüche, bei der der Querschnitt des Vorderteils mindestens einer Außenelektrode (5; 5i, 5j) halbkreisförmig oder polygonförmig ausgebildet ist, wobei die Ecken der Ausbildung mit einem Radius von 0,5 mm oder mehr abgerundet sind, während der Querschnitt des übrigen Teils der mindestens einen Außenelektrode (5; 5i, 5j) mit Ausnahme des vorderen Teils kreisförmig, halbkreisförmig, elliptisch oder polygonförmig ausgebildet ist, wobei die Ecken mit einem Radius von 0,5 mm oder mehr abgerundet sind.

7. Zündkerze nach einem der Ansprüche 1 bis 4, bei der die Außenfläche der mindestens einen Außenelektrode (5; 5i, 5j) mit einem glatt gekrümmten Profil sich in einem Abschnitt vor einem Basisteil der mindestens einen Außenelektrode befindet, über den die Außenelektrode (5; 5i, 5j) mit der metallischen Hülse (4) verbunden ist.
8. Zündkerze nach Anspruch 7, bei der der Querschnitt des Teils vor dem Basisteil, über den die Außenelektrode (5; 5i, 5j) mit der metallischen Hülse (4) verbunden ist, kreisförmig, halbkreisförmig, elliptisch oder polygonförmig ausgebildet ist, wobei die Ecken der Ausbildung mit einem Radius von 0,5 mm oder mehr abgerundet sind.
9. Zündkerze nach einem der vorhergehenden Ansprüche, bei der die vordere Stirnfläche der Mittelelektrode so ausgebildet ist, daß sie sich von einer Wand einer Verbrennungskammer um 5 mm oder mehr in die Verbrennungskammer (Ci) hinein erstreckt.
10. Zündkerze nach einem der vorhergehenden Ansprüche, bei der die mindestens eine Außenelektrode (5; 5i, 5j) einen Kern (5c) aus Kupfer oder einem Material auf Kupferbasis aufweist.
11. Zündkerze nach einem der vorhergehenden Ansprüche, bei der an einem Abschnitt, an dem die mindestens eine Außenelektrode (5; 5i, 5j) mit der Mittelelektrode (3) die Funkenstrecke (G; Gi, Gj) bildet, eine Edelmetallspitze oder eine Spitze (6a) aus Material auf Edelmetallbasis zumindest teilweise vorgesehen ist.
12. Zündkerze nach einem der vorhergehenden Ansprüche, bei der die Mittelelektrode (3) an dem vorderen Zündende, welches mit der mindestens einen Außenelektrode (5; 5i, 5j) die Funkenstrecke (G; Gi, Gj) bildet, eine Edelmetallspitze oder eine Spitze (6) aus Material auf Edelmetallbasis aufweist.

45 Revendications

1. Bougie d'allumage (1) comportant :

un isolant (2) ayant un alésage axial (2a),
 une électrode centrale (3) placée à l'intérieur de l'alésage (2a) de l'isolant (2), une partie d'extrémité avant de l'électrode centrale (3) s'étendant au-delà d'une extrémité avant (2b) de l'isolant (2),
 une enveloppe métallique (4) supportant l'isolant (2) de telle sorte que l'extrémité avant (2b) de l'isolant (2) s'étend à partir d'une extrémité avant (4a) de l'enveloppe métallique (4), et

- au moins une électrode extérieure (5 ; Si, 5j) reliée à l'extrémité avant (4a) de l'enveloppe métallique (4) pour former un intervalle de décharge (G ; Gi, Gj) avec la partie d'extrémité avant de l'électrode centrale (3), dans laquelle la surface d'amorçage (5a ; 5e) de ladite au moins une électrode extérieure (5 ; 5i, 5j) est formée en une configuration de forme plate pour fournir l'intervalle de décharge (G ; Gi, Gj) avec la partie d'extrémité avant de l'électrode centrale (3), caractérisée en ce que la surface extérieure (5g ; R) d'une partie de ladite au moins une électrode extérieure (5 ; 5i, 5j) située en avant d'une partie de base de ladite au moins une électrode extérieure est formée pour avoir un profil légèrement incurvé qui n'est pas anguleux, et qui est sans aucun bord formant coin.
2. Bougie d'allumage selon la revendication 1, ayant au moins une électrode extérieure (5 ; 5j) formant l'intervalle de décharge (G ; Gj) avec un côté de hauteur (3s) de l'électrode centrale (3).
 3. Bougie d'allumage selon la revendication 2, dans laquelle la ou chaque électrode extérieure (5 ; 5j) qui forme l'intervalle de décharge (G ; Gj) avec le côté de hauteur (3s) de l'électrode centrale (3) a une extrémité d'amorçage avant (5e) formée en une configuration de forme plate.
 4. Bougie d'allumage selon la revendication 2 ou 3, dans laquelle la ou chaque électrode extérieure (5 ; 5j) qui forme l'intervalle de décharge (G ; Gj) avec le côté de hauteur (3s) de l'électrode centrale (3) a l'extrémité d'amorçage avant (5e) formée en encoche en forme d'anse correspondant à la courbure du côté de hauteur de l'électrode centrale (3).
 5. Bougie d'allumage selon l'une quelconque des revendications précédentes, dans laquelle la coupe transversale de la au moins une électrode extérieure (5 ; Si, 5j) est de forme circulaire, semi-circulaire, elliptique ou polygonale ayant des coins arrondis pour avoir un rayon de 0,5 mm ou plus.
 6. Bougie d'allumage selon l'une quelconque des revendications précédentes, dans laquelle la coupe transversale de la partie avant de la au moins une électrode extérieure (5 ; 5i, 5j) est formée en une forme semi-circulaire ou polygonale dont les coins sont arrondis pour avoir un rayon de 0,5 mm ou plus, alors que la coupe transversale de l'autre partie de la au moins une électrode extérieure (5 ; 5i, 5j), exceptée la partie avant, est formée en une forme circulaire, semi-circulaire, elliptique ou polygonale, dont les coins sont arrondis pour avoir un rayon de 0,5 mm ou plus.
 7. Bougie d'allumage selon l'une quelconque des revendications 1 à 4, dans laquelle la surface extérieure de la au moins une électrode extérieure (5 ; 5i, 5j) formée par un profil incurvé lisse est positionnée au niveau d'une partie située en avant de la partie de base de ladite au moins une électrode extérieure par laquelle ladite électrode extérieure (5 ; 5i, 5j) est reliée à l'enveloppe métallique (4).
 8. Bougie d'allumage selon la revendication 7, dans laquelle la coupe transversale de la partie située en avant de la partie de base par laquelle l'électrode extérieure (5 ; 5i, 5j) est reliée à l'enveloppe métallique (4), est formée en une forme circulaire, semi-circulaire, elliptique ou polygonale, dont les coins sont arrondis pour avoir un rayon de 0,5 mm ou plus.
 9. Bougie d'allumage selon l'une quelconque des revendications précédentes, dans laquelle la surface d'extrémité avant de l'électrode centrale est adaptée pour s'étendre dans une chambre de combustion (Ci) à partir d'une paroi de la chambre de combustion sur 5 mm ou plus.
 10. Bougie d'allumage selon l'une quelconque des revendications précédentes, dans laquelle la au moins une électrode extérieure (5 ; 5i, 5j) a un noyau en cuivre ou à base de cuivre (5c).
 11. Bougie d'allumage selon l'une quelconque des revendications précédentes, dans laquelle un embout de métal noble ou un embout à base de métal noble (6a) est au moins partiellement agencé sur la partie au niveau de laquelle la au moins une électrode extérieure (5 ; 5i, 5j) forme l'intervalle de décharge (G ; Gi, Gj) avec l'électrode centrale (3).
 12. Bougie d'allumage selon l'une quelconque des revendications précédentes, dans laquelle l'électrode centrale (3) a un embout de métal noble ou un embout à base de métal noble (6) au niveau de l'extrémité d'amorçage avant qui forme l'intervalle de décharge (G ; Gi, Gj), avec la au moins une électrode extérieure (5 ; 5i, 5j).

Fig. 1

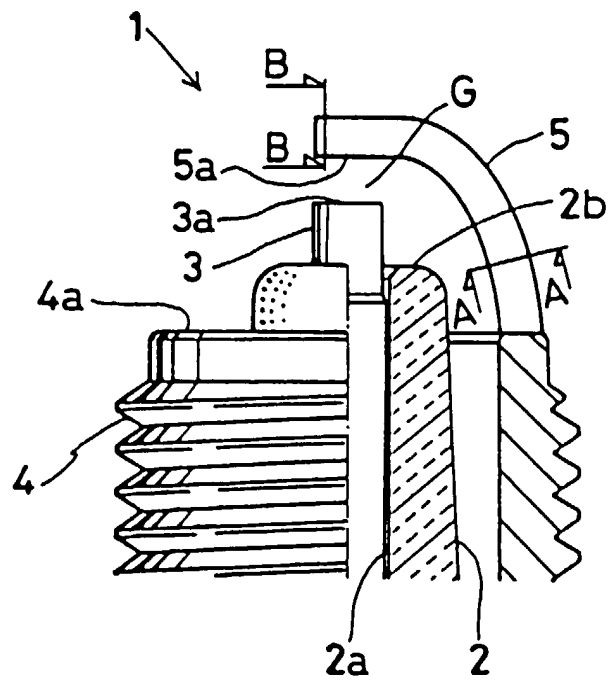

Fig. 2

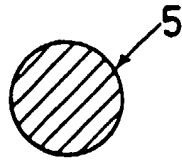

Fig. 3a

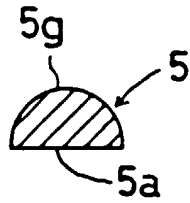

Fig. 3b

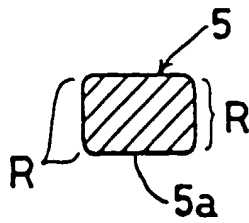

Fig. 4a

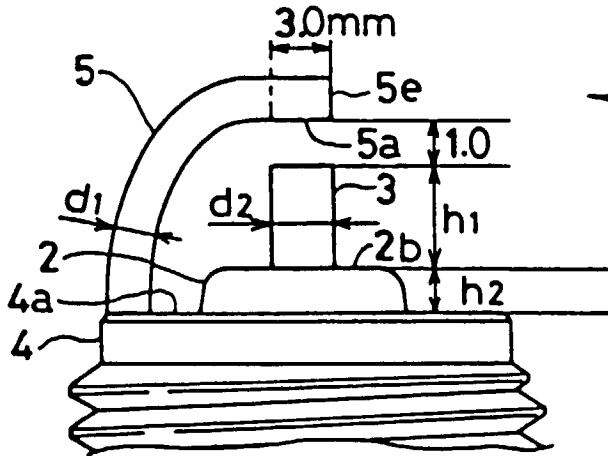

Fig. 4b

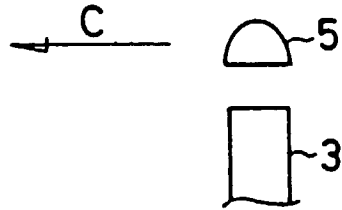

Fig. 5a

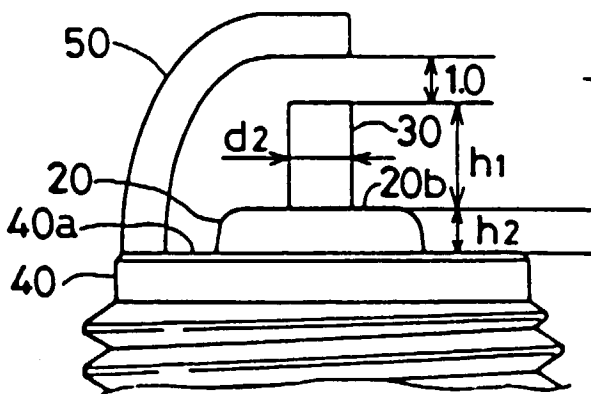

Fig. 5b

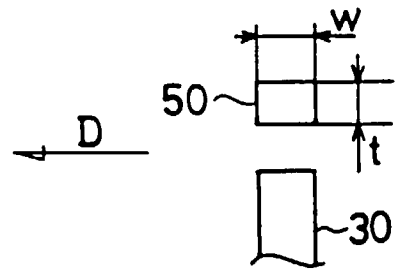
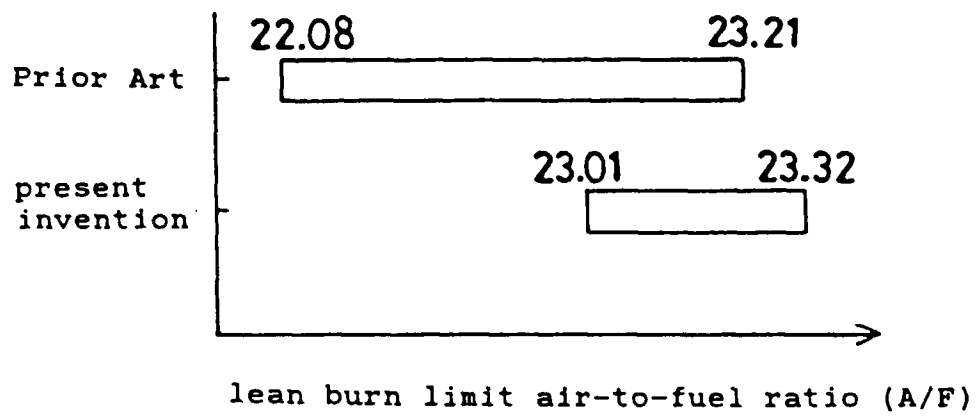

Fig. 6



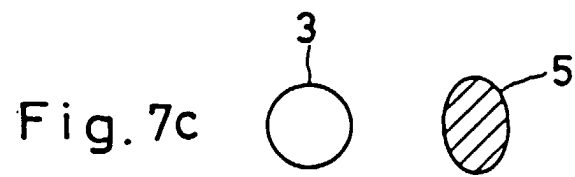
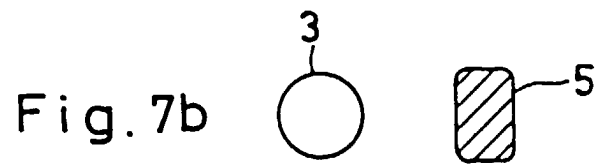
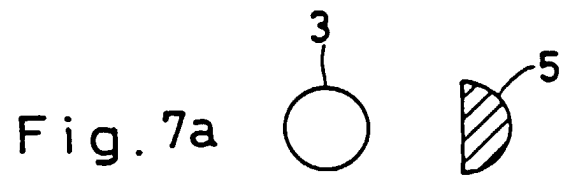

Fig. 8

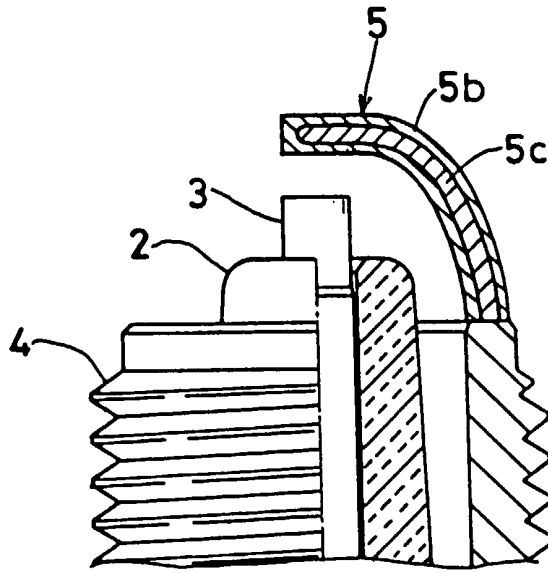
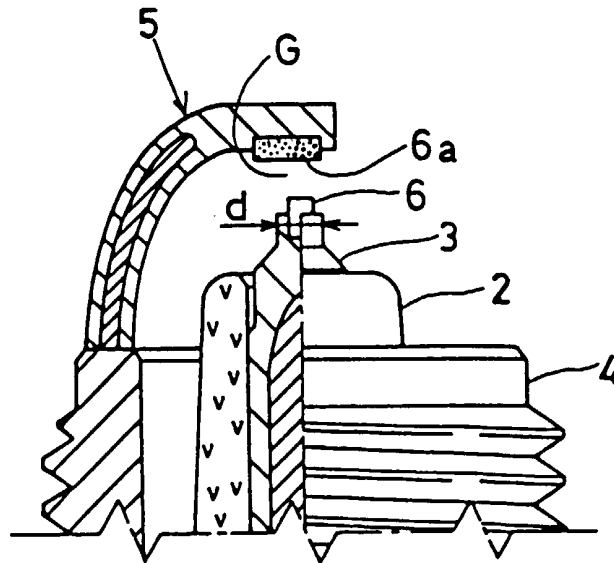

Fig. 9



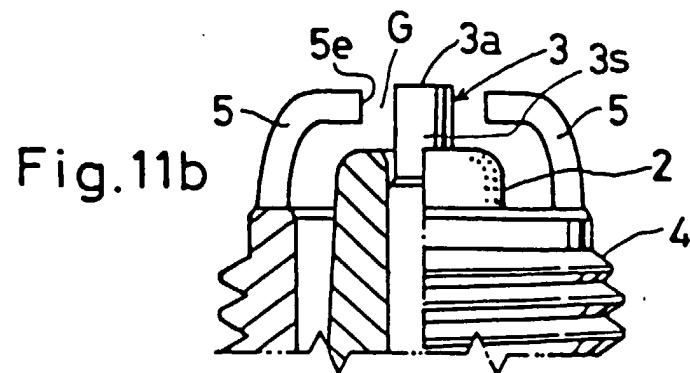
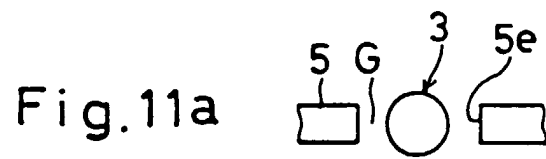
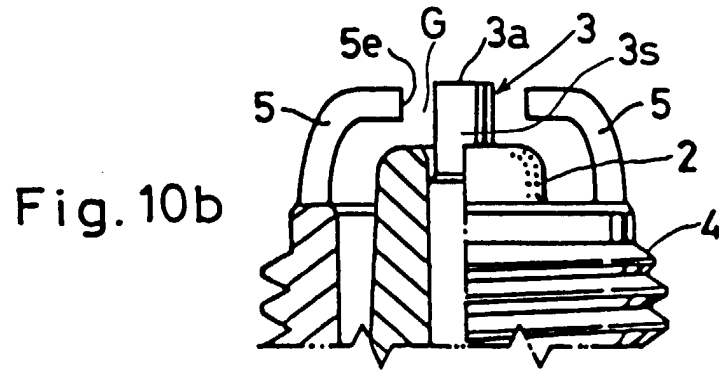
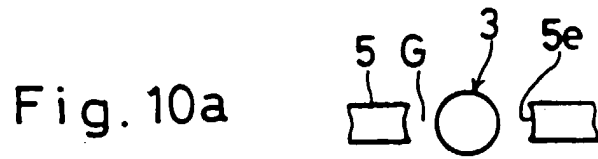

Fig. 12

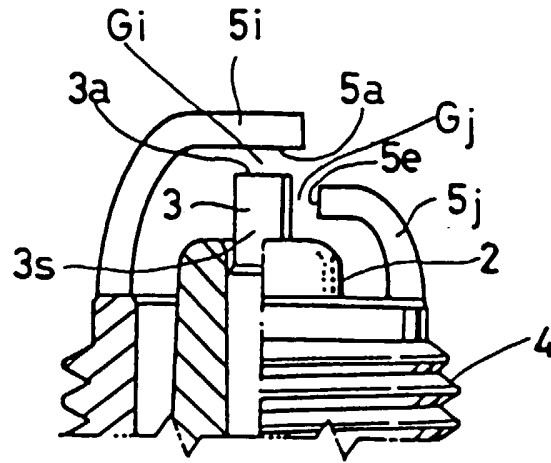

Fig. 13

~Ci~

