



(12) EUROPEAN PATENT APPLICATION

(43) Date of publication:
28.08.1996 Bulletin 1996/35

(51) Int. Cl.⁶: B21B 35/14

(21) Application number: 96102538.4

(22) Date of filing: 20.02.1996

(84) Designated Contracting States:
DE FR GB

(72) Inventor: **Kawasaki, Toshinobu**,
c/o Koyo Seiko Co., Ltd.
Osaka 542 (JP)

(30) Priority: 22.02.1995 JP 34040/95

(74) Representative: **MEISSNER, BOLTE & PARTNER**
Patentanwälte
Postfach 86 06 24
81633 München (DE)

(71) Applicant: **KOYO SEIKO CO., LTD.**
Chuo-ku Osaka 542 (JP)

(54) Shaft coupling mechanism

(57) A shaft coupling mechanism of the present invention includes a rotary shaft (21) and a rotary cylinder (3b) which are engaged with each other for transmission of a torque in a state where a predetermined phase shift therebetween is permitted. A first clearance which is to be reduced according to a phase shift between the shaft (21) and the cylinder (3b) and a second clearance which is always constant regardless of the phase shift are provided between the shaft (21) and the cylinder (3b). The mechanism further includes a hydraulic mechanism (36a, 40, 60, 36b, 50) for transforming a force applied as fluid pressure for reducing the first clearance into a force for retaining the shaft (21) in the second clearance. In the hydraulic mechanism, when first plungers (40) are respectively pushed by flat surfaces (22A) of the shaft (21), second plungers (50) respectively press curved surfaces (22B) of the shaft (21), thereby causing the shaft (21) to be coupled to the cylinder (3b). If the phases of the shaft (21) and the cylinder (3b) coincide with each other when the shaft (21) is not driven, the shaft (21) which has been held by the second plungers (50) is released, thereby allowing the attachment and detachment of the shaft (21).

FIG. 1

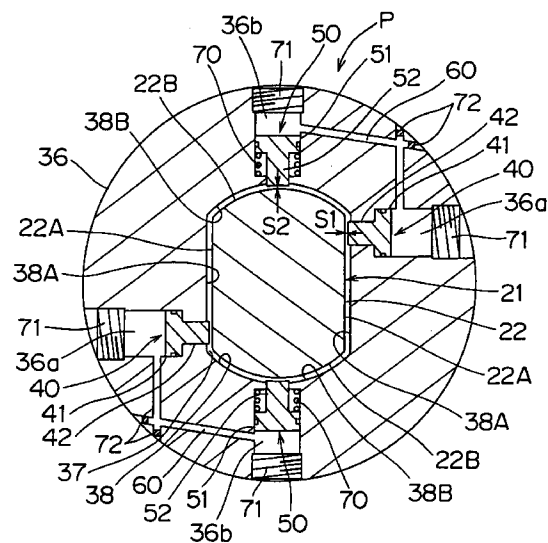

Description**BACKGROUND OF THE INVENTION****Field of the Invention**

The present invention relates to a shaft coupling mechanism for coupling a rotary shaft to a rotary cylinder.

Description of Related Arts

One exemplary shaft coupling mechanism is a roll coupling device wherein a roll shaft of a roll is inserted into an engagement opening formed in a roll coupling of a universal joint for a rolling mill. To facilitate the attachment and detachment of the roll for replacement thereof, the roll shaft is coupled to the engagement opening with a clearance provided therebetween in a so-called loose-fitting manner.

However, vibration resulting from the clearance may produce adverse effects such as chatter marks and undulation of a rolled product. In particular, the vibration is a critical problem for a rolling mill such as a cold rolling mill which requires high accuracy.

To eliminate the aforesaid problem due to the clearance, various coupling mechanisms are proposed in which, after a roll shaft of a roll is inserted into an engagement opening, the roll is coupled to a coupling with a hydraulic force generated by supplying an high-pressure oil into an oil chamber defined by the roll shaft and the coupling (see Japanese Unexamined Patent Publication No.6-137338 (1994) and Japanese Examined Patent Publication No.2-5931 (1990)).

However, the coupling mechanisms disclosed in the aforesaid publications suffer the following problems (1) to (3):

- (1) A process for applying a hydraulic pressure is required after the roll shaft of the roll is inserted into the engagement opening, thereby increasing the number of process steps;
- (2) Oil chamber sealing, hydraulic oil piping, a hydraulic pump and the like are required, thereby complicating the construction of the coupling mechanism and substantially increasing the production cost; and
- (3) The oil chamber and other structures required for the oil supply are arranged around the roll shaft, thereby increasing diametrical and axial dimensional requirements for the roll.

Above problems can be found not only in the rotary shaft of a roll but also in various kinds of shaft coupling mechanism.

SUMMARY OF THE INVENTION

It is an object of the present invention to provide a compact and inexpensive coupling mechanism that facilitates the attachment and detachment of a rotary shaft and eliminates vibration of the rotary shaft which would otherwise occur during the driving of the rotary shaft.

In accordance with one preferred mode of the present invention to achieve the aforesaid object, there is provided a shaft coupling mechanism including a rotary shaft and a rotary cylinder which are engaged with each other for transmission of a torque in a state where a predetermined phase shift therebetween is permitted, wherein a first clearance provided between the rotary shaft and the rotary cylinder is adapted to be reduced according to a phase shift between the rotary shaft and the rotary cylinder, and a second clearance provided between the rotary shaft and the rotary cylinder is always constant regardless of the phase shift. The shaft coupling mechanism further includes a hydraulic mechanism for transforming a force applied as fluid pressure for reducing the first clearance into a force for retaining the rotary shaft in the second clearance.

In this mode, the force for retaining the rotary shaft in the second clearance is increased by the action of the hydraulic mechanism when the first clearance is reduced according to the phase shift produced between the rotary shaft and the rotary cylinder during the driving of the rotary shaft. Thus, the rotary shaft is firmly coupled to the rotary cylinder. On the other hand, when the rotary shaft is not driven, the reduction of the first clearance is readily canceled to reduce the force for retaining the rotary shaft in the second clearance, thereby allowing easy attachment and detachment of the rotary shaft. Thus, the shaft coupling mechanism having a simpler construction, which is more compact and less expensive than the conventional hydraulic coupling devices, can be provided.

In accordance with another preferred mode of the present invention, the rotary shaft has an outer peripheral surface including a pair of flat surfaces disposed opposite to each other and a pair of curved surfaces disposed opposite to each other, and the rotary cylinder has an inner peripheral surface including a pair of first opposed surfaces respectively facing opposite to the pair of flat surfaces with a space including the first clearance interposed therebetween and a pair of second opposed surfaces respectively facing opposite to the pair of the curved surfaces with the second clearance interposed therebetween. The hydraulic mechanism includes first plungers respectively accommodated in first cylinders provided in association with the first opposed surfaces and adapted to approach the flat surfaces when a phase shift occurs, the first plungers are shifted between projected positions and retracted positions where the first plungers are pushed for retraction by the corresponding flat surfaces when the phase shift occurs; second plungers respectively accommodated in

second cylinders provided in association with the second opposed surfaces, the second plungers are shifted between projected positions where the second plungers can press the corresponding curved surfaces and retracted positions where the second plungers are spaced apart from the corresponding curved surfaces; communication paths for allowing the first cylinders to communicate with the corresponding second cylinders to form closed fluid lines; and biasing means for biasing the second plungers toward the retracted positions.

In this mode, when a torque is transmitted during the driving of the rotary shaft, the flat surfaces respectively push the first plungers into the retracted positions in response to the phase shift between the rotary shaft and the rotary cylinder. This allows oil to be supplied to the second cylinders from the first cylinders through the communication paths. As a result, the second plungers respectively press the curved surfaces, so that the rotary shaft is firmly coupled to the rotary cylinder. Thus, the occurrence of vibration can be prevented. On the other hand, where the phases of the rotary shaft and the rotary cylinder coincide with each other when the rotary shaft is not driven, the first plungers which have been pushed by the flat surfaces are released. Thus, the second plungers are pushed back to the retracted positions by the biasing means, and the oil flows back to the first cylinders from the second cylinders. As a result, the first plungers are shifted back to the projected positions. Since the clearances are provided between the flat surfaces and the corresponding first opposed surfaces and between the curved surfaces and the corresponding second opposed surfaces, the rotary shaft can be easily attached or detached when the rotary shaft is not driven. Therefore, the shaft coupling mechanism having a simpler construction, which is more compact and less expensive than the conventional hydraulic coupling devices, can be provided.

In accordance with still another preferred mode of the present invention, the hydraulic mechanism further includes third plungers respectively accommodated in third cylinders provided in association with the first opposed surfaces which are spaced apart from the flat surfaces when the phase shift occurs, the third plungers are shifted between projected positions where the third plungers press the flat surfaces and retracted positions where the third plungers are spaced apart from the flat surfaces; biasing means for biasing the third plungers toward the retracted positions; and communication paths for allowing the third cylinders to communicate with at least either ones of the first cylinders accommodating the first plungers or the second cylinders accommodating the second plungers. In this mode, when the phase shift occurs, the flat surfaces spaced apart from the first opposed surfaces are pressed by the third plungers, so that the rotary shaft is firmly coupled to the rotary cylinder. Therefore, the occurrence of the vibration can be assuredly prevented. On the other hand, when the rotary shaft is not driven, the third plungers

are pushed back to the retracted positions by the biasing means.

In accordance with yet another preferred mode of the present invention, the second cylinders accommodating the second plungers each have a smaller sectional area than that of the first cylinders accommodating the first plungers. In this mode, when the phase shift occurs, the displacement amount of the first plungers can be made greater than the displacement amount of the second plungers, so that the curved surfaces can be more strongly pressed by the second plungers. Therefore, the rotary shaft can be more firmly coupled to the rotary cylinder.

In accordance with still another preferred mode of the present invention, indentations are formed on the first opposed surfaces to increase the phase shift between the rotary shaft and the rotary cylinder. In this mode, the indentations ensure a greater phase shift, thereby increasing the displacement amount of the second plungers. This enables the second plungers to press the curved surfaces more strongly, thereby ensuring more firm coupling of the rotary shaft to the rotary cylinder.

BRIEF DESCRIPTION OF THE DRAWINGS

Fig. 1 is a sectional view illustrating the major portion of a shaft coupling mechanism in accordance with an embodiment of the present invention in a state where no torque is loaded;

Fig. 2 is a sectional view illustrating the major portion of the shaft coupling mechanism in a state where a torque is loaded;

Fig. 3 is a partial plan view illustrating the major portion of a rolling mill including the shaft coupling mechanism;

Fig. 4 is a partial plan view illustrating a coupling;

Fig. 5 is a sectional view illustrating the major portion of the shaft coupling mechanism in a state where no torque is loaded;

Fig. 6 is a sectional view illustrating the major portion of the shaft coupling mechanism in a state where a torque is loaded;

Fig. 7 is a sectional view illustrating the major portion of the shaft coupling mechanism functioning when a roll is rotated in a reverse direction in a state where no torque is loaded;

Fig. 8 is a sectional view illustrating the major portion of the shaft coupling mechanism functioning when the roll is rotated in a reverse direction in a state where a torque is loaded;

Fig. 9 is a sectional view illustrating the major portion of a shaft coupling mechanism in accordance with a second embodiment of the present invention;

Fig. 10 is a sectional view illustrating the major portion of a shaft coupling mechanism in accordance with a third embodiment of the present invention;

Fig. 11 is a sectional view illustrating the major portion of a shaft coupling mechanism in accordance

with a fourth embodiment of the present invention in a state where no torque is loaded;

Fig. 12 is a sectional view illustrating the major portion of the shaft coupling mechanism shown in Fig. 11 in a state where a torque is loaded;

Fig. 13 is a sectional view illustrating the major portion of the shaft coupling mechanism in accordance with a fifth embodiment of the present invention in a state where no torque is loaded; and

Fig. 14 is a sectional view illustrating the major portion of the shaft coupling mechanism shown in Fig. 13 in a state where a torque is loaded.

DETAILED DESCRIPTION OF THE PREFERRED EMBODIMENTS

With reference to the attached drawings, the present invention will hereinafter be described in detail by way of embodiments thereof.

Referring to Fig. 3, a drive shaft 1 driven by a power unit such as a rolling motor is coupled to one end 3a of a coupling 3. A roll shaft 21 of a roll 2 is coupled to an engagement opening 37 formed at the other end 3b of the coupling 3. The coupling mechanism serves to couple the roll shaft 21 of the roll 2 to the engagement opening 37 of the coupling 3.

As shown in Fig. 4, the coupling 3 includes: (1) a driving-side fitting yoke 31 coupled to the drive shaft 1; (2) a universal joint 32 for alignment coupled to the driving-side fitting yoke 31 at one end thereof; (3) a spline shaft joint 6 coupled to the other end of the universal joint 32; (4) a universal joint 35 for alignment coupled to the spline shaft joint 6 at one end thereof; and (5) a driven-side fitting yoke 36 coupled to the other end of the universal joint 35. The engagement opening 37 for engagement of the roll shaft 21 is formed in the driven-side fitting yoke 36.

The spline shaft joint 6 includes: (1) a driving-side shaft 33 coupled to the other end of the universal joint 32; (2) a driven-side shaft 34 coupled to the universal joint 36 and rotatably united with the driving-side shaft 33; and (3) a spring (not shown) disposed between the driving-side shaft 33 and the driven-side shaft 34 for resiliently biasing the driven-side shaft 34 toward the roll 2.

Referring to Fig. 1 (illustrating a state for roll replacement) and Fig. 2 (illustrating a state for rolling) which are sectional views taken along a line X-X in Fig. 5, the outer peripheral surface 22 of the roll shaft 21 includes a pair of flat surfaces 22A disposed opposite to each other and a pair of curved surfaces 22B disposed opposite to each other. An inner peripheral surface 38 of the engagement opening 37 includes a pair of first opposed surfaces 38A respectively facing opposite to the pair of flat surfaces 22A and a pair of second opposed surfaces 38B respectively facing opposite to the pair of curved surfaces 22B.

As shown in Fig. 1, a clearance provided between the flat surface 22A and the first opposed surface 38A

facing opposite thereto is equivalent to a clearance provided between the curved surface 22B and the second opposed surface 38B facing opposite thereto, when the phases of the roll shaft 21 and the coupling 3 coincide with each other. The clearances permit the attachment and detachment of the roll shaft 21 when no torque is loaded. The clearances are preferably about 0.3mm to about 0.5mm, which are substantially the same as those in the prior art. Even if the wear of rods 42 and 52 of first and second plungers 40 and 50 (which will be described later) disables the second plungers 50 from pressing the curved surfaces 22B, the level of the resulting vibration may not be aggravated as much as in the prior art.

Referring to Fig. 5 (which illustrates the state for roll replacement), shaft coupling mechanisms P and shaft coupling mechanisms Q are alternately disposed at predetermined intervals along an axis of the driven-side fitting yoke 36. The shaft coupling mechanisms P and Q are adapted to couple the roll shaft 21 to the coupling 3 when the roll shaft is rotated in a normal direction as shown in Fig. 1 and in a reverse direction as shown in Fig. 8, respectively. The construction of the shaft coupling mechanism P (see Fig. 1) is such that the construction of the shaft coupling mechanism Q (see Fig. 7) is laterally reversed.

The shaft coupling mechanisms P each include: (1) first plungers 40 respectively disposed in association with the first opposed surfaces 38A, the first plungers 40 are adapted to approach the flat surfaces 22A when the phase shift occurs, and to shift between projected positions as shown in Fig. 1 and retracted positions as shown in Fig. 2; (2) second plungers 50 respectively disposed in association with the second opposed surfaces 38B, the second plungers 50 are adapted to shift between projected positions as shown in Fig. 2 and retracted positions as shown in Fig. 1; (3) communication paths 60 for allowing the first plungers 40 to communicate with the corresponding second plungers 50; and (4) compression coil springs 70 serving as biasing means for biasing the second plungers 50 toward the retracted positions.

Oil flowing back and forth between the first and second plungers 40 and 50 through the communication path 60 communicating with the first and second plungers 40 and 50 allows either one of the first plunger 40 and the second plunger 50 to be located in the retracted position with the other being located in the projected position as shown in Figs. 1 and 2.

The first and second plungers 40 and 50 respectively include: (1) pistons 41 and 51 slidably accommodated in first and second cylinders 36a and 36b defined by the openings formed in the driven-side fitting yoke 36; and (2) rods 42 and 52 slidably accommodated in through-holes extending from the cylinders 36a and 36b to the engagement opening 37. O-rings for sealing are fitted in annular grooves formed on outer peripheral surfaces of the pistons 41 and 42.

Ends of the rods 52 of the second plungers 50 are concaved so as to be fitted onto the curved surfaces 22B of the roll shaft 21.

As shown in Fig. 1, the clearance S1 provided between the end of the rod 42 of the first plunger 40 and the flat surface 22A of the roll shaft 21 is equivalent to the clearance S2 provided between the end of the rod 52 of the second plunger 50 and the curved surface 22B of the roll shaft 21 when the phases of the roll shaft 21 and the coupling 3 coincide with each other. The first cylinder 36a has the same sectional area as the second cylinder 36b.

The first and second cylinders 36a and 36b and the communication paths 60 are sealed with screw stoppers 71 and sealing stoppers 72, respectively, and the oil is charged in the first and second cylinders 36a and 36b and the communication paths 60.

The construction of the shaft coupling mechanism Q for reverse rotation of the roll shaft 21 is substantially the same as the shaft coupling mechanism P when the construction of the shaft coupling mechanism P is laterally reversed as described above. Therefore, like reference numerals are assigned to like components of the shaft coupling mechanism P in Figs. 5 to 8, and an explanation for such components is omitted.

The operation of the shaft coupling mechanism P (see Fig. 6) for normal rotation of the roll shaft will next be described. When a torque is transmitted during the driving of the roll shaft 21, the phase shift between the roll shaft 21 and the coupling 3 occurs as shown in Fig. 2, so that the flat surfaces 22A push the first plungers 40 which are retracted to the retracted positions. Hence, the oil flows from the first plungers 40 to the second plungers 50 through the communication paths 60, whereby the second plungers 50 press the corresponding curved surfaces 22B. As a result, the roll shaft 21 is coupled to the coupling 3. Since the clearances S1 and S2 are equal to each other and the sectional areas of the first and second cylinders 36a and 36b are also equal to each other, the curved surfaces 22B are tightly secured by the pairs of second plungers 50 with no interference provided therebetween. On the other hand, if the phases of the roll shaft 21 and the coupling 3 coincide with each other when the roll shaft 21 is not driven as shown in Fig. 1, the first plungers 40 which have been pushed by the flat surfaces 22A are released. Hence, the second plungers 50 are pushed back to the retracted positions by the compression coil springs 70, whereby the oil flows back to the first plungers 40 from the second plungers 50. As a result, the first plungers 40 are returned to the projected positions.

In accordance with this embodiment, since the clearances are formed around the roll shaft 21 when the roll shaft is not driven, the roll shaft 21 can be readily attached or detached to/from the engagement opening 37. When the roll shaft 21 is driven, the second plungers 50 press the curved surfaces 22B, whereby the roll shaft 21 is coupled to the coupling 3 so that the occurrence of the vibration can be prevented. Thus, the shaft coupling

mechanism having a simple construction, which is more compact and less expensive than the conventional hydraulic coupling devices, can be provided.

Since the shaft coupling mechanisms P are axially spaced predetermined distances from each other as shown in Figs. 5 and 6, the roll shaft 21 is assuredly prevented from being inclined with respect to the axis of the engagement opening 37.

The prior art in which a torque is loaded after the roll shaft is tightly secured in the engagement opening requires a spline structure for adjusting the length of the coupling to accommodate vertical fluctuation of the roll. In accordance with this embodiment, however, the adjustment of the length of the coupling 3 is not necessary because the roll shaft 21 is slightly drawn from the engagement opening 37 when the loading of a torque is started. Therefore, a spline shaft joint 6 may be dispensed with.

For reverse rotation of the roll shaft 21 as shown in Fig. 8, the shaft coupling mechanism Q operates in substantially the same manner as that of the shaft coupling mechanism P for the normal rotation of the roll shaft 21.

Fig. 9 illustrates a second embodiment of the present invention. Referring to Fig. 9, a difference in the construction between the second embodiment and the first embodiment shown in Fig. 1 is that the clearance S2 formed between the rod 52 of the second plunger 50 and the curved surface 22B of the roll shaft 21 is smaller than the clearance S1 formed between the rod 42 of the first plunger 40 and the flat surface 22A of the roll shaft when the phases of the roll shaft 21 and the coupling 3 coincide with each other. In this embodiment, the stroke amounts of the second plungers 50 can be increased in comparison with the first embodiment shown in Fig. 1, whereby the curved surfaces 22B of the roll shaft 21 can be tightly secured by the pairs of second plungers 50 with interferences provided therebetween. Therefore, tighter coupling can be realized.

Fig. 10 illustrates a third embodiment of the present invention. Referring to Fig. 10, a difference in the construction between the third embodiment and the first embodiment shown in Fig. 1 is that the diameter d2 of the second cylinder 36b is smaller than the diameter d1 of the first cylinder 36a. That is, the second cylinder 36b has a smaller sectional area than the first cylinder 36a. In this embodiment, the stroke amounts of the second plungers 50 can be increased in comparison with the first embodiment shown in Fig. 1, whereby the curved surfaces 22B of the roll shaft 21 can be tightly secured by the pairs of second plungers 50 with interferences provided therebetween. Therefore, tighter coupling can be realized.

Figs. 11 and 12 illustrate a shaft coupling mechanism in accordance with a fourth embodiment of the present invention. Fig. 11 shows a state of the shaft coupling mechanism for roll replacement, and Fig. 12 shows a state of the shaft coupling mechanism for rolling (or for the driving of the roll shaft 21). Referring to Figs. 11 and 12, a difference in the construction

between the fourth embodiment and the first embodiment shown in Fig. 1 is that indentations 38C are formed at junctures between the first opposed surfaces 38A and the second opposed surfaces 38B thereby increasing the phase shift between the roll shaft 21 and the coupling.

In accordance with this embodiment, the clearance formed between the flat surface 22A of the roll shaft 21 and the first opposed surface 38A is the same as that in the first embodiment. However, the edge portions of the flat surfaces 22A of the roll shaft 21 enter the indentations 38C, so that the stroke amounts of the first plungers 40 can be increased. As a result, the stroke amounts of the second plungers 50 are increased, thereby allowing the pairs of second plungers 50 to tightly secure the curved surfaces 22B of the roll shaft 21 with interferences provided therebetween. Thus, tighter coupling can be realized.

The clearances provided between the flat surfaces 22A and portions of the first opposed surfaces 38A other than the indented portions 38C are preferably about 0.3mm to about 0.5mm which are substantially the same as those in the prior art. Even if the wear of the rods 42 and 52 of the first and second plungers 40 and 50 disables the second plungers 50 from pressing the curved surfaces 22B, the performance of the shaft coupling mechanism may not be degraded by the resulting vibration as much as in the prior art. It should be noted that two pairs of indentations 38C are provided because the roll 2 is rotated both in a normal direction and in a reverse direction.

Figs. 13 and 14 illustrate a shaft coupling mechanism in accordance with a fifth embodiment of the present invention. Fig. 13 shows a state of the shaft coupling mechanism for roll replacement, and Fig. 14 shows a state of the shaft coupling mechanism for rolling (or for the driving of the roll shaft). Referring to Figs. 13 and 14, differences in the construction between the fifth embodiment and the first embodiment shown in Fig. 1 are that, in the construction of the fifth embodiment, the first opposed surfaces 38A respectively face opposite to the first plungers 40 across the roll shaft 21, and that the shaft coupling mechanism has: (1) third plungers 80 adapted to be shifted between projected positions as shown in Fig. 13 and retracted positions as shown in Fig. 14; (2) compression coil springs 90 serving as biasing means for biasing the third plungers 80 toward the retracted positions; and (3) communication paths 100 for allowing third cylinders 36c which accommodates the third plungers 80 to communicate with the second cylinders 36b.

The sectional area of the second plunger 50 is smaller than that of the first plunger 40, and the sectional area of the third plunger 36c is smaller than that of the second plunger 36b. This allows the oil from the first cylinders 36a to be distributed to both the second cylinders 36b and the third cylinders 36c.

In this embodiment, compression coil springs 110, 120 and 130 are respectively provided for biasing the

first, second and third plungers 40, 50 and 80 toward the projected positions. The compression coil springs 110, 120 and 130 respectively allow the first plungers 40, the second plungers 50 and the third plungers 80 to be pushed back to original positions when the roll shaft is not driven. More specifically, when the compression coil springs 110 urge the first plungers 40 and thereby the oil flows back to the first cylinders 36a, the forces applied by the compression coil springs 70 and 90 are balanced with forces applied by the compression coil springs 120 and 130, respectively, so that the second plungers 50 and the third plungers 80 are pushed back to the original positions.

In accordance with this embodiment, the third plungers 80 projected to the projected positions push the flat surfaces 22A of the roll shaft 21 toward the first plungers 40 when the phase shift occurs as shown in Fig. 14. Therefore, the roll shaft 21 can be firmly coupled to the coupling 3, thereby assuredly preventing the vibration and unstableness of the roll shaft 21. When the roll shaft is not driven, the third plungers 80 are pushed back to the retracted positions by the compression coil springs 90.

It should be understood that the present invention is not limited to the aforesaid embodiments. Where the roll shaft is adapted to rotate in one direction, for example, either ones of the shaft coupling mechanisms P or Q may be employed depending on the rotational direction. Various modifications may be made without departing from the spirit and scope of the present invention.

Claims

1. A shaft coupling mechanism comprising
 - a rotary shaft (21) and a rotary cylinder (3b) which are engaged with each other for transmission of a torque in a state where a predetermined phase shift therebetween is permitted,
 - the rotary shaft (21) and the rotary cylinder (3b) having a first clearance therebetween which is adapted to be reduced according to a phase shift and a second clearance therebetween which is always constant regardless of the phase shift, and
 - a hydraulic mechanism (36a, 40, 60, 36b, 50, 36c, 80, 100) for transforming a force applied as fluid pressure for reducing the first clearance into a force for retaining the rotary shaft (21) in the second clearance.
2. A shaft coupling mechanism as set forth in claim 1, wherein
 - the rotary shaft (21) has an outer peripheral surface including a pair of flat surfaces (22A) disposed opposite to each other, and a pair of curved surfaces (22B) disposed opposite to each other,
 - the rotary cylinder (3b) has an inner peripheral surface including a pair of first opposed surfaces (38A) respectively facing opposite to the pair of flat surfaces (22A) with a space including the first

clearance interposed therebetween, and a pair of second opposed surfaces (38B) respectively facing opposite to the pair of the curved surfaces (22B) with the second clearance interposed therebetween, and

the hydraulic mechanism comprises:

first plungers (40) respectively accommodated in first cylinders (36a) provided in association with the first opposed surfaces (38A), which are adapted to approach the flat surfaces (22A) when a phase shift occurs and to shift between projected positions and retracted positions where the first plungers are pushed for retraction by the corresponding flat surfaces when the phase shift occurs;

second plungers (50) respectively accommodated in second cylinders (36b) provided in association with the second opposed surfaces (38B), which are adapted to shift between projected positions where the second plungers (50) can press the corresponding curved surfaces (22B) and retracted positions where the second plungers (50) are spaced apart from the corresponding curved surfaces (22B);

communication paths (60) for allowing the first cylinders (36a) to communicate with the corresponding second cylinders (36b) to form closed fluid lines; and

biasing means (70) for biasing the second plungers (50) toward the retracted positions.

3. A shaft coupling mechanism as set forth in claim 2, wherein

the hydraulic mechanism further comprises:

third plungers (80) respectively accommodated in third cylinders (36c) provided in association with the first opposed surfaces (38A) which are spaced apart from the flat surfaces (22A) when the phase shift occurs, the third plungers (80) are shifted between projected positions where the third plungers (80) press the flat surfaces (22A) and retracted positions where the third plungers (80) are spaced apart from the flat surfaces (22A);

biasing means (90) for biasing the third plungers (80) toward the retracted positions; and

communication paths (100) for allowing the third cylinders (36c) to communicate with at least either ones of the first cylinders (36a) or the second cylinders (36b).

4. A shaft coupling mechanism as set forth in claim 2 or 3, wherein

the second cylinders (36b) each have a smaller sectional area than the first cylinders (36a).

5. A shaft coupling mechanism as set forth in any one of claims 2 to 4, wherein

each of the first opposed surfaces (38A) is formed with a recess (38c) for increasing the phase

shift between the rotary shaft (21) and the rotary cylinder (3b).

FIG. 1

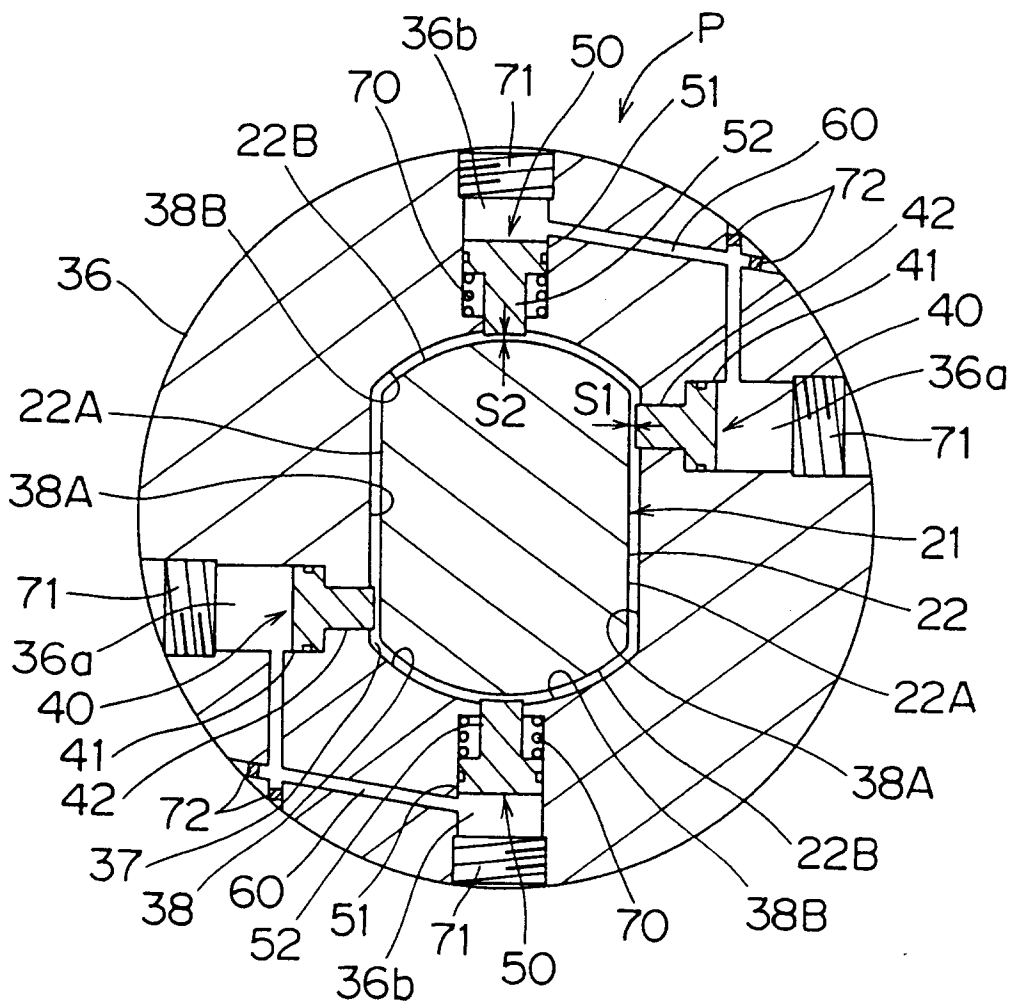

FIG. 2

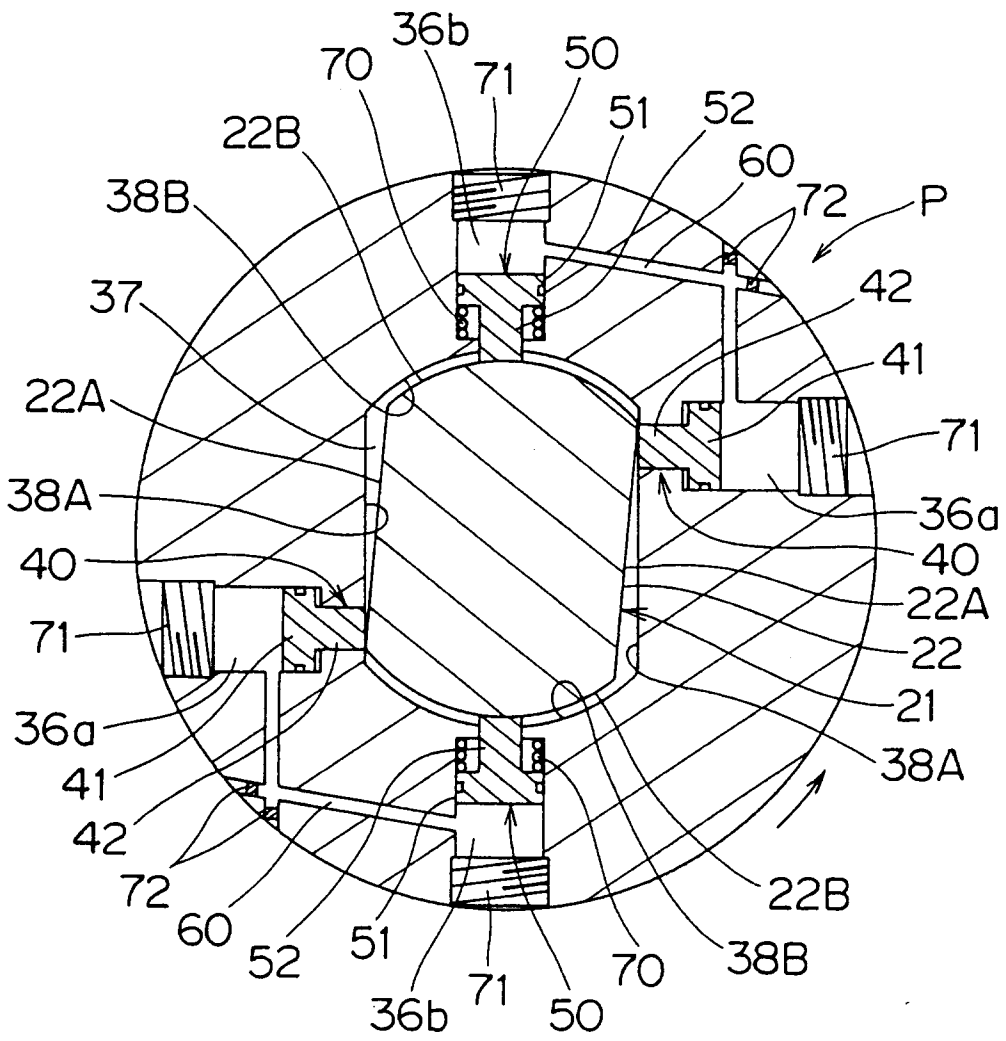

FIG. 3

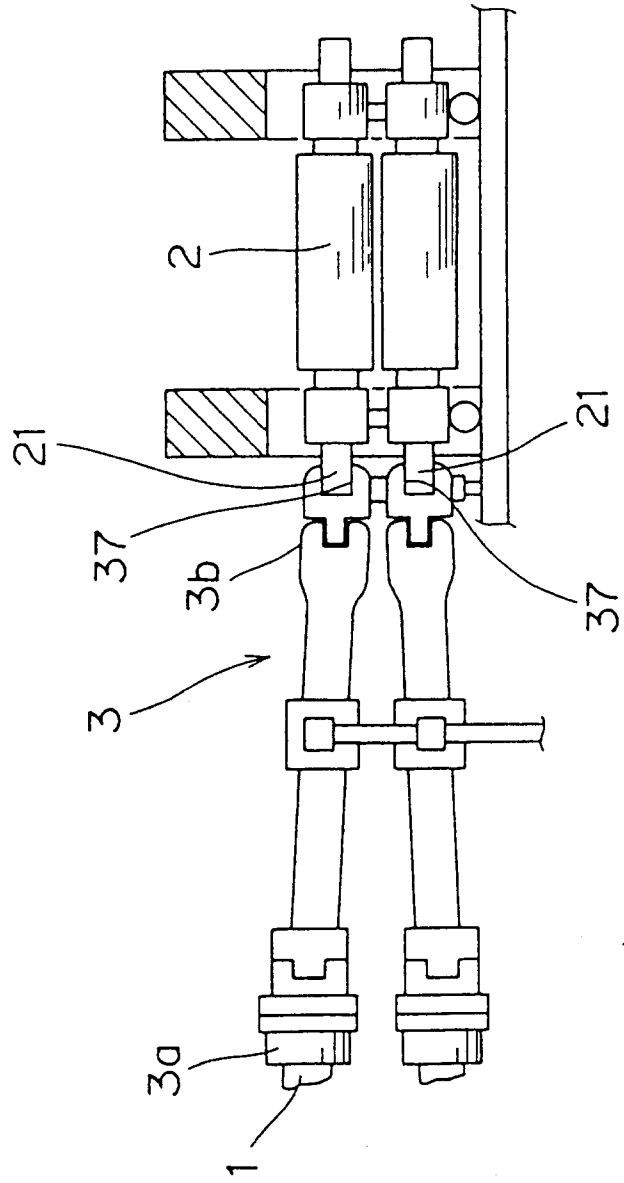

FIG. 4

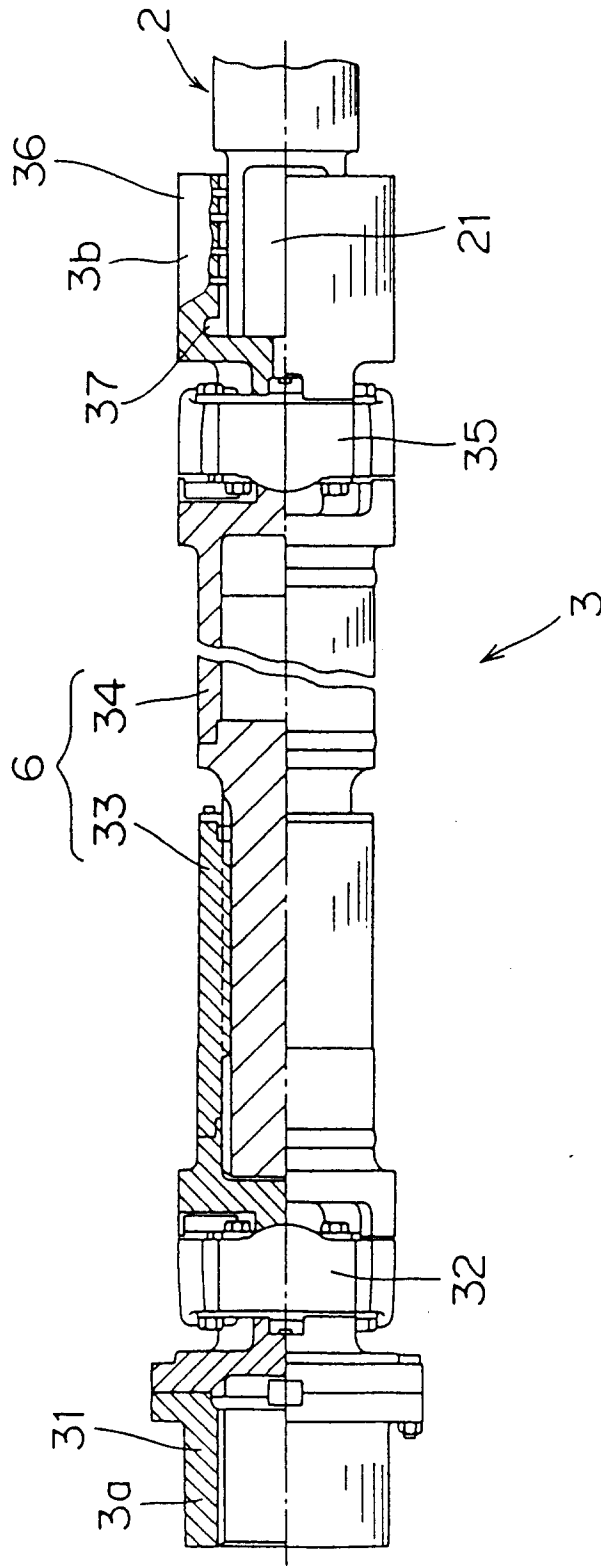

FIG. 5

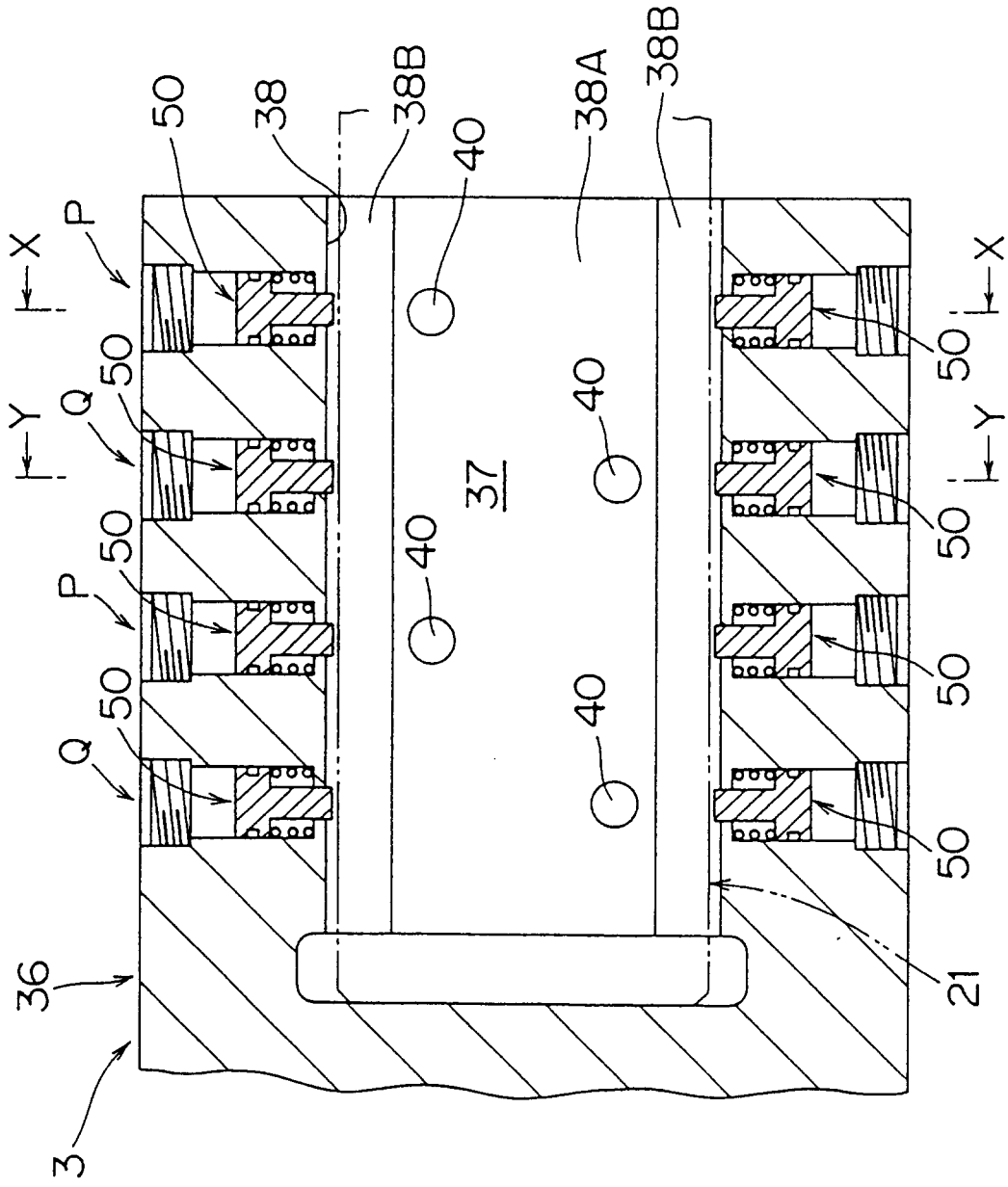

FIG. 6

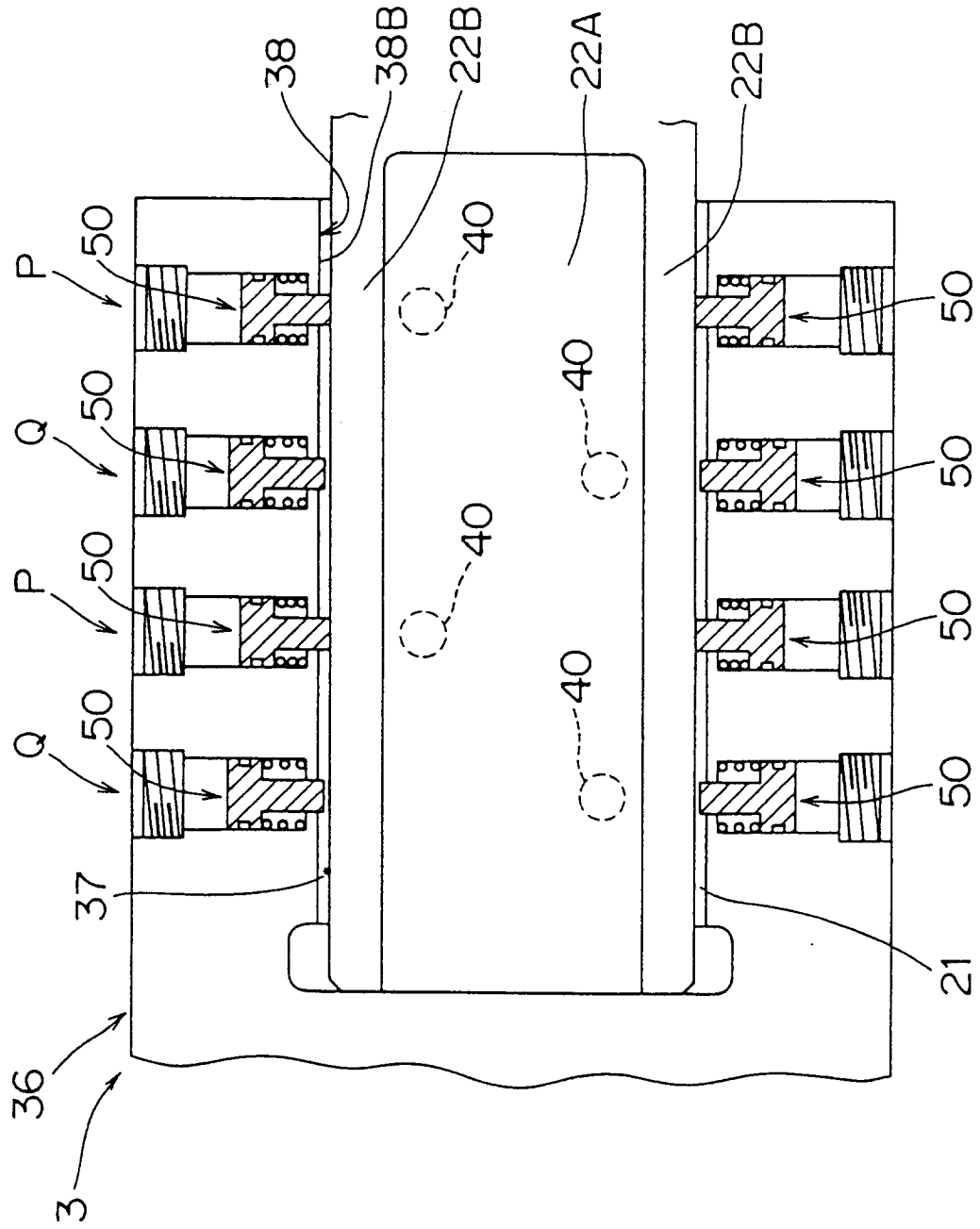

FIG. 7

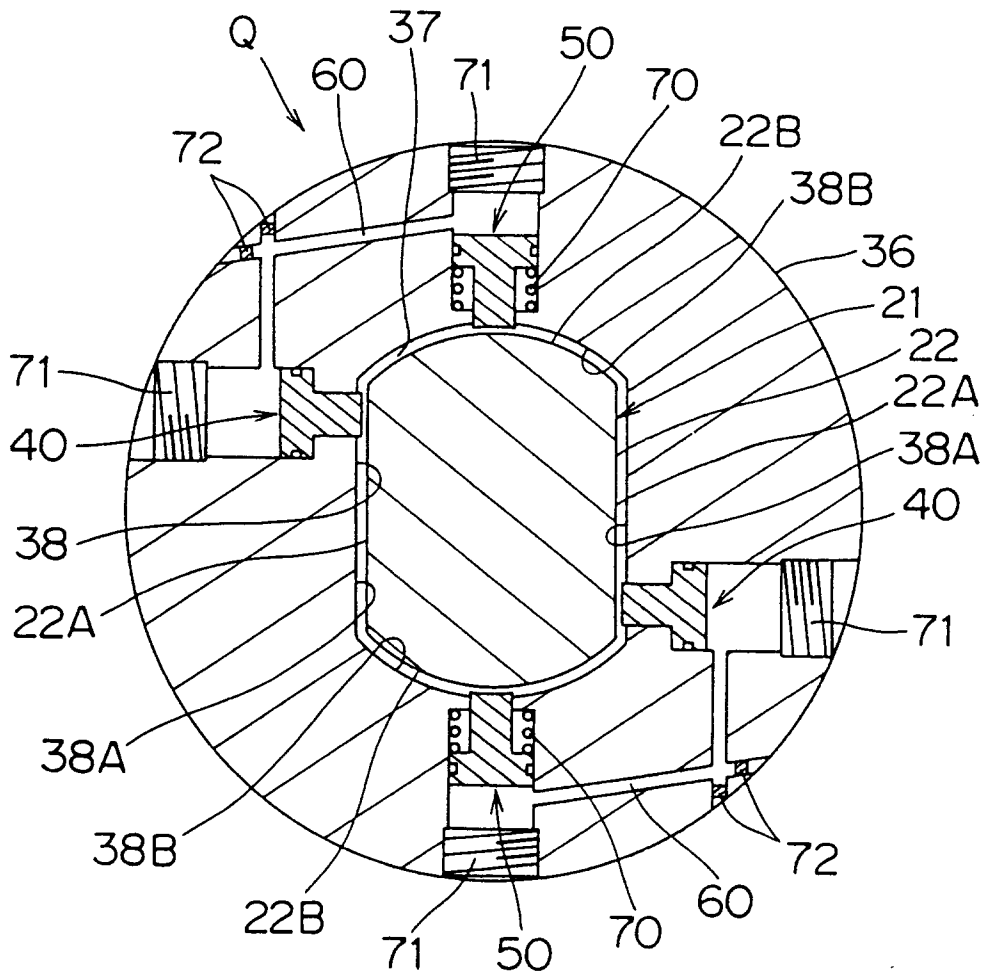

FIG. 8

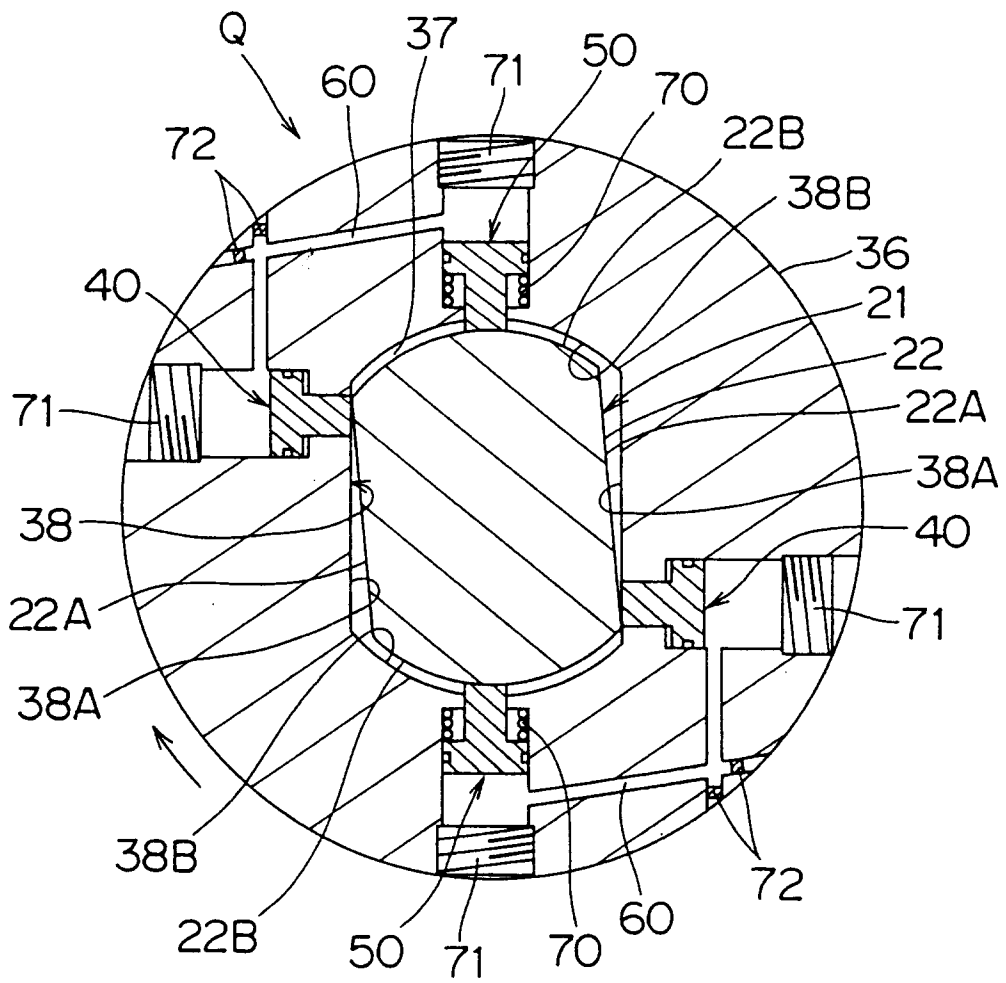

FIG. 9

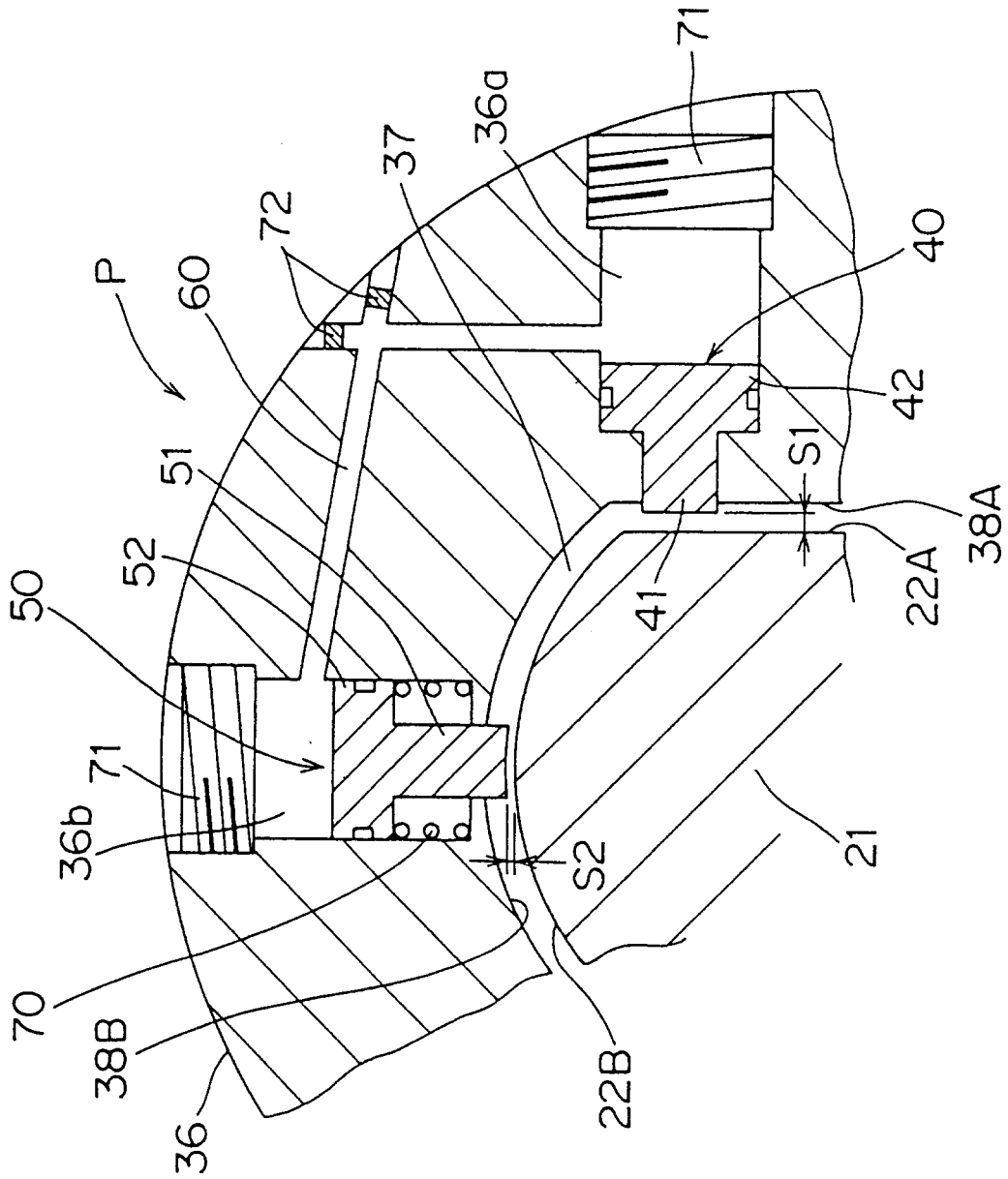

FIG. 10

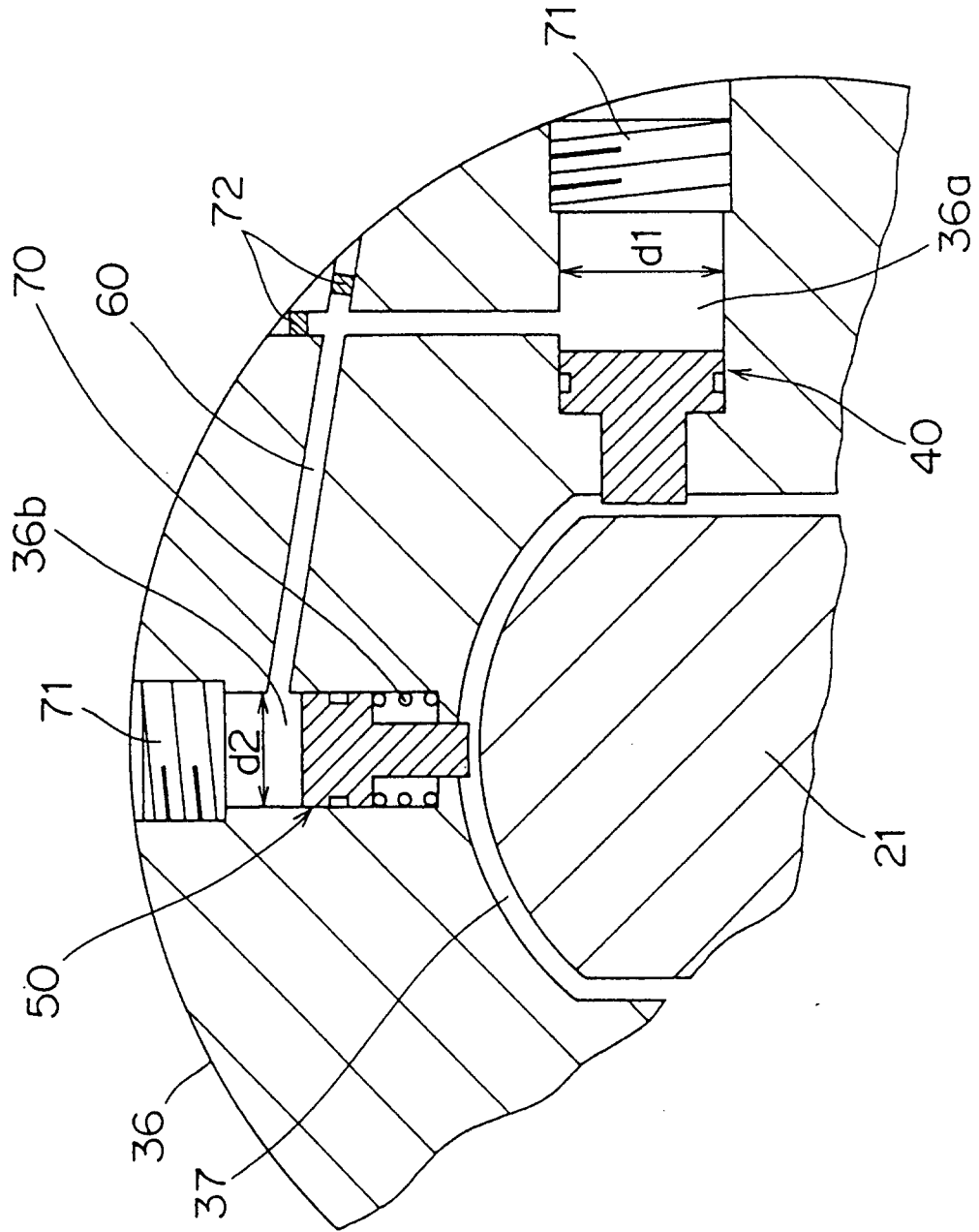

FIG. 11

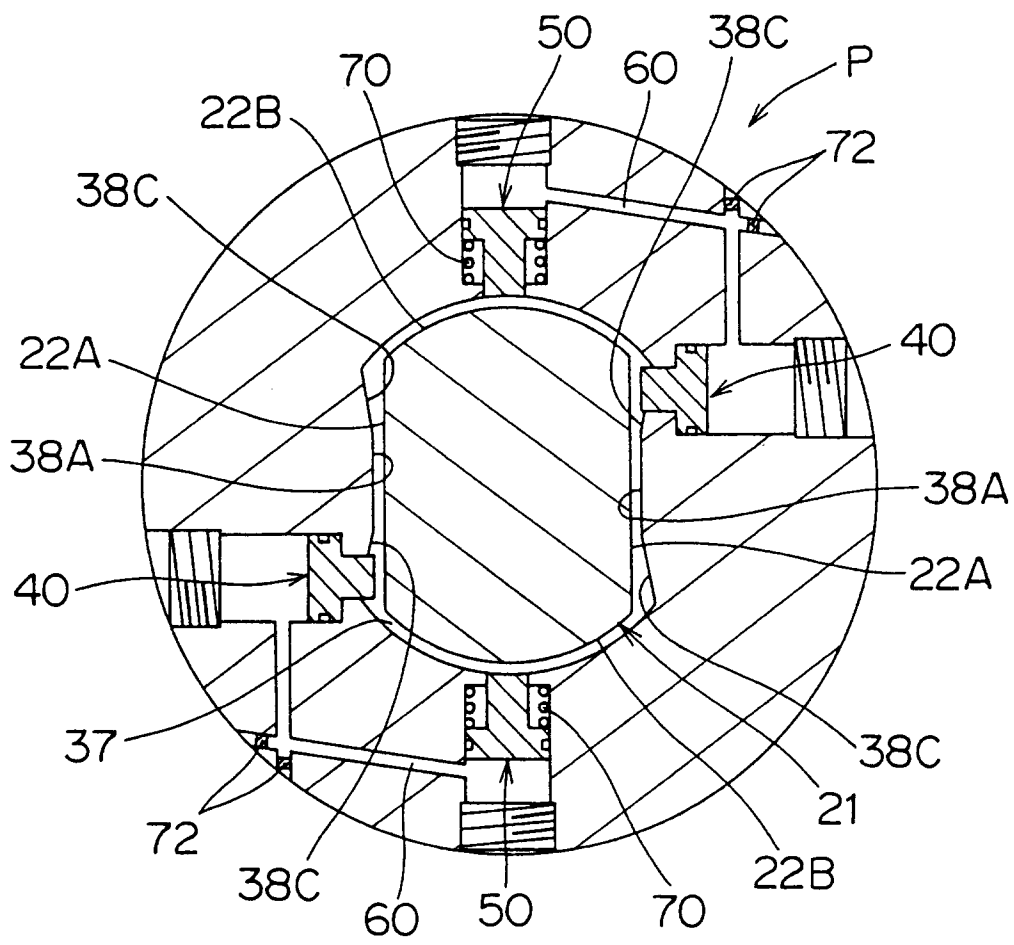

FIG. 12

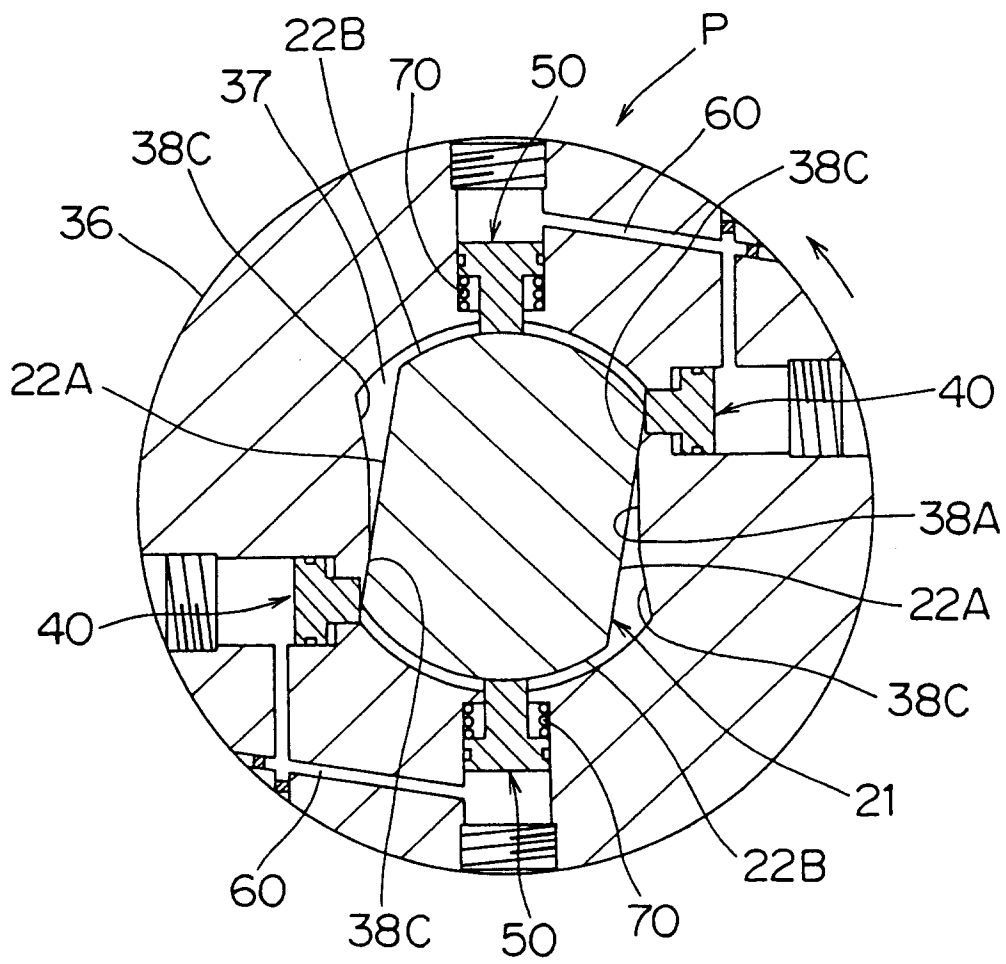

FIG. 13

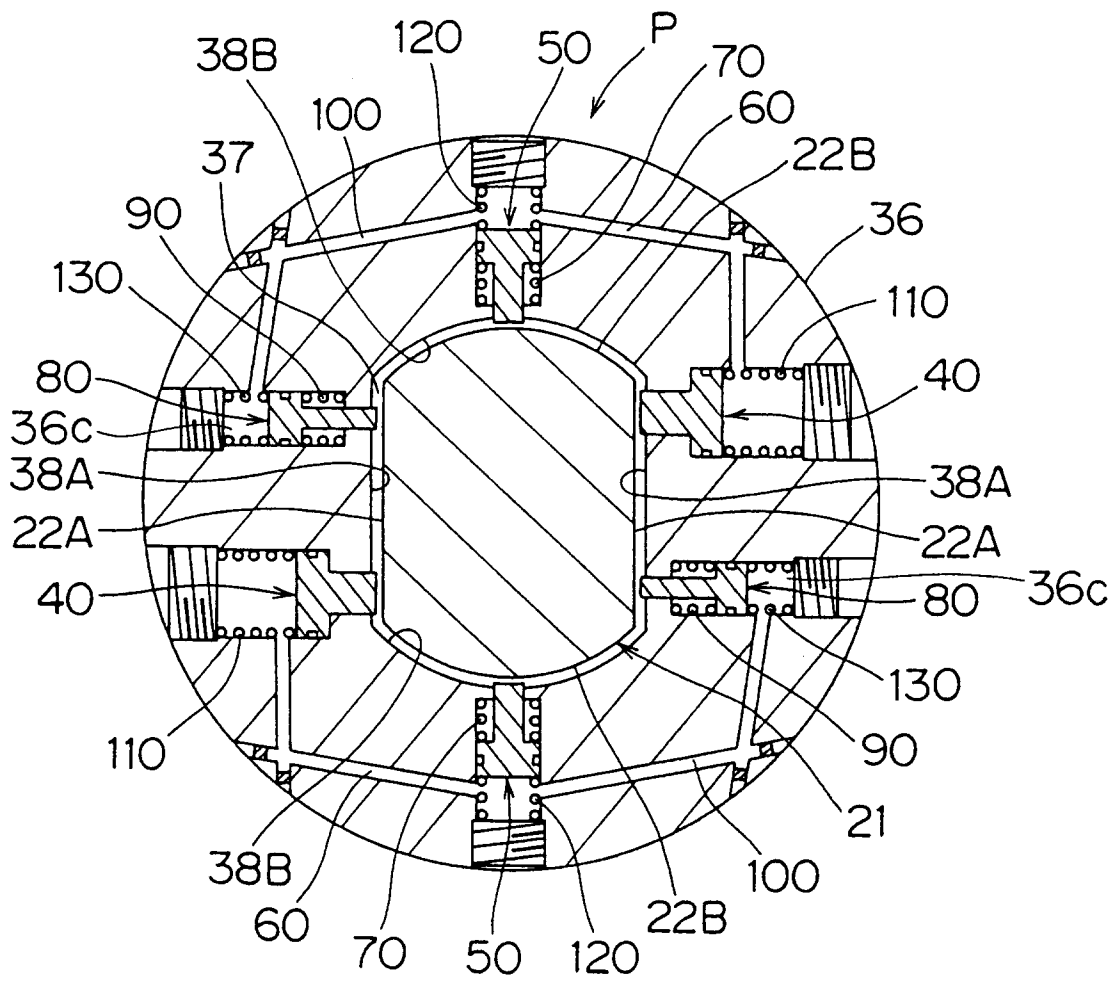
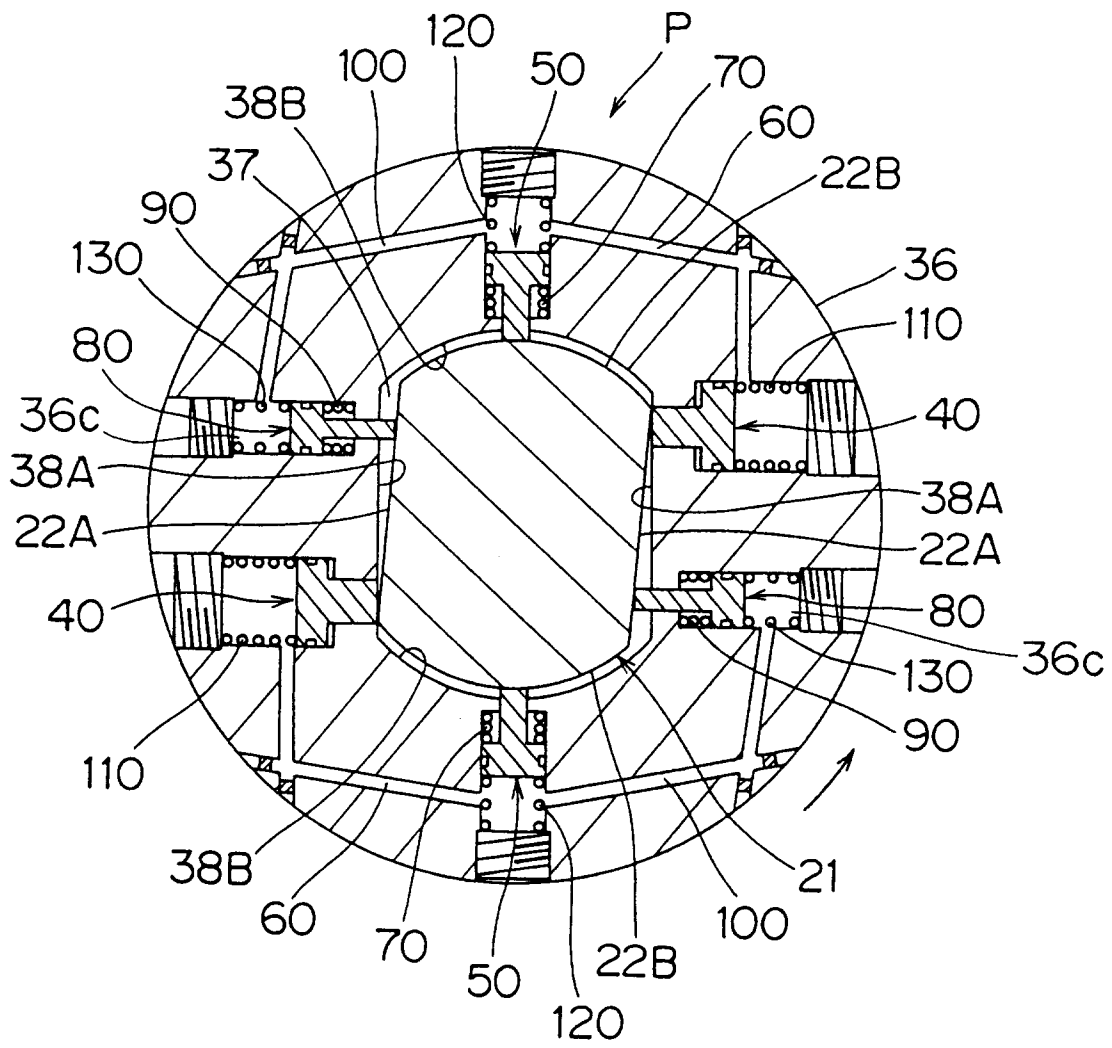

FIG. 14





European Patent Office

EUROPEAN SEARCH REPORT

Application Number
EP 96 10 2538

DOCUMENTS CONSIDERED TO BE RELEVANT			
Category	Citation of document with indication, where appropriate, of relevant passages	Relevant to claim	CLASSIFICATION OF THE APPLICATION (Int.Cl.6)
A	US-A-3 626 719 (CHURCH ROBERT M) 14 December 1971 * the whole document *	1,2,5	B21B35/14
A	--- PATENT ABSTRACTS OF JAPAN vol. 017, no. 198 (M-1398), 19 April 1993 & JP-A-04 344811 (ISHIKAWAJIMA HARIMA HEAVY IND CO LTD), 1 December 1992, * abstract *	1,2	
D,A	--- PATENT ABSTRACTS OF JAPAN vol. 018, no. 444 (M-1658), 18 August 1994 & JP-A-06 137338 (NAKAMURA JIKOU:KK), 17 May 1994, * abstract *	1	
			TECHNICAL FIELDS SEARCHED (Int.Cl.6)
			B21B F16D
The present search report has been drawn up for all claims			
Place of search		Date of completion of the search	Examiner
THE HAGUE		31 May 1996	Rosenbaum, H
CATEGORY OF CITED DOCUMENTS			
X : particularly relevant if taken alone Y : particularly relevant if combined with another document of the same category A : technological background O : non-written disclosure P : intermediate document		T : theory or principle underlying the invention E : earlier patent document, but published on, or after the filing date D : document cited in the application L : document cited for other reasons & : member of the same patent family, corresponding document	

EPO FORM 1503 03.82 (P/ACD)