

(19)



Europäisches Patentamt

European Patent Office

Office européen des brevets



(11)

EP 0 730 554 B1

(12)

EUROPEAN PATENT SPECIFICATION

(45) Date of publication and mention
of the grant of the patent:

21.10.1998 Bulletin 1998/43

(21) Application number: **95905902.3**

(22) Date of filing: **14.12.1994**

(51) Int. Cl.⁶: **B65D 71/00**

(86) International application number:
PCT/US94/14285

(87) International publication number:
WO 95/16617 (22.06.1995 Gazette 1995/26)

(54) **BOTTLE CARRIER**

FLASCHERTRÄGER

SYSTEME DE TRANSPORT POUR BOUTEILLES

(84) Designated Contracting States:

AT BE CH DE DK ES FR GB GR IE IT LI NL PT SE

(30) Priority: **14.12.1993 GB 9325497**

(43) Date of publication of application:

11.09.1996 Bulletin 1996/37

(73) Proprietor: **THE MEAD CORPORATION**

Dayton Ohio 45463 (US)

(72) Inventor: **BAKX, Martinus**

NL-4461 LS Goes (NL)

(74) Representative:

Hepworth, John Malcolm et al

Hepworth Lawrence Bryer & Bizley

Bloxam Court

Corporation Street

Rugby, Warwickshire CV21 2DU (GB)

(56) References cited:

EP-A- 0 134 694

EP-A- 0 170 259

AU-A- 453 888

AU-D- 4 449 172

CH-A- 441 112

DE-A- 3 206 522

US-A- 4 372 599

EP 0 730 554 B1

Note: Within nine months from the publication of the mention of the grant of the European patent, any person may give notice to the European Patent Office of opposition to the European patent granted. Notice of opposition shall be filed in a written reasoned statement. It shall not be deemed to have been filed until the opposition fee has been paid. (Art. 99(1) European Patent Convention).

Description

The invention relates to carriers for articles such as bottles. More particularly, the invention relates to carriers which grip the tops of bottles for example.

It is known to provide carriers of the top gripping type which comprise a series of interconnected panels including top, bottom and side panels, and article receiving apertures in the top and bottom panel which receive the neck of a bottle. In order to retain the bottle in the receiving apertures, it is known to provide so-called sub burst features around the periphery of an aperture such that when a bottle is passed through the aperture the plurality of tabs which form the sub burst engage the underside of a bottle cap or protruding flange for example. A top gripping carrier of this type is disclosed in GB 2154197B.

Another type of top gripping carrier is disclosed in EP 42720B1 wherein a triangular formation is shown having top and bottom apertures such that the load of a bottle is transmitted through the triangular side walls adjacent the aperture into the base panel thereby to provide relatively rigid article gripping device.

EP-A-170 259 (Unilever) discloses a top gripping carton for two rows of articles gripped by a foldable cardboard sleeve. The sleeve has an upper wall, a lower wall and an intermediate section for stiffening. Tabs folded from one panel are pressed against a second wall, and can be clipped under the rim of each bottle neck. The crown closures are exposed above the upper walls.

US 3 640 563 (Wood) discloses a top gripping carrier formed in an elongate tubular structure and including opposed top and bottom walls and a pair of upwardly conveying support panels disposed within the tubular structure and being secured to respective side walls. The carrier includes a plurality of aligned apertures formed in the top and bottom panels and in the support walls.

There are several problems with known carriers including for example that they expose the bottle cap and that part of the neck label directly beneath the cap which is often damaged and unsightly.

The invention sees to avoid or at least mitigate these and other problems of the prior art. Advantageously, the unsightly damaged label can be screened from the view of a customer purchasing the packaged articles. Additionally, a strong article retaining means can be provided within the carrier.

One aspect of the invention provides an article carrier for packaging at least one necked article, comprising opposed top and bottom walls hingably interconnected by a pair of opposed side walls to form a tubular structure, the top wall being adapted to be disposed over the top of a necked article, the bottom wall having at least one neck-receiving aperture for receiving the neck of the article, the side walls being adapted to be disposed alongside the neck of the article, and

retaining means for retaining the top of the article between the top and bottom walls of the carrier, the retaining means comprising a first retention panel hingably connected to one of the side walls at an intermediate position between the top and bottom walls to engage the top of the article, characterised in that said retaining means further comprises a first support panel for holding said first retention panel inclined to said top wall such that said first retention panel extends upwardly and inwardly of said tubular structure from said one side wall, said first support panel extending between said top wall and the upper inner end of said first retention panel to interconnect said top wall and said first retention panel.

Preferably, the distance between said top wall and said intermediate position may be greater than the length of said first support panel extending between said top wall and said first retention panel whereby said first retention panel is held inclined to said top wall.

According to an optional feature of this aspect of the invention, the carrier may further comprise end closure means for at least partially closing open ends of said tubular structure, said end closure means being struck from said bottom wall to define said at least one neck-receiving aperture and being hingably joined to said bottom wall.

According to another optional feature of this aspect of the invention, said one side wall may have at said intermediate position a glue tab secured thereto, said first retention panel being hingably connected to said one side wall through said glue tab.

According to a further optional feature of this aspect of the invention, said retaining means may further comprise a second retention panel hingably connected to the other of said side walls at an intermediate position between said top and bottom walls to engage the top of said article, and a second support panel for holding said second retention panel inclined to said top wall such that said second retention panel extends upwardly and inwardly of said tubular structure from said other side wall, said second support panel extending between said top wall and the upper inner end of said second retention panel to interconnect said top wall and said second retention panel.

Preferably, said first and second support panels may be secured together in a face to face contacting relationship to form a centre support means disposed generally vertically between said side walls.

According to another optional feature of this aspect of the invention, said top wall may comprise a pair of first and second panel portions, said first panel portion extending between and hingably joined to said one side wall and the upper end of said first support panel, said second panel portion extending between and hingably joined to said other side wall and the upper end of said second support panel.

According to still a further optional feature of this aspect of the invention, said first and second retention

panels in cooperation may define at least one top-receiving aperture for receiving the top of said article so that first and second retention panels are engaged at the aperture rims thereof with the top of said article.

Another aspect of the invention provides a blank for forming a carrier according to the other aspect of the invention.

The blank can comprise a series of hingably interconnected panel portions including longitudinally end-most securing tab, an intermediate panel for forming article retaining means, a central support panel, an upper panel portions, side panel, and base panel portion which panels are repeated about a transverse symmetry axis through one of said panels.

Another aspect of the invention provides use of a blank according to another aspect of the invention to form a carrier of packaged articles.

Another aspect of the invention provides in an article carrier for packaging necked articles, for example, bottles, article release means comprising a first retention panel hingably connected to a first side wall and a second retention panel hingably connected to a second side wall wherein the first and second retention panels are hingably connected along a common fold line and wherein the article release means comprises a bottle top receiving and retaining aperture such that the top of the associated article is retained by said retention panel characterised in that each said first and second retention panels comprises an edge of said retaining aperture to retain top portion of said article and in that said first retention panel and said second retention panel is adapted to be downwardly flexed to increase the distance between said aperture edges to release said article. Preferably, said side panel may be flexed outwardly to enable removal of an article from the carrier.

An embodiment of the invention will now be described, by way of example only, with reference to the accompanying drawings, in which:-

FIGURE 1 is a plan view of a blank for forming a carton according to the invention;

FIGURE 2 is an end elevation view of a carton according to the invention showing the article loading process with end closure 40 removed for clarity;

FIGURE 3 is an end elevation view of the carton shown in Figure 2 with an article loaded;

FIGURE 3a is a sectional plan view along line X-X of the carton shown in Figure 3; and

FIGURE 4 is an end elevation view of the carton shown in Figures 2 and 3 during removal of an article.

Referring to Figure 1 there is shown a carton blank 10 in a particular form of the invention which is adapted to produce a carton for carrying three necked articles such as bottles. In this particular example, blank 10 is symmetrical about a central transverse fold line 23. The blank comprises at one end a glue tab 12, hinged to an intermediate retention panel 14. The retention panel 14 is hinged to a central support panel 16 along fold line 15 which is interrupted by three article top receiving apertures 36 struck from panels 14 and 16. Central support panel 16 is hinged to top wall panel portion 18 which in turn is hinged to side panel 20. Panel 20 is hinged to base panel portion 22 which in turn is hinged to a second base panel portion 24 along interrupted fold line 23. Due to the reflective symmetry about fold line 23, carton blank 10 therefore comprises side panel 26, upper panel portion 28, central support panel 30, intermediate retention panel 32 and a further glue tab 34.

The base of the carton comprising panels 22 and 24 comprise article neck receiving apertures 38 which interrupt the central fold line 23. In this embodiment, the two endmost apertures 38 have struck therein end closures 40. The end closures 40 are hinged to the base panels 22 and 24 along fold lines 54 and comprise two main panel portions 42 and 44 hingably connected along that part of fold line 23 which extends into the end closures 40. The main panels 42 and 44 comprise lateral tabs 48 and 52 hingably connected to but partially cut from the main end closure panels by cuts 46 and 50 respectively.

The end elevation view shown in Figure 2 shows a carton 11 constructed from blank 10 in which all the carton panels are clearly indicated. It is evident therefore that glue tabs 12 and 34 are adhered to the inside faces of side panels 20 and 26 respectively. The positioning of the glue tabs is such as to bring central support panels 16 and 30 together so that they can be adhered to one another as shown in Figure 2. In this way, the carton is formed having an upper wall comprising panels 18 and 28, side walls comprising side panel 20 and 26, and a base wall comprising panels 22 and 24. Additionally, the carton 11 comprises article retaining means 60 intermediate the top and bottom walls.

The article retaining means comprises retention panels 14 and 32, and central support panels 16 and 30 which are formed within the carton to provide apertures to receive article tops and retain each article in the carton until it is removed for use. Thus, an aperture is created by two associated apertures 36 from panels 14 and 32 as can be seen from Figure 3a. Means 60 is connected to the top wall of the carrier 11 along fold lines 17 and 29 and to the side walls 20 and 26 along fold lines 13 and 33. In this example the fold lines 13 and 33 are disposed such that side wall panel portions 20a and 26a are taller than panels 16 and 30 which due to the relative size of the other panels causes panels 14 and 32 to be inclined to the horizontal in the packaged position shown in Figure 3.

Referring now the operation of loading carton 11 with a bottle B as shown in Figures 2 and 3, it can be seen that carton 11 in its initial position has its top panels 18 and 28 inclined to the horizontal by an angle which is less than that of the intermediate retention panels 14 and 32. A bottle top C is passed through an aperture 38 with little resistance but in order for the cap C to pass through the aperture in intermediate retention panels 14 and 32, the rim 37 of the aperture 36 needs to flex outwardly and only minimal resistance to this movement is presented provided that the carton 11 is made of a blank of suitable resilient material such as medium calliper paperboard, for example. Having passed the carton 11 onto the top of a bottle B as shown in Figure 3 the carton 11 is positioned so that the top panels 18 and 28 are substantially horizontal or parallel with the top cap of the bottle, and substantially parallel to base panels 22 and 24. Since the base wall is wider than the top wall of the carton 11, the side walls 20 and 26 are inclined to the vertical so as to contour the neck of the bottle. However, the configuration of the internal bottle retaining means 60 is such that intermediate retention panels 14 and 32 are inclined at an angle relative to the planes of the top and bottom panels of the packaged carton. As can be seen from Figure 2, side panel portions 20a and 26a are larger than central support panels 30 and 16 respectively.

In order to remove a bottle B from the carton 11, it is necessary for the bottle caps C to pass back through the associated part of the aperture 36 in the intermediate retention panels 14 and 32. However, the underside of the bottle cap C engages the intermediate retention panels 14 and 32 adjacent the aperture rim 37 thereby restraining further movement of the bottle relative to the carton 11 as can be seen from Figure 3a. As the relative movement continues the bottle cap C forces the intermediate panels 14 and 32 into an alignment substantially parallel to the base panel 22 and 24 as seen in Figure 4. However, as can be seen in Figure 4, this movement causes the upper panels 18 and 28 to be drawn downwardly against the natural resistance of the carton structure. Accordingly, a resistive force is presented against the withdrawal of the bottle from the carton 11. This resistance is of course quite different from the action provided when loading the carton due to the relative sizes and configuration of various panels as described earlier. Accordingly a greatly increased force is required to remove the bottle from the carton compared to the force required to load the bottles into the carton. It is thereby found that a suitable carton retaining means can be provided so that for example, the three bottles contained within a carton 11 can be carried without significant risk of a bottle becoming accidentally detached from the carton. Naturally, it would also be possible to provide a handle on the carton.

It is apparent therefore that the carton provides the various advantages of enabling good bottle retention in a carton whilst providing a carton which also hides from

view that part of the bottle label L adjacent the bottle cap C which can be unsightly from a marketing or aesthetic point of view or which may, for example be furnished with a single product bar code. Further, a carton made from paperboard or similar material can of course carry printed matter such as product designation or advertising material thereby enhancing the point of sale presentation of the product.

As well as obscuring from view from the sides of the carrier that part of the label L which might be torn, the carton can also comprise end closures 40 which as shown schematically in Figure 3 act to obscure the majority of the end view of the bottle neck retained in the carton 11 and particularly that part of the label L directly below the bottle cap C. These end closures 40 can be put into position simply by passing a bottle through the associated aperture 38 and by causing the end closure 40 to pivot about hinge line 54. The end closure 40 is then raised to an upright position wherein friction tabs 48 and 52 fold about hinges at opposite ends of cuts 50 and 46 thereby to retain the end closure 40 in its upright position. Advantageously, the end closure 40 can be contoured at its upper end 56 so as to marry the shape of the underside of intermediate panels 14 and 32 in the formed carton 11. This enables complete screening of the end beneath the intermediate panels 14 and 32 and above the bottom walls 22 and 24 and also enables a further resistance against movement of the intermediate panels 14 and 32 when trying to withdraw a bottle B from carton 11.

Claims

1. An article carrier for packaging at least one necked article, comprising opposed top and bottom walls (18, 28; 22, 24) hingably interconnected by a pair of opposed side walls (20, 26) to form a tubular structure, the top wall (18, 28) being adapted to be disposed over the top of a necked article, the bottom wall (22, 24) having at least one neck-receiving aperture (38) for receiving the neck of the article, the side walls (20, 26) being adapted to be disposed alongside the neck of the article, and retaining means (60) for retaining the top (C) of the article between the top and bottom walls (18, 28; 22, 24) of the carrier, the retaining means (60) comprising a first retention panel (14) hingably connected to one of the side walls (20) at an intermediate position between the top and bottom walls (18, 22) to engage the top (C) of the article, characterised in that said retaining means (60) further comprises a first support panel (16) for holding said first retention panel (14) inclined to said top wall (18) such that said first retention panel (14) extends upwardly and inwardly of said tubular structure from said one side wall (20), said first support panel (16) extending between said top wall (18) and the upper inner end of said first retention panel (14) to interconnect

- said top wall (18) and said first retention panel (14).
2. The carrier according to claim 1 wherein the distance between said top wall and said intermediate position is greater than the length of said first support panel (16) extending between said top wall (18) and said first retention panel (14) whereby said first retention panel (14) is held inclined to said top wall (18).
 3. The carrier according to claim 1 or claim 2, further comprising end closure means (40) for at least partially closing open ends of said tubular structure, said end closure means (40) being struck from said bottom wall (22, 24) to define said at least one neck-receiving aperture (38) and being hingably joined to said bottom wall (22, 24).
 4. The carrier according to any preceding claim wherein said one side wall (20) has at said intermediate position a glue tab (12) secured thereto, said first retention panel (14) being hingably connected to said one side wall (20) through said glue tab (12).
 5. The carrier according to any preceding claim wherein said retaining means (60) further comprises a second retention panel (32) hingably connected to the other of said side walls (26) at an intermediate position between said top and bottom walls (28, 24) to engage the top of said article, and a second support panel (30) for holding said second retention panel (32) inclined to said top wall (28) such that said second retention panel (32) extends upwardly and inwardly of said tubular structure from said other side wall (26), said second support panel (30) extending between said top wall (28) and the upper inner end of said second retention panel (32) to interconnect said top wall (28) and said second retention panel (32).
 6. The carrier according to claim 5 wherein said first and second support panels (14, 32) are secured together in a face to face contacting relationship to form a centre support means disposed generally vertically between said side walls (20, 26).
 7. The carrier according to claim 5 or claim 6 wherein said top wall comprises a pair of first and second panel portions (18, 28), said first panel portion (18) extending between and hingably joined to said one side wall (20) and the upper end of said first support panel (16), said second panel portion (28) extending between and hingably joined to said other side wall (26) and the upper end of said second support panel (30).
 8. The carrier according to any of claims 5 to 7 wherein said first and second retention panels (14, 32) in cooperation define at least one top-receiving aperture (36) for receiving the top of said article so that first and second retention panels (14, 32) are engaged at the aperture rims thereof with the top of said article.
 9. A blank for forming a carrier according to any of the preceding claims.
 10. A blank according to claim 9 comprising a series of hingably interconnected panel portions including longitudinally endmost securing tab (40), an intermediate retention panel (14) for forming article retaining means, a central support panel (16), an upper panel portions (20a), side panel (20), and base panel portion (22) which panels are repeated about a transverse symmetry axis through one of said panels.
 11. Use of a blank according to claim 9 or 10 to form a carrier of packaged articles.
 12. In an article carrier for packaging necked articles, for example, bottles, article release means comprising a first retention panel (14) hingably connected to a first side wall (20) and a second retention panel (32) hingably connected to a second side wall (26) wherein the first and second retention panels (14, 32) are hingably connected along a common fold line and wherein the article release means comprises a bottle top receiving and retaining aperture (36) such that the top of the associated article is retained by said first and second retention panels (14, 32), characterised in that said first and second retention panels (14, 32) each comprise an edge of said retaining aperture (36) to retain top portion of said article and in that said first retention panel (14) and said second retention panel (32) is adapted to be downwardly flexed to increase the distance between said aperture edges to release said article.
 13. A carrier according to claim 12 wherein said side panels (20, 32) are flexed outwardly to enable removal of an article from the carrier.

Patentansprüche

1. Gegenstandsträger zum Verpacken wenigstens eines einen Hals aufweisenden Gegenstands, wobei der Träger gegenüberliegende Decken- und Bodenwände (18, 28; 22, 24) aufweist, die gelenkig miteinander durch ein Paar gegenüberliegender Seitenwände (20, 26) verbunden sind, um eine röhrenförmige Struktur auszubilden, wobei die Deckenwand (18, 28) angepaßt ist, um über dem Oberteil eines einen Hals aufweisenden Gegenstands angeordnet zu werden, wobei die Boden-

- wand (22, 24) wenigstens eine Hals-aufnehmende Öffnung (38) aufweist, um den Hals eines Gegenstands aufzunehmen, wobei die Seitenwände (20, 26) angepaßt sind, um längsseits des Halses des Gegenstands angeordnet zu werden, ferner Rückhalte-
mittel (60) zum Zurückhalten des Oberteils (C) des Gegenstands zwischen den Decken- und Bodenwänden (18, 28; 22, 24) des Trägers, wobei die Rückhalte-
mittel (60) eine erste Rückhalte-Wandfläche (14) umfassen, die gelenkig mit einer der Seitenwände (20) an einer Stelle verbunden sind, die zwischen den Decken- und Bodenwänden (18, 22) angeordnet ist, um das Oberteil (C) des Gegenstands in Eingriff zu nehmen, dadurch gekennzeichnet, daß die Rückhalte-
mittel (60) weiterhin eine erste Stützwandfläche (16) umfassen, um die erste Rückhalte-Wandfläche (14) abge-
schrägt zu der Deckenwand (18) zu halten, dergestalt, daß die erste Rückhalte-Wandfläche (14) sich nach unten hin und in das Innere der röhrenförmigen Struktur von einer Seitenwand (20) erstreckt, wobei die erste Stützwandfläche (16) sich zwischen der Deckenwand (18) und dem oberen inneren Ende der ersten Rückhalte-Wandfläche 14 erstreckt, um die Deckenwand (18) und die erste Rückhalte-Wandfläche (14) zu verbinden.
2. Gegenstandsträger nach Anspruch 1, in welchem der Abstand zwischen der Deckenwand und der Zwischen-Stelle größer ist als die Länge der ersten Stützwandfläche (16), die sich zwischen der Deckenwand (18) und der ersten Rückhalte-Wandfläche (14) erstreckt, wodurch die erste Rückhalte-Wandfläche (14) schräg verlaufend zu der Deckenwand gehalten wird.
3. Gegenstandsträger nach Anspruch 1 oder 2, der weiterhin Endverschlußmittel (40) zum wenigstens teilweisen Verschließen der offenen Enden der röhrenförmigen Struktur umfaßt, wobei die Endverschlußmittel (40) aus der Bodenwand (22, 24) gestanzt sind, um wenigstens eine Hals-aufnehmende Öffnung (38) zu definieren und gelenkig mit der Bodenwand (22, 24) verbunden sind.
4. Gegenstandsträger gemäß einem der vorhergehenden Ansprüche, in welchem eine Seitenwand (20) an der Zwischen-Stelle eine hieran befestigte Klebelasche (12) aufweist, wobei die erste Rückhalte-Wandfläche (14) gelenkig mit der einen Seitenwand (20) durch die Klebelasche (12) verbunden ist.
5. Gegenstandsträger gemäß einem der vorhergehenden Ansprüche, in welchem die Rückhalte-
mittel (60) weiterhin eine zweite Rückhalte-Wandfläche (32) umfassen, die gelenkig mit der anderen der Seitenwände (26) an der Zwischen-Stelle zwischen der Decken- und der Bodenwand (28, 24) verbunden ist, um das Oberteil des Gegenstands in Eingriff zu nehmen, sowie eine zweite Stützwandfläche (30), um die zweite Rückhalte-Wandfläche 32 abge-
schrägt zu der Deckenwand 28 zu halten, dergestalt, daß die zweite Rückhalte-Wandfläche (32) sich nach unten hin und in das Innere der röhrenförmigen Struktur von der anderen der Seitenwände (26) erstreckt, wobei die zweite Stützwandfläche (30) sich zwischen der Deckenwand (28) und dem oberen inneren Ende der zweiten Rückhalte-Wandfläche (32) erstreckt, um die Deckenwand (28) und die zweite Rückhalte-Wandfläche (32) zu verbinden.
6. Gegenstandsträger nach Anspruch 5, in welchem die erste und zweite Stützwandfläche (14, 32) miteinander in einer flächenberührenden Beziehung verbunden sind, um eine mittlere Unter-
stützungseinrichtung bereitzustellen, die im wesentlichen senkrecht zwischen den Seitenwänden (20, 26) angeordnet ist.
7. Gegenstandsträger nach Anspruch 5 oder 6, in welchem die Deckenwand ein Paar erster und zweiter Wandflächenabschnitte (18, 28) umfaßt, wobei der erste Wandflächenabschnitt (18) sich zwischen einer Seitenwand (20) und dem oberen Ende der ersten Stützwandfläche (16) erstreckt und gelenkig mit der ersten Seitenwand (20) und dem oberen Ende der ersten Stützwandfläche (16) verbunden ist, wobei der zweite Wandflächenabschnitt (28) sich zwischen der anderen Seitenwand (26) und dem oberen Ende der zweiten Stützwandfläche (30) erstreckt und gelenkig mit der anderen Seitenwand (26) und dem oberen Ende der zweiten Stützwandfläche (30) verbunden ist.
8. Gegenstandsträger gemäß einem der Ansprüche 5 bis 7, in welchem die erste und zweite Stützwandfläche (14, 32) in zusammenwirkender Weise wenigstens eine Oberteil-aufnehmende Öffnung (36) zum Aufnehmen des Oberteils des Gegenstands definieren, dergestalt, daß die erste und zweite Rückhalte-Wandfläche (14, 32) an ihren Öffnungs-Auskragungen in Eingriff mit dem Oberteil des Gegenstands genommen werden.
9. Zuschnitt zur Ausbildung eines Gegenstandsträgers gemäß einem der vorhergehenden Ansprüche.
10. Zuschnitt gemäß Anspruch 9, der eine Reihe gelenkig miteinander verbundener Wandflächenabschnitte umfaßt, die eine längs verlaufende, äußerste Sicherungsglasche (40) einschließen, eine mittlere Rückhalte-Wandfläche (14) zum Ausbilden von Gegenstands-Rückhalte-
mittel, eine mittlere

Stützwandfläche (16), einen oberen Wandflächenabschnitt (20a), eine Seitenwand (20), und einen Grundwandflächenabschnitt (22), wobei die Wandflächen sich über eine quer verlaufende Symmetrieachse durch eine der Wandflächen wiederholen. 5

11. Verwendung eines Zuschnitts gemäß der Ansprüche 9 oder 10, um einen Gegenstandsträger für verpackte Gegenstände auszubilden. 10
12. Gegenstands-Freigabemittel in einem Gegenstandsträger für die Verpackung Hals-aufweisender Gegenstände, beispielsweise Flaschen, wobei die Gegenstands-Freigabemittel eine erste Rückhalte-Wandfläche (14) umfassen, die gelenkig mit einer ersten Seitenwand (20) verbunden ist, sowie eine zweite Rückhalte-Wandfläche (32), die gelenkig mit einer zweiten Seitenwand (26) verbunden ist, wobei die erste und die zweite Rückhalte-Wandfläche (14, 32) gelenkig entlang einer gemeinsamen Faltlinie verbunden sind und wobei die Gegenstands-Freigabemittel eine Flaschenoberteil-aufnehmende und zurückhaltende Öffnung (36) umfassen, dergestalt, daß das Oberteil des dazugehörigen Gegenstands durch die erste und zweite Rückhalte-Wandfläche (14, 32) zurückgehalten wird, dadurch gekennzeichnet, daß die erste und zweite Rückhalte-Wandfläche (14, 32) jeweils eine Kante der Rückhalteöffnung (36) umfassen, um den Deckenabschnitt des Gegenstands zurückzuhalten und dadurch, daß die erste Rückhalte-Wandfläche (14) und die zweite Rückhalte-Wandfläche (32) angepaßt sind, nach unten hin gebogen zu werden, um den Abstand zwischen den Öffnungskanten zu vergrößern, um den Gegenstand freizugeben. 20 25 30 35
13. Gegenstandsträger gemäß Anspruch 12, in welchem Seitenwandflächen (20, 32) nach außen hin gebogen werden, um das Entfernen eines Gegenstandes aus dem Gegenstandsträger zu ermöglichen. 40

Revendications

1. Système de transport d'article pour l'emballage d'au moins un article pourvu d'un goulot, comportant des parois supérieure et inférieure opposées (18, 28; 22, 24) reliées de manière articulée par une paire de parois latérales opposées (20, 26) afin de former une structure tubulaire, la paroi supérieure (18, 28) étant prévue pour être disposée sur le dessus d'un article pourvu d'un goulot, la paroi inférieure (22, 24) ayant au moins une ouverture de réception de goulot (38) destinée à recevoir le goulot de l'article, les parois latérales (20, 26) étant prévues pour être disposées le long du goulot de l'article, et des moyens de retenue (60) destinés à maintenir le dessus (C) de l'article entre les parois 45 50 55

supérieure et inférieure (18, 28; 22, 24) du système de transport, les moyens de retenue (60) comportant un premier panneau de retenue (14) relié de manière articulée à l'une des parois latérales (20) dans une position intermédiaire entre les parois supérieure et inférieure (18, 22) afin d'engager le dessus (C) de l'article, caractérisé en ce que lesdits moyens de retenue (60) comportent, en outre, un premier panneau de support (16) destiné à maintenir ledit premier panneau de retenue (14) incliné par rapport à ladite paroi supérieure (18) de telle sorte que ledit premier panneau de retenue (14) s'étende vers le haut et vers l'intérieur de ladite structure tubulaire depuis ladite première paroi latérale (20), ledit premier panneau de support (16) s'étendant entre ladite paroi supérieure (18) et l'extrémité interne supérieure dudit premier panneau de retenue (14) afin de relier ensemble ladite paroi supérieure (18) et ledit premier panneau de retenue (14).

2. Système de transport selon la revendication 1, dans lequel la distance entre ladite paroi supérieure et ladite position intermédiaire est plus grande que la longueur dudit premier panneau de support (16) s'étendant entre ladite paroi supérieure (18) et ledit premier panneau de retenue (14) de sorte que ledit premier panneau de retenue (14) est maintenu incliné par rapport à ladite paroi supérieure (18).
3. Système de transport selon la revendication 1 ou la revendication 2, comportant, en outre, des moyens de fermeture d'extrémité (40) afin de fermer au moins partiellement des extrémités ouvertes de ladite structure tubulaire, lesdits moyens de fermeture d'extrémité (40) étant tirés depuis dans ladite paroi inférieure (22, 24) afin de définir ladite au moins une ouverture de réception de goulot (38) et étant reliés de manière articulée à ladite paroi inférieure (22, 24).
4. Système de transport selon l'une quelconque des revendications précédentes, dans lequel ladite première paroi latérale (20) a dans ladite position intermédiaire une patte de collage (12) fixée dessus, ledit premier panneau de retenue (14) étant relié de manière articulée à ladite première paroi latérale (20) par ladite patte de collage (12).
5. Système de transport selon l'une quelconque des revendications précédentes, dans lequel lesdits moyens de retenue (60) comportent, en outre, un deuxième panneau de retenue (32) relié de manière articulée à l'autre desdites parois latérales (26) dans une position intermédiaire entre lesdites parois supérieure et inférieure (28, 24) afin d'engager le dessus dudit article, et un deuxième panneau

- de support (30) destiné à maintenir ledit deuxième panneau de retenue (32) incliné par rapport à ladite paroi supérieure (28) de telle sorte que ledit deuxième panneau de retenue (32) s'étende vers le haut et vers l'intérieur de ladite structure tubulaire depuis ladite autre paroi latérale (26), ledit deuxième panneau de support (30) s'étendant entre ladite paroi supérieure (28) et l'extrémité interne supérieure dudit deuxième panneau de retenue (32) afin de relier ladite paroi supérieure (28) et ledit deuxième panneau de retenue (32).
6. Système de transport selon la revendication 5, dans lequel lesdits premier et deuxième panneaux de support (14, 32) sont fixés ensemble en relation de contact face à face afin de former des moyens de support central disposés globalement verticalement entre lesdites parois latérales (20, 26).
7. Système de transport selon la revendication 5 ou la revendication 6, dans lequel ladite paroi supérieure comporte une paire de première et deuxième parties de panneau (18, 28), ladite première partie de panneau (18) s'étendant entre et étant reliée de manière articulée à ladite première paroi latérale (20) et à l'extrémité supérieure dudit premier panneau de support (16), ladite deuxième partie de panneau (28) s'étendant entre et étant reliée de manière articulée à ladite autre paroi latérale (26) et l'extrémité supérieure dudit deuxième panneau de support (30).
8. Système de transport selon l'une quelconque des revendications 5 à 7, dans lequel lesdits premier et deuxième panneaux de retenue (14, 32) définissent en coopération au moins une ouverture de réception de dessus (36) destinée à recevoir le dessus dudit article de sorte que lesdits premier et deuxième panneaux de retenue (14, 32) sont engagés au niveau des rebords d'ouverture de ceux-ci avec le dessus dudit article.
9. Flan destiné à former un système de transport selon l'une quelconques des revendications précédentes.
10. Flan selon la revendication 9, comportant une série de parties de panneau reliées de manière articulée comprenant une patte de fixation longitudinalement la plus en bout (40), un panneau de retenue intermédiaire (14) destiné à former des moyens de retenue d'article, un panneau de support central (16), des parties de panneau supérieur (20a), un panneau latéral (20), et une partie de panneau de base (22), lesquels panneaux sont répétés autour d'un axe transversal de symétrie à travers l'un desdits panneaux.
11. Utilisation d'un flan selon la revendication 9 ou 10 afin de former un système de transport d'articles emballés.
12. Dans un système de transport d'article pour l'emballage d'articles pourvus d'un goulot, par exemple des bouteilles, des moyens de libération d'article comportant un premier panneau de retenue (14) relié de manière articulée à une première paroi latérale (20) et un deuxième panneau de retenue (32) relié de manière articulée à une deuxième paroi latérale (26), dans lequel les premier et deuxième panneaux de retenue (14, 32) sont reliés de manière articulée le long d'une ligne de pliage commune et dans lequel les moyens de libération d'article comportent une ouverture de réception et de retenue de dessus de bouteille (36) de telle sorte que le dessus de l'article associé est retenu par lesdits premier et deuxième panneaux de retenue (14, 32), caractérisés en ce que lesdits premier et deuxième panneaux de retenue (14, 32) comportent chacun un bord de ladite ouverture de retenue (36) afin de retenir la partie supérieure dudit article et en ce que ledit premier panneau de retenue (14) et ledit deuxième panneau de retenue (32) sont prévus pour être fléchis vers le bas afin d'augmenter la distance entre lesdits bords d'ouverture de façon à libérer ledit article.
13. Système de transport selon la revendication 12, dans lequel lesdits panneaux latéraux (20, 32) sont fléchis vers l'extérieur afin de permettre le retrait d'un article du système de transport.

FIG. 1.

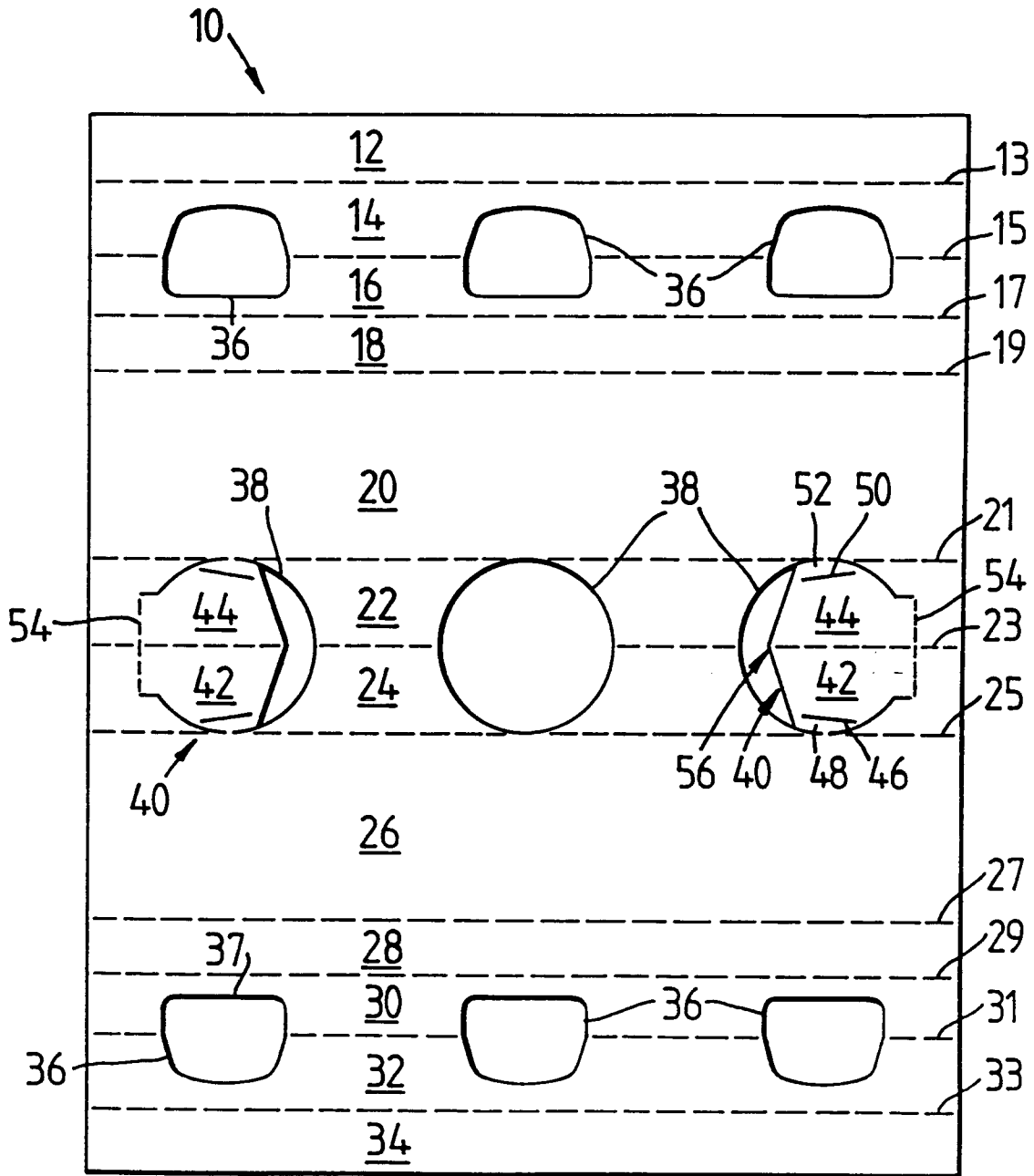
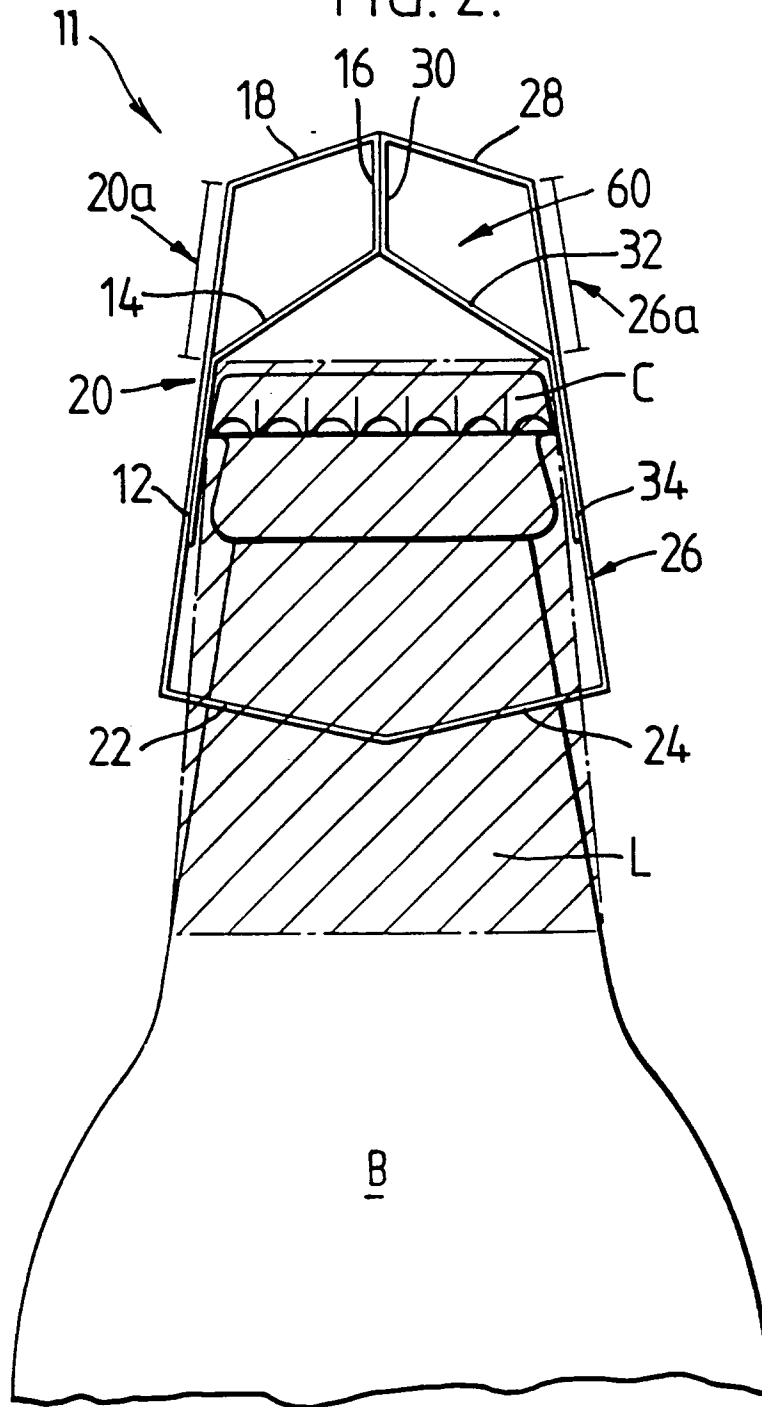

FIG. 2.



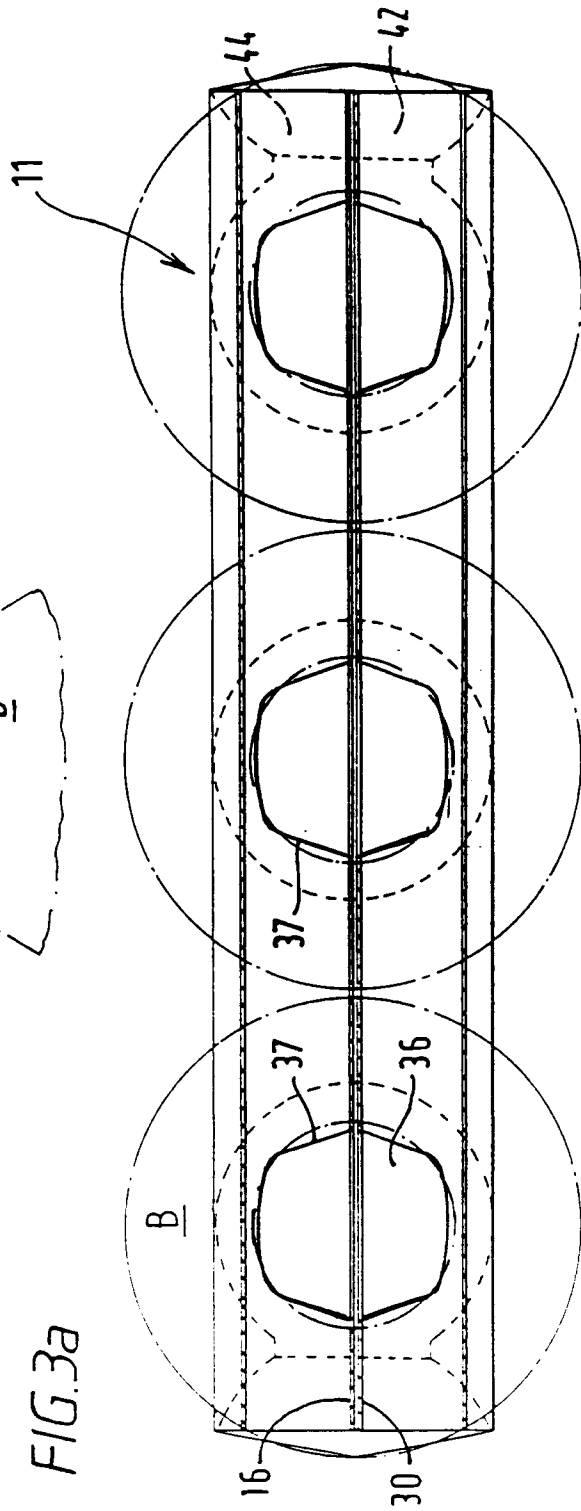
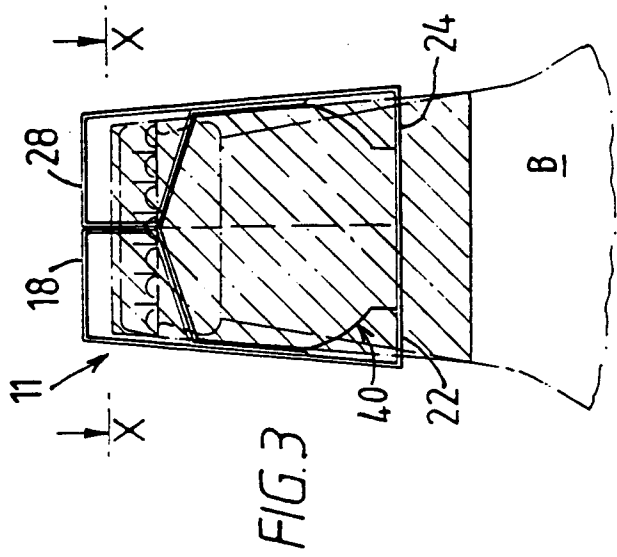

FIG. 4.

