

(19)



Europäisches Patentamt

European Patent Office

Office européen des brevets



(11)

**EP 0 736 738 B1**

(12)

**EUROPEAN PATENT SPECIFICATION**

(45) Date of publication and mention  
of the grant of the patent:

**08.09.1999 Bulletin 1999/36**

(51) Int Cl.6: **F25C 1/08**

(21) Application number: **96110325.6**

(22) Date of filing: **29.03.1993**

(54) **Ice making machine**

Eiserzeugungsmaschine

Machine génératrice de glace

(84) Designated Contracting States:  
**DE ES FR GB IT**

(30) Priority: **31.07.1992 JP 5965292 U**  
**22.08.1992 JP 6440092 U**

(43) Date of publication of application:  
**09.10.1996 Bulletin 1996/41**

(62) Document number(s) of the earlier application(s) in  
accordance with Art. 76 EPC:  
**93105187.4 / 0 580 950**

(73) Proprietor: **HOSHIZAKI DENKI KABUSHIKI**  
**KAISHA**  
**Toyoake-shi, Aichi-ken (JP)**

(72) Inventors:

- **Sakai, Tadashi, c/o Hoshizaki Denki K.K.**  
**Sakae-machi, Toyoake, Aichi (JP)**
- **Sanuki, Masao, c/o Hoshizaki Denki K.K.**  
**Sakae-machi, Toyoake, Aichi (JP)**

(74) Representative: **Prüfer, Lutz H., Dipl.-Phys. et al**  
**PRÜFER & PARTNER,**  
**Patentanwälte,**  
**Harthausen Strasse 25d**  
**81545 München (DE)**

(56) References cited:

**AU-A- 2 273 077**                      **FR-A- 2 038 067**  
**FR-A- 2 522 123**                      **GB-A- 2 090 955**  
**US-A- 2 718 125**                      **US-A- 3 418 823**  
**US-A- 5 187 948**

**EP 0 736 738 B1**

Note: Within nine months from the publication of the mention of the grant of the European patent, any person may give notice to the European Patent Office of opposition to the European patent granted. Notice of opposition shall be filed in a written reasoned statement. It shall not be deemed to have been filed until the opposition fee has been paid. (Art. 99(1) European Patent Convention).

## Description

### BACKGROUND OF THE INVENTION

**[0001]** The present invention relates to an ice making machine.

**[0002]** More particularly, this invention relates to a cam control mechanism in an ice making machine, in which a multiplicity of freezing fingers formed on the lower surface of a freezing base plate are dipped in the water supplied to a freezing chamber defined in a water tray to carry out a freezing operation and form inverted dome-shaped ice pieces gradually around the freezing fingers. The cam control mechanism of the invention successfully carries out a series of cam actions to be caused in accordance with the rotation of an actuator motor for driving the water tray:

- (1) tilting of the water tray and resetting thereof to the horizontal posture;
- (2) supply of hot gas to an evaporator for accelerating releasing of ice pieces in the ice releasing operation and stopping thereof; and
- (3) replenishment of water to be frozen after a cycle of freezing operation and stopping thereof, whereby to realize simplification of the control system and reduction of production cost.

**[0003]** Various types of freezing systems have been proposed for automatic ice making machines for making a number of ice pieces such as cubes continuously, and they are suitably employed depending on the applications. For example, the following systems are known:

- (1) a so-called closed cell system ice making machine having a multiplicity of freezing cells opening downward defined by a multiplicity of partitions crossing one another, to which water is injected upward to the respective freezing cells, which are cooled by an evaporator connected to a freezing system, from a water tray disposed below the freezing cells to form ice cubes gradually therein;
- (2) a so-called open cell system ice making machine having such freezing cells opening downward, in which water is sprayed upward directly into the freezing cells using no water tray to form ice cubes therein; and
- (3) a flow-down system ice making machine having a perpendicular freezing plate, in which water is supplied to flow down on one surface of the freezing plate to form a semicylindrical ice block on the corresponding surface.

**[0004]** These three types of ice making machines all employ a forced circulation system and have a water tank for carrying therein a predetermined amount of water to be frozen, and the water in the tank is fed by a pump to the freezing cells or to the perpendicular freez-

ing plate disposed in a freezing unit, while the unfrozen portion of the water is recovered into the tank to recirculate it to the freezing unit. Accordingly, incidental equipments such as a water tank and a pump for circulating the water to be frozen become necessary in such types of ice making machines. This causes not only complication of the structure of the machine but also production cost elevation and enlargement of the machine. Meanwhile, there has already been proposed a more simplified ice making machine, in which freezing fingers extending downward from the lower surface of a freezing base plate provided with an evaporator thereon are dipped in a predetermined level of water carried in a water tray to form ice pieces around the freezing fingers. This type of ice making machine requires no mechanism for circulating the water to be frozen between the water tray and the water tank during the freezing operation, so that the structure of the machine can be simplified, leading to production cost reduction and down-sizing of the machine, advantageously.

**[0005]** As described above, the last mentioned ice making machine, in which ice pieces are designed to be formed around the freezing fingers merely by dipping them in the water carried in the water tray, enjoys a great advantage that the structure of the machine can be simplified. However, the control system of the machine is not necessarily simplified actually. Namely, in the ice making machine, the freezing cycle and the ice releasing cycle are repeated alternatively, and water to be frozen must be replenished whenever the freezing cycle is started. Meanwhile, after completion of the freezing cycle, a hot gas must be supplied to the evaporator after the water tray is tilted and stopped at a predetermined angle so as to accelerate dropping of the ice pieces formed around the freezing fingers by their own weights. It is also necessary to stop supply of the hot gas to the evaporator and supply a cooling medium instead thereto after dropping of the ice pieces, as well as, to allow the water tray stopping in the tilted posture to reset to the horizontal posture and resume the freezing operation. Accordingly, various types of sensors and a complicated control circuit become necessary in order to control such series of actions, contributing less to the overall production cost, disadvantageously, in spite of the simplified mechanical structure.

**[0006]** From GB 2 090 955 A an ice making machine according to the preamble of claim 1 is known. The control cam acts on a limit micro switch which controls the operation of a geared motor. The geared motor rotates a shaft which is connected with the water tray. A spring clutch is provided between the output rod of the geared motor and the shaft.

**[0007]** It is the object of the present invention to provide an ice making machine with a cam control mechanism which can successfully attain a series of cam actions to be caused in accordance with rotation of the actuator motor for driving the water tray, wherein in particular the speed of operation can be increased.

**[0008]** This object is solved by an ice making machine as set forth in claim 1.

**[0009]** Preferred developments of the ice making machine are given in the dependent claims.

**[0010]** The mechanisms of the ice making machine as set forth in the appended claims are proposed in order to overcome the above problems and attain the intended objects successfully. According to the mechanism in the ice making machine of this invention, in which a multiplicity of freezing fingers formed on the lower surface of a freezing base plate are dipped in the water carried in the freezing chamber defined in a water tray to carry out a freezing operation and form inverted dome-shaped ice pieces gradually around the freezing fingers, the following motions:

- (1) tilting of the water tray and resetting thereof to the horizontal posture;
- (2) supply of hot gas to an evaporator for accelerating releasing of ice pieces in the ice releasing operation and stopping thereof; and
- (3) replenishment of water to be frozen after a cycle of freezing operation and stopping thereof are designed to be carried out by a series of cam actions to be caused in accordance with the rotation of an actuator motor for driving the water tray, whereby to realize simplification of the control system and reduction of production cost.

**[0011]** In the cam control mechanism in the ice making machine according to this invention, in which a multiplicity of freezing fingers formed on the lower surface of a freezing base plate are dipped in the water to be frozen carried in the freezing chamber defined in the water tray, the tilting of the water tray and resetting thereof to the horizontal posture, as well as stopping thereof at such postures in an ice making machine are successfully achieved by a series of cam actions to be caused in accordance with the rotation of the actuator motor which is a driving source for a water tray tilting mechanism. Meanwhile, in addition to the tilting and resetting of the water tray, as well as, stopping thereof at such postures, supply of a hot gas to the evaporator for accelerating dropping of ice pieces in the ice releasing operation and stopping thereof and also replenishment of water to be frozen after a freezing operation and stopping thereof are also designed to be controlled by a series of cam actions in accordance with the rotation of the actuator motor. Accordingly, the constitution of the control system in the ice making machine can notably be simplified to contribute greatly as a whole to the reduction of production cost. Moreover, since a plurality of cam surfaces are formed on one cam plate so as to control tilting and resetting of the water tray, as well as, stopping thereof at such postures by the switches disposed correspondingly to the respective cam surfaces, not only the number of parts can be reduced, but also the control system can be simplified.

**[0012]** Meanwhile, since the water tray is adapted to be pivotally supported at the pintles formed integrally therewith onto the main body of the ice making machine, the water tray can smoothly be tilted and reset on the pintle. Namely, since the load of the water tray is applied evenly to the pintles, no bias load is applied to the pivotal shaft and connection rod connected to the pintles to allow smooth pivoting of the water tray.

**[0013]** Moreover, since the pivotal shaft for tilting the water tray is pivotally supported onto the main body of the ice making machine, heat insulation at such portions can be facilitated, advantageously. Further, the drain pipe disposed to the water tray is allowed to serve also as a stopper for retaining the water tray in a tilted posture, so that there is no need of providing a stopper additionally, and the number of parts can be reduced, leading to cost reduction.

#### BRIEF DESCRIPTION OF THE DRAWINGS

**[0014]** Fig. 1 shows schematically in perspective view a cam control mechanism in an ice making machine according to a first embodiment of the invention.

**[0015]** Fig. 2 shows a diagram of control circuit connected to the cam control mechanism.

**[0016]** Fig. 3 shows a timing chart for the control to be effected by the cam control mechanism.

**[0017]** Fig. 4 shows schematically in exploded perspective view a freezing unit in which the cam control mechanism is employed.

**[0018]** Fig. 5 shows in vertical section the major portion of the freezing unit shown in Fig. 4.

**[0019]** Fig. 6 shows in partially cut-away perspective view the water tray shown in Fig. 4, as well as, the rocking plate to be incorporated therein and a drainage for discharging the water to be frozen.

**[0020]** Fig. 7 shows schematically in vertical section the ice making machine in which the cam control mechanism is employed.

**[0021]** Fig. 8 shows in partially cut-away perspective view the ice making machine shown in Fig. 7.

**[0022]** Fig. 9 shows schematically a freezing system to be employed in the ice making machine.

**[0023]** Fig. 10 shows in vertical section the major portion of the freezing unit shown in Fig. 5, where the rocking plate is ascended during the freezing operation.

**[0024]** Fig. 11 shows in vertical section the major portion of the freezing unit shown in Fig. 5, where the rocking plate is descended in the freezing operation.

**[0025]** Fig. 12 shows in vertical section the freezing unit, where ice formation is completed, together with the positional relationship between a cam follower and a cam slot.

**[0026]** Fig. 13 shows in vertical section the freezing unit, where the water tray is tilting, and the water remaining therein is partly discharged.

**[0027]** Fig. 14 shows in vertical section the freezing unit, where the water tray is stopping in the tilted pos-

ture, and the ice pieces are being released while the rocking plate is retained in a tilted posture at a position slightly above the water tray.

**[0028]** Fig. 15 shows in vertical section the freezing unit, where the water tray is reset to the original horizontal posture, and water to be frozen is being added afresh to the residual water.

**[0029]** Fig. 16 shows in exploded perspective view the major portion of the cam control mechanism in an ice making machine according to a second embodiment of the invention.

**[0030]** Fig. 17 shows schematically in vertical section the ice making machine in which the cam control mechanism according to the second embodiment of the invention is employed.

**[0031]** Fig. 18 shows in partially exploded perspective view the freezing unit in which the cam control mechanism is employed.

**[0032]** Fig. 19 shows in vertical section the major portion of the freezing unit shown in Fig. 18.

**[0033]** Fig. 20 shows in partially cut-away front elevation the water tray tilting mechanism and the rocking plate rocking mechanism shown in Fig. 18.

**[0034]** Fig. 21 shows schematically in perspective view the freezing unit shown in Fig. 18 disposed in a box-like chamber.

**[0035]** Fig. 22 shows in partially cut-away front elevation the freezing unit shown in Fig. 18.

**[0036]** Fig. 23 shows in perspective view the appearance of the ice making machine.

**[0037]** Fig. 24 shows in partially cut-away side view the freezing unit shown in Fig. 19, where the water tray is tilted.

**[0038]** Fig. 25 shows a diagram of control circuit connected to the cam control mechanism.

**[0039]** Fig. 26 shows an explanatory view of the freezing unit under rocking of the rocking plate during the freezing operation of the ice making machine and the rocking mechanism assuming a corresponding posture.

**[0040]** Fig. 27 shows an explanatory view of the freezing unit after completion of the freezing operation in the ice making machine according to the second embodiment of the invention and the rocking mechanism assuming a corresponding posture.

**[0041]** Fig. 28 shows an explanatory view of the freezing unit after completion of the freezing operation in the ice making machine and the rocking mechanism assuming a corresponding posture, where the rocking protrusion of a rocking member is retracted from the tilting orbit of the engagement piece of the rocking plate.

**[0042]** Fig. 29 shows an explanatory view of the freezing unit after completion of the freezing operation in the ice making machine, and the rocking mechanism and tilting mechanism assuming corresponding postures respectively.

**[0043]** Fig. 30 shows an explanatory view of the freezing unit in the ice making machine, where the water tray is stopped in the tilted posture, together with the posi-

tional relationship between the cam plate of the tilting mechanism assuming a corresponding posture and the seventh and ninth switches.

**[0044]** Fig. 31 shows an explanatory view of the freezing unit in the ice making machine, where the water tray is resetting, together with the positional relationship between the cam plate of the tilting mechanism assuming a corresponding posture and the seventh and ninth switches.

**[0045]** Fig. 32 shows an explanatory view of the freezing unit in the ice making machine, where the water tray is counter-tilted over the horizontal posture, together with the positional relationship between the cam plate of the tilting mechanism assuming a corresponding posture and the seventh and ninth switches.

**[0046]** Fig. 33 shows an explanatory view of the motions of the rocking mechanism for the rocking plate in the ice making machine, where the rocking protrusion of the rocking member is retracting from the tilting orbit of the engagement piece of the rocking plate after detection of completion of the freezing operation.

**[0047]** Fig. 34 shows a timing chart of control to be effected by the cam control mechanism.

## DESCRIPTION OF PREFERRED EMBODIMENTS

**[0048]** The cam control mechanism in the ice making machine according to this invention will be described below by way of preferred embodiments referring to the attached drawings.

(General constitution of the ice making machine)

**[0049]** Figs. 7 and 8 show schematically, in cross section and perspective view, respectively, the overall structure of the ice making machine in which the cam control mechanism according to a first embodiment of the invention is employed. A rectangular housing 10 constituting the main body of the ice making machine basically has defined therein a lower machine chamber 14 in which the freezing system including a compressor CM and a condenser 18 are housed, an ice bin 12 which can be closed by a door 26, disposed above the lower machine chamber 14, surrounded with a heat insulating material and a freezing unit 20 disposed in the ice bin 12 at an upper position thereof. As will be described later referring to Figs. 4 and 5, the freezing unit 20 has a water tray 24 in which a predetermined level of water to be frozen is carried and a freezing base plate 34 having freezing fingers 36 to be dipped in the water to be frozen, wherein the water tray 24 is tilted to a predetermined angle upon switching to the ice releasing operation to discharge the water remaining therein to the outside of the machine through a water collecting section 28 and drain pipe 30 as well as to release the ice pieces into the ice bin 12.

(Freezing unit)

**[0050]** Fig. 5 shows minutely a vertical sectional view of the freezing unit 20, in which the water tray 24, the structure of which is as shown in Figs. 4 and 6, is designed to carry a predetermined level of water to be frozen in the freezing chamber 32 defined therein. In other words, the freezing chamber 32 is defined by a rectangular bottom 24a of the water tray 24 and four walls 24b, 24c, 24d, 24e standing upright from the four sides of the rectangular bottom 24a, respectively. A pair of supporting members 50 are fixed to the outer surfaces of the shorter walls 24d, 24e opposing to each other. As shown in Fig. 6, the supporting member 50 fixed to the wall 24d has a cam portion 50a bending diagonally downward at a position outer than the water tray 24, and a cam slot 54 is defined in the cam portion 50a, in which a cam follower 56 formed eccentrically on a cam disc 58 (to be described later) is fitted slidably. A tongue 49 having a through hole is formed adjacent to the corner of the bent portion in each supporting member 50 at a position outer than the water tray 24, and a pivotal shaft 52 is inserted to these through holes. The pivotal shaft 52 is fixed to the main body of the ice making machine, so that the water tray 24 may be tilted downward or reset to the horizontal posture on the pivotal shaft 52 under the cam action with the rotation of an actuator motor AM connected to the cam disc 58, as shown in Figs. 13 to 15.

(Freezing system)

**[0051]** Fig. 9 shows a schematic constitution of the freezing system to be employed in the ice making machine. The cooling medium vaporized under compression by the compressor CM is passed through a delivery pipe 33, liquefied by the condenser 18 and, after desiccation in a dryer 35, decompressed through a capillary 37. The thus treated cooling medium then flows into an evaporator 22 to be allowed to expanded suddenly to carry out heat exchange with the freezing base plate 32 and cool the freezing fingers 36 below the freezing point. The portion of the cooling medium vaporized in the evaporator 22 and the unvaporized portion of the cooling medium flow into an accumulator 39 in the form of gas-liquid mixture, where they are separated into the respective phases. The gaseous phase cooling medium is recirculated to the compressor CM through a suction pipe 41, while the liquid phase cooling medium is accumulated in the accumulator 39. Further, a hot gas pipe 43 branching out of the delivery pipe 33 of the compressor CM is connected to the inlet side of the evaporator 22 through a hot gas valve HV. The hot gas valve HV is open during the ice releasing operation to bypass the heated medium (hereinafter referred to as hot gas) delivered from the compressor CM through the evaporator 22 via the hot gas pipe 43 to heat the freezing fingers 36 and allow the ice pieces to drop by their own weights. Meanwhile, the hot gas delivered from the evaporator

22 heats the liquid phase cooling medium staying in the accumulator 39 to vaporize it, and the thus vaporized cooling medium is recirculated to the compressor CM through the suction pipe 41. Incidentally, the reference mark FM denotes a fan motor for the condenser 18.

(Water discharging mechanism of water tray)

**[0052]** As shown in Figs. 5 and 6, the water tray 24 has a drainage for discharging the water remaining in the freezing chamber 32 whenever the water tray 24 is tilted. More specifically, a water chute 38 is integrally formed on the bottom of the water tray 24 to extend diagonally downward therefrom, and a water collecting section 28 for discharging the thus collected water to the outside of the machine is defined in the ice bin 12 at an upper position (see Fig. 7). As shown in Fig. 5, the one longer wall on the free end side of the water tray 24 (locating opposite to the pivotal shaft 52) constitutes a dam plate 42, and an inner wall 24c covering the dam plate 42 is integrally formed with the water tray 24. Incidentally, the lower free end of the inner wall 24c is positioned adjacent to the bottom of the water tray 24 with a very small clearance therebetween. Accordingly, as shown in Fig. 5, the water to be frozen flows through the lower free end of the inner wall 24c to the dam plate 42, and flows further over the dam plate 42 to be discharged to the water chute 38. In other words, the water to be frozen to be carried in the freezing chamber 32 can be maintained at a predetermined level by the dam plate 42. Upon switching to the ice releasing operation (to be described later), the water tray 24 is tilted downward 24, as shown in Fig. 13, to discharge the water remaining therein through the water chute 38. When the water tray 24 is stopped in the tilted posture, a part of the freezing water is held by the dam plate 42 to remain therein (see Fig. 14). The residual water is combined with another portion of water to be frozen supplied afresh from a water supply pipe 68 to cool effectively the temperature of the water to be frozen entirely.

**[0053]** The freezing base plate 34 is secured horizontally at an upper position of the rectangular housing 10, and the evaporator 22 led out of the freezing system housed in the machine chamber 14 is disposed zigzag on the upper surface of the freezing base plate 34. Meanwhile, a plurality of freezing fingers 36 protrude downward from the lower surface of the freezing base plate 34 at predetermined intervals, and these freezing fingers 36 are adapted to be dipped in the water to be frozen carried in the water tray 24 during the freezing operation. As heat exchange with the cooling medium in the evaporator 22 is proceeded by operating the freezing system, the freezing fingers 36 are cooled and maintained at a temperature of 0°C or lower to allow ice pieces 70 to grow gradually around the freezing fingers 36, as shown in Fig. 12.

(Cam control mechanism)

**[0054]** As shown in Fig. 1, a first cam 13, a second cam 15 and a third cam 17 are disposed coaxially to the rotary shaft 11 of the actuator motor AM at predetermined intervals. Meanwhile, a first switch SW<sub>1</sub>, a second switch SW<sub>2</sub> and a third switch SW<sub>3</sub> are fixed to the main body of the ice making machine, and cam actions are designed to be added to the rotation of the actuator motor AM so as to control the following motions to be caused by the operation of the actuator motor AM:

- (1) tilting or resetting of the water tray 24 and stopping it at such postures;
- (2) opening and closing of the hot gas valve HV; and
- (3) opening and closing of the water valve WV for supplying water to be frozen, respectively. More specifically, the first cam 13 assumes a form of disc with a predetermined diameter having a couple of recesses 13a, 13b formed on the circumference thereof, and the roller of a lever 19 extending from the first switch SW<sub>1</sub> is designed to be abutted against the circumference of the first cam 13 and engaged with the recess 13a or 13b in accordance with a predetermined timing. These recesses 13a, 13b are not formed symmetrically on each side of the center of the cam with 180° angles but with a predetermined central angle therebetween, as shown in Fig. 1. Provided that the circumferential section formed between the recesses 13a, 13b with a larger central angle is to be referred to as A<sub>1</sub>, while the circumferential section formed therebetween with a smaller central angle is to be referred to as A<sub>2</sub>, the circumferential section A<sub>1</sub> assumes the cam surface for controlling tilting of the water tray 24, and the circumferential section A<sub>2</sub> assumes the cam surface for controlling resetting of the water tray 24 to the horizontal posture, as will be described later. The first switch SW<sub>1</sub> is connected to a first relay X<sub>1</sub> in the control circuit shown in Fig. 2 to control tilting and resetting of the water tray 24 and stopping thereof at such postures. The timing of the cam actions between the first cam 13 and the first switch SW<sub>1</sub> is as shown in the timing chart of Fig. 3.

**[0055]** The second cam 15 also assuming a form of disc has a circumferential section having a central angle of about 270°, and the roller of a lever 21 extending from the second switch SW<sub>2</sub> is designed to be abutted against the circumference of the cam 15 and engaged with the recess having a central angle of about 90° in accordance with a predetermined timing. The second switch SW<sub>2</sub> is connected to a second relay X<sub>2</sub>, as shown in Fig. 2, and controls opening and closing of the hot gas valve HV in cooperation with the opening and closing of a normally open contact X<sub>2-a</sub> (as will be described later). The third cam 17 has a circumferential cam surface having a predetermined central angle, and the roller of a

lever 23 extending from the third switch SW<sub>3</sub> is designed to be abutted against the circumference of the third cam 17. The third switch SW<sub>3</sub> is turned on when the lever 23 of the third switch is abutted against the cam surface. The third switch SW<sub>3</sub> is connected to a third relay X<sub>3</sub>, as shown in Fig. 2, and controls opening and closing of the water valve WV interlocking with a normally open contact X<sub>3-a</sub> (as will be described later). Timing of the cam actions between the second cam 15 and the second switch SW<sub>2</sub> and that between the third cam 17 and the third switch SW<sub>3</sub> will be shown in the timing chart of Fig. 3.

(Rocking plate)

**[0056]** An L-shaped rocking plate 44 is disposed in the freezing chamber 32 defined in the water tray 24 so as to be able to be rocked freely therein by the rotation of the rocking motor RM. More specifically, the rocking plate 44 is of a planar plate having a vertical portion 45 and also a plurality of through holes 46 defined at predetermined intervals thereon, as shown in Fig. 6. The circumferential size of the rocking plate 44 is designed to be slightly smaller than the inner circumferential size of the bottom 24a of the freezing chamber 32, and the upper end portion of the vertical portion 45 is rolled outward to form through holes on each side, in which a rocking shaft 48 is inserted. The end portions of the rocking shaft 48 is designed to be fitted into the through holes 53a of tongues 53 formed on the outer surfaces of the side walls of the water tray 24. With the rocking plate 44 pivotally supported by the rocking shaft 48, the rocking plate 44 is brought into intimate contact with the bottom of the freezing chamber 32, as shown in Fig. 5.

**[0057]** As shown in Fig. 6, the rocking plate 44 also has formed integrally therewith a vertical tongue 59 on one shorter edge thereof, and an engagement pin 61 extends outward horizontally therefrom. Meanwhile, as shown in Figs. 4 and 6, the rocking motor RM is disposed on the inner wall surface of the main body of the ice making machine in such a way that it can slightly be shifted vertically as will be described later. An engagement piece 62 protruding from the rotary shaft of the motor RM is designed to be engageable with the engagement pin 61 of the rocking plate 44 locating above the engagement piece 62. Accordingly, by rotating the rocking motor RM counterclockwise, the engagement piece 62 is rotated under engagement with the engagement pin 61 to lift the rocking plate 44 from the bottom of the freezing chamber 32 to a predetermined height, as shown in Fig. 10, and then allow it to drop onto the bottom of the freezing chamber 32 by its own weight upon disengagement of the engagement piece 62 from the engagement pin 61, as shown in Fig. 11. Namely, the rocking plate 44 repeats such rocking motion in the freezing chamber 32 on the rocking shaft 48 by rotating the rocking motor RM during the freezing operation, whereby the water to be frozen can constantly be agi-

tated. Incidentally, since the rocking plate 44 has through holes 46, the water to be frozen flows through these through holes 46 upward and downward, whereby agitation of the water to be frozen can further be accelerated. However, these through holes 46 are not inevitable, but can be omitted, as desired. Further, while the rocking plate 44 is designed to be tilted as the water tray 24 is tilted before the ice releasing operation (to be described later) is started, a stopper 63 extending horizontally from the rectangular housing 10 is disposed on the tilting orbit of the engagement pin 61 provided on the rocking plate 44. By allowing the engagement pin 61 to engage with the stopper 63 during the process that the rocking plate 44 is tilted together with the water tray 24, the rocking plate 44 is separated from the water tray 24 and assumes there a predetermined tilted posture.

(Switch SW<sub>4</sub> for detecting completion of ice formation and switch Th for detecting completion of ice releasing operation)

**[0058]** As shown in Figs. 4 and 5, the rocking motor RM is disposed to be slightly shiftable vertically via fixtures 25 provided on the inner wall surface of the main body of the ice making machine and normally locate at the uppermost position. Upon application of a predetermined external force to the motor RM, the motor RM is designed to be shifted downward with a predetermined stroke. Meanwhile, the lever 27 of a switch SW<sub>4</sub> such as a microswitch for detecting completion of ice formation locates on the descending orbit of the motor RM so as to be able to be abutted against the rocking motor RM as it descends to turn on the switch SW<sub>4</sub>. Namely, as will be described later referring to Fig. 12, when ice pieces 70 are formed around the freezing fingers 36 as the freezing operation proceeds, the rocking plate 44 is brought into contact with these ice pieces 70 in its upward stroke to exert a downward counterforce to the rocking motor RM through the engagement pin 61 and engagement piece 62. Accordingly, the rocking motor RM starts descending from the uppermost position to depress the lever 27 of the switch SW<sub>4</sub> in its descending process to turn on the switch SW<sub>4</sub>, and thus completion of ice formation in the freezing unit 20 is detected. Meanwhile, as shown in Figs. 4 and 5, a thermometal switch Th for detecting completion of ice releasing operation is disposed on the upper surface of the freezing base plate 34 in the freezing unit 20, which is turned on by the sudden temperature rise caused by the dropping off of the ice pieces 70 from the freezing fingers 36 to rotate the actuator motor AM.

(Example of electric control circuit)

**[0059]** Fig. 2 shows an electric control circuit in the ice making machine according to the first embodiment of the invention, in which a fuse F and a switch SW<sub>5</sub> for detecting ice fullness are interposed in series between

a power supply line R and a joint D, and a compressor CM is interposed between the joint D and a line T. Likewise, (1) a first switch SW<sub>1</sub> for the actuator motor AM shown in Fig. 1 and a relay X<sub>1</sub>; (2) a second switch SW<sub>2</sub> for supplying hot gas shown in Fig. 1 and a second relay X<sub>2</sub>; (3) a third switch SW<sub>3</sub> for supplying water to be frozen shown in Fig. 1 and a relay X<sub>3</sub>; and (4) a switch SW<sub>4</sub> for detecting completion of ice formation shown in Fig. 4 and a relay X<sub>4</sub> are interposed in series respectively between the joint D and the line T. Meanwhile, a timer  $\text{\textcircled{T}}$  for controlling timing of driving the rocking motor RM is also interposed, with one terminal thereof being connected to the line T, while the other terminal being connected to the joint D through a normally open contact X<sub>3-a<sub>2</sub></sub> of the relay X<sub>3</sub>. Incidentally, a second normally open contact T-a<sub>2</sub> for the timer  $\text{\textcircled{T}}$  is disposed in parallel to the normally open contact X<sub>3-a<sub>2</sub></sub> to achieve self-hold thereof.

**[0060]** One terminal of the actuator motor AM is connected to the line T, while the other terminal thereof is connected to the joint D through the elements connected in parallel: (1) a normally open contact X<sub>4-a</sub> for the relay X<sub>4</sub>; (2) an X<sub>1-a</sub> for the relay X<sub>1</sub>; and (3) the thermometal switch Th for detecting completion of ice releasing operation. Between the joint D and the line T are also interposed in series respectively (1) the rocking motor RM and a first normally open contact T-a<sub>1</sub> for the timer  $\text{\textcircled{T}}$ ; (2) the hot gas valve HV and the X<sub>2-a</sub> for the second relay X<sub>2</sub>; and (3) the waver valve WV for supplying water to be frozen and the normally open contact X<sub>3-a<sub>1</sub></sub> for the relay X<sub>3</sub>.

**[0061]** Next, the actions of the cam control mechanism according to the first embodiment of the invention will be described referring to the timing chart shown in Fig. 3. Before the freezing operation is started, the water tray 24 is maintained in a horizontal posture, as shown in Fig. 5, and water to be frozen is supplied to the freezing chamber 32 defined in the water tray 24 through the water supply pipe 68. Feeding and stopping of the water from the water supply valve 68 is carried out by controlling opening and closing of the water valve WV by the cam action between the third cam 17 and the third switch SW<sub>3</sub>. Even if an excess amount of water should be supplied to the freezing chamber 32, the excess portion of water flows over the dam plate 42 and discharged to the outside of the machine through the water chute 38 and the water collecting section 28, as described above.

**[0062]** A cooling medium is supplied to the evaporator 22 from the circulation pipe of the freezing system, and cooling of the freezing fingers 36 formed on the freezing base plate 34 is started by the heat exchange action of the cooling medium. Since the freezing fingers 36 are dipped in the water to be frozen, the water starts to freeze around the freezing fingers 36 and grows gradually into inverted dome-shaped ice pieces 70, as shown in Fig. 12. During such freezing operation, the rocking motor RM is continuously rotated, the rotational timing of which is set by the timers  $\text{\textcircled{T}}$ . Accordingly, the engage-

ment piece 62 provided on the rotary shaft of the motor RM is engaged with the engagement pin 61 provided on the vertical tongue 59 to lift the rocking plate 44, as shown in Fig. 10. Upon disengagement of the engagement piece 62 from the engagement pin 61, the rocking plate 44 drops by its own weight and is abutted against the bottom 24a of the freezing chamber 32, as shown in Fig. 11. Thus, the rocking plate 44 repeats such rocking motion in the water to be frozen in the freezing chamber 32 during the freezing operation to constantly agitate the water. Moreover, since through holes 46 are formed on the rocking plate 44, the water to be frozen flows through these through holes 46 as the rocking plate 44 is rocked to cause jet streams which further accelerate the agitation of the water to be frozen. Since the water to be frozen is constantly maintained in a dynamic state, as described above, opacification to white of the ice pieces 70 to be formed around the freezing fingers 36 can be prevented, and transparent and clear ice pieces 70 can be obtained.

**[0063]** As shown in Fig. 12, upon formation of inverted dome-like ice pieces 70 fully around the freezing fingers 36, the rocking plate 44 is brought into contact with the ice pieces 70 in its upward stroke and finally exerts a downward counterforce to the rocking motor RM through the engagement pin 61 and the engagement piece 62. Accordingly, the rocking motor RM starts descending from the uppermost position to depress the lever 27 of the switch SW<sub>4</sub> for detecting completion of ice formation to turn on the switch SW<sub>4</sub>, and thus completion of ice formation in the freezing unit 20 is detected. Whereupon the relay X<sub>4</sub> shown in Fig. 2 is actuated to close the normally open contact X<sub>4</sub>-a which interlocks therewith and start rotation of the actuator motor AM. Thus, the cam disc 58 is turned clockwise to allow the cam follower 56 disposed eccentrically thereto to slide along the cam slot 54 formed on the cam 50a, and thus the water tray 24 starts tilting downward. By this tilting motion of the water tray 24, the water remaining in the freezing chamber 32 flows along the inner wall 24c and over the dam plate 42 to the water chute 38, in turn, to the water collecting section 28. Incidentally, while the lever 19 of the first switch SW<sub>1</sub> shown in Fig. 1 is engaged with the recess 13a of the first cam 13 immediately before the actuator motor AM is rotated, the lever 19 rides on the circumferential section A<sub>1</sub> when the motor AM is started to turn on the switch SW<sub>1</sub>. Thus, the relay X<sub>1</sub> is actuated to close the normally open contact X<sub>1</sub>-a which interlocks therewith. Accordingly, the counterforce applied to the rocking motor RM is released by the tilting of the water tray 24, and the rotation of the actuator motor AM is continued by the closure of the normally open contact X<sub>1</sub>-a even after the ice formation completion detection switch SW<sub>4</sub> is turned off.

**[0064]** Upon engagement of the lever 19 with the recess 13b of the first cam 13, the switch SW<sub>1</sub> is turned off to release actuation of the relay X<sub>1</sub> and open the normally open contact X<sub>1</sub>-a which interlocks therewith. Ac-

cordingly, the water tray 24 stops at a predetermined angle, as shown in Fig. 14. In this state, while a portion of the water to be frozen remains in the freezing chamber 32 due to the presence of the dam plate 42, such residual water, fully cooled during the previous freezing operation, is mixed with another portion of water to be supplied afresh to cool effectively the thus combined water to be frozen. Meanwhile, the ice pieces 70 formed around the freezing fingers 36 are exposed as such by tilting the water tray 24. Further, since the rocking plate 44 is also tilted as the water tray 24 is tilted, the engagement pin 61 is disengaged from the engagement piece 62 of the rocking motor RM. In the process that the water tray 24 is stopped in the tilted posture, the engagement pin 61 of the rocking plate 44 is engaged with the stopper 63, as shown in Fig. 14, so that the rocking plate 44 is allowed to locate diagonally above the bottom 24a of the freezing chamber 32 in the water tray 24 which stops later in the tilted posture. The rocking plate 44 also functions as a chute for guiding the ice pieces 70 dropping from the freezing fingers 36 into the ice bin 12.

**[0065]** In the process of tilting the water tray 24, the lever 21 of the second switch SW<sub>2</sub> is engaged with the recessed circumferential section (with a central angle of about 90°) of the second cam 15 to turn on the switch SW<sub>2</sub> and actuate the second relay X<sub>2</sub> shown in Fig. 2. Whereupon the normally open contact X<sub>2</sub>-a interlocking with the relay X<sub>2</sub> is closed to open the hot gas valve HV and supply a hot gas instead of the cooling medium to the evaporator 22 in accordance with the timing chart shown in Fig. 3. Thus, the freezing fingers 36 are heated rapidly through the freezing base plate 34. Accordingly, the bondage between the freezing fingers 36 and the ice pieces 70 is released, and the ice pieces 70 drop by their own weights, slide on the upper surface of the rocking plate 44 maintained in a predetermined tilted posture by the stopper 63 and are guided into the ice bin 12 locating below.

**[0066]** The negative temperature load applied to the freezing base plate 34 is released by the dropping of the ice pieces 70, and the temperature of the freezing base plate 34 is suddenly elevated by the passage the hot gas through the evaporator 22. This temperature rise is detected by the thermometal switch Th and turned on to allow the actuator motor to resume its rotation. Accordingly, the cam portion 50a is turned counterclockwise on the pivotal shaft 52 under the cam action of the cam disc 58, cam follower 56 and cam slot 54, to allow the water tray 24 to turn counterclockwise and start resetting to the horizontal posture. As the motor AM resumes rotation, the second cam 15 resumes rotation to allow the lever 21 extending from the second switch SW<sub>2</sub> to ride on the circumferential cam surface of the second cam 15 and turn off the switch SW<sub>2</sub>. Thus, the actuation of the second relay X<sub>2</sub> shown in Fig. 2 is released to open again the normally open contact X<sub>2</sub>-a which interlocks therewith and close the hot gas valve HV. Accordingly, supply of the cooling medium to the

evaporator 22 is started again. Further, as the motor AM resumes rotation, the lever 23 of the third switch SW<sub>3</sub> is engaged with the circumferential cam surface of the third cam 17 to turn on the switch SW<sub>3</sub>, whereby the third relay X<sub>3</sub> shown in Fig. 2 is actuated to close the normally open contact X<sub>3</sub>-a<sub>1</sub> which interlocks therewith and open the water valve WV to supply water to be frozen to the freezing chamber 32. Upon disengagement of the third cam 17 from the third switch SW<sub>3</sub>, the switch SW<sub>3</sub> is turned off to release actuation of the third relay X<sub>3</sub> to open the normally open contact X<sub>3</sub>-a<sub>1</sub>, as well as, to close the water valve WV and stop supply of water to be frozen.

**[0067]** Meanwhile, with the rotation of the actuator motor AM, the lever 19 of the first switch SW<sub>1</sub> engaged with the recess 13b of the first cam 13 rides on the cam surface on the circumferential section A<sub>2</sub> to actuate the relay X<sub>1</sub> and open the normally open contact X<sub>1</sub>-a, whereby the motor AM is energized in cooperation with the thermometal switch Th which is closed immediately after cooling of the freezing base plate 34 is resumed by supplying the cooling medium to the evaporator 22, as described above. Upon engagement of the lever 19 of the first switch SW<sub>1</sub> with the recess 13a, as the first cam 13 is rotated, the switch SW<sub>1</sub> is opened to release actuation of the relay X<sub>1</sub> and open the normally open contact X<sub>1</sub>-a. Thus, the rotation of the actuator AM is stopped to allow the water tray 24 to stop in the horizontal posture.

**[0068]** Incidentally, when the third switch SW<sub>3</sub> for opening the water valve WV is turned on, the normally open contact X<sub>3</sub>-a<sub>2</sub> which interlocks with the relay X<sub>3</sub> to energize the timers  $\text{\textcircled{T}}$ . After passage of a predetermined time period set in the timer  $\text{\textcircled{T}}$ , the first normally open contact T-a<sub>1</sub> which interlocks therewith is closed to start rotation of the rocking motor RM to allow the rocking plate 44 to resume its rocking motion during the freezing operation. Meanwhile, the second normally open contact T-a<sub>2</sub> of the timer  $\text{\textcircled{T}}$  is closed to attain self-hold of the timers  $\text{\textcircled{T}}$ . After passage of the preset time period in the timer  $\text{\textcircled{T}}$ , the first and second normally open contacts T-a<sub>1</sub> and T-a<sub>2</sub> are opened to stop rotation of the rocking motor RM.

(Schematic constitution of the ice making machine according to second embodiment)

**[0069]** Figs. 17 and 23 show schematically, in cross section and perspective view, respectively the overall structure of the ice making machine in which the cam control mechanism according to a second embodiment of the invention is employed. For convenience's sake, it should be appreciated that the expressions "front", "rear", "right" and "left" referred to herein are with respect to the front view of the ice making machine. A rectangular housing 110 constituting the main body of the ice making machine basically has defined therein a lower machine chamber 112 in which the freezing system

including a compressor CM and a condenser 111 are housed, a box-like ice bin 114, disposed above the lower machine chamber 112, surrounded with a heat insulating material and having an ice chamber 183 defined therein, and a freezing unit 115 disposed in the ice bin 114 at an upper position thereof. As will be described later referring to Figs. 18 and 19, the freezing unit 115 has a water tray 116 in which a predetermined level of water to be frozen is carried and a freezing base plate 118 having freezing fingers 117 to be dipped in the water to be frozen, wherein the water tray 116 is tilted to a predetermined angle upon switching to the ice releasing operation to discharge the water remaining in the water tray 116 to the outside of the machine through a water collecting section 119 and drain pipe 120 as well as to release the ice pieces 121 into the ice chamber 183. Incidentally, an ice discharging mechanism 113 (to be described later) is disposed to the ice bin 114, and the ice pieces 121 stored in the ice chamber 183 are adapted to be discharged thereby to the outside of the machine.

(Outer structure of rectangular housing)

**[0070]** As shown in Fig. 23, the rectangular housing 110 consists of a main frame 122 surrounding all of the members described above and a front panel 123 disposed to the front surface of the main frame 122, and assumes as a whole a slim body having a very narrow transversal size. The front panel 123 is made of a synthetic resin and formed into the shape as shown in Fig. 23, in which a downward opening 123a for discharging the ice pieces 121 defined in the ice bin 114 is formed around at the half height thereof to be in alignment with the outlet 114a (see Fig. 17). A hollow table 124 is adapted to be removably fitted to the space below the opening 123a, on which a vessel such as a glass can be loaded whenever the ice pieces 121 are to be delivered. This table 124 has on the upper surface thereof a multiplicity of slits 124a for draining the water drops dripping from the outlet 114a and opening 123a to collect them therein so as to prevent splitting of the water drops around the machine. The front panel 123 also has a power supply indication lamp L and a push button 125 for the sixth switch SW<sub>6</sub> for discharging the ice pieces 121 stored in the ice chamber 183 provided on the upper part thereof extending above the opening 123a, and the ice discharging unit 113 is designed to be operated to discharge the ice pieces 121 stored in the ice chamber 183 through the outlet 114a and the opening 123a, only while the push button 125 is depressed to turn on the sixth switch SW<sub>6</sub>.

**[0071]** An opening (not shown) is defined on the bottom of the rectangular housing 110 to communicate to the machine chamber 112. The opening is designed to be removably covered by a filter 126. The filter 126 functions to collect dusts in the outer air to be introduced to the machine chamber 112 for cooling the condenser 111 thereby to prevent reduction in the cooling capacity

thereof to be caused by the clogging of the condenser. Incidentally, the filter 126 is also designed to be easily drawn out from the front side of the rectangular housing 110.

(Inner cover)

**[0072]** As shown in Fig. 17, an inner cover 127 is removably applied to the front side of the ice bin 114, on which the actuator motor AM for tilting the water tray 116 in the freezing unit 115, the rocking motor RM for rocking a rocking plate 154 (to be described later) and a discharging motor GM for the ice discharging unit 113 are all mounted at the front surface thereof. Accordingly, the respective motors AM, RM, GM and members incidental thereto can all be exposed by removing the front panel 123, whereby maintenance and repair thereof can be facilitated. Meanwhile, the inner cover 127 having already mounted thereon the motors AM, RM, GM can be fitted on the front side of the ice bin 114, leading to reduction in the time required for the assembly of the automatic ice making machine, advantageously.

(Freezing unit)

**[0073]** Fig. 19 shows minutely a vertical sectional view of the freezing unit 115, and the water tray 116, the structure of which is as shown in Fig. 18, is designed to carry a predetermined level of water to be frozen in the freezing chamber 129 defined therein. In other words, the freezing chamber 129 is defined by a rectangular bottom 116a of the water tray 116 and four walls 116b, 116c, 116d, 116e standing upright from the respective sides of the rectangular bottom 116a. A plurality of pintles 130, are integrally formed and aligned horizontally on the outer surface of the right wall 116e in Fig. 18. These pintles 130 are pivotally fitted in the through holes 132a defined in the brackets 132 holding the freezing base plate 118 at an upper position in the ice bin 114, so that the water tray 116 can be pivoted sideways on the pintles 130 (see Fig. 21). Incidentally, a water supply pipe 149 for supplying water to be frozen is removably disposed to the freezing base plate 118 at an appropriate position (to be described later), which is designed to supply a predetermined amount of water to be frozen to the freezing chamber 129 by opening the water valve WV in accordance with the timing to be described later (see Fig. 34). Since the freezing unit 115 can easily be separated from the brackets 132 by removing the inner cover 127 from the ice bin 114, assembly or maintenance and repair of the ice making machine can be facilitated, advantageously.

**[0074]** Meanwhile, a square hole 130a is defined in the foremost pindle 130, in which a square shaft 133a protruding from the free end of a pivotal shaft 133 (to be described later) is fitted. The pivotal shaft 133 is pivotally supported on the inner cover 127, and thus the water tray 116 is designed to be tilted downward and reset up-

ward on the pintles 130 with the rotation of the actuator motor AM mounted on the inner cover 127, as shown in Figs. 29 to 32. Such constitution of the water tray 116, which is designed to be tilted sideways, can reduce width of the ice making machine. Incidentally, since the pintles 130 are formed integrally with the water tray 116 so that the water tray 116 can be tilted or reset by turning the pintles 130, not only the rigidity of the water tray itself can be enhanced, but also the tilting and resetting of the water tray 16 can be carried out smoothly. Moreover, the pintles 130 are formed horizontally along the longitudinal direction of the water tray 116 to allow the load of the water tray 116 to be applied evenly to the pintles, so that the water tray 116 can be maintained in the horizontal posture without tilting in the longitudinal direction thereof.

(Water tray tilting mechanism)

**[0075]** A cylindrical bearing 134 protruding forward is provided on the inner cover 127 at a position corresponding to the location of the pintles 130 of the water tray 116, and the pivotal shaft 133 is pivotally supported in the through hole 134a defined in the bearing 134. The square shaft 133a formed on the other end of the pivotal shaft 133 is fitted in the square hole 130a of the pindle 130. A lever 133b is formed integrally with the pivotal shaft 133 to extend radially from the front end portion thereof, and a protrusion 133c is formed on the front surface of the lever 133b at the free end portion thereof. As shown in Figs. 16 and 18, a cam plate 136, which is a disc having a predetermined diameter and a notch on the circumference thereof, is disposed to the rotary shaft of the actuator motor AM, mounted to the inner cover 127 through a bracket 135, protruding forward through the bracket 35. A connection rod 137 is pivotally supported eccentrically at one end portion thereof onto the front surface of the cam plate 136, and the other end portion of the connection rod 137 has a slot 137a in which the protrusion 133c of the lever 133b formed integrally with the pivotal shaft 133 is slidably engaged. Accordingly, the pivotal shaft 133 can be pivoted reciprocatingly within a predetermined range of angle through the cam plate 136 and the connection rod 137 by rotating the actuator motor AM, whereby to tilt the water tray 116. Incidentally, since the actuator motor AM is for pivoting the pintles 130 on which the water tray 116 is tilted, it may have a small output power.

**[0076]** The water tray 116 is designed to maintain a horizontal posture with the engagement protrusion 133c of the lever 133b being abutted against the lower extremity (the side directing to the supporting portion of the cam plate 136) of the slot 137a in the connection rod 137 (see Fig. 20). Meanwhile, an elliptic regulating piece 133d which can be inserted through the slot 137a of the connection rod 137 is disposed to the front end of the protrusion 133c, and this regulating piece 133d is elongated in the radial direction of the protrusion 133c, so

that the connection rod 137 may not easily be disengaged from the protrusion 133c under engagement of the protrusion 133c with the slot 137a. Further, the lever 133b is designed to be shiftable within the allowance of the slot 137a relative to the connection rod 137 so as to tolerate any errors in the positions of the lever 133b and the connection rod 137 when the water tray 116 is stopped in the tilted posture. Incidentally, an engagement piece 133e is formed on the rear side of the lever 133b, with which one end of a torsion spring 139 (to be described later) is designed to urge a fixture 138 (to be described later), on which the rocking motor (RM) is mounted, in a predetermined direction.

(Water discharging mechanism of water tray)

**[0077]** As shown in Figs. 19 and 24, the water tray 116 has a drainage for discharging the water remaining in the freezing chamber 129 whenever the water tray 116 is tilted. More specifically, an auxiliary chamber 146 is defined backward on the rear wall 116c of the water tray 116 at that end portion which can assume the lowest position when the water tray 116 is tilted, and a duct 147 having a predetermined length is connected to the outer (rear) wall surface of the auxiliary chamber 146. The water collecting section 119 for discharging the thus collected water to the outside of the machine defined at the rear side of the ice bin 114 locates below the duct 147. The auxiliary chamber 146 and the freezing chamber 129 are demarcated with a dam plate 148 which is lower than the wall 116c. Accordingly, the water to be frozen supplied to the water tray 116 is adapted to flow over the upper end of the dam plate 148 and to be discharged to the water collecting section 119 through the duct 147. In other words, the water to be frozen to be carried in the freezing chamber 129 can be maintained to a predetermined level by this dam plate 148. Upon switching to an ice releasing operation, the water tray 116 is tilted downward to discharge the water remaining therein through the duct 147, as shown in Fig. 24. With the water tray 116 stopping in this tilted posture, a part of the water to be frozen still remains therein due to the presence of the dam plate 148 (see Fig. 30) and combined with the water supplied afresh from the water supply pipe 149 for the next cycle of freezing operation to accelerate cooling of the water to be frozen.

**[0078]** Incidentally, the duct 147 also serves as a stopper for the water tray 116, which is abutted against the upper edge defining the water collecting section 119 and the ice bin, when the water tray 116 is tilted downward. Since the protrusion 133c of the pivotal shaft 133 is designed to be shiftable in the slot 137a of the connection rod 137 in the tilting mechanism, any possible load to be applied to the tilting mechanism to be caused by the displacement between the stopping position of the tilted water tray 116 and the stopping position of the actuator motor AM can be obviated.

**[0079]** The freezing base plate 118 is maintained hor-

izontally at an upper position of the ice bin 114 through a plurality of brackets 132, and an evaporator 131 led out of the freezing system housed in the machine chamber 112 is disposed zigzag on the upper surface of the freezing base plate 118. Meanwhile, a plurality of freezing fingers 117 protrude downward from the lower surface of the freezing base plate 118, and these freezing fingers 117 are adapted to be dipped in the water to be frozen carried in the water tray 116 during the freezing operation. As heat exchange with the cooling medium in the evaporator 131 is proceeded by operating the freezing system, the freezing fingers 117 are cooled and maintained at a temperature of 0°C or lower to allow ice pieces 121 to grow gradually around the freezing fingers 117, as shown in Fig. 27. Incidentally, the freezing base plate 118 has a plurality of through holes 118a so as to improve heat exchange efficiency as well as to contribute to weight reduction of the ice making machine.

20 (Cam control mechanism)

**[0080]** As shown in Fig. 20, a first cam 150 and a second cam 151 are formed on the rear surface of the cam plate 136 disposed to the actuator motor AM at radially staggered positions. Meanwhile, a seventh switch SW<sub>7</sub> and a ninth switch SW<sub>9</sub> are disposed to the bracket 135 at the positions corresponding to the locations of the first cam 150 and the second cam 151. By the cam actions to be added in accordance with predetermined timings to the rotation of the actuator motor AM, the following motions to be caused by the operation of the actuator motor AM are designed to be controlled:

(1) tilting or resetting of the water tray 116 and stopping it at such postures, as well as, opening of the hot gas valve HV; and

(2) opening and closing of the water valve WV for supplying water to be frozen. More specifically, the first cam 150 and the second cam 151 each assume a form of arcuate ridge having a predetermined radius and protruding in the axial direction, and a lever 152 extending from the seventh switch SW<sub>7</sub> is designed to be abutted against the first cam 150 or spaced therefrom with a predetermined timing. The seventh switch SW<sub>7</sub> is turned on, upon contact of the lever 152 of the seventh switch SW<sub>7</sub> with the first cam 150. The seventh switch SW<sub>7</sub> is connected to a relay X<sub>2</sub> and the actuator motor AM, as shown in the control circuit diagram of Fig. 25, and controls tilting and resetting of the water tray 116 as well as stopping thereof at such postures by the actuator motor AM and also opening of the hot gas valve HV, as will be described later. Incidentally, the timing of actuating the seventh switch SW<sub>7</sub> by the first cam 150 is shown in the timing chart of Fig. 34.

**[0081]** Meanwhile, the lever 153 extending from the ninth switch SW<sub>9</sub> is designed to be brought into contact

with the second cam 151 and to be spaced therefrom in accordance with a predetermined timing. The ninth switch SW<sub>9</sub> is designed to be turned on upon contact of the lever 153 thereof with the second cam 151. As shown in Fig. 25, the ninth switch SW<sub>9</sub> is connected to the water valve WV to control opening thereof (as will be described later). The timing of the cam actions to be effected by the second cam 151 and the ninth switch is as shown in the timing chart of Fig. 34.

(Rocking plate and rocking mechanism)

**[0082]** A rocking plate 154 is disposed in the freezing chamber 129 defined in the water tray 116 in such a way that it can be rocked freely therein. The rocking plate 154 has a rectangular bottom plate 154a and side walls 154b, 154c, 154d standing upright from the three side edges of the bottom plate 154a, except for the side edge opposing to the left wall 116d, which is to assume the lowest position when the water tray 116 is tilted and is designed to be rocked by the rotation of the rocking motor RM. A multiplicity of circular and/or square through holes 155 are defined at predetermined intervals on the bottom plate 154a and the right side wall 154b of the rocking plate 154. The circumferential size of the rocking plate 154 is designed to be slightly smaller than the inner circumferential size of the bottom 116a of the freezing chamber 129, and a pair of outward protrusions 156 formed on each longitudinal side of the side wall 154b are pivotally supported on the water tray 116 by a pair of pins 157. With the rocking plate 154 pivotally supported in the water tray 116, the rocking plate 154 is brought into intimate contact with the bottom of the freezing chamber 129, as shown in Fig. 19. Incidentally, the positions of the through holes 155 formed on the bottom plate 154a are designed to locate between every two adjacent freezing fingers 117.

**[0083]** As shown in Fig. 16, an inverted L-shaped engagement piece 158 is integrally formed with the front side wall 154c of the rocking plate 154, and the upper horizontal portion 158a thereof extends outward beyond the wall 116b of the freezing chamber 129. Meanwhile, a vertically elongated opening 127a is defined in the inner cover 127 at the position corresponding to the location of the upper horizontal portion 158a, in which a rocking member 159 rotated by the rocking motor RM is slidably fitted. A rocking protrusion 159a is eccentrically formed on the rear side of the rocking member 159, which is designed to be engageable, on the rear side of the inner cover 127, with the lower surface of the upper horizontal portion 158a of the rocking plate 154. Accordingly, the rocking protrusion 159a is rotated under engagement with the upper horizontal portion 158a, as shown in Fig. 26, by rotating the rocking member 159 counterclockwise, to lift the rocking plate 154 to a predetermined height from the bottom of the freezing chamber 129, whereas upon disengagement of the rocking protrusion 159a from the upper horizontal surface 158a,

to allow the rocking plate 154 to drop by its own weight onto the bottom of the freezing chamber 129. Namely, by rotating the rocking motor RM during the freezing operation, the rocking plate 154 repeats such rocking motion in the freezing chamber 129 on the pins 157, whereby the water to be frozen can constantly be agitated. Incidentally, since the rocking plate 154 has through holes 155, the water to be frozen flows through these through holes 155 upward and downward, whereby agitation of the water to be frozen can further be accelerated.

**[0084]** While the rocking plate 154 is tilted as the water tray 116 is tilted upon switching to the ice releasing operation to be described later, a vertical member 160 extending upward over the height of the freezing base plate 118 is formed on the upper edge of the right side wall 154b of the rocking plate 154. By allowing the vertical member 60 to engage with the freezing base plate 118 on the way that the rocking plate 154 is tilted together with the water tray 116, the rocking plate 154 can be separated from the water tray 116 and can assume a fixed tilted posture as such (see Fig. 30).

(Fitting structure of rocking motor RM)

**[0085]** As shown in Figs. 16 and 20, one end portion of the planar fixture 138 is pivotally fitted on the bearing 134 protruding from the inner cover 127, and the rocking motor RM is disposed onto the front surface of the fixture 138 at a position spaced from the pivotally fitted portion thereof. The rocking motor RM is connected to the cam 159b protruding forward from the rocking member 159 through the through hole 127a. Meanwhile, a vertical member 138a is formed on the front side of the fixture 138 at a position between the pivotally fitted portion thereof and the rocking motor RM, and one end portion 139a of the torsion spring 139 is engaged with the lower end of the vertical member 138a. The engagement piece 133e formed on the lever 133b locates adjacent to the vertical member 138a, and the other end portion 139b of the torsion spring 139 is engaged with the upper end of the engagement piece 133e. In the state where the water tray 116 is maintaining the horizontal posture, the upper end of the engagement piece 133e extends upward over the upper end of the vertical member 138a of the fixture 138, as shown in Fig. 26. Accordingly, in this state, the fixture 138 is constantly urged to turn clockwise on the bearing 134 under the resilient action of the torsion spring 139. Upon application of a predetermined external force to the rocking motor RM, the fixture 138 is designed to be pivoted by a predetermined angle on the bearing 134.

**[0086]** Namely, the torsion spring 139 functions to maintain the rocking protrusion 159a of the rocking member 159 at the operational position where it can be engaged with the engagement piece 158 of the rocking plate 154 while the water tray 116 is assuming a horizontal posture during the freezing operation. Mean-

while, when the water tray 116 is tilted upon switching from the freezing operation to the ice releasing operation, the upper end of the engagement piece 133e of the lever 133b is shifted to a position lower than the upper end of the vertical member 138a of the fixture 138, and the end portion 139b of the torsion spring 139 is engaged with the upper end of the vertical member 138a (see Fig. 33). Accordingly, the torsion spring 139 is adapted not to urge the fixture 138 while the water tray 116 is tilted.

**[0087]** Incidentally, a vertical slot 138b is defined in the fixture 138 at the distal end portion spaced from the pivotally supported portion thereof, and a regulating pin 161 provided on the inner cover 127 at the corresponding position is slidably fitted therein. The regulating pin 61 functions to regulate the pivoting range of the fixture 138 so that the lower extremity of the slot 138b may be normally abutted against the regulating pin 161 under the resilient action of the torsion spring 139 to allow the rocking member 159 to be in the operational position (see Fig. 26)

(Switch SW<sub>10</sub> for detecting completion of ice formation and switch Th<sub>1</sub> for detecting completion of ice releasing operation)

**[0088]** A tenth switch SW<sub>10</sub> such as a microswitch for detecting completion of ice formation is disposed on the inner cover 127 through a bracket 170 with the lever 162 of the switch SW<sub>10</sub> being on the descending orbit of the cam 159b of the rocking member 159 so as to be able to be abutted against the cam 159b as the fixture 138 (rocking motor RM) is pivoted and operate the switch SW<sub>10</sub>. Namely, as will be described later referring to Fig. 27, when ice pieces 121 are formed around the freezing fingers 117 as the freezing operation proceeds, the rocking plate 154 is brought into contact with these ice pieces 121 in its upward stroke to exert a downward counterforce to the rocking motor RM through the engagement piece 158 and the rocking protrusion 159a. Accordingly, the fixture 138 having mounted thereon the rocking motor RM is pivoted counterclockwise on the bearing 134 and allows the cam 159b to depress the lever 162 of the tenth switch SW<sub>10</sub> in its pivoting process to change over the tenth switch SW<sub>10</sub> from the contact "a" to the contact "b", and thus completion of ice formation is detected. Incidentally, since the bracket 170 is disposed to the inner cover 127 to be adjustable in the vertical direction, the position of the lever 162 of the tenth switch SW<sub>10</sub> can be adjusted by adjusting vertically the position of the bracket 170. Thus, the size of the ice pieces 121 to be formed around the freezing fingers 117 can be changed.

**[0089]** It should be noted here that, if the rocking motor RM is stopped upon changing over of the tenth switch SW<sub>10</sub> to the contact "b", the rocking protrusion 159a abutted against the engagement piece 158 of the rocking plate 154 interferes with the tilting motion of the rock-

ing plate 154. Therefore, in the second embodiment, a notch 159c is formed on the cam 159b of the rocking member 159, which can change over the tenth switch SW<sub>10</sub> to the contact "a" with the rocking motor RM being pivoted downward whereby to control the rocking protrusion 159a to deviate from the tilting orbit of the engagement piece 158. Meanwhile, this notch 159c is defined on the cam 159b in a positional relationship such that it may locate at a position corresponding to that of the lever 162 of the tenth switch SW<sub>10</sub> when the rocking protrusion 159a is spaced from the upper horizontal portion 158a of the engagement piece 158. In other words, the motor RM is designed:

(1) to be rotated still after changing over of the tenth switch SW<sub>10</sub> for detecting completion of ice formation to the contact "b" by the pivoting of the rocking motor RM; and

(2) to be stopped when the notch 159c is brought to the position corresponding to the location of the lever 162 of the switch SW<sub>10</sub> to change over the switch SW<sub>10</sub> to the contact "a". Thus, the rocking protrusion 159a is deviated from the tilting orbit of the engagement piece 158 of the rocking plate 154 and thus does not interfere with the tilting motion of the rocking plate 154.

**[0090]** As shown in Fig. 19, a thermometal switch Th<sub>1</sub> for detecting completion of the ice releasing operation is disposed on the upper surface of the freezing base plate 118 in the freezing unit 115. This thermometal switch Th<sub>1</sub> is designed to be changed over to the contact "b" upon dropping of the temperature of the freezing base plate 118 to a predetermined level by the freezing operation, or changed back from the contact "b" to the contact "a" upon detection of the sudden temperature rise caused by dropping of the ice pieces 121 from the freezing fingers 117 by the ice releasing operation. Simultaneously, the hot gas valve HV is designed to be closed, as will be described later, and the actuator motor AM is also designed to be rotated.

(Ice discharging unit and ice fullness detection switch)

**[0091]** An ice discharging motor GM is disposed at the front lower position of the inner cover 127, and a screw 163 for carrying the ice pieces to be driven by the motor GM is disposed in the ice chamber 183 to extend therein. The inner end portion of the screw 163 is rotatably fitted in a recess 164 defined at the corresponding position of the ice bin 114, as shown in Fig. 17, so that the screw 163 can be rotated at a fixed position. The the ice discharging motor GM is designed to be rotated only while the push button 125 provided on the front panel 123 is depressed to actuate the sixth switch SW<sub>6</sub> and carry the ice pieces 121 stored in the ice chamber 183 with the aid of the screw 163 to the outlet 114a.

**[0092]** As shown in Fig. 17, a regulating plate 165 is

pivotaly hanging from the rear side of the inner cover 127 at the position corresponding to the location of the screw 163 and inner than the position of the outlet 114a. This regulating plate 165 is designed to be pushed forward by the ice pieces 121 carried by the screw 163 to open the outlet 114a and allow delivery of the ice pieces 121 to the outside of the machine, as well as, to return to the initial position when the ice discharging unit 113 is stopped to close the outlet 114a and prevent the outer air from flowing into the ice chamber 183. Meanwhile, a separator 168 is disposed to the inner cover 127 at a position adjacent to the regulating plate 165, which functions to prevent the ice pieces 121 stored in the ice bin 114 from slipping out of the outlet 114a, as well as, to return some of the ice pieces carried by the screw 163 into the ice chamber 183 and prevent clogging of the outlet 114a thereby. Incidentally, a drain pipe 169 is provided at the bottom of the ice bin 114 adjacent to the recess 164, so that the water melting from the ice pieces 121 can be discharged to the outside of the ice bin 114.

**[0093]** A detection plate 166 is pivotaly supported on the lower surface of the water tray 116, which is normally maintained in such a state that the open end side thereof may be spaced apart downward from the bottom of the water tray 116, as shown in Fig. 22. An eighth switch  $SW_8$  for detecting ice fullness is disposed to the front surface of the water tray 116 with its lever 167 being normally urged by the protrusion 166a formed on the front side of the proximal end portion of the detection plate 166. When the detection plate 166 is abutted against the ice pieces 121 in the process of tilting of the water tray 116 to turn clockwise relative to the water tray 116, the protrusion 166a is designed to be spaced from the lever 167 to turn on the switch  $SW_8$ , and thus ice fullness is detected. Incidentally, the protrusion 166a of the detection plate 166 is adapted to be abutted against the lever 167 of the eighth switch  $SW_8$  under detection of no ice piece 121, so that the ice making machine can be stopped whenever the detection plate 166 happens to drop from the water tray 116 for some reason. Accordingly, no ice piece 121 is adapted to be formed under the condition where ice fullness is not detectable. Meanwhile, the free end portion of the detection plate 166 has a comblike form, whereby the load to be applied to the detection plate 166 when it is abutted against the ice pieces 121 can be reduced.

(Example of electric control circuit)

**[0094]** Fig. 25 shows an electric control circuit in the ice making machine according to the second embodiment, in which a fuse F is interposed between a power supply line R and a joint D, and a power supply indication lamp L is interposed between the joint D and a line T. Likewise, (1) the sixth switch  $SW_6$  for ice discharging and the ice discharging motor GM; (2) the seventh switch  $SW_7$  for the actuator motor AM, the eighth switch  $SW_8$  for detecting ice fullness and a relay  $X_1$  are inter-

posed in series respectively between the joint D and the line T. Meanwhile, a normally closed contact  $X_1-b_1$  for the relay  $X_1$  is interposed between a joint E and a joint K locating between the seventh switch  $SW_7$  and the eighth switch  $SW_8$ . Between the joint K and the line T are interposed in series respectively (1) a relay  $X_2$ ; (2) the ninth switch  $SW_9$  for supplying water to be frozen and the water valve WV; and (3) a normally open contact  $X_3-a_1$  for a relay  $X_3$  and the actuator motor AM.

**[0095]** Meanwhile, a normally closed contact  $X_2-b_1$  for the relay  $X_2$  and a normally closed contact  $X_3-b$  for the relay  $X_3$  are interposed in series between the normally closed contact  $X_1-b_2$  of the relay  $X_1$  connected in series to the fuse F and a joint N locating between the normally open contact  $X_3-a_1$  of the relay  $X_3$  and the actuator motor AM. A fan motor FM for the condenser 111 is connected to the contact "a" of the thermometal switch  $Th_1$  for detecting completion of the ice releasing operation connected in series to the normally open contact  $X_2-a$  of the relay  $x_2$ , while the hot gas valve HV for supplying a hot gas is connected to the contact "b" thereof. Further, between the normally closed contact  $X_1-b_2$  of the relay  $X_1$  and the line T, are interposed in series respectively (1) a normally open contact  $X_3-a_2$  for the relay  $X_3$ , the rocking motor RM and a normally closed contact  $X_2-b_2$  for the relay  $X_2$ ; and (2) a relay SR and the compressor CM. The tenth switch  $SW_{10}$  for detecting completion of ice formation is connected to a joint P locating between the normally open contact  $X_3-a_2$  of the relay  $X_3$  and the rocking motor RM, and a protective thermometal cut-off  $Th_2$  is connected to the contact "a" of the switch  $SW_{10}$ , while the contact "b" thereof is connected to the joint D. Incidentally, the fan motor FM and the relay  $X_3$  are connected in parallel.

**[0096]** Next, the actions of the ice making machine employing the cam control mechanism according to the second embodiment of the invention will be described referring to the timing chart shown in Fig. 34.

(Initial operation)

**[0097]** Upon actuation of a power switch (not shown) of the ice making machine, the power supply indication lamp L is lit, and the compressor CM is also started to supply the cooling medium to the evaporator 131. Meanwhile, the actuator motor AM is rotated through the normally closed contacts  $X_1-b_2$ ,  $X_2-b_1$  and  $X_3-b$  of the relays  $X_1$ ,  $X_2$  and  $X_3$ , respectively, so that the water tray 116 assuming the horizontal posture starts tilting downward. The seventh switch  $SW_7$  is turned on after the ninth switch  $SW_9$  is turned off by the rotation of the motor AM, whereby the relay  $X_2$  is actuated to close the normally open contact  $X_2-a$  which interlocks therewith and actuate the relay  $X_3$  through the thermometal switch  $Th_1$ . Thus, the actuator motor AM is allowed to continue its rotation through the normally open contact  $X_3-a_1$  which interlocks with the relay  $X_3$ , in turn, to reset the water tray 116 to the horizontal posture without stopping in the

tilted posture. Incidentally, the relay  $X_3$  is self-held by the normally open contact  $X_{3-a_2}$  which interlocks therewith.

**[0098]** Upon resetting of the water tray 116 to a predetermined position, the ninth switch  $SW_9$  is turned on to open the water valve  $WV$ , and water is supplied to the freezing chamber 129 defined in the water tray 116 through the water supply pipe 149. Since the water tray 116 is designed to be stopped in the horizontal posture after it is turned once clockwise over the horizontal posture such that the wall 116d may be higher than the wall 116e and then counterclockwise, a predetermined amount of water is designed to be carried securely in the freezing chamber 129. If water to be frozen is supplied in an excess amount to the freezing chamber 129, it is adapted to flow over the dam plate 148, as described above and to be discharged to the outside of the machine through the auxiliary chamber 146 and the water collecting section 119.

**[0099]** The rotation of the actuator motor  $AM$  is stopped upon turning off of the seventh switch  $SW_7$  as the motor  $AM$  is rotated, and the water tray 116 is stopped in the horizontal posture. Meanwhile, rotation of the rocking motor  $RM$  is started upon closure of the normally closed contact  $X_{2-b_2}$  which interlocks with the relay  $X_2$ . Upon turning off of the seventh switch  $SW_7$ , the water valve  $WV$  is closed to stop supply of water. However, the ninth switch  $SW_9$  is allowed to hold the ON-state.

(Freezing operation)

**[0100]** A cooling medium is supplied to the evaporator 131 through a circulation pipe of the freezing system by a compressor  $CM$  powered by electricity, and cooling of the freezing fingers 117 provided on the freezing base plate 118 is started by the heat exchange action of the cooling medium. Since the freezing fingers 117 are dipped in the water to be frozen, the water starts to freeze around the freezing fingers 117 and grows gradually into inverted dome-shaped ice pieces 121. During such freezing operation, the rocking motor  $RM$  is continuously rotated. Accordingly, the rocking protrusion 159a of the rocking member 159 rotated by the motor  $RM$  is engaged with the engagement piece 158 provided on the side wall 154c to lift the rocking plate 154, as shown in Fig. 26. Upon disengagement of the rocking protrusion 159a from the engagement piece 158, the rocking plate 154 drops by its own weight and is abutted against the bottom 116a of the freezing chamber 129. Thus, the rocking plate 154 repeats such rocking motion in the water to be frozen in the freezing chamber 129 during the freezing operation to constantly agitate the water. In addition, since through holes 155 are formed on the rocking plate 154, the water to be frozen flows through these through holes 155 as the rocking plate 154 is rocked to cause jet streams which accelerate the agitation of the water to be frozen. Since the water to be

frozen is constantly maintained in a dynamic state, as described above, opacification of ice pieces 121 to be formed around the freezing fingers 117 can be prevented, and thus transparent and clear ice pieces 121 can be formed.

(Ice releasing operation)

**[0101]** As shown in Fig. 27, upon formation of inverted dome-like ice pieces 121 fully around the freezing fingers 117, the rocking plate 154 is brought into contact with the ice pieces 121 in its upward stroke and finally exerts a downward counterforce to the rocking motor  $RM$  through the engagement piece 158 and the rocking protrusion 159a. Accordingly, the fixture 138 having mounted thereon the rocking motor  $RM$  starts to make a counterclockwise turn on the bearing 134 to allow the cam 159b of the rocking member 159 to depress the lever 162 of the tenth switch  $SW_{10}$  for detecting completion of ice formation to be changed over from the contact "a" to the contact "b", and thus completion of ice formation in the freezing unit 115 is detected. Whereupon the self-hold of the relay  $X_3$  shown in Fig. 25 is released to close the normally closed contact  $X_{3-b}$  which interlocks therewith and start rotation of the actuator motor  $AM$ . Thus, the cam plate 136 is turned counterclockwise to tilt counterclockwise the lever 133b of the pivotal shaft 133 engaged with the connection rod 137 connected eccentrically thereto, and thus the water tray 116 starts to be tilted downward (see Fig. 29). By this tilting motion of the water tray 116, the water remaining in the freezing chamber 129 flows over the dam plate 148 into the auxiliary chamber 146 and then discharged to the water collecting section 119 therefrom. Incidentally, during the process that the water tray 116 is tilted, actuation of the ninth switch  $SW_9$  by the second cam 151 of the cam late 136 rotated by the actuator motor  $AM$  is released (see Fig. 34).

**[0102]** The rocking motor  $RM$  continues to rotate even after the tenth switch  $SW_{10}$  for detecting completion of ice formation is changed over to the contact "b" when the lever 162 thereof is depressed by the cam 159b of the rocking member 159 (because the seventh switch  $SW_7$  is turned off to close the normally closed contact  $X_{2-b_2}$  of the relay  $X_2$ ). Thus, the rocking protrusion 159a provided on the rocking member 159 is spaced from the upper horizontal portion 158a to allow the fixture 138 to turn clockwise under the resilient action of the torsion spring 139, in turn, to change over the tenth switch  $SW_{10}$  from the contact "b" to the contact "a" and stop temporarily the rocking motor  $RM$ . Accordingly, the upper end of the engagement piece 133e of the lever 133b is shifted to a position lower than the upper end of the vertical member 138a formed on the fixture 138 to allow the end 139b of the torsion spring 139 to be engaged with the upper end of the vertical member 138a, where the torsion spring 139 exerts no resilient action to the fixture 138 (see Fig. 33(b)). Whereupon, the fixture 38 starts to

turn counterclockwise on the bearing 134 by its own weight to allow the cam 159b to change over the tenth switch SW<sub>10</sub> from the contact "a" to the contact "b" and start the rocking motor RM. The depression of the lever 162 is released when the notch 159c formed on the cam 159a comes to the position corresponding to the location of the lever 162 to change over the switch SW<sub>10</sub> from the contact "b" to the contact "a" and stop rotation of the rocking motor RM (see Fig. 33 (c)). Thus, the rocking protrusion 159a provided on the rocking member 159 stops at a position deviated from the tilting orbit of the engagement piece 158 of the rocking plate 154, where it does not interfere with the tilting motion of the rocking plate 154.

**[0103]** Upon arrival of the first cam 150 provided on the cam plate 136 to the lever 152 of the seventh switch SW<sub>7</sub>, the switch SW<sub>7</sub> is turned on to actuate the relay X<sub>2</sub> and to open the normally closed contact X<sub>2</sub>-b<sub>1</sub> which interlocks therewith, as well as, to close the normally open contact X<sub>2</sub>-a. In this state, the thermometal switch Th<sub>1</sub> for detecting completion of the ice releasing operation is connected to the contact "b", since ice pieces 121 are formed fully around the freezing fingers 127. Accordingly, the relay X<sub>3</sub> is not actuated, and the rotation of the actuator motor AM is stopped to allow the water tray 116 to stop in a tilted posture at a predetermined angle, as shown in Fig. 30. In this state, while a portion of the water to be frozen remains in the freezing chamber 129 due to the presence of the dam plate 148, such residual water, fully cooled during the previous freezing operation, is mixed with another portion of water to be supplied afresh to cool effectively the thus combined water to be frozen. Meanwhile, the ice pieces 121 formed around the freezing fingers 117 are exposed as such by tilting the water tray 116. Further, in the process that the water tray 116 is tilted and stopped in the tilted posture, the vertical member 160 of the rocking plate 154 is abutted against the freezing base plate 118, so that the rocking plate 154 is allowed to locate diagonally above the bottom 116a of the freezing chamber 129 in the water tray 116 which stops later in the tilted posture. The rocking plate 154 also functions as a chute for guiding the ice pieces 121 dropping from the freezing fingers 117 into the ice chamber 183.

**[0104]** Simultaneously with the stopping of the actuator motor AM, the hot gas valve HV is opened to supply a hot gas, instead of the cooling medium, to the evaporator 131, as shown in the timing chart of Fig. 34, so that the freezing fingers 117 are rapidly heated through the freezing base plate 118. Accordingly, the bondage between the freezing fingers 117 and the ice pieces 121 is released, and the ice pieces 121 drop by their own weights, slide on the upper surface of the rocking plate 154 maintained in a predetermined tilted posture by the vertical member 160 and are guided into the ice chamber 183.

**[0105]** The negative temperature load applied to the freezing base plate 118 is released by the dropping of

the ice pieces 121, and the temperature of the freezing base plate 118 is suddenly elevated by the passage the hot gas through the evaporator 131. This temperature rise is detected by the thermometal switch Th<sub>1</sub>, which is immediately changed over to the contact "a" to actuate the relay X<sub>3</sub>, in turn, to close the normally open contact X<sub>3</sub>-a<sub>1</sub> which interlocks therewith and allows the actuator motor AM to resume rotation. Meanwhile, the hot gas valve HV is also closed to resume supplying of the cooling medium to the evaporator 131.

**[0106]** The pivotal shaft 133 is turned clockwise under the actions of the cam plate 136, connection rod 137 and lever 133b by this rotation of the motor AM, and the water tray 116 is likewise turned clockwise to start resetting to the horizontal posture. Meanwhile, the second cam 151 of the cam plate 136 comes to the lever 153 of the ninth switch SW<sub>9</sub> as the motor AM resumes rotation to turn on the switch SW<sub>9</sub>, as shown in Fig. 31, whereby the water valve WV is opened to supply water to be frozen to the freezing chamber 129 again.

**[0107]** Upon disengagement of the first cam 150 of the cam plate 136 from the lever 152 of the seventh switch SW<sub>7</sub>, actuation of the switch SW<sub>7</sub> is released to close the water valve WV and stop supplying of water to be frozen as well as to stop the actuator motor AM. This is because the relay X<sub>3</sub> is self-held to open the normally closed contact X<sub>3</sub>-b thereof. Thus, the water tray 116 is stopped in the horizontal posture.

**[0108]** Incidentally, in the second embodiment, resetting of the water tray 116 to the horizontal posture is designed to be carried out by turning once the water tray 116 clockwise over the horizontal posture such that the free end portion thereof (the wall 116d side) may be higher than the fixed end portion thereof and then turning counterclockwise to stop in the horizontal posture, as shown in Fig. 32. Namely, if water to be frozen is supplied in a sufficient amount to the freezing chamber 129 with the dam plate 148 provided in the water tray 116 locating at a high level to let the water to flow over the dam plate 148, a necessary amount of water to be frozen is adapted to be securely supplied to the freezing chamber 129 when the water tray 116 is reset to the horizontal posture. Thus, possible troubles to be caused by the lack of water to be frozen can be prevented.

**[0109]** Meanwhile, as the pivotal shaft 133 is turned clockwise, the upper end of the engagement piece 133e of the lever 133b shifts upward to a position higher than the upper end of the vertical member 138a of the fixture 138, so that the end portion 139b of the torsion spring 139 is engaged with the upper end of the engagement piece 133e (see Fig. 33(a)). Thus, the fixture 138 is turned clockwise on the pivotal shaft 133 by the resilience of the torsion spring 139, to allow the rocking protrusion 159a of the rocking member 159 to be in the operational position where it can be engaged with the engagement piece 158 of the rocking plate 154. Accordingly, upon releasing actuation of the relay X<sub>2</sub> by the turning off of the seventh switch SW<sub>7</sub>, the normally

closed contact  $X_2-b_2$  which interlocks therewith is closed to rotate the rocking motor RM and allow the rocking plate 154 to resume and continue the rocking motion during the freezing operation.

**[0110]** When the water tray 116 is tilted after completion of the freezing operation with a predetermined amount of ice pieces 121 being stored in the ice chamber 183 by repeating the freezing operation and the ice releasing operation, the detection plate 166 is abutted against the group of ice pieces in the tilting process thereof, and it is prevented thereby from tilting further. Thus, the detection plate 166 is turned clockwise relative to the water tray 116 to turn on the eighth switch  $SW_8$  for detecting ice fullness. In this state, the seventh switch  $SW_7$  shown in Fig. 25 is turned on to actuate the relay  $X_1$ , whereby the normally closed contacts  $X_1-b_1$  and  $X_1-b_2$  are opened to stop rotation of the actuator motor as well as to stop energization of the compressor CM.

**[0111]** Incidentally, in the illustrated embodiments of the invention, while the freezing fingers 36,117 extending at predetermined intervals from the lower surface of the freezing base plate 34,118 are tapered downward, the shape of the freezing fingers 36,117 may not be limited thereto, and various modifications such as round bars, pins, etc. can suitably be employed, so long as they function as, as it were, nuclear freezing members.

## Claims

### 1. An ice making machine having:

an evaporator (22, 131) connected to a freezing system including a compressor (CM) and condenser (18, 111);

a freezing base plate (34, 118) having a multiplicity of freezing fingers (36, 117) formed on the lower surface thereof, with said evaporator (22, 131) being disposed on the upper surface thereof;

a water tray (24, 116) pivotally supported to maintain normally a horizontal posture and having defined therein a freezing chamber (32, 129), for carrying water to be frozen in which said freezing fingers (36, 117) are to be dipped; said water tray (24, 116) being adapted to be tilted downward upon freezing of the water to form ice pieces (70, 121) around the freezing fingers (36, 117) and after releasing of the ice pieces (70, 121), to be reset to the horizontal posture;

an actuator motor (AM) for tilting and resetting said water tray (24, 116);

a rotatable control cam (13, 150); and

a control switch ( $SW_1$ ,  $SW_7$ ) disposed on the fixed side corresponding to the location of said control cam (13, 150) for giving a cam action in

accordance with a predetermined timing; said control cam (13, 150) being directly connected to said actuator motor (AM), wherein rotation of said actuator motor (AM) causes rotation of said control cam (13, 150), whereby said control switch ( $SW_1$ ,  $SW_7$ ) is actuated to control tilting of said water tray (24, 116) and resetting thereof in the horizontal posture, and stopping of the water tray at such tilted and horizontal postures,

characterized by :

a second rotatable cam (17, 151) directly connected to said actuator motor (AM); and a second switch ( $SW_3$ ,  $SW_9$ ) disposed on the fixed side corresponding to the location of said second cam (17, 151) to give cam actions in accordance with a predetermined timing under rotation of said actuator motor (AM); wherein said second cam (17, 151) and said second switch ( $SW_3$ ,  $SW_9$ ) are arranged to control the opening of a water valve (WV) for replenishing water to be frozen in said freezing chamber (32, 129) during the resetting motion of the water tray (24, 116).

### 2. The ice making machine according to claim 1, comprising: a first cam (13) being said control cam, the second cam (17) and a third cam (15) coaxially disposed at predetermined intervals to the rotary shaft of the actuator motor (AM); and

a first switch ( $SW_1$ ) being said control switch, the second switch ( $SW_3$ ) and a third switch ( $SW_2$ ) disposed on the fixed side corresponding to the location of said first, second and third cams (13, 15, 17) for giving cam actions with the rotation of said actuator motor (AM), respectively, in accordance with a predetermined timing;

wherein said third cam (15) and said third switch ( $SW_2$ ) are adapted to control opening and closing of a hot gas valve (HV) for supplying a hot gas to said evaporator (22) during the ice releasing operation.

### 3. The ice making machine according to claim 1, comprising: a cam plate (136) having formed thereon said control cam (150) and said second cam (151) and disposed on the rotary shaft of said actuator motor (AM); wherein said control switch ( $SW_7$ ) and said second switch ( $SW_9$ ) are disposed on the fixed side corresponding to the location of said control cam (150) and said second cam (151) to give cam actions respectively in accordance with a predetermined timing under rotation of said actuator motor (AM).

4. The ice making machine according to claim 1 or 2, comprising:

a rocking plate (44) disposed in said freezing chamber (32) so as to be able to be rocked therein;

a rocking motor (RM) disposed at a position outside said water tray (24), which is vertically slidable;

a detection switch (SW<sub>4</sub>) for detecting completion of ice formation, located on the shifting orbit of said rocking motor (RM); a first engagement means (62) provided on said rocking motor (RM); and

a second engagement means (61) provided on said rocking plate (44) which is engageable with said first engagement means (62); wherein tilting of said water tray (24) is designed to be started by driving the actuator motor (AM) upon detection of completion of ice formation around said freezing fingers (36) by actuation of said detection switch (SW<sub>4</sub>) which is actuated by the shifting of said rocking motor (RM) in a predetermined direction, when said rocking plate (44) is brought into contact with the ice pieces (70) formed around said freezing fingers (36) in the rocking motion of said rocking plate (44) by said rocking motor (RM) through said first and second engagement means (62, 61) to apply a counterforce to said rocking motor (RM), whereby to drive said actuator motor (AM).

5. The ice making machine according to one of claims 1 to 4, wherein the resetting of said water tray (24) is started upon detection by a thermometal switch (Th, Th<sub>1</sub>) for detecting completion of ice releasing operation.

6. The ice making machine according to claim 3, comprising:

pintles (130) formed along the longitudinal side of said water tray (116) orthogonal to the tilting direction thereof and pivotally supported onto the main body of the ice making machine;

a pivotal shaft (133) pivotally supported onto the main body of the ice making machine with one end thereof being fitted to the axial end of said pintle (130) so as to be able to be pivoted integrally therewith, and a lever (133b) extending radially from the other end thereof; and

a connection rod (137) pivotally fitted at one end thereof loosely on a protrusion (133c) and at the other end thereof pivotally supported eccentrically on said cam plate (136);

wherein said pivotal shaft (133) is turned clockwise or counterclockwise through said connection rod (137) by rotating said cam plate (136)

by said actuator motor (AM), whereby to allow said water tray (116) to tilt downward or reset to the horizontal posture.

7. The ice making machine according to claim 3, 6 or 5 when dependent on claim 3, having a duct (147) provided to protrude horizontally from said water tray (116), and a water collecting section (119) defined on the main body of the ice making machine at a position below the tilting orbit of said duct (147); wherein said duct (147) is designed to be abutted against the upper edge of said water collecting section (119), when said water tray (116) is tilted downward, whereby to maintain said water tray (116) in the tilted posture.

### Patentansprüche

1. Eiserzeugungsmaschine mit:

einem Verdampfer (22, 131), der mit einem Gefriersystem mit einem Kompressor (CM) und einem Kondensator (18, 111) verbunden ist;

einer Gefrierbasisplatte (34, 118) mit einer Vielzahl von auf der unteren Oberfläche davon gebildeten Gefrierfingern (36, 117), wobei der Verdampfer (22, 131) auf der oberen Oberfläche davon vorgesehen ist;

einem schwenkbar gelagerten Wassertrog (24, 116) zum Aufrechterhalten einer normalerweise horizontalen Stellung, in dem eine Gefrierkammer (32, 129) abgegrenzt ist zum Halten von zu gefrierendem Wasser, in das die Gefrierfinger (36, 117) einzutauchen sind;

wobei der Wassertrog (24, 116) dazu ausgelegt ist, daß er nach Gefrieren des Wassers zum Bilden von Eisstücken (70, 121) um die Gefrierfinger (36, 117) nach unten geneigt wird und nach dem Freigeben der Eisstücke (70, 121) in die horizontale Stellung zurückgesetzt wird;

einem Betätigungsmotor (AM) zum Neigen und Zurücksetzen des Wassertroges (24, 116);

einer drehbaren Steuernocke (13, 150) und einem auf der festen Seite entsprechend der Stelle der Steuernocke (13, 150) vorgesehenen Steuerschalter (SW<sub>1</sub>, SW<sub>7</sub>) zum Abgeben einer Nockenwirkung gemäß einer vorbestimmten Zeit;

wobei die Steuernocke (13, 150) direkt mit dem Betätigungsmotor (AM) verbunden ist, worin die Drehung des Betätigungsmotors (AM) die Drehung der Steuernocke (13, 150) bewirkt, wodurch der Steuerschalter (SW<sub>1</sub>, SW<sub>7</sub>) zum Steuern des Neigens des Wassertroges (24, 116) und des Zurücksetzens desselben in die horizontale Stellung und Stoppen des Wassertroges an solch einer geneigten und horizonta-

len Stellung aktiviert wird;

gekennzeichnet durch

eine direkt mit dem Betätigungsmotor (AM) verbundene zweite drehbare Nocke (17, 151) und einen auf der festen Seite entsprechend der Stelle der zweiten Nocke (17, 151) vorgesehenen zweiten Schalter (SW<sub>3</sub>, SW<sub>9</sub>) zum Abgeben einer Nockenwirkung gemäß einer vorbestimmten Zeit unter der Drehung des Betätigungsmotors (AM);  
wodurch die zweite Nocke (17, 151) und der zweite Schalter (SW<sub>3</sub>, SW<sub>9</sub>) angeordnet sind zum Steuern des Öffnens eines Wasserventiles (WV) zum Erneuern des in der Gefrierkammer (32, 129) zu gefrierenden Wassers während der Zurücksetzbewegung des Wassertroges (24, 116).

**2.** Eiserzeugungsmaschine nach Anspruch 1, mit:

einer ersten Nocke (13), die die Steuernocke ist, wobei die zweite Nocke (17) und eine dritte Nocke (15) koaxial an vorbestimmten Abständen an der Drehwelle des Betätigungsmotors (AM) vorgesehen sind; und  
einem ersten Schalter (SW<sub>1</sub>), der der Steuer- schalter ist, wobei der zweite Schalter in (SW<sub>3</sub>) und ein dritter Schalter (SW<sub>2</sub>) auf der festen Seite entsprechend der Stelle der ersten, zweiten bzw. dritten Nocke (13, 15, 17) zum Abgeben von Nockenwirkungen mit der Drehung des Betätigungsmotors (AM) gemäß einer vorbestimmten Zeit vorgesehen sind;  
worin die dritte Nocke (15) und der dritte Schalter (SW<sub>2</sub>) zum Steuern des Öffnens und Schließens eines Ventiles (HV) für heißes Gas zum Liefern eines heißen Gases zu dem Verdampfer (22) während der Eisfreigabetätigkeit ausgelegt sind.

**3.** Eiserzeugungsmaschine nach Anspruch 1, mit:

einer Nockenplatte (136), auf der die Steuernocke (150) und die zweite Nocke (151) gebildet sind und die auf der Drehwelle des Betätigungsmotors (AM) vorgesehen ist;  
worin der Steuerschalter (SW<sub>7</sub>) und der zweite Schalter (SW<sub>9</sub>) auf der festen Seite entsprechend der Stelle der Steuernocke (150) bzw. der zweiten Nocke (151) vorgesehen sind zum Abgeben von Nockenwirkungen gemäß einer vorbestimmten Zeit unter der Drehung des Betätigungsmotors (AM).

**4.** Eiserzeugungsmaschine nach Anspruch 1 oder 2, mit:

einer in der Gefrierkammer (32) so vorgesehene Schwingplatte (44), daß sie darin Schwingen kann;

einem an einer Position außerhalb des Wassertroges (24) vorgesehenen Schwingmotor (RM), der vertikal verschiebbar ist;

einem Erkennungsschalter (SW<sub>4</sub>) zum Erkennen der Beendigung der Eisbildung, der auf dem Verschiebungsumlauf des Schwingmotors (RM) angeordnet ist;

einem auf dem Schwingmotor (RM) vorgesehenen ersten Eingriffsmittel (62); und

einem auf der Schwingplatte (44) vorgesehenen zweiten Eingriffsmittel (61), das in Eingriff mit dem ersten Eingriffsmittel (62) kommen kann;

worin das Neigen des Wassertroges (24) gestartet wird durch Antreiben des Betätigungsmotors (AM) nach Erkennen der Beendigung der Eisbildung um die Gefrierfinger (36) durch Betätigen des Erkennungsschalters (SW<sub>4</sub>), der durch das Verschieben des Schwingmotors (RM) in eine vorbestimmte Richtung betätigt wird, wenn die Schwingplatte (44) in Kontakt mit den um die Gefrierfinger (36) gebrachten Eisstücke (70) während der Schwingbewegung der Schwingplatte (44) durch den Schwingmotor (RM) durch das erste und zweite Eingriffsmittel (62, 61) gebracht wird zum Anlegen einer Gegenkraft an den Schwingmotor (RM), wodurch der Betätigungsmotor (AM) angetrieben wird.

**5.** Eiserzeugungsmaschine nach einem der Ansprüche 1 bis 4, worin das Zurücksetzen des Wassertroges (24) nach der Erkennung durch einen Thermometallschalter (Th, Th<sub>1</sub>) zum Erkennen der Beendigung der Eisfreigabetätigkeit gestartet wird.

**6.** Eiserzeugungsmaschine nach Anspruch 3, mit:

Bolzen (130), die entlang der Längsseite des Wassertroges (116) rechtwinklig zu der Neigungsrichtung davon gebildet sind und schwenkbar auf dem Hauptkörper der Eiserzeugungsmaschine gelagert sind;

einer Schwenkwelle (133), die schwenkbar auf dem Hauptkörper der Eiserzeugungsmaschine gelagert ist, wobei ein Ende davon an das axiale Ende des Bolzens (130) so angepaßt ist, daß sie integral damit geschwenkt wird, und wobei sich ein Hebel (133b) radial von dem anderen Ende davon erstreckt; und

einer Verbindungsstange (137), die schwenkbar an einem Ende davon lose in einem Vorsprung (133c) eingepaßt ist und an dem anderen Ende davon schwenkbar exzentrisch auf der Nockenplatte (136) gelagert ist;

worin die Schwenkwelle (133) im Uhrzeigersinn oder entgegengesetzt dem Uhrzeigersinn durch die Verbindungstange (137) durch Drehen der Nockenplatte (136) durch den Betätigungsmotor (AM) gedreht wird, wodurch dem Wassertrog (116) ermöglicht wird, sich nach unten zu neigen oder in die horizontale Stellung zurückzusetzen.

7. Eiserzeugungsmaschine nach Anspruch 3, 6 oder 5, wenn von Anspruch 3 abhängig, mit einer Leitung (147), die so vorgesehen ist, daß sie horizontal von dem Wassertrog (116) vorsteht, und einem Wassersammelabschnitt (119), der in dem Hauptkörper der Eiserzeugungsmaschine an einer Position unterhalb des Neigungsumlaufes der Leitung (147) abgegrenzt ist;  
worin die Leitung (147) so ausgelegt ist, daß sie gegen die Oberkante des Wassersammelabschnittes (119) stößt, wenn der Wassertrog (116) nach unten geneigt wird, wodurch der Wassertrog (116) in der geneigten Stellung gehalten wird.

## Revendications

1. Machine génératrice de glace, comprenant :

un évaporateur (22, 131) relié à un système frigorifique comprenant un compresseur (CM) et un condenseur (18, 111);

une plaque de base frigorifique (34, 118) sur laquelle est formée, à sa face inférieure, une pluralité des doigts frigorifiques (36, 117), ledit évaporateur (22, 131) étant disposé sur sa surface supérieure;

une cuve de l'eau (24, 116) supportée à pivoter afin de maintenir une position normalement horizontale et comprenant une chambre frigorifique (32, 129) définie à son intérieur à contenir de l'eau à frigorifier, pour y immerger lesdits doigts frigorifiques (36, 117);

ladite cuve de l'eau (24, 116) étant disposée à basculer en bas après la congélation de l'eau afin de former des glaçons (70, 121) autour desdits doigts frigorifiques (36, 117), et à être remise en la position horizontale après le dégagement desdits glaçons (70, 121);

un moteur de manoeuvre (AM) à basculer et remettre ladite cuve de l'eau (24, 116);

une came de commande rotative (13, 150); et un commutateur de commande (SW<sub>1</sub>, SW<sub>7</sub>) disposé sur le côté fixe en correspondance avec l'endroit de ladite came de commande (13, 150) afin d'induire une manoeuvre selon un cycle fixe prédéterminé;

ladite came de commande (13, 150) étant reliée directement audit moteur de manoeuvre

(AM), dans laquelle la rotation dudit moteur de manoeuvre (AM) induit la rotation de ladite came de commande (13, 150) en actionnant ledit commutateur de commande (SW<sub>1</sub>, SW<sub>7</sub>) afin de commander le basculement de ladite cuve de l'eau (24, 116) et sa remise en position horizontale, et en arrêtant ladite cuve de l'eau en ces positions basculée et horizontale,

## caractérisée par :

une deuxième came rotative (17, 151) reliée directement audit moteur de manoeuvre (AM); et un deuxième commutateur (SW<sub>3</sub>, SW<sub>9</sub>) disposé du côté fixe en correspondance avec l'endroit de ladite deuxième came (17, 151) afin d'induire une manoeuvre selon un cycle fixe prédéterminé, à rotation continue dudit moteur de manoeuvre (AM);

dans laquelle ladite deuxième came (17, 151) et ledit deuxième commutateur (SW<sub>3</sub>, SW<sub>9</sub>) sont disposés de façon à commander l'ouverture d'un robinet d'eau (WV) pour remplir de l'eau à frigorifier dans ladite chambre frigorifique (32, 129) au cours du mouvement de remise de ladite cuve de l'eau (24, 116).

2. Machine génératrice de glace selon la revendication 1, comprenant :

une première came (13) étant ladite came de commande, ladite deuxième came (7) et une troisième came (15) étant disposé en arrangement coaxial à des écarts prédéterminés relativement à l'arbre tournant dudit moteur de manoeuvre (AM); et

un premier commutateur (SW<sub>1</sub>) étant ledit commutateur de commande, ledit deuxième commutateur (SW<sub>3</sub>) et un troisième commutateur (SW<sub>2</sub>) disposés du côté correspondant à l'endroit desdites première, deuxième et troisième cames (13, 15, 17) afin d'induire des manoeuvres des cames selon un cycle fixe prédéterminé, à rotation continue dudit moteur de manoeuvre (AM);

dans laquelle ladite troisième came (15) et ledit troisième commutateur (SW<sub>2</sub>) sont disposés de façon à commander l'ouverture et la fermeture d'un robinet de gaz chaud (HV) pour l'alimentation dudit évaporateur (22) en gaz chaud au cours de l'opération de dégagement des glaçons.

3. Machine génératrice de glace selon la revendication 1, comprenant :

un plateau-came (136) sur lequel sont formées lesdites cames de commande (150) et ladite

deuxième came (151), qui est disposé sur l'arbre tournant dudit moteur de manoeuvre (AM); dans laquelle ledit commutateur de commande (SW<sub>7</sub>) et ledit deuxième commutateur (SW<sub>9</sub>) sont disposé du côté correspondant à l'endroit de ladite came de commande (150) et ladite deuxième came (151) afin d'induire des manoeuvres respectives des comes selon un cycle fixe prédéterminé, à rotation continue dudit moteur de manoeuvre (AM).

4. Machine génératrice de glace selon la revendication 1 ou 2, comprenant :

une plaque oscillante (44) disposé dans ladite chambre frigorifique (32) de façon à être capable d'y basculer;

un moteur oscillant (RM) disposé à un endroit en dehors de la cuve de l'eau (24), qui est déplaçable en sens vertical;

un premier moyen de prise (62) prévu sur ledit moteur oscillant (RM);

un deuxième moyen de prise (61) prévu sur ladite plaque oscillante (44), qui est capable d'être mis en prise dans ledit premier moyen de prise (62);

dans laquelle le basculement de ladite cuve de l'eau (24) est conçu de façon qu'il est lancé en commandant ledit moteur de manoeuvre (AM) après la détection de la terminaison complète de la formation de glace autour desdits doigts frigorifiques (36) par l'actionnement dudit commutateur détecteur (SW<sub>4</sub>), qui est commandé par le déplacement dudit moteur oscillant (RM) en une direction prédéterminée quand ladite plaque oscillante (44) est portée en contact avec lesdits glaçons (70) formés autour desdits doigts frigorifiques (36) au mouvement oscillant de ladite plaque oscillante (44) par ledit moteur oscillant (RM) via lesdits premier et deuxième moyen de prise (62, 61) afin d'appliquer une force antagoniste audit moteur oscillant (RM) afin de commander ledit moteur de manoeuvre (AM).

5. Machine génératrice de glace selon une quelconque des revendications 1 à 4, dans laquelle la remise de ladite cuve de l'eau (24) est lancée après la détection, moyennant un commutateur thermométallique (Th, Th<sub>1</sub>), de la terminaison complète de l'opération de dégagement des glaçons.

6. Machine génératrice de glace selon la revendication 3, comprenant :

des tourillons (130) formés le long du côté longitudinal de ladite cuve de l'eau (116) en sens orthogonal à sa direction de basculement et

porté à pivoter sur le corps principal de la machine génératrice de glace;

un arbre de pivotement (133) porté à pivoter sur le corps principal de la machine génératrice de glace, à une de ses extrémités étant ajustée à l'extrémité axiale dudit tourillon (130) de façon à être pivoté de manière intégrale avec la dernière; et

une tige de raccordement (137) ajustée à pivoter à une de ses extrémités, de manière lâche, sur une bosse (133c) et porté à pivoter à son autre extrémité de façon excentrique sur ledit plateau-came (136);

dans laquelle ledit arbre de pivotement (133) est tourné en sens horaire ou en sens inverse horaire via ladite tige de raccordement (137) en tournant ledit plateau-came (136) moyennant ledit moteur de manoeuvre (AM), afin de permettre le basculement de ladite cuve de l'eau (116) en bas ou son remise en position horizontale.

7. Machine génératrice de glace selon la revendication 3 et 6 ou 5 quand elle fait référence à la revendication 3, comprenant un passage (147) disposé de façon à être en saillie, en sens horizontal, de ladite cuve de l'eau (116), et un compartiment accumulateur de l'eau (119) défini sur le corps principal de la machine génératrice de glace à une position au dessous du chemin de basculement dudit passage (147); dans laquelle ledit passage (147) est conçu de façon à porter bien contre l'arête supérieure dudit compartiment collecteur de l'eau (119) quand ladite cuve de l'eau (116) est basculée en bas, en maintenant ladite cuve de l'eau (116) en position basculée.

FIG. 1

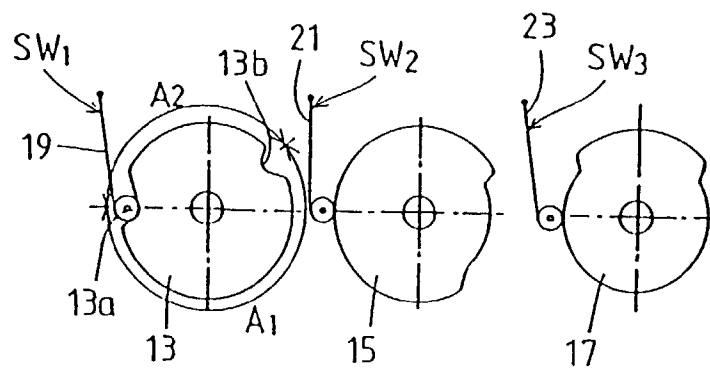
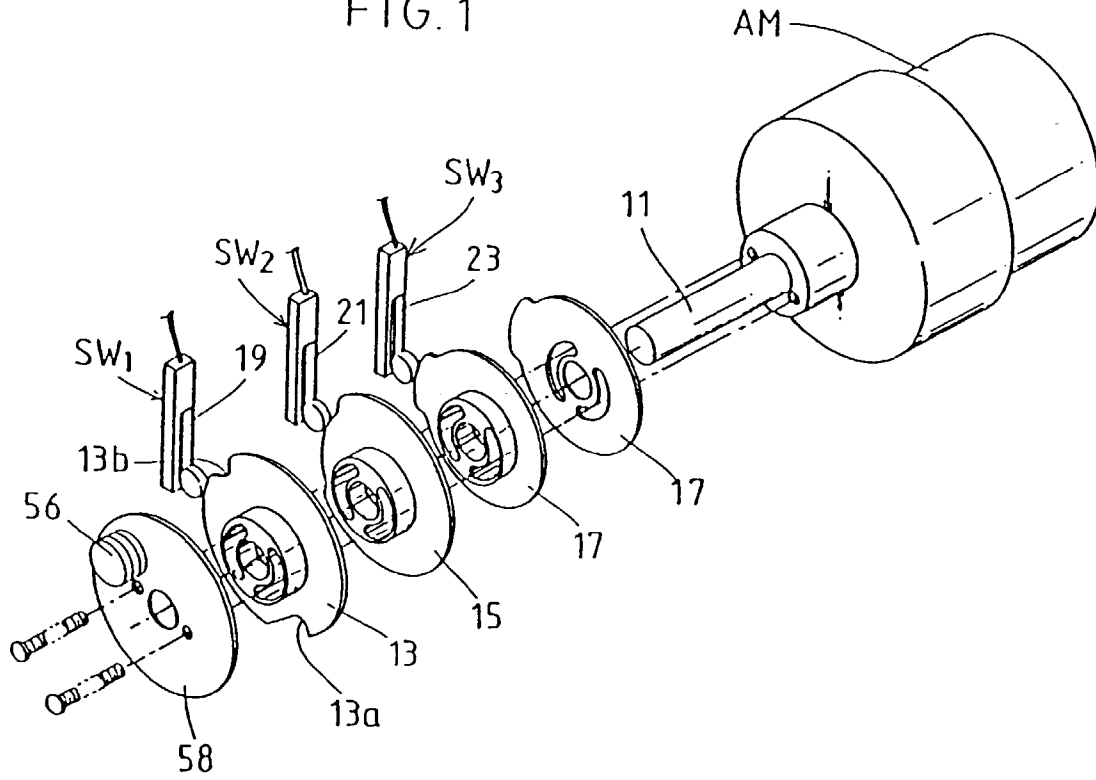
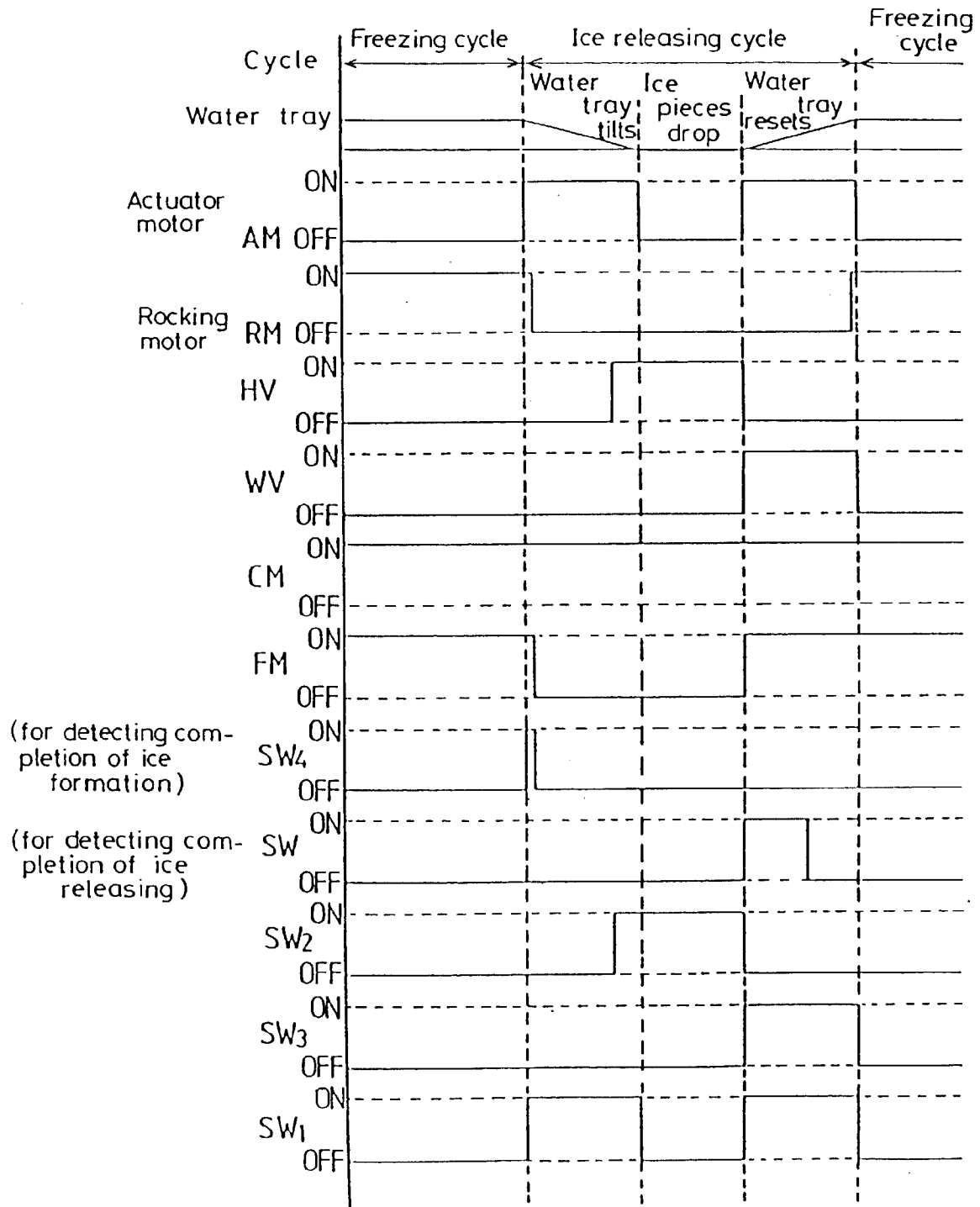



FIG. 3



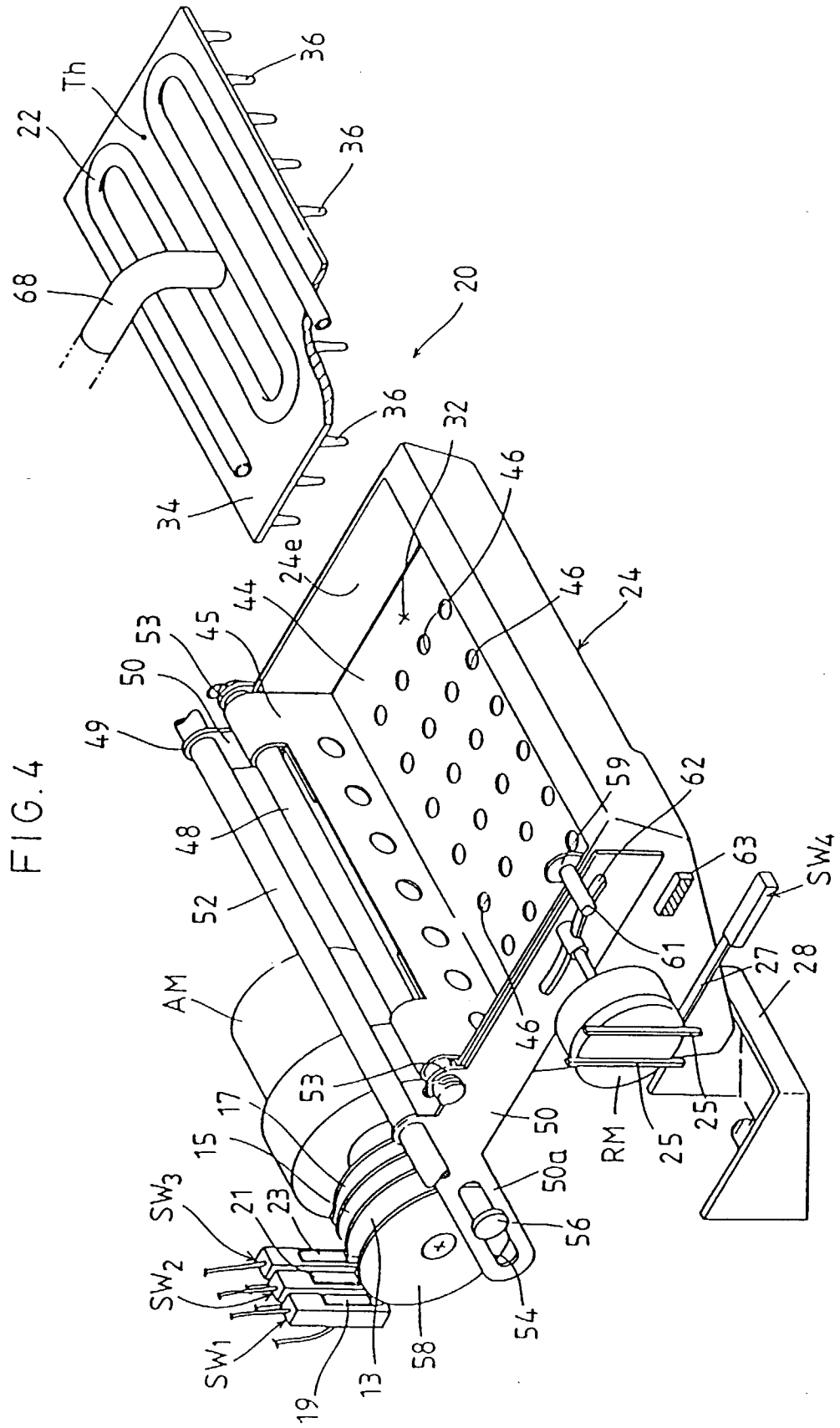

FIG. 5

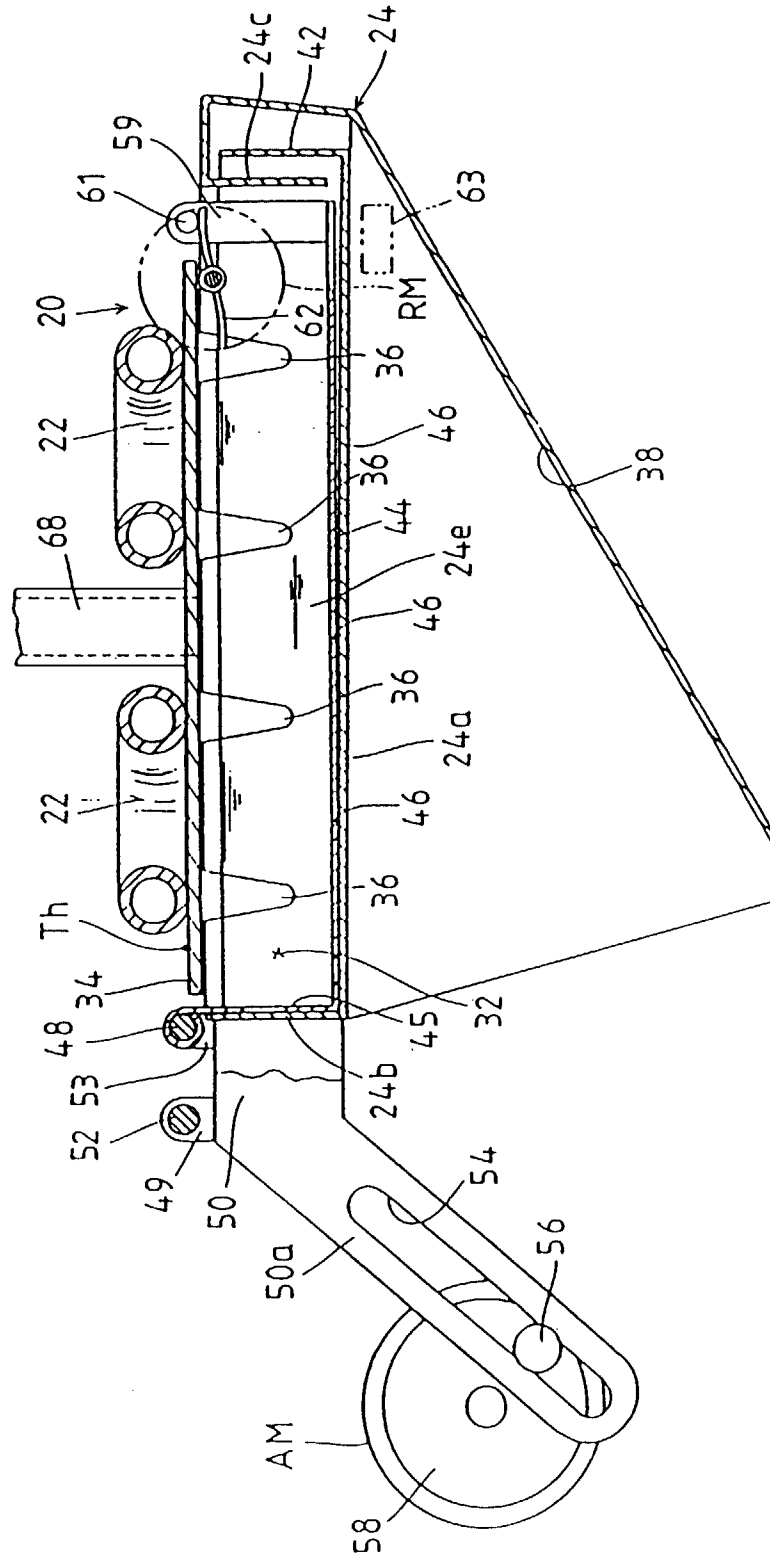

FIG. 6

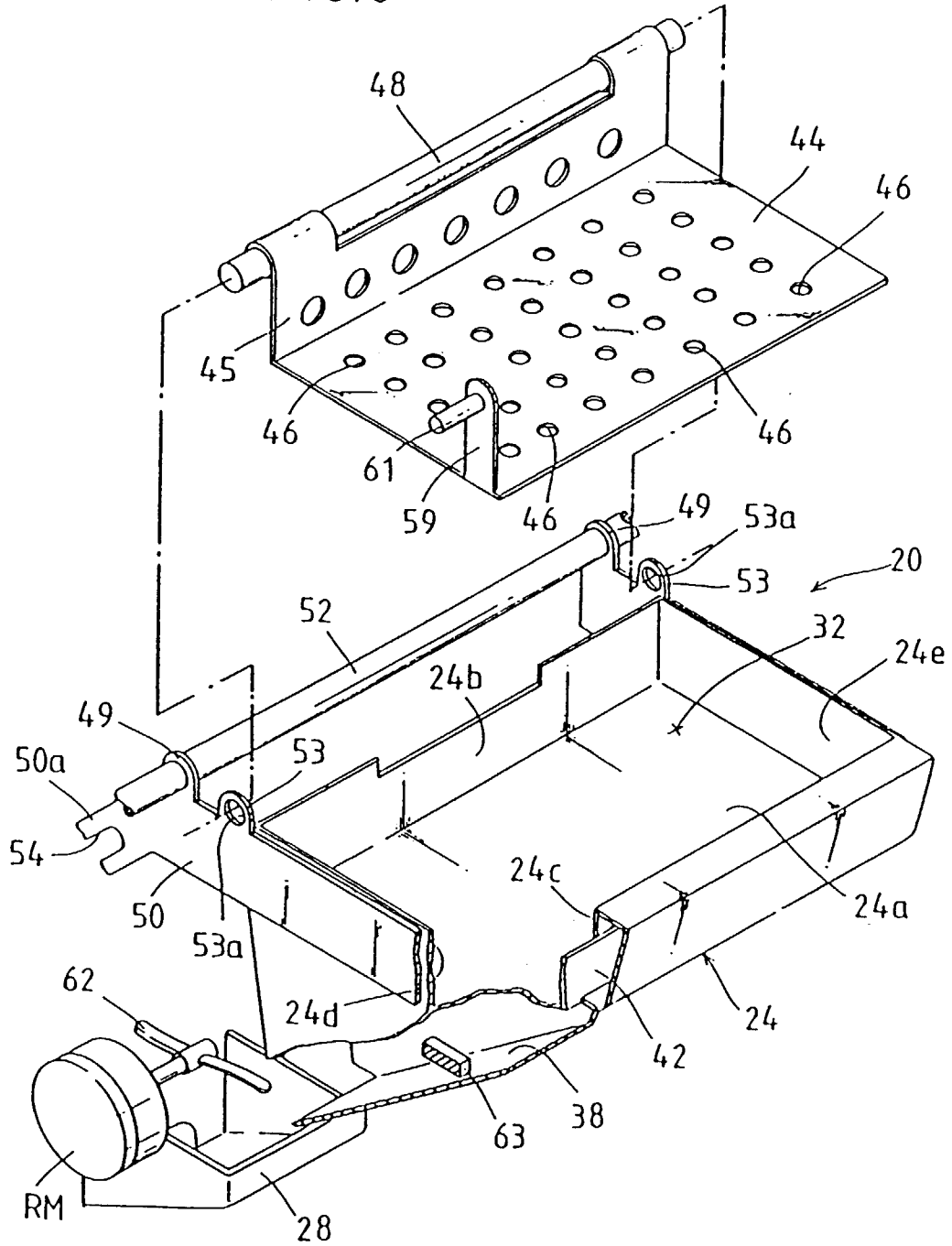

FIG. 7

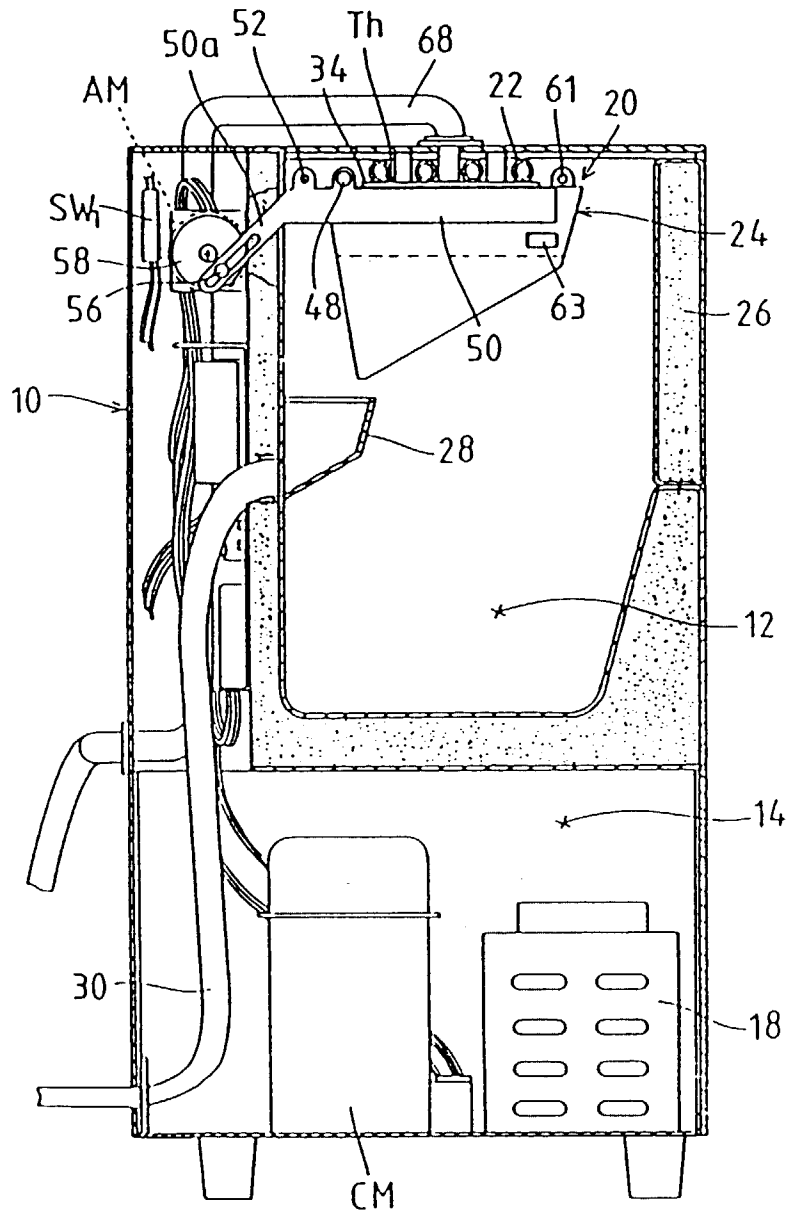

FIG. 8

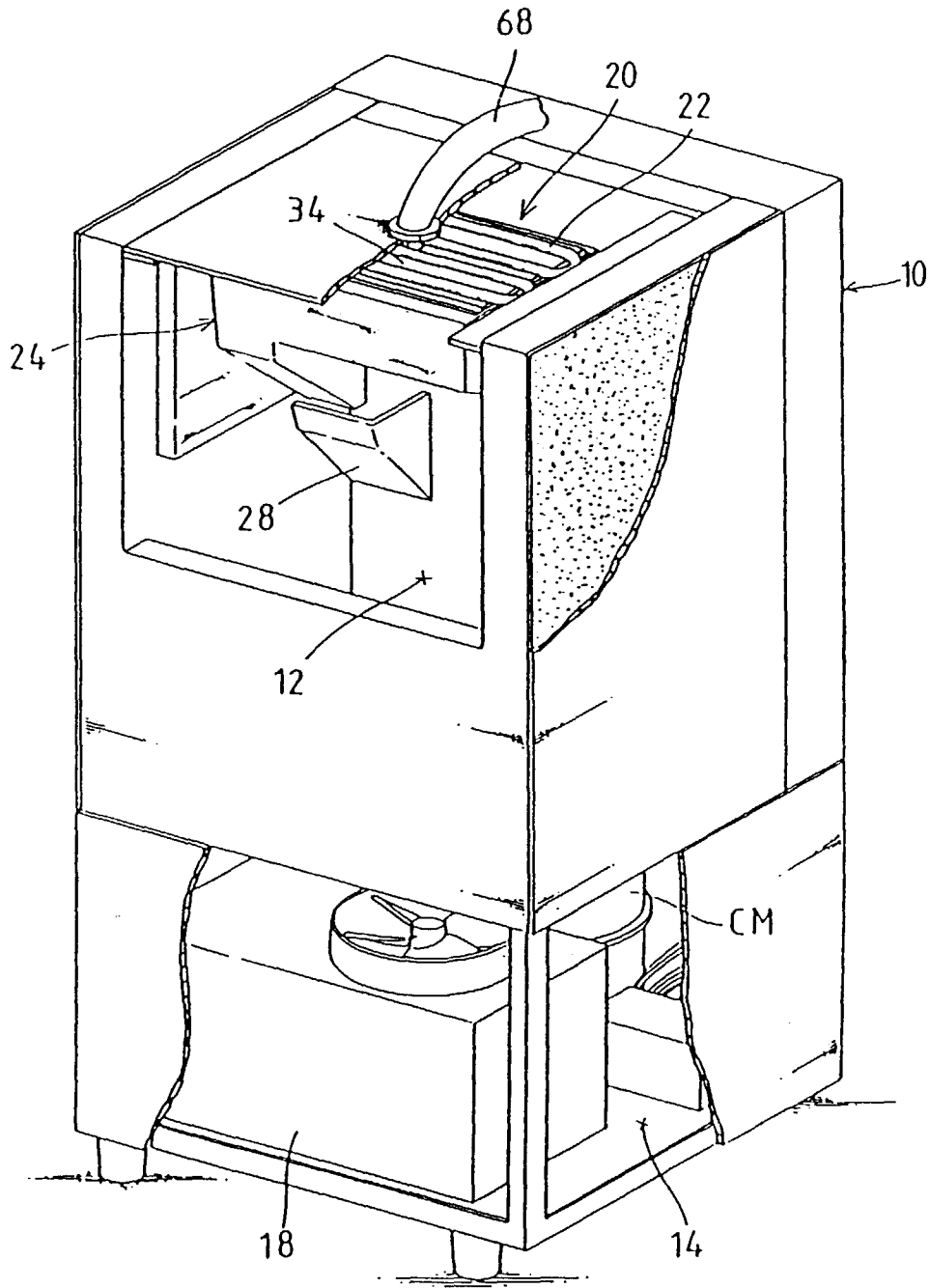

FIG. 9

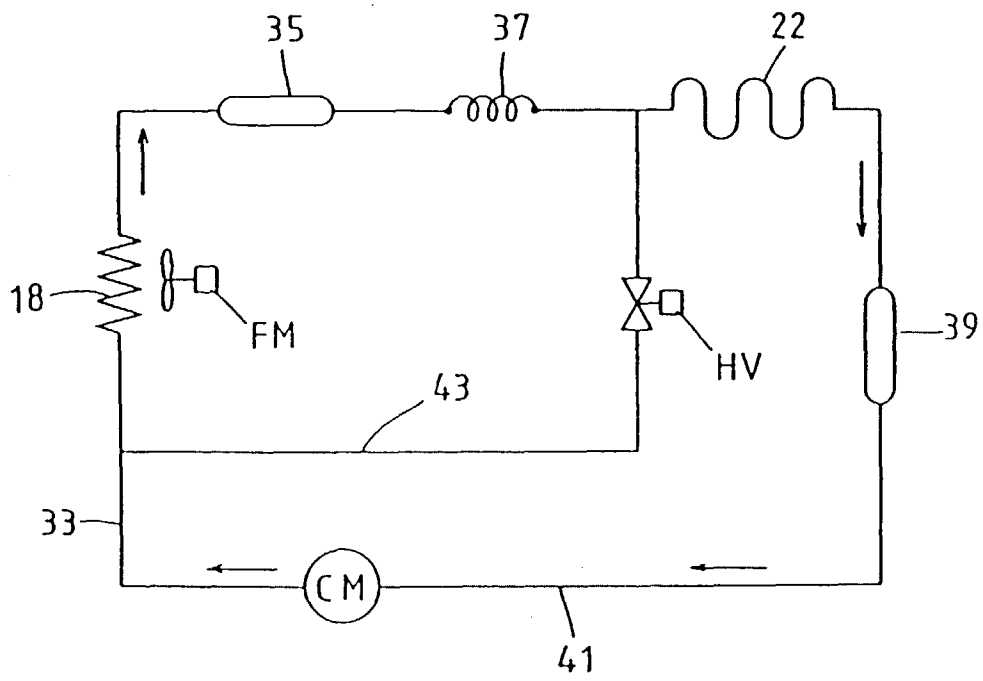

FIG.10

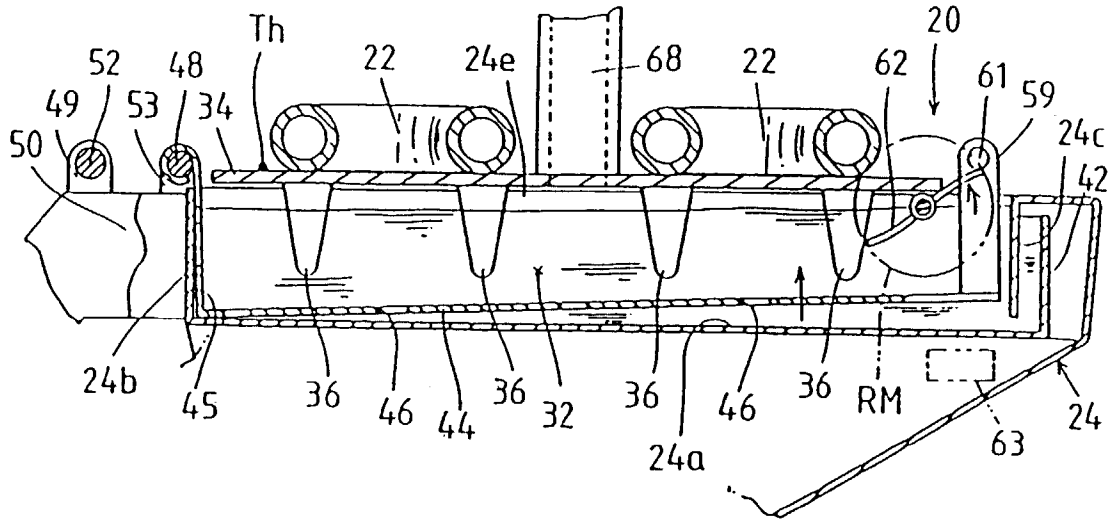

FIG.11

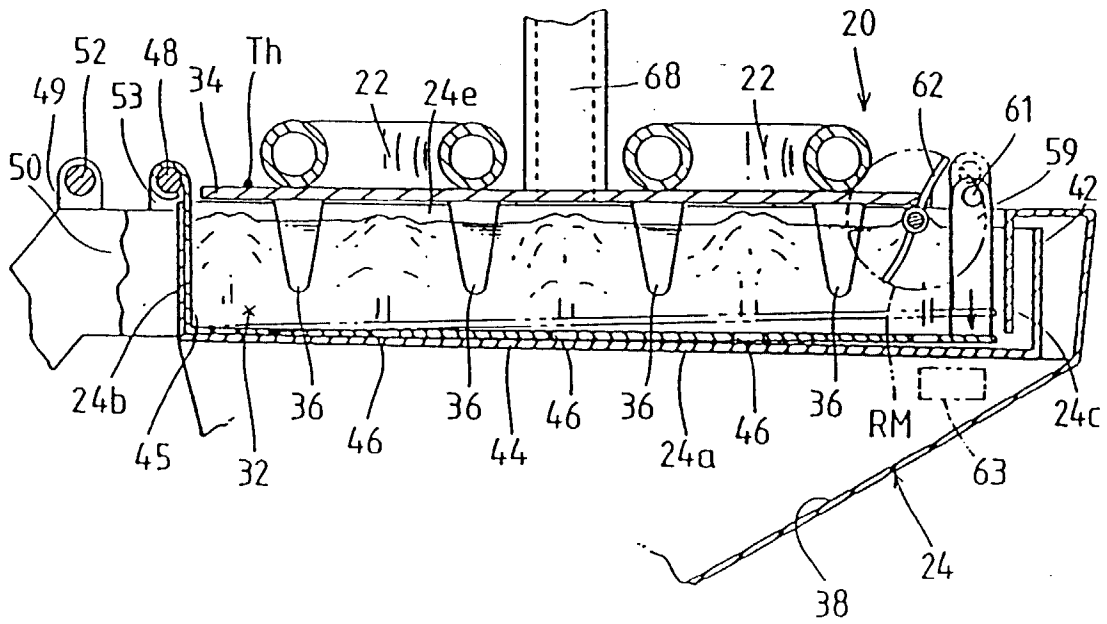

FIG.12

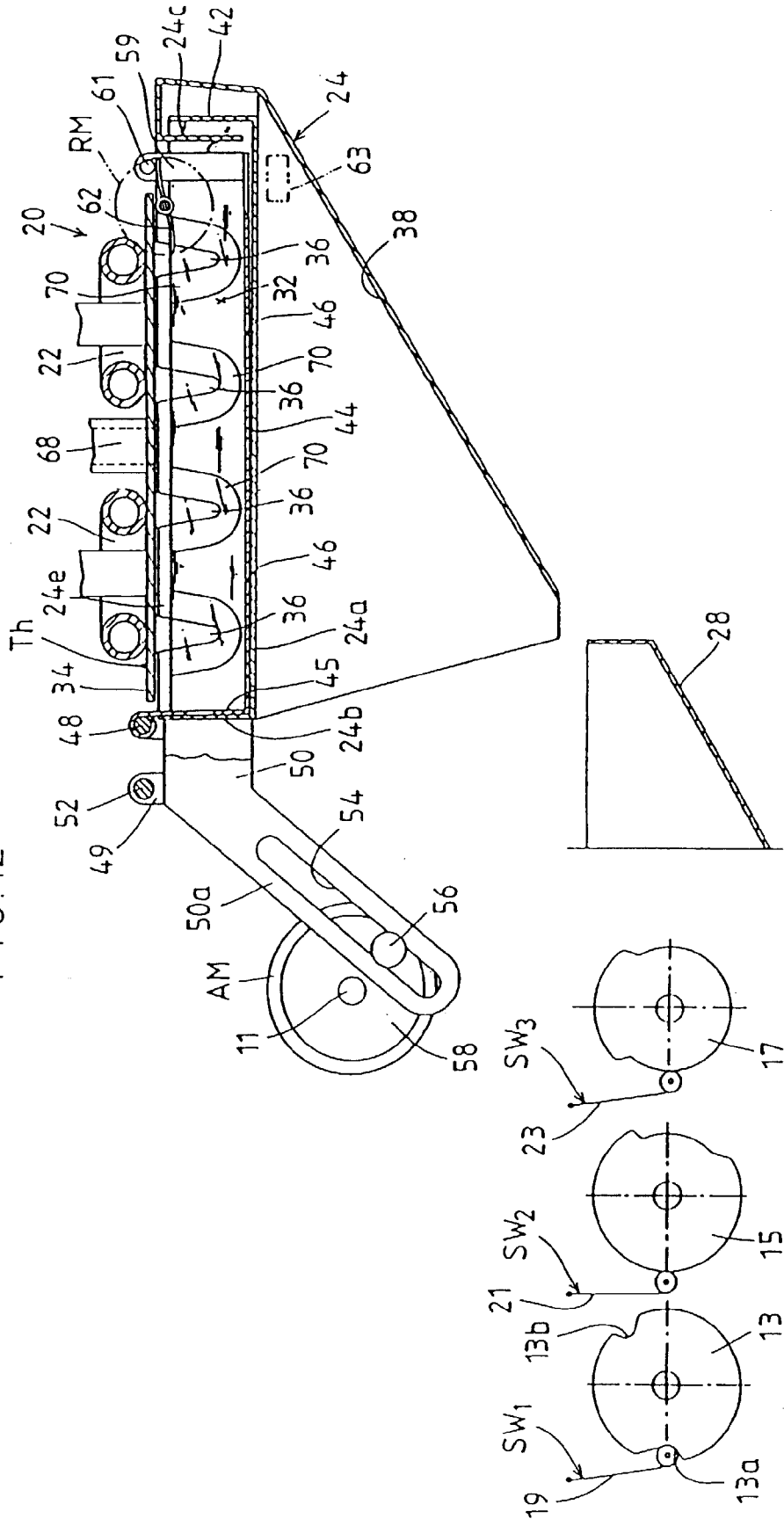

FIG. 13

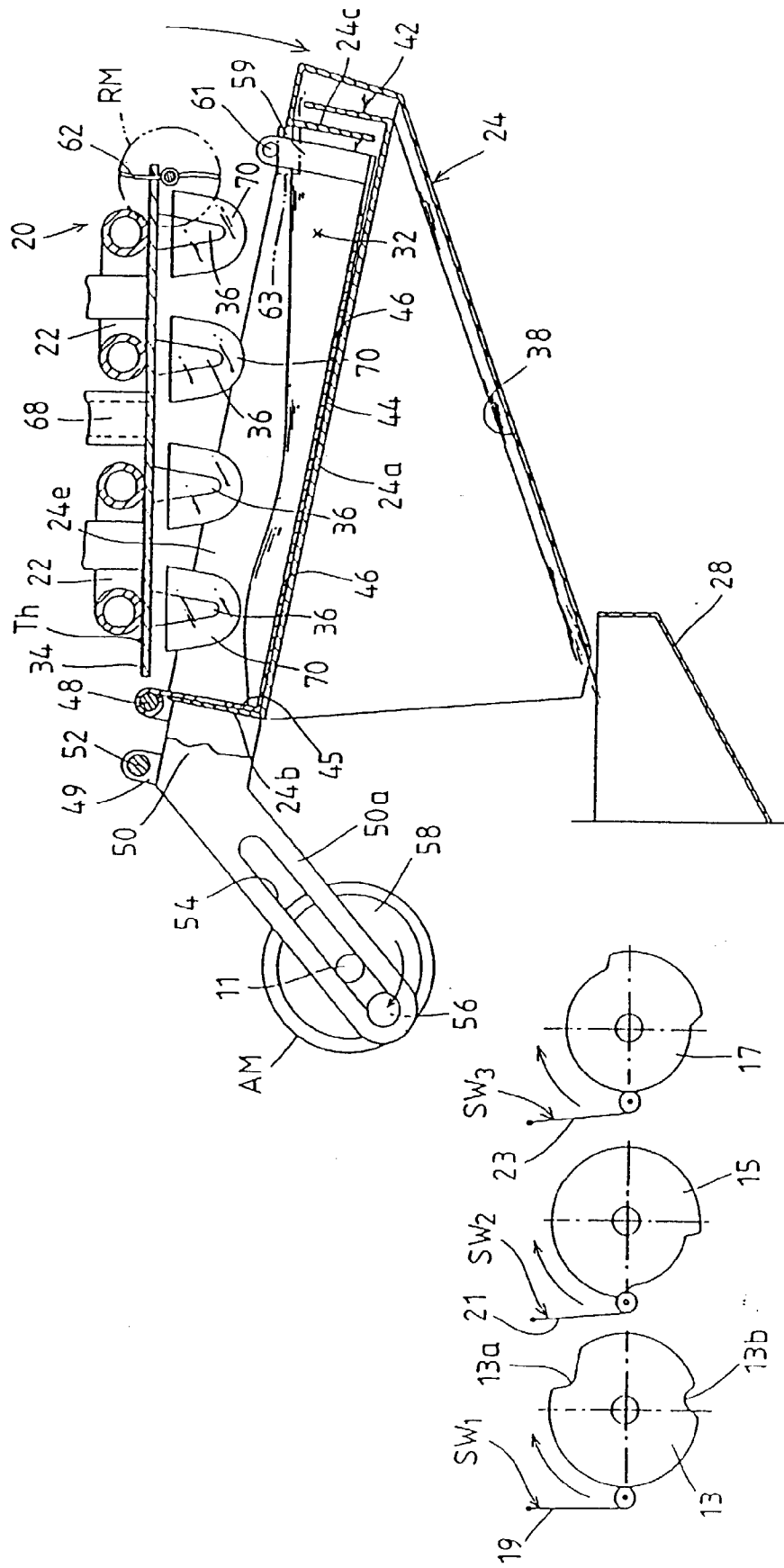



FIG.15

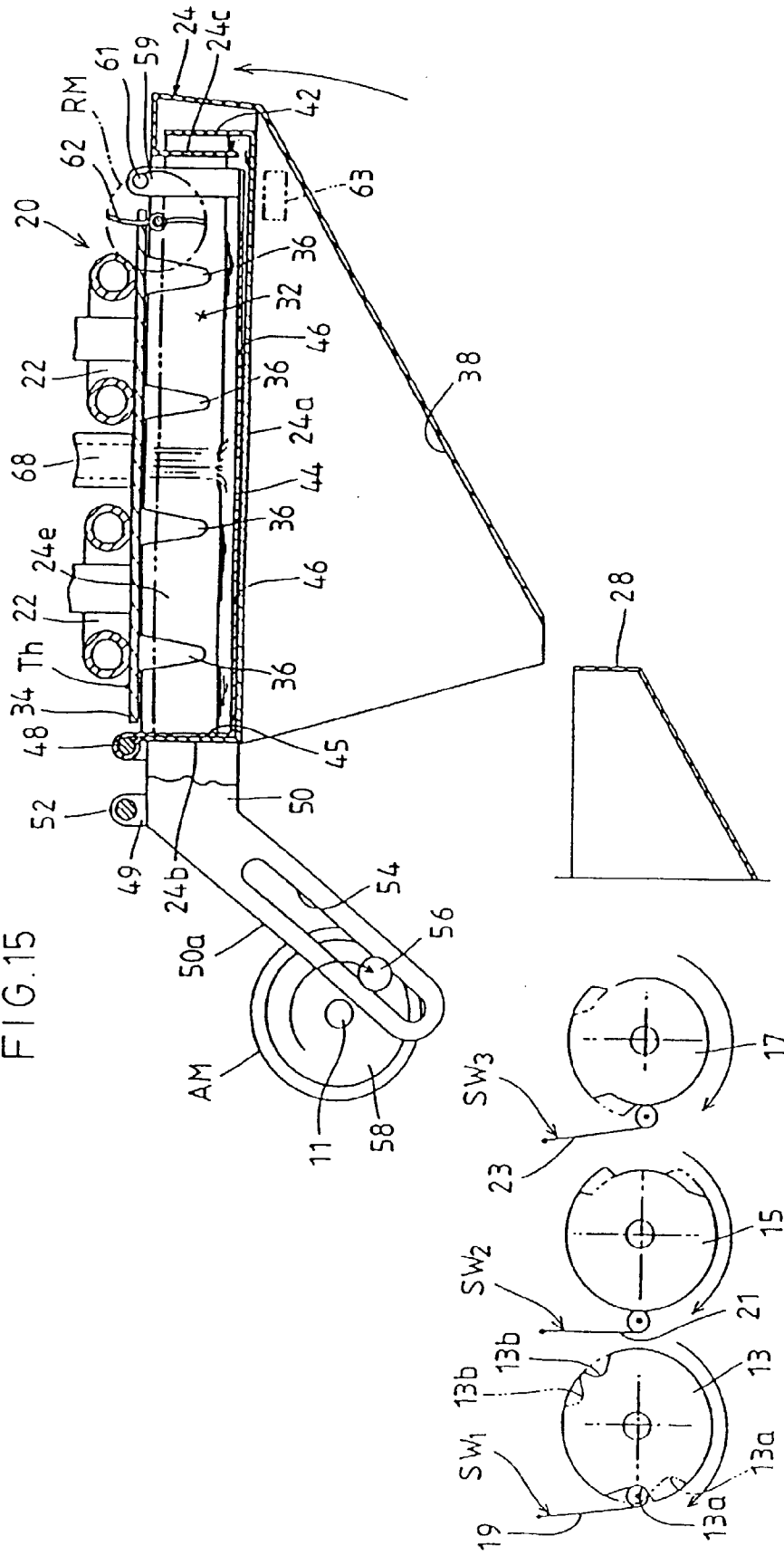



FIG.17

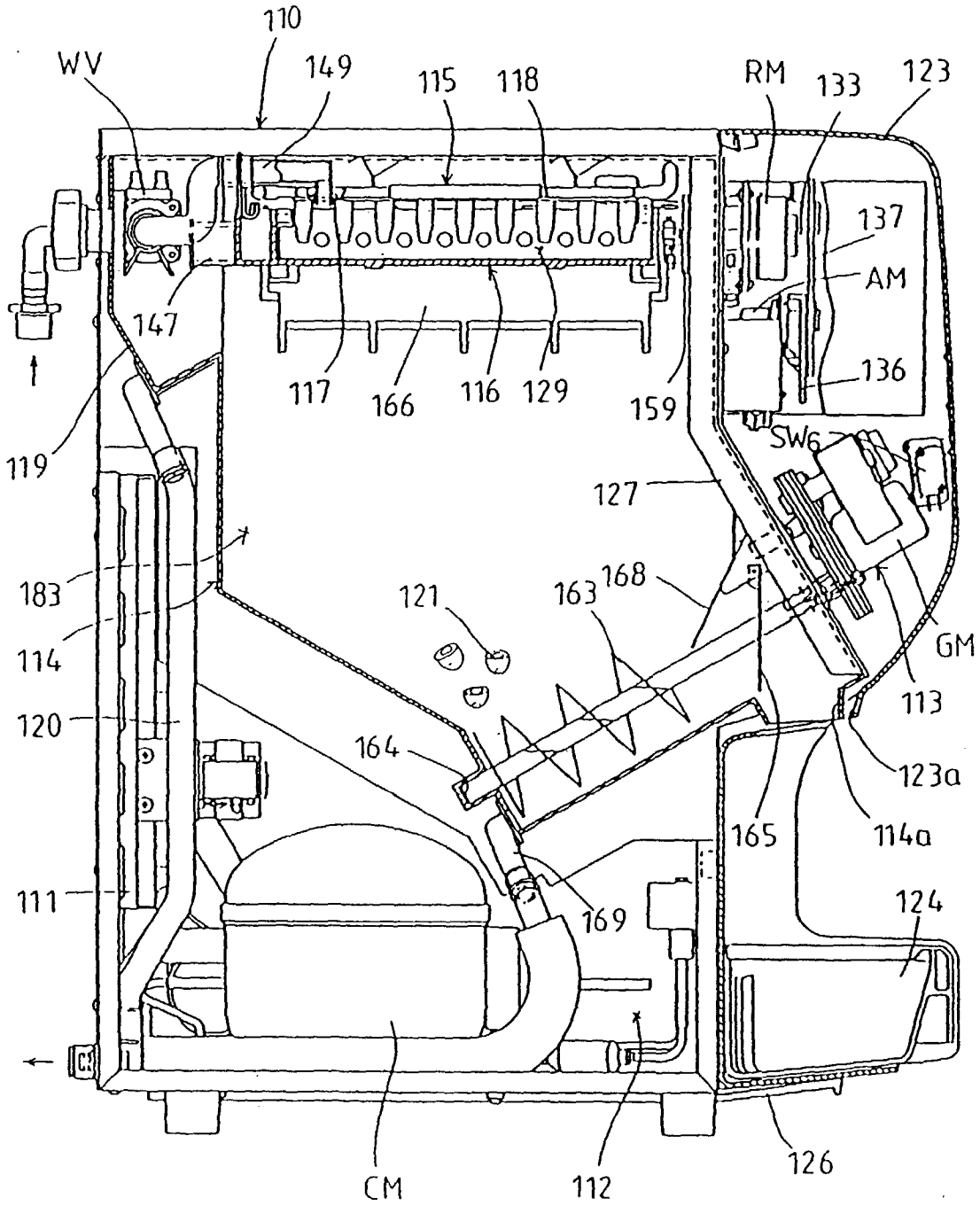

FIG.18

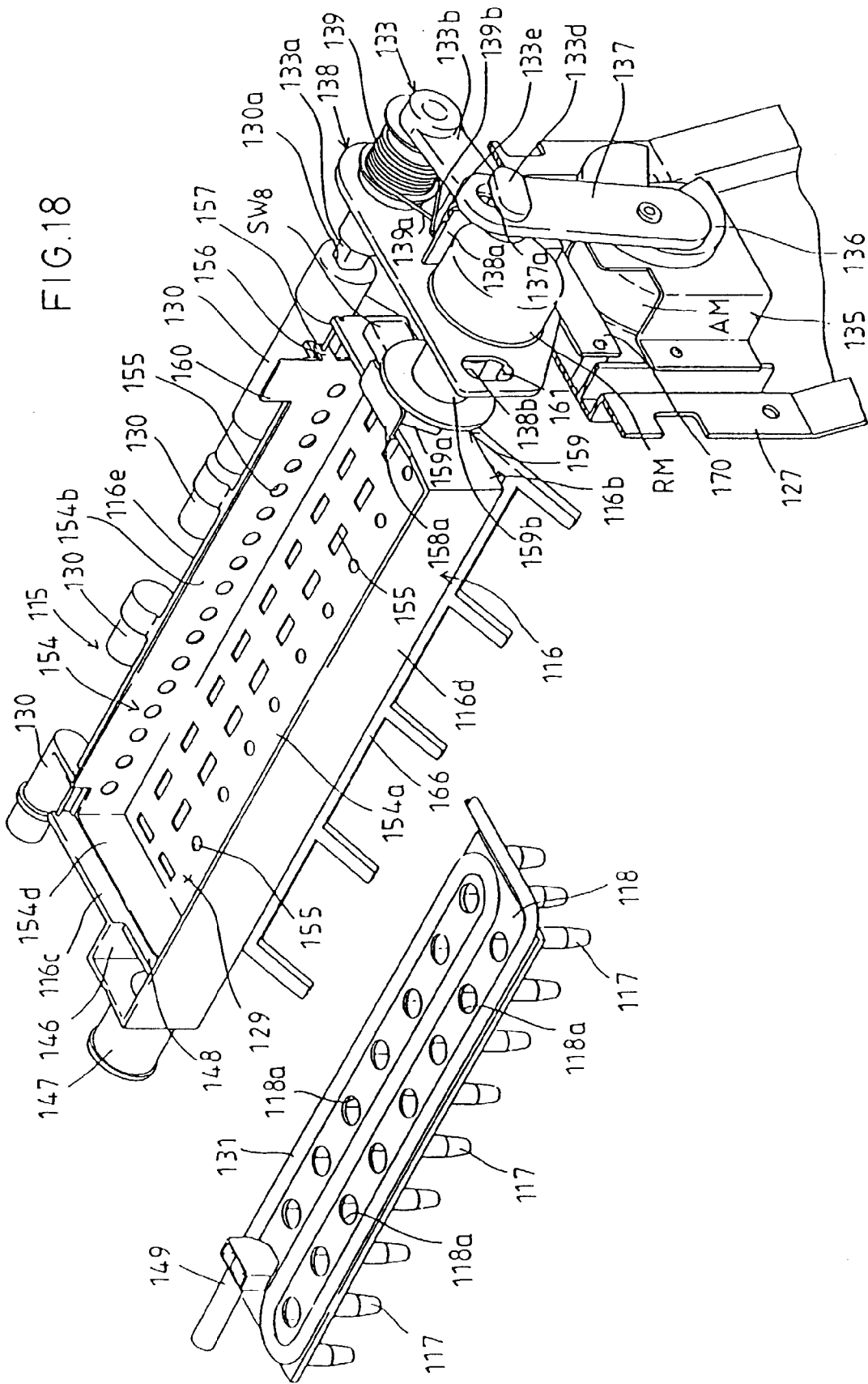

FIG. 19

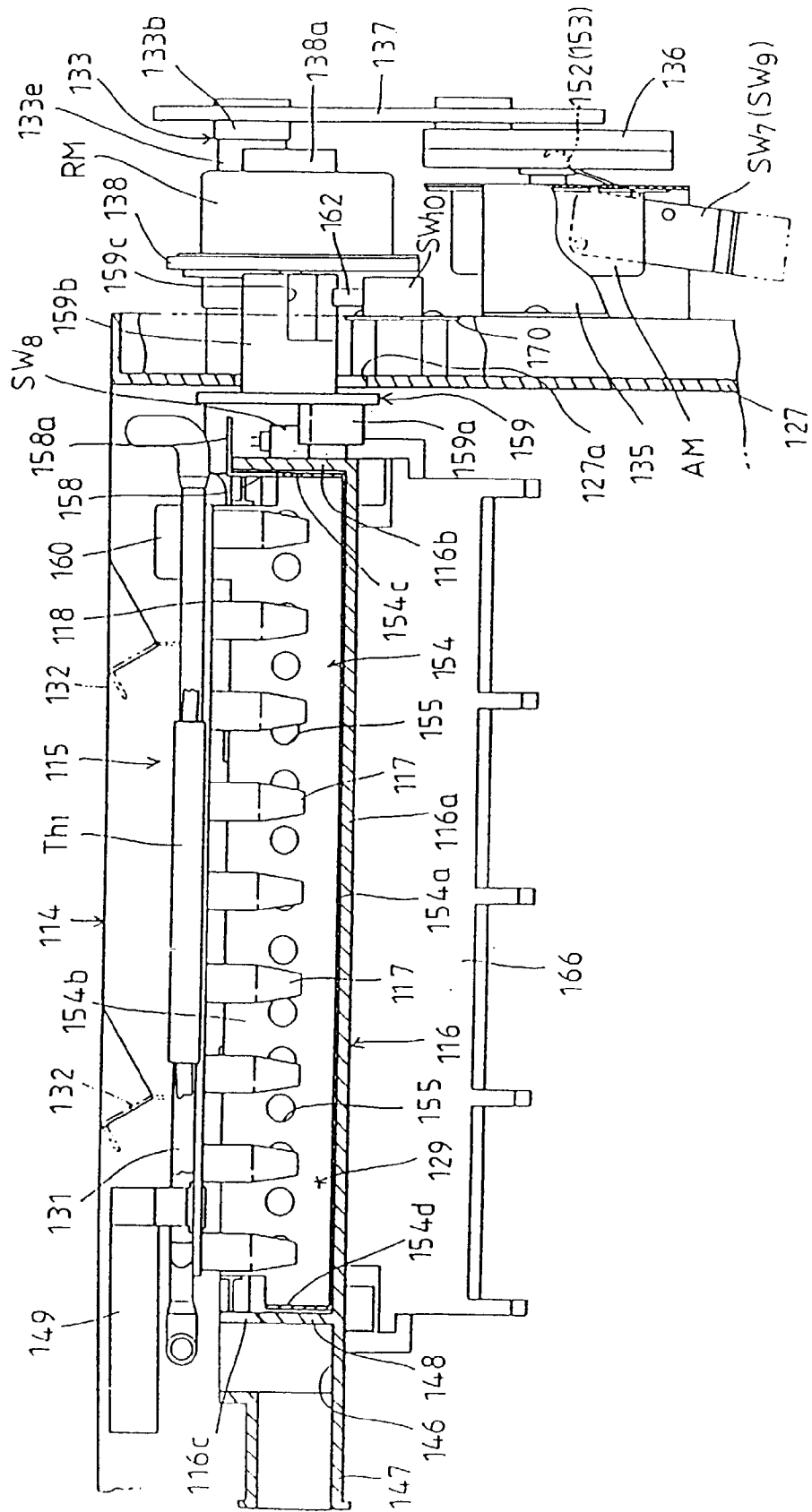
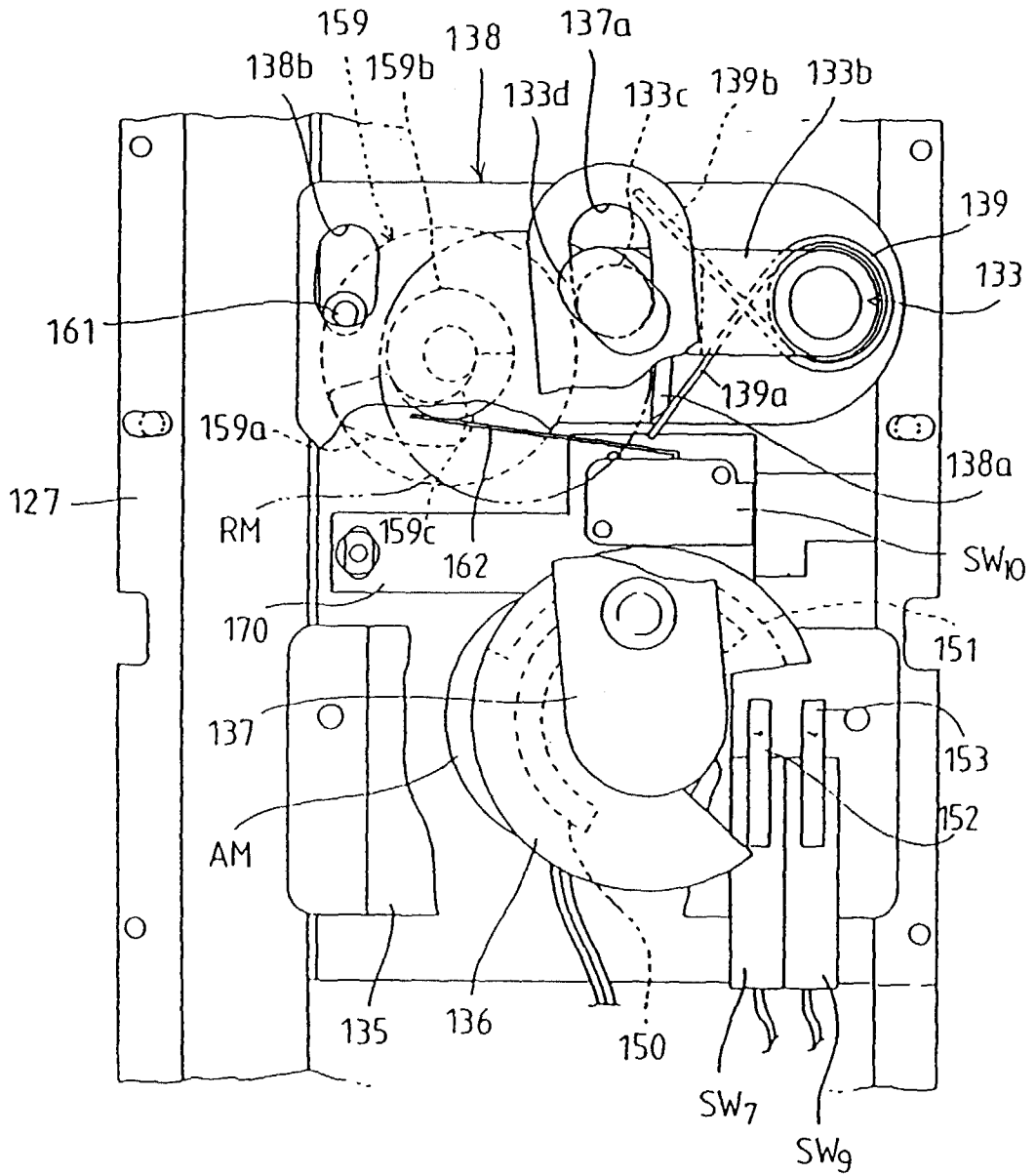

FIG. 20



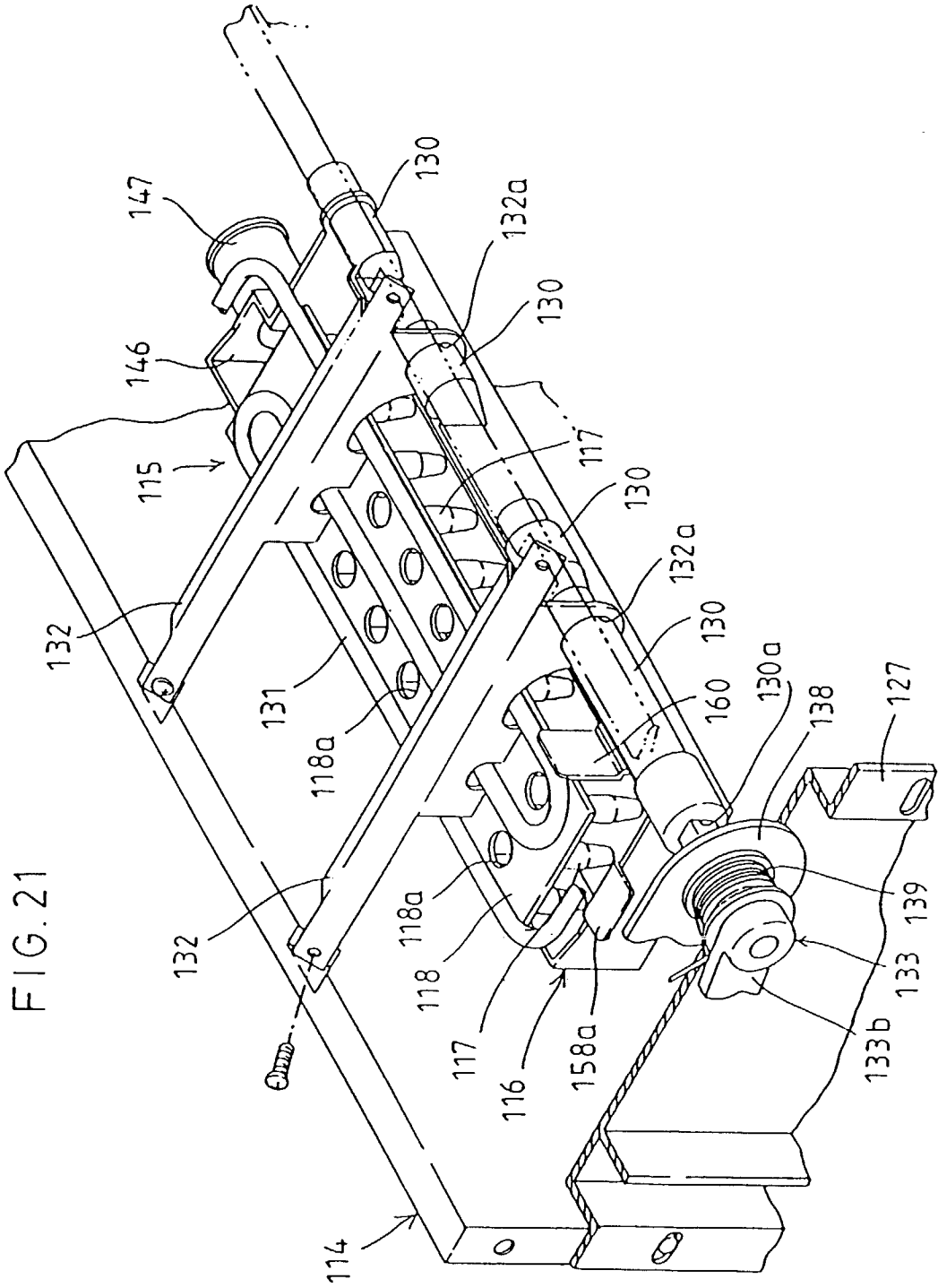

FIG. 22

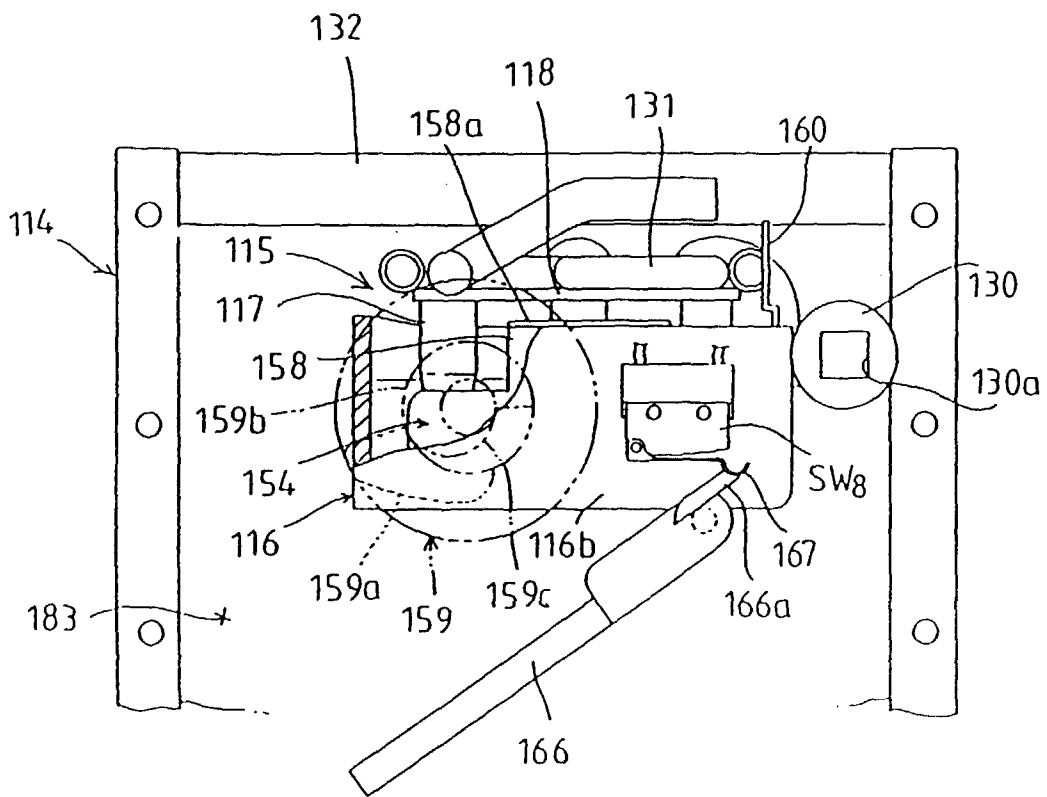

FIG. 23

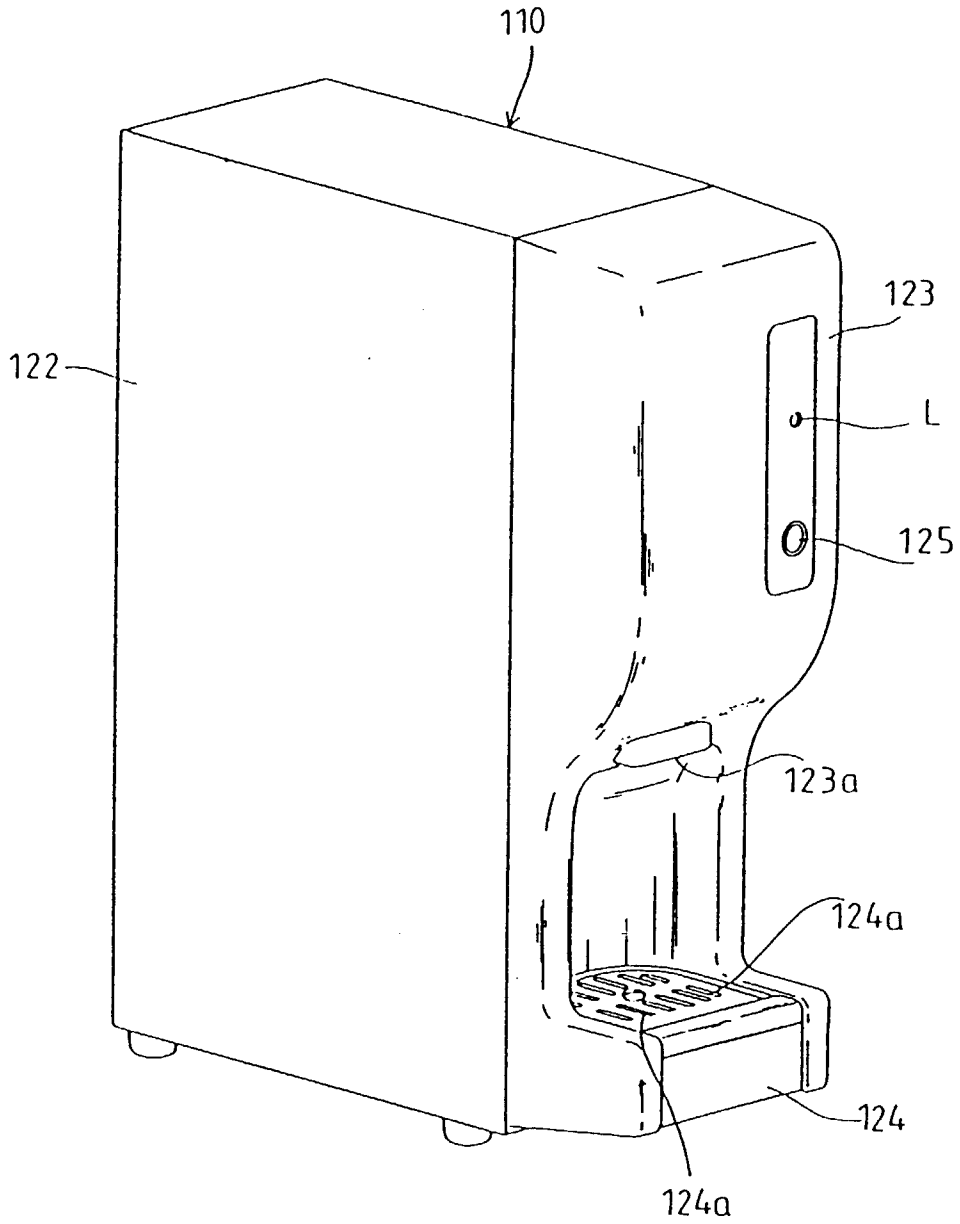

FIG. 24

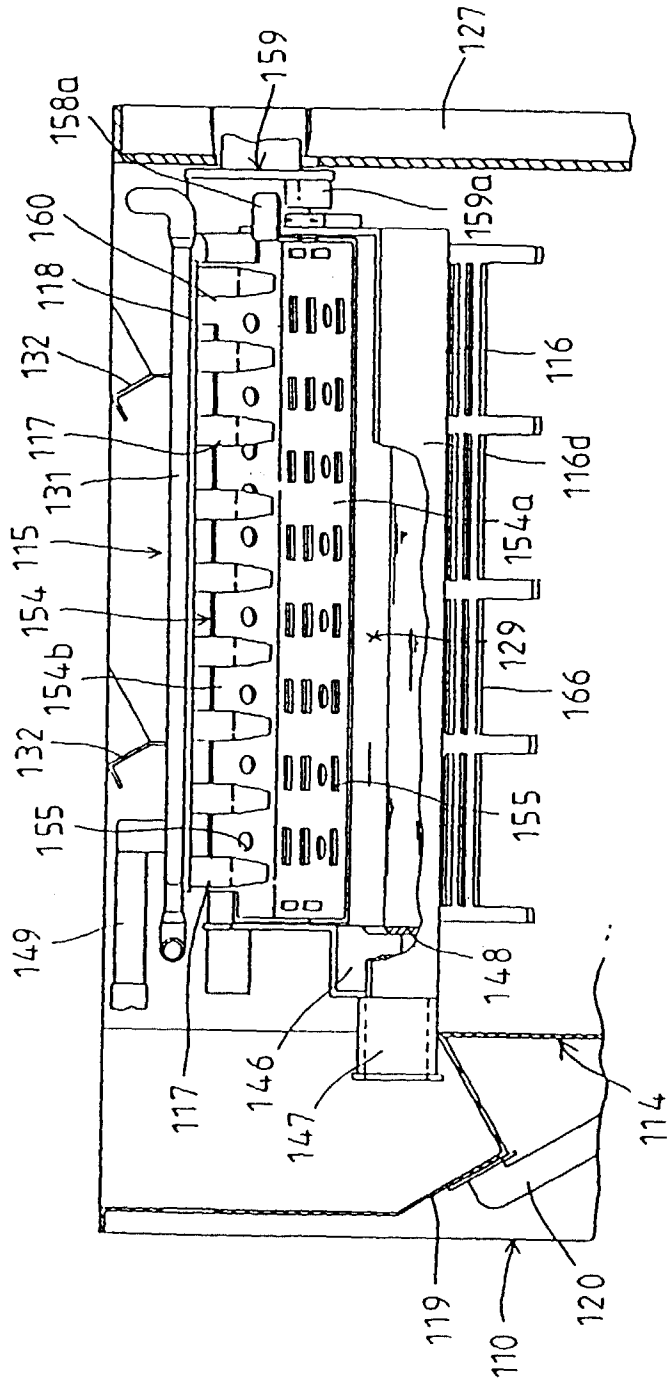



FIG. 26

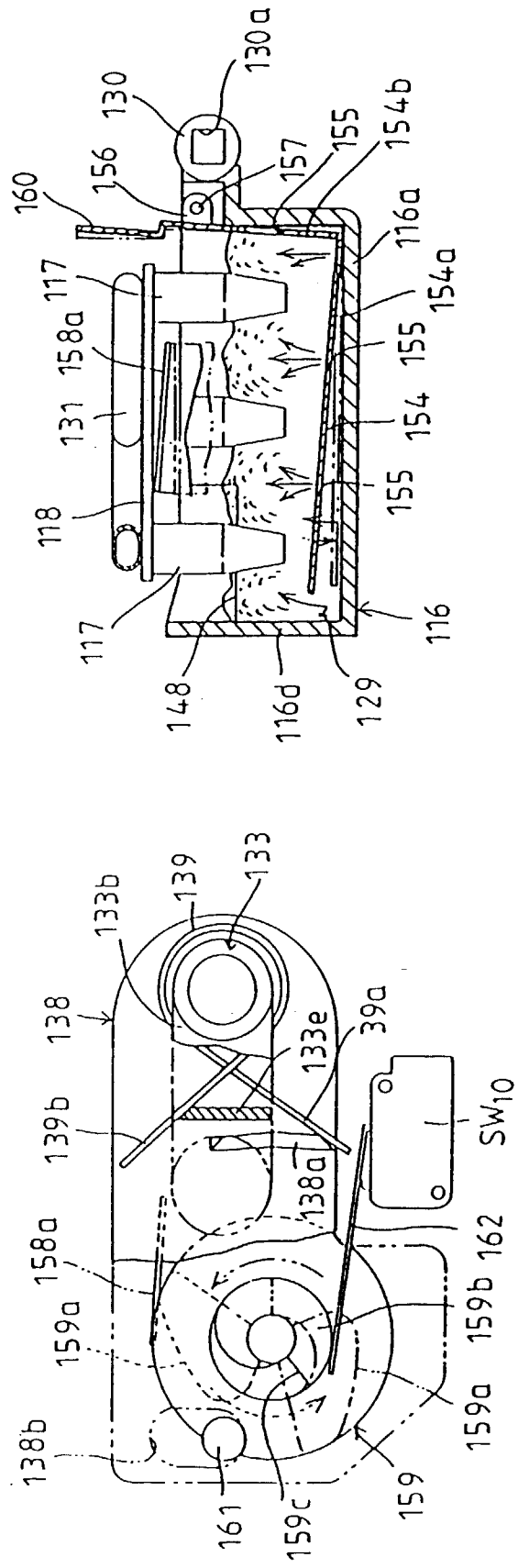

FIG. 27

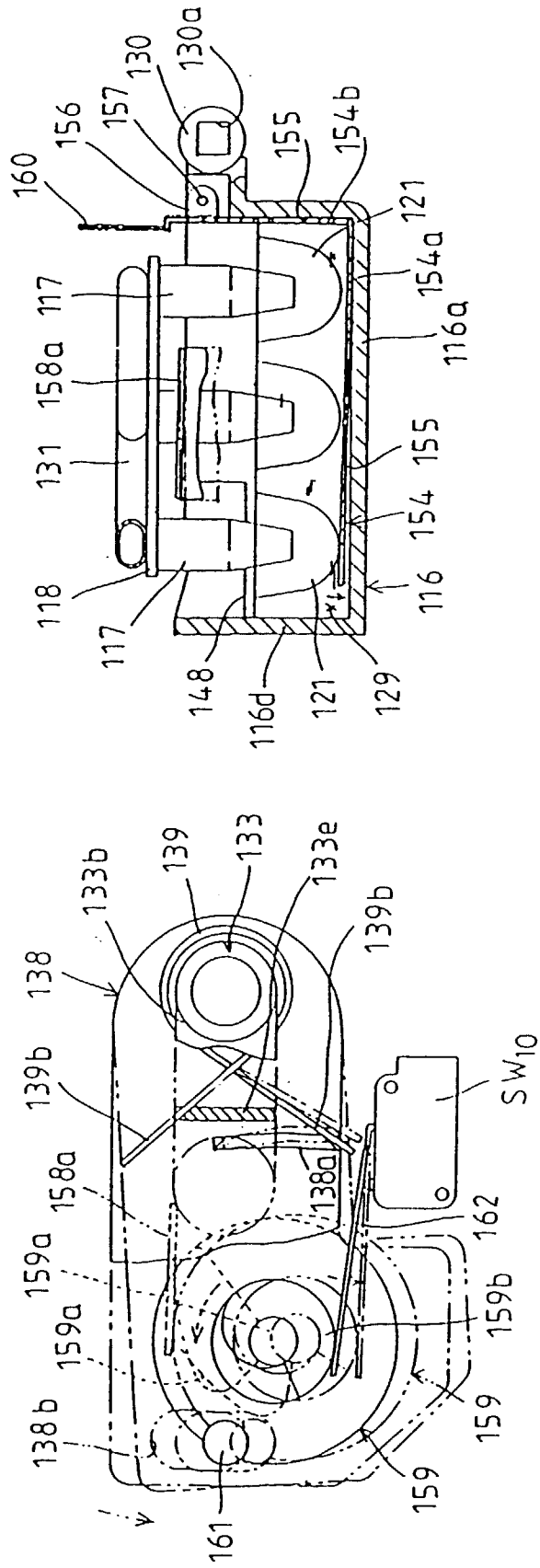



FIG. 29

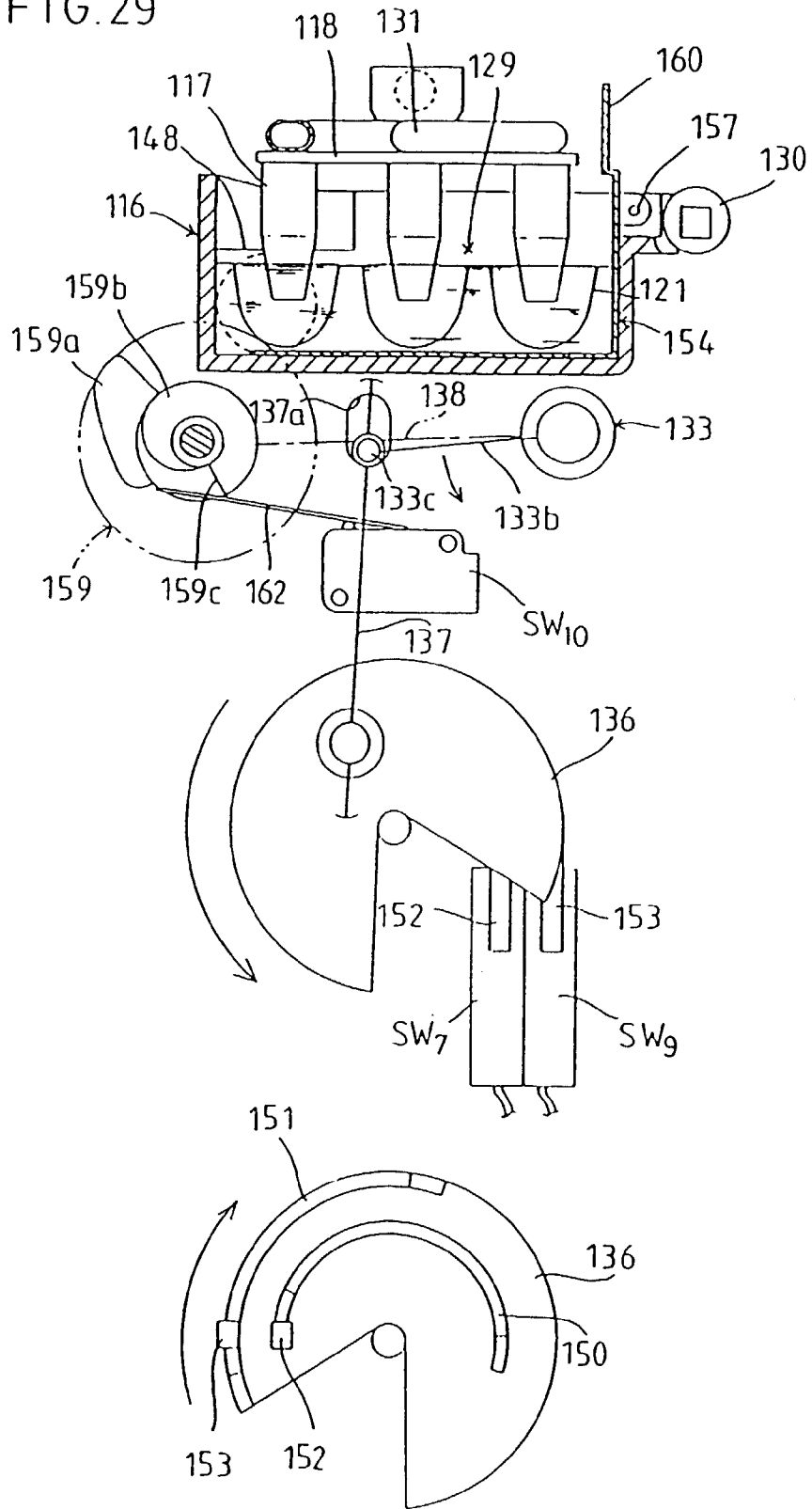

FIG. 30

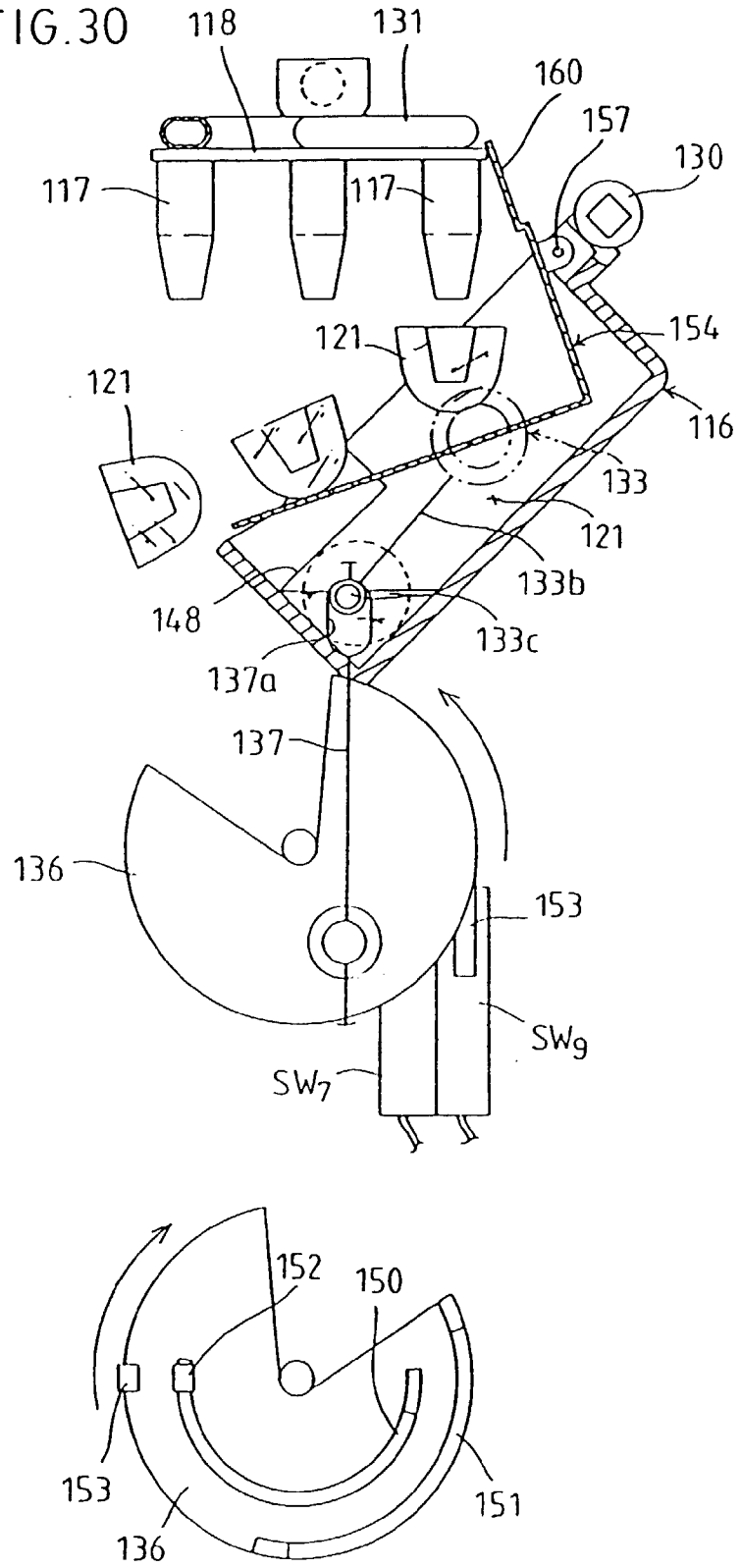

FIG.31

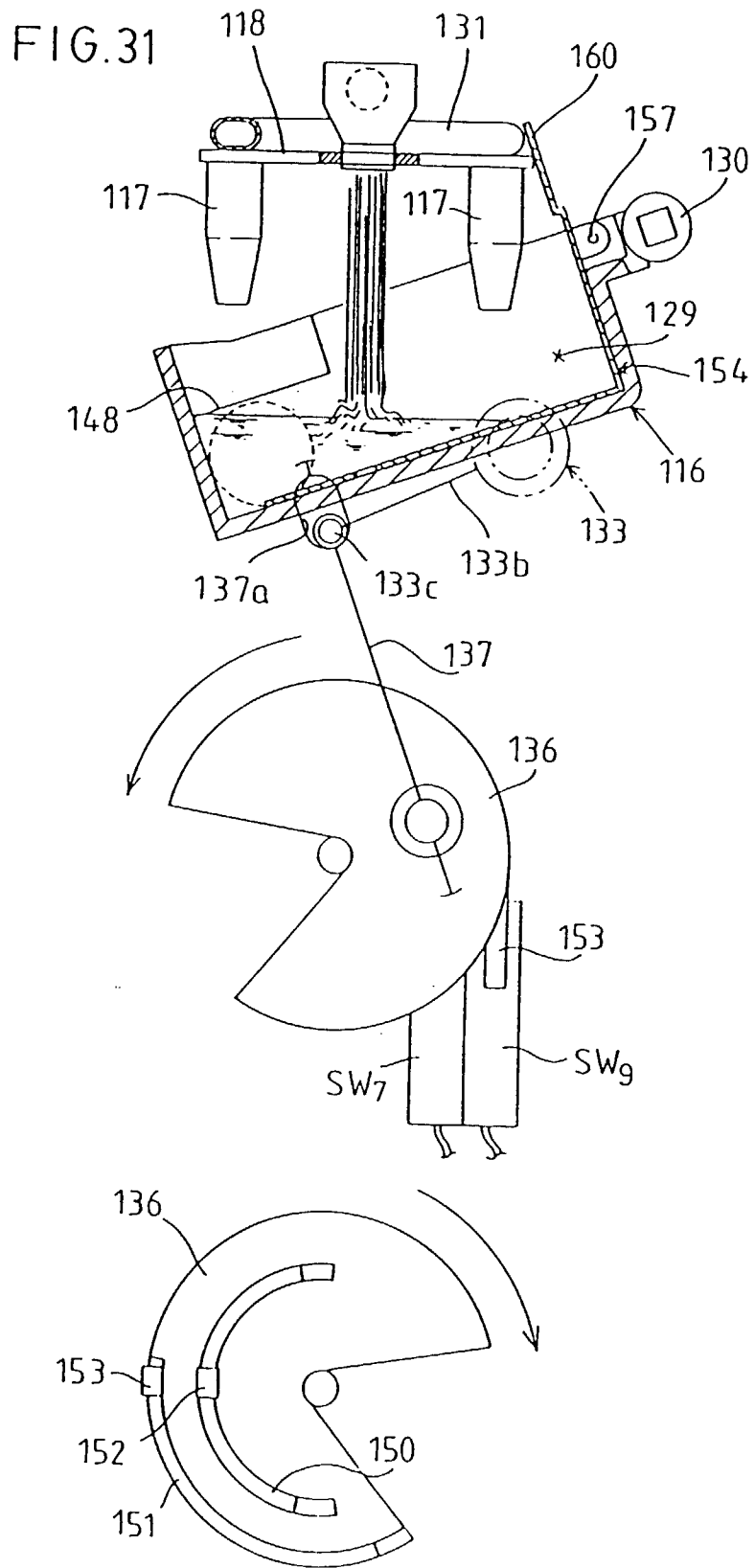
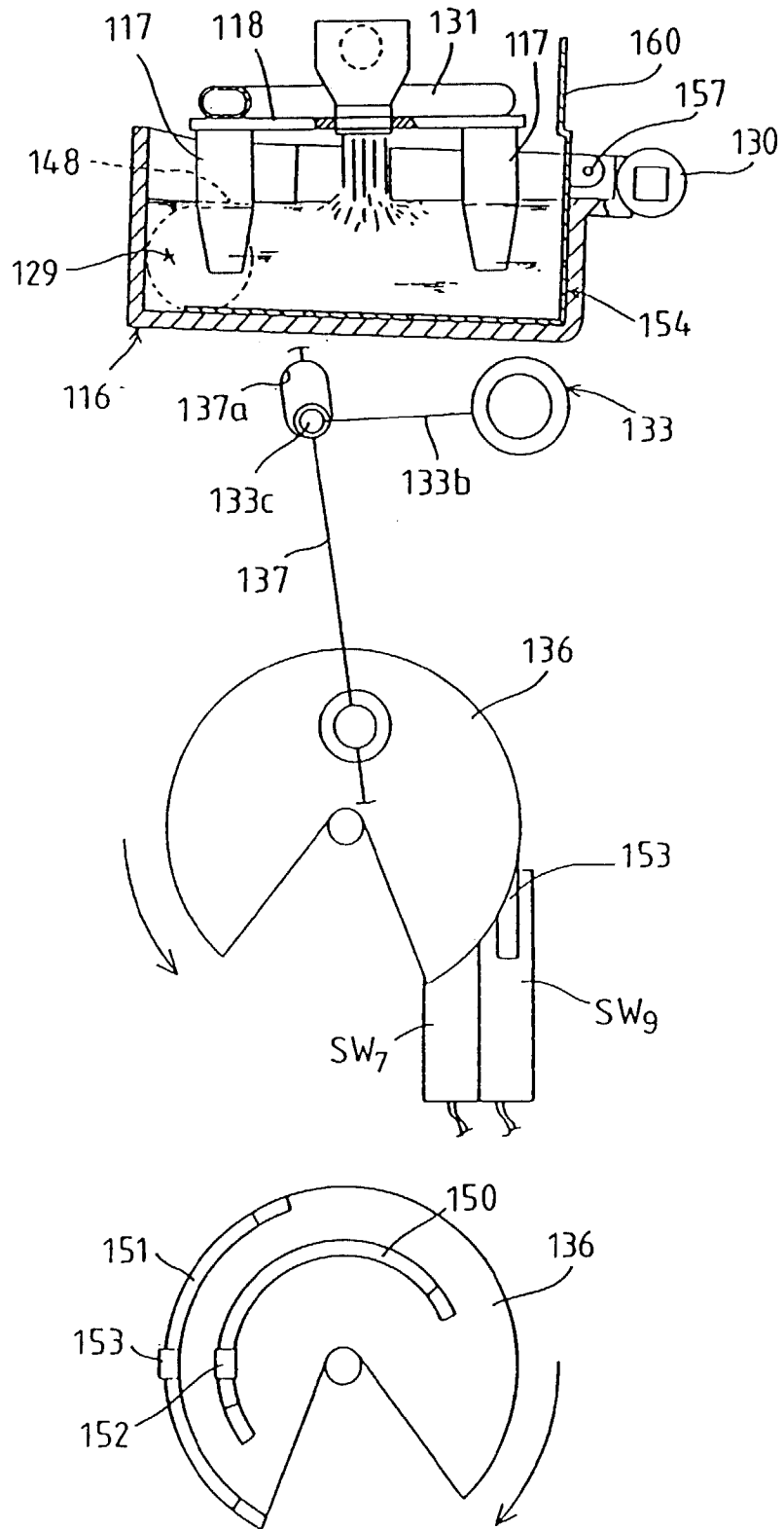

FIG. 32



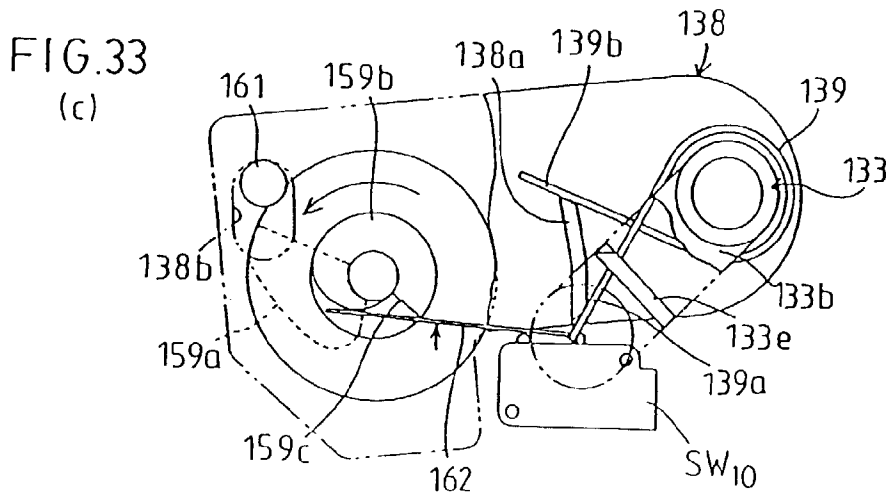
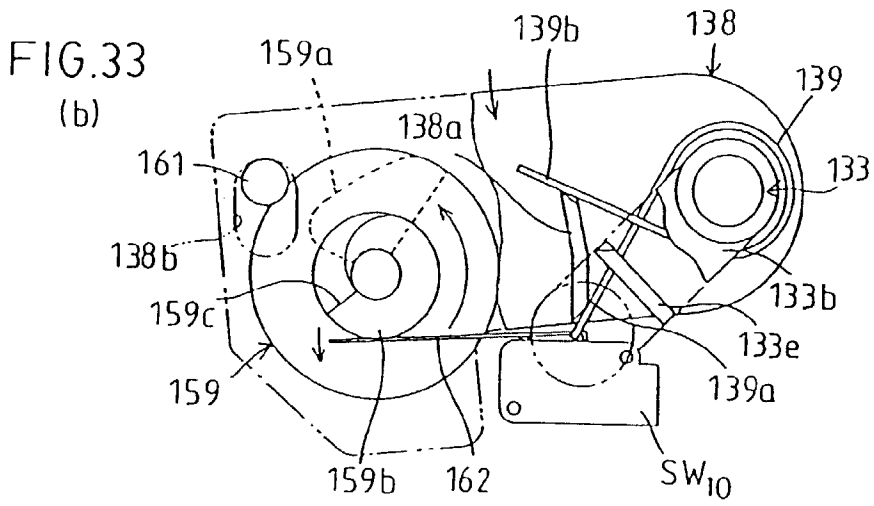
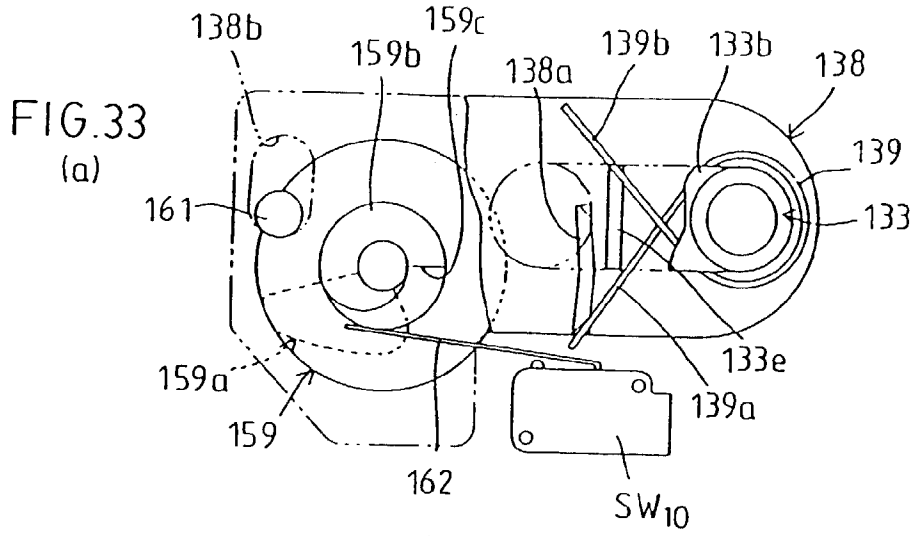

FIG. 34

