



(12) EUROPEAN PATENT APPLICATION

(43) Date of publication:
13.11.1996 Bulletin 1996/46

(51) Int. Cl.⁶: A47L 15/42

(21) Application number: 96107251.9

(22) Date of filing: 08.05.1996

(84) Designated Contracting States:
DE ES FR GB

(72) Inventors:
• Aisa, Valerio
60044 Fabriano (AN) (IT)
• Alluto, Luigi
60044 Fabriano (AN) (IT)
• Olivieri, Gaetano
10024 Moncalieri (TO) (IT)

(30) Priority: 09.05.1995 IT TO950360

(71) Applicant: Merloni Elettrodomestici S.p.A.
I-60044 Fabriano (AN) (IT)

(54) Arrangement for regeneration of the water softening resins in a washing machine

(57) An arrangement for the regeneration of the water softening resins in a washing machine is described, said arrangement comprising:

- a container (R) for the resins used to reduce the degree of water hardness,
- a container (S) for the salt required for the resins regeneration,
- metering means (E.V.) for the water to be delivered to the salt container (S) required for regeneration purposes,

where the resins regeneration processes are carried out periodically in time, in particular at each wash cycle executed by the machine.

The arrangement according to the present invention further provides sensor means (A,B,C,Q,MP) of the hardness of the water from the mains and an electronic control unit (MP) fit to evaluate the optimal water volume for the regeneration steps in function of the degree of water hardness detected by said sensor means (A,B,C,Q,MP) and consequently control said metering means (E.V.).

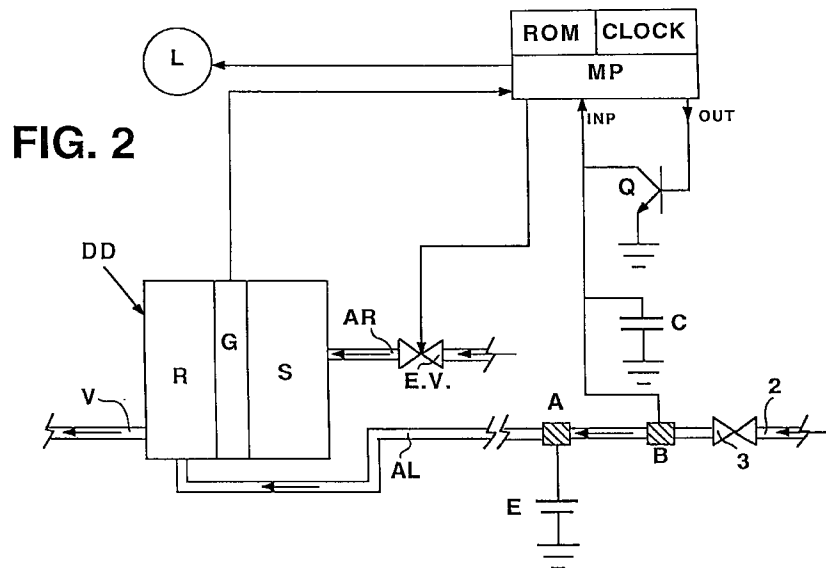

Description

The present invention relates to an arrangement for the regeneration of the water softening resins in a washing machine, as per the preamble of Claim 1, and to a regeneration control method of the resins in a water softening system, as per the preamble of Claim 9.

It is known for washing machines, specifically household dishwashers, to incorporate a softening system, i.e. to dampen the degree of water hardness.

In such systems the washing water from the mains is flown through a resin compartment to reduce its calcium contents that would inhibit the action of the washing agents and cause calcareous deposits.

Decalcifier systems of the above type are already known and in fact they are practically incorporated in all household dishwashers.

Since after a certain volume of softened water said resins become exhausted, they have to be regenerated by letting a solution of water and sodium chloride called brine flow through them. The calcium ions deposited on the resins are then replaced by the brine sodium ions and the resins will be ready again at each washing for a new softening step. To this purpose a regeneration process normally takes place during each wash cycle.

Therefore, the softening systems provide a tank connected with the resin compartment containing the brine obtained with a solution of water and kitchen salt.

This tank must be filled at regular intervals, due to the consumption during the resin regenerating processes. Decalcifier devices of the above type and their regenerating method are already known as such, so their detailed description is not required in this context. On principle, it will be enough to mention here that the higher the water hardness the faster the resins become exhausted. As a result, the quantity of salt consumed to regenerate the resins will also be higher.

In the softening systems presently used, resins regeneration is done starting from a fixed volume of water introduced in the salt compartment for each wash cycle, so that a corresponding volume of brine may strike the resins.

In such systems it is possible, within given limits, to change the regeneration process as a function of the water hardness from the mains. This is done by a manual adjustment, that causes the water flow to change in the salt compartment (such as EP-A-0433676). Thus, by changing the water flow, the brine pushed in the resin compartment may have a higher or lower salt contents.

Such an adjustment is usually made when installing the washing machine and requires to know the degree of water hardness from the mains.

However, such a system is extremely rigid and difficult to use by the user. The adjustment mentioned above may not be performing as the system cannot adapt itself to likely changes to water hardness the user may not notice (as it may occur for instance at season change). Therefore, a wrong use of the resins and a

wrong salt consumption to a certain extent with likely excessive water consumption will ensue.

It is the object of this invention to solve the above problems and specifically provide a washing machine with a softening system for fully automatic optimization in time of the resins regenerating processes in function of the actual degree of water hardness to be softened, for a better use of the resins and salt as well as a globally more efficient use of the softening system.

Said object is obtained according to the present invention through the arrangement of resins regeneration according to Claim 1 and control method of Claim 9, as well as through the learnings described in the annexed Claims forming integral part of this invention.

The characteristics and the advantages of the present invention will be apparent from the following detailed description and annexed drawings, which are supplied only by way of an explanatory and not limiting example, where:

- Fig. 1 shows schematically the hydraulic circuit of a dishwasher machine according to the present invention.
- Fig. 2 shows a simplified block diagram of the control system for the dishwasher machine according to fig. 1 and of the softening arrangement for the water.
- Fig. 3 shows as a schematic diagram the relationship between the degree of water hardness (French degrees), the volume of water used for resin regeneration (centiliters) and the volume of softened water (liters).

Referring to Fig. 1, showing schematically the hydraulic circuit of a dishwasher embodiment according to the object of this invention, reference number 1 indicates a complex device for a number of functions.

Such a device is fed with water through a pipe 2 (connected with the mains line), a solenoid valve 3 and an inlet pipe fitting 4. Water enters device 1 and flows through it in a first pipe up to its top where - in the area indicated by 5 - there is a so-called "air breaker", i.e. a *cutoff* that water overcomes thanks to its acquired *kinetic* energy; said *cutoff* is provided to avoid possible dirty water backflow to the mains.

After overcoming the air breaker, water flows through a second pipe to an outlet connector 6. However, said second pipe has a calibrated hole (not shown) through which a small volume of water flows into a volumetric cavity 7 where it collects.

When the cavity 7 is full, water flows out of it and falls down to the bottom of the device 1 where there is a hole 8 through which the overflow water can directly flow into the washing tub of the machine. The water collected in the volumetric cavity 7 is periodically picked up by a pipe fitting 9 and an intercepting device E.V., such as a solenoid valve, as it will be further described. Leakage water unable to overcome the air breaker will also collect on the bottom of the device 1 and flow directly to

the tub through the hole 8. The hole 8 is also used as a vent for the washing damp condensing in the device 1 and falling down onto its bottom.

Thus the device 1 can execute a plurality of functions, which are all known and do not need any further detailed description (see for instance patent IT-B-1.238.419).

The pipe fitting 6 is used to flow water through a pipe AL to a resin compartment R, making part of a softening device and indicated as a whole by DD, whereas the pipe fitting 9 is connected with a pipe AR, which is used to feed a certain volume of water collected in the cavity 7 to the compartment S, where the brine for resins regeneration is generated. More precisely, when the machine programmer controls the opening of the solenoid valve E.V. the water collected in the cavity 7 can reach the compartment S and an equivalent brine volume can go over to the resins compartment R.

At any rate, the device DD is of a type and operation known as such, so it will not be necessary to describe it in detail.

The resins compartment R is connected with the washing tub by a pipe V, i.e. through a sump 11 fastened on the tub bottom.

Such a sump 11 is also connected through three connectors with a lower spraying arm (12), an upper spraying arm (13) and a discharge tube (14).

Figure 2 shows the control system of the dishwashing machine according to figure 1 and the water softening arrangement. In said Fig. 2 the same reference numbers of Fig. 1 are used to indicate the same elements.

A float device is schematically shown by G, whose position changes according to the quantity of salt available in the compartment S. The float device G is of a type known as such, as for instance the type with a Reed contact actuated by a magnet on a suitable float movable inside a chamber associated with the compartment S.

MP indicates an electronic microcontroller as part of the machine control system.

Such a microcontroller MP can be for instance a part of an electronic or hybrid timer of the machine, i.e. the device supervising the execution of the wash cycles the machine can carry out upon user's control.

The microcontroller MP has a suitable internal clock, named CLOCK, permanent memory means named ROM and nonvolatile read/write memory means, which are not shown.

L is a warning device signaling that salt is lacking inside the compartment S.

According to a different embodiment of this invention described later, illumination of L is not controlled by the float device G, as usually done according to the known state of the art, but through the microcontroller MP.

According to this invention, the volume of water to be introduced in the compartment S for resins regeneration processes is not a fixed and constant one, but is

automatically changed as a function of the degree of water hardness from the mains.

As said, the washing machine according to this invention has a control unit with a microprocessor, which is advantageously programmed according to the fuzzy logic rules. The permanent memory ROM associated with said microprocessor contains an adequate codified knowledge base resulting from the experience of technical people and experimental investigations.

As it will be clarified, the microprocessor MP is fit to decide thanks to this knowledge base the optimal volume of water to be used for the resins regeneration process in function of the hardness degree of the water detected at each wash cycle.

To this purpose, suitable measurement means provide the control unit with information related to the physical characteristics of the water to be used for washing.

Specifically, the machine according to this invention is provided with a device to measure the resistivity of the water from the mains, which is used according to the invention to measure the degree of water hardness.

Such a device comprises two electrodes shown in Fig. 1 with the letters A and B, consisting of electrically conductive elements inserted on the water inlet pipe 2 from the water mains. Said two electrodes A and B are obviously electrically insulated from each other.

Connecting the electrode A to the positive pole of a direct voltage generator E (eg. E=5V) and earthing the electrode B (negative pole of the same voltage generator E) through a capacitor C of adequate capacity, and since water in 2 is surely conductive, there will be a current flow from A to B proportional to the resistivity of washing water inlet from the water mains.

Such a current flow feeds a charge transient of capacitor C and stops upon conclusion of such a transient, i.e. when a voltage equal to the value of E is available at the terminals of capacitor C. The duration of the transient generated by the microcontroller MP depends on the capacity of the capacitor C and on the resistivity value of the medium through which the charge current is flowing, i.e. water from the mains. Once a proper value of capacitor C (eg. C=1 microfarad) has been established, it is possible to obtain information about the resistivity of the washing water by measuring the charge time of said capacitor C. Such a measurement of the charge time is executed by the microcontroller MP, whose internal clock (CLOCK) is able to measure the time with a good resolution (eg. with 1 microsec resolution).

A digital input of microcontroller MP, indicated by INP in Fig. 1, is connected with the terminals of capacitor C, whereas one digital output, indicated by OUT, is used to pilot a transistor Q used as a switch to control the transient and whose manifold is connected with the terminals of capacitor C.

The charge time of capacitor C is measured by the following steps of microcontroller MP:

- fast discharge of capacitor C, obtained by applying a short pulse (eg. 1 millisecc duration) to the base of the transistor Q through the output OUT, so it will saturate and shortcircuit capacitor C to earth;
- start time count right when the transistor Q - having terminated the discharge pulse of the capacitor C - goes back to its lock state, so allowing for the capacitor to start its charge;
- time count stop right when voltage at the capacitor terminals reaches the tripping threshold of digital input INP, whose value is typically equal to half the feed voltage of the microcontroller MP (i.e. $E/2=2.5V$);
- the value reached by the time counter available inside MP at count stop is directly related to the intrinsic resistivity characteristics of the washing fluid.

As it can be understood, the microcontroller MP duly programmed according to the fuzzy logics techniques and with an adequate knowledge base, is capable of calculating water resistivity following a measurement of the charge time of said capacitor.

Similarly, the microcontroller is capable of calculating the degree of the water hardness from the mains, which is easily obtained from the water resistivity value through the above knowledge base in fuzzy logic.

Therefore, as it can be desumed, the electronic control system of the machine according to this invention is suitable to know the degree of the water hardness through the sensors A and B. Moreover, it also appears easy to insert in the ROM memory of the microcontroller MP any information derived from experience, related to the optimal water volume to be used for regeneration as a function of the degree of water hardness and, wherever desired, of the number of wash cycles executed and of the total volume of softened water within a certain period of time.

To such a purpose, the nonvolatile ROM storage contains proper tables or algorithms, indicating for instance, for each degree of hardness detected, comprised in a preset range of values, the optimal volume of water to be used for each resins regeneration (i.e. in the specific instance, the opening time of electrovalve E.V.).

Operation of the washing machine according to the present invention is as follows.

The user starts the machine and the solenoid valve 3 opens, so as water coming, through 2 from the water mains, as described above, can flow through the device 1 and reach the washing tub through pipe V. Upon reaching a determined water level inside the tub (detected by a special sensor, such as a pressure switch or a turbine measuring device), the control system causes the solenoid valve 3 to close.

During such a water supply, as mentioned above, the volumetric cavity 7 of the device 1 fills in, as during this stage the solenoid valve E.V. remains closed. Always during this supply step the microcontroller MP

calculates through the means A, B, C, Q the degree of the water hardness taken in, as described above.

The water supplied in from the mains reaches the tub softened, by its flowing through the resins compartment. The wash cycle is then performed in a usual known manner.

At a given step of the wash cycle the control system of the machine will control the execution of the resins regeneration.

Such a step is performed by the microcontroller MP by controlling the opening of the solenoid valve E.V. for a given period of time, calculated by the internal clock CLOCK. Such a determined opening time of the solenoid valve will obviously correspond to a well determined volume of water flowing from the cavity 7 to the salt compartment S. Thus, an equivalent volume of brine will flow from the compartment S to the resin compartment R (of course such a determined volume of water will be lower or at the maximum equal to the capacity of the cavity 7, which in this specific example is 190 cc).

As mentioned, the opening time of the solenoid valve E.V. is selected by the microcontroller MP as a function of the degree of the water hardness previously taken in and flown through the resins.

In other words, according to the present invention, the knowledge base codified in the ROM memory contains the information to let the microcontroller decide the optimal volume of water or brine to be used for the resins regeneration in function of their reduced softening performance. Since such a performance decreases proportionally to the degree of water hardness, said knowledge base will include experimental data based on experience, which indicate the optimal water volume to be delivered to the salt compartment to obtain a correct volume of brine as required for regeneration.

Thus, the nonvolatile ROM storage contains proper tables or algorithms pointing out to the microcontroller MP the opening time of the solenoid valve E.V. for each value given by the hardness sensor included in a preset range of values.

An example of the above knowledge base is reproduced as a diagram in Fig. 3, showing on the abscissa axis the sum of the volumes (liters) of the softened water in a sequence of several wash cycles, on the ordinate axis the possible values of water hardness (French degrees or dHF) and on the horizontal arrows the volumes of water (centiliters) used for the resin regeneration and the relevant activation times of the solenoid valve E.V. for the control of the regeneration water.

As it can be noticed, in the instance of the water from the mains having a hardness of 60 dHF, which is a very high hardness value, each regeneration step will be performed with 190 cc of water, i.e. using all the water contained in the cavity 7 (in such a case the solenoid valve E.V. will be energized, i.e. maintained opened, for 40 secs).

If the water from the mains has a hardness of 30 dHF, which is a medium hardness value, each regener-

ation step will be performed with 80 cc of water, corresponding to 8 secs of energization of the solenoid valve E.V.

If the water from the mains has a hardness of 10 dHF, which is a relatively low hardness value, each regeneration step will then be performed with 30 cc of water, corresponding to 3 secs opening of the solenoid valve E.V.

According to the present invention, the microcontroller MP is further programmed to periodically perform a regeneration step using all the water contained in the volumetric cavity 7, i.e. 190 cc of water.

Such a complete regeneration step is activated by the control system with the purpose of avoiding production in time of brine preferential paths inside the compartment R, which could finally damage the resin performance. As an example, if reduced water volumes are extensively used for regeneration, a portion of the resins may not be flown through by the brine due to these paths and become eventually exhausted.

Therefore, according to the invention, such a complete regeneration step is provided at given intervals depending on the degree of water hardness and on the water volume (a complete step is useless if regeneration steps are carried out at a hardness level equal to 60 dHF) globally softened after execution of the last complete regeneration.

As an example, with water hardness up to 24 dHF, the complete regeneration will be performed after the resins have softened 125 liters of water; with hardness ranging from 25 to 34 dHF the complete regeneration will be performed after the resins have softened 100 liters of water; with hardness ranging from 35 to 44 dHF the complete regeneration will be performed after the resins have softened 75 liters of water; with hardness ranging from 45 to 54 dHF the complete regeneration will be performed after the resins have softened 50 liters of water and above 55 dHF regenerations will practically always be complete, i.e. performed with 190 cc of water.

It is evident that the machine control system is perfectly capable of performing such a counting, since the volumes of water taken in by the machine can be easily counted by the microcontroller (eg. as a function of the number or type of wash cycles carried out or through the countings performed with the aid of the machine pressure switch).

As described above, it will be apparent that in the machine according to this invention the regeneration processes are performed as a function of the real needs to restore the resins effectiveness, which is obtained in a fully automatic way at each wash cycle, without any actuation from the user. Thus, the described system also allows a better consumption of both the salt and regeneration water.

The characteristics of the present invention as well as its advantages appear quite obvious from the above description

It is obvious that many changes to the washing machine described by way of example are possible for

the man of the art, and it is also clear that in the practical use of the invention the components described can be replaced with other technically equivalent elements.

A first possible variant embodiment relates to the enabling system of the warning light L, signalling when salt is lacking in the compartment S.

The float signal system typical of the known state of the art appears to be sufficiently reliable only to switch off the warning light L after a salt filling of its tank by the user.

Viceversa, such a float system is often very approximate to indicate the lack of salt.

Therefore, it is the basic object of the proposed variant to use only the reliability of the signal that the salt level has been restored by the user and electronically manage the lighting process of the warning light L, based on the measurements and processes that the microcontroller MP always performs in function of the water hardness and consequently of the resins regeneration cycles executed by the machine.

As said, the electronic control system of the machine according to the present invention is fit to know the degree of water hardness through the sensors A and B.

Moreover, it is very easy to insert in the ROM memory of microcontroller MP also the information derived from the experience, related to the typical salt consumption procedures according to the kind of regenerations performed.

Thus, during each washing, the microcontroller MP can update a proper counter for the regeneration cycles or softened water volumes through its own nonvolatile read/write memory means.

From the above it will already be apparent how according to the invention the total number of cycles to be reached before the signal of salt exhaustion can be automatically selected by the control system, considering the capability of each wash cycle of consuming salt.

In order to adequately develop said counting function, it is necessary for the machine control system to detect when the user restores the salt level in the proper compartment S, so that the microcontroller MP may reset its internal counter for the regeneration cycles (or volumes of softened water) and start a new counting cycle.

To this purpose, i.e. to have a suitable feedback concerning the time of salt level restoring by the user, the signal associated with the reed contact of the float device G can be conveniently used, which is practically reliable only when salt is introduced in the relevant compartment. An important condition to be complied with to this purpose is the fact that the reed position must be such to warrant the closing of the relevant contact also when salt concentration is not very high. This because the reed contact according to this invention simply provides for "resetting" of the signal system and does not inform the user of the need to restore the salt level. This can be obtained eg. by selecting the reed position to cause the contact closure already when only half the

required salt quantity is available or anyway a position such as to warrant the contact closure even in the worst working conditions with lower salt concentrations than the highest one foreseen.

Operation of the washing machine according to the suggested variant is as follows.

The float system G is calibrated to detect the introduction of a determined quantity of salt by the user. Therefore, to cause the warning light L to switch off, if lighted, the user has to introduce in the compartment S a quantity of salt at least enough to also determine the opening of the reed contact and consequently reset the control device of the warning light L. Thus, the opening of the reed contact associated with the float will also inform the microcontroller MP that the user has introduced at least a certain quantity of salt, so the microcontroller will then reset said internal counter.

Then the microcontroller MP starts a new counting of the cycles following introduction of the salt in the compartment S.

As mentioned above, such a counting is executed by detecting the degree of water hardness of each cycle. Thus, the microcontroller MP evaluates according to the codified data in its memory, the capability for each cycle to consume salt during the relevant regeneration process. In a certain sense, the microcontroller operates a "ponderated average" of resin regenerations till a preset limit value based on the experience and codified in the microcontroller memory is reached, at which level no more salt should be available in the compartment S. Thus, in the machine according to the invention the salt lack is not detected in a physical way but deduced by the microcontroller MP according to the data obtained through investigations based on measurements and experience. The microprocessor MP is thus able to calculate a "virtual" salt level inside the relevant compartment S, washing by washing and when such a virtual level goes down to a preset minimum value, it is the microcontroller itself that will switch the warning light L on.

At this point, the user is requested to introduce new salt in the compartment S, causing a new resetting of said microcontroller MP counter, switching-off of the warning light L and starting a new count as described above.

According to the suggested embodiment, the control unit is able to make a relationship between the water hardness values, the volume of regeneration water and the volume of softened water to obtain the signal that salt is lacking.

Going back for instance to Fig. 3, where hardness equals 60 dHF, each regeneration will be executed with 190 cc of water. In this case, as shown on the abscissa axis, illumination of the warning light will be enabled by the microcontroller after having softened about 740 liters of water.

Viceversa, with a hardness equaling 10 dHF, each regeneration will be executed with 30 cc of water: in this case illumination of the warning light will be enabled by

the microcontroller after having softened nearly 3000 liters of water.

From the above description it will be apparent how, through a proper programming the microcontroller MP can evaluate exactly the salt consumption and enable the relevant signal with extreme accuracy.

In the embodiment described by way of example it was already underlined that the float system G practically has the sole function to inform the control logics MP when salt is filled in the tank S. However, it is obvious that such indication can be supplied to the microcontroller MP in a different way, eg. providing a special control element actuated by the user.

Finally, it should be mentioned that the use of a microprocessor aided control system programmed in conformity to the fuzzy logic rules allows the microcontroller MP to execute more sophisticated processes to calculate the water volumes required for regeneration and/or calculation of the quantity of salt consumed.

In this frame, the knowledge base of the microcontroller MP may contain information to calculate the optimal volumes of regeneration water or quantities of salt consumption not only as a function of the water hardness, but also as a function of the number of wash cycles executed (should each wash cycle of the machine foresee a constant water consumption) or of the water volumes totally softened in time, cycle by cycle.

Claims

1. Arrangement for the regeneration of the water softening resins in a washing machine, said arrangement comprising
 - a container (R) for the resins used to reduce the degree of water hardness,
 - a container (S) for the salt required for the resins regeneration.
 - metering means (E.V.) for the water to be delivered to the salt container (S) to execute said regenerations, where the resins regeneration processes are carried out periodically in time, in particular at each wash cycle executed by the machine, characterized in that the arrangement further provides sensor means (A,B,C,Q,MP) of the hardness of the water from the mains and an electronic control unit (MP) fit to evaluate the optimal volume of water to be used for the regeneration steps in function of the degree of water hardness detected by said sensor means (A,B,C,Q,MP) and consequently control said metering means (E.V.).
2. Arrangement, according to Claim 1, characterized in that the control unit (MP) is associated with non-volatile memory means (ROM), containing codified experimental data, which represent the volume of water to be delivered to the salt container (S) for the

- optimal resins regeneration, for each value of water hardness detected by said sensor means (A,B,C,Q,MP), included in a preset range of values.
3. Arrangement, according to Claim 1, characterized in that said metering means for the regeneration water comprise an intercepting device (E.V.) of a water flow (AR) to the salt compartment (S), controlled by said control unit (MP), where said nonvolatile memory means (ROM) contain codified experimental data, which indicate the opening times of said intercepting device (E.V.) for each value of water hardness detected by said sensor means (A,B,C,Q,MP), included in a preset range of values. 5
 4. Arrangement, according to Claim 1, characterized in that means (G) are provided to detect the salt presence in the relevant container (S) and means (L) to signal the need of salt filling, when a minimum preset level in the compartment (S) is reached, where said detecting means comprise said sensor means (A,B,C,Q,MP) of the degree of water hardness and said control unit (MP), which evaluates, the salt consumption in function of the hardness degree of water from the mains and activates said means, if required, to signal (L) when the evaluated salt level reaches a preset threshold. 10
 5. Arrangement, according to at least one of the previous Claims, characterized in that said nonvolatile memory means (ROM) contain codified experimental data representing the quantity of salt consumed during each resis regeneration process in function of the values of water hardness detected by said sensor (A,B,C,Q,MP), included in a preset range of values. 15
 6. Arrangement, according to Claim 5, characterized in that said nonvolatile memory means (ROM) contain codified experimental data representing the quantity of salt consumed during each regeneration process also in function of the volumes of softened water and/or of the volumes of water used for the regeneration. 20
 7. Arrangement, according to at least one of the previous Claims, characterized in that said sensor comprises means to detect the degree of water resistivity, from which the control unit (MP) is able to detect the value of water hardness from the mains. 25
 8. Arrangement, according to at least one of the previous Claims, characterized in that control means (G) are provided to inform the control unit that filling of said second medium in the relevant compartment (S) has occurred. 30
 9. Control method for resins regeneration in a water softening system of a washing machine, said system comprising a resin container (R) and a salt tank (S), where said resins have to be periodically submitted to a regeneration process through a water and salt solution produced in said tank (S), characterized in that the volume of water to be delivered to the salt tank (S) to produce the volume of water and salt solution to be transferred to the resin compartment (R) for the resins regeneration is variable in time and is calculated by a control unit (MP) during the wash cycles as a function of the degree of water hardness used for washing. 35
 10. Method, according to Claim 9, characterized in that the value of the water volume to be delivered to the salt tank (S) is also calculated as a function of the volume of softened water in time by the resins and/or of the number of regeneration cycles executed. 40
 11. Method, according at least to one of the previous Claims, characterized in that a complete regeneration step is periodically provided, during which the salt tank (S) receives the highest volume of water foreseen, whereby the intervals of said complete regeneration depend on the degree of water hardness and on the volume of softened water by the resins starting from the last complete regeneration executed. 45
 12. Method, according at least to one of the previous Claims, characterized in that the salt consumption value, or its concentration degree in the relevant tank, is evaluated by said control unit (MP) in time and updated during each wash programme, as a function of the water hardness from the mains. 50
 13. Method, according to the previous Claim, characterized in that signal means (L) are activated upon reaching a preset concentration degree or salt consumption value. 55
 14. Method, according to Claim 12, characterized in that a new evaluation cycle of the consumption or concentration degree will start when the control unit (MP) receives an information indicating that at least a certain quantity of new salt has been introduced in the relevant tank.
 15. Method, according to the previous Claim, characterized in that the salt consumption and/or its concentration degree is also evaluated as a function of the number and/or modality with which the wash cycles or regeneration processes are executed.

FIG. 1

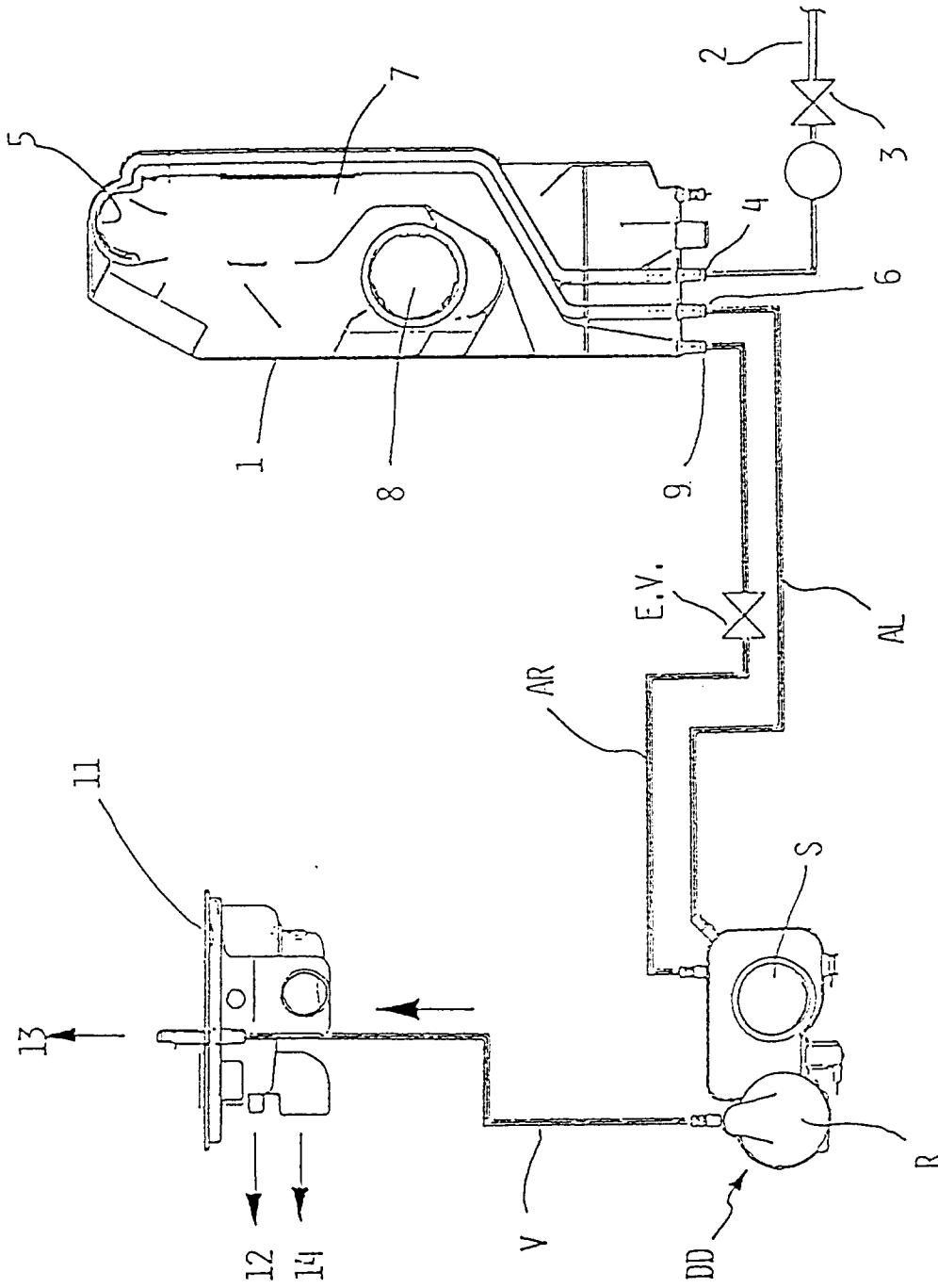

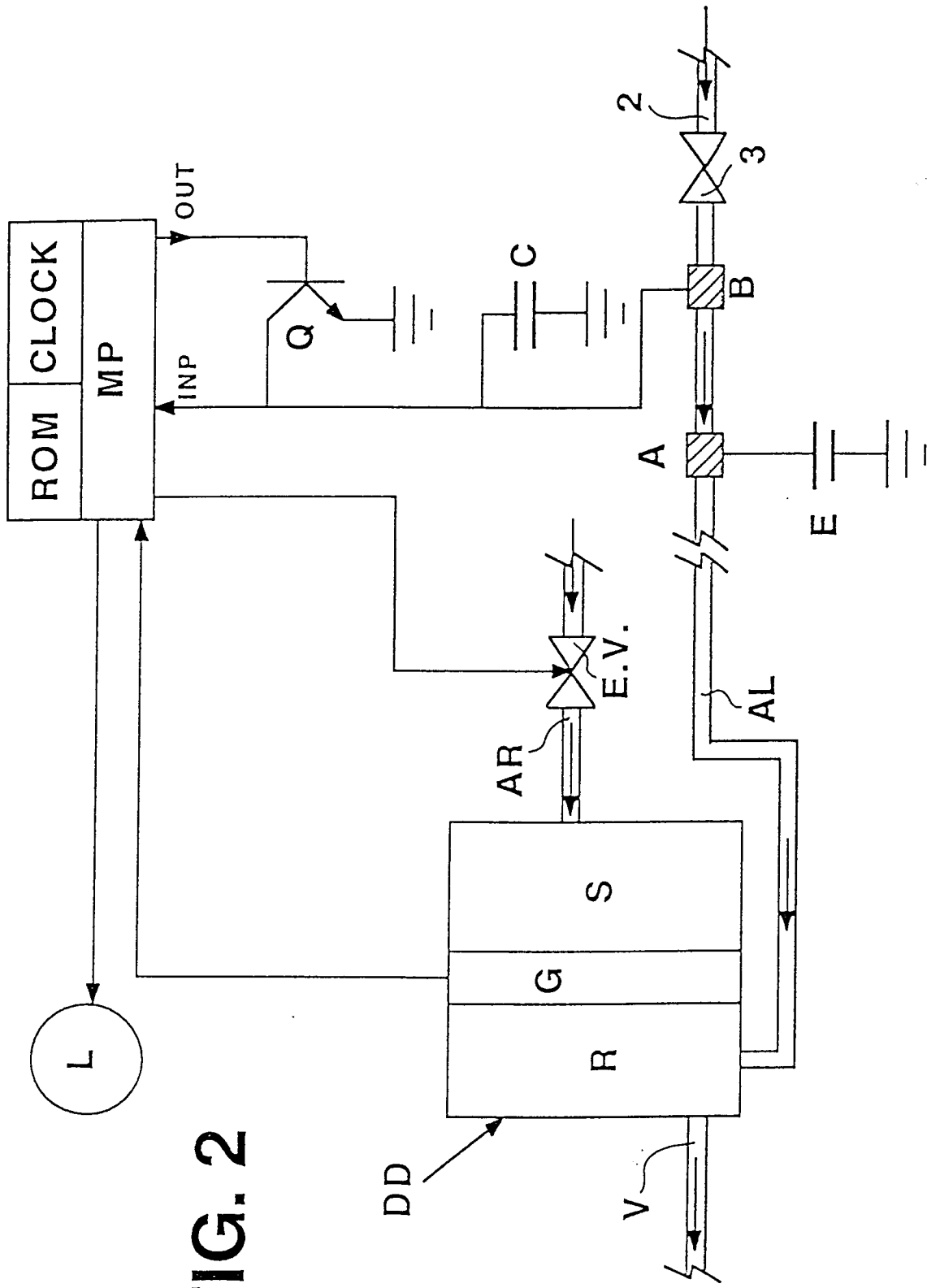

FIG. 2

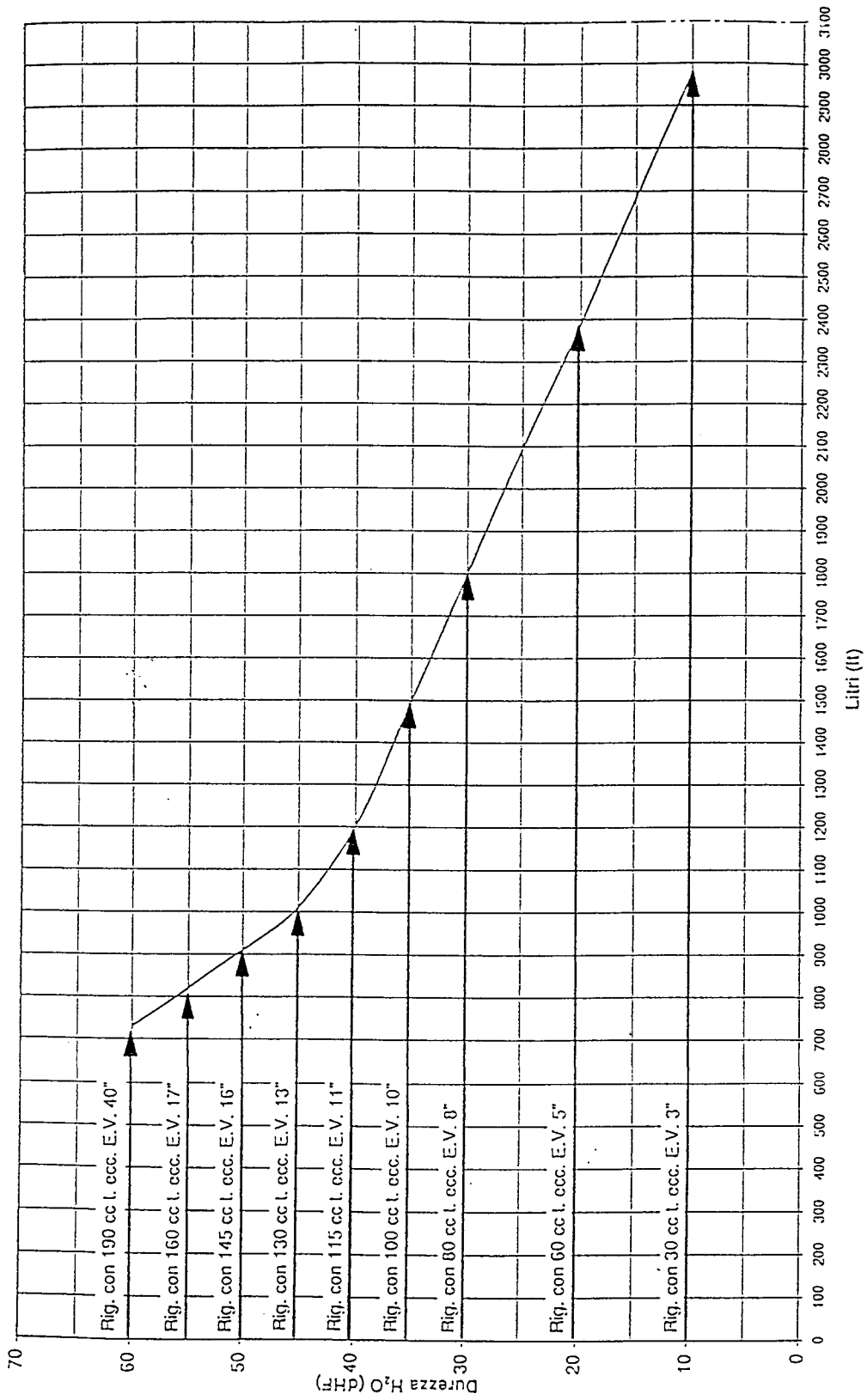

FIG. 3

European Patent
Office

EUROPEAN SEARCH REPORT

Application Number
EP 96 10 7251

DOCUMENTS CONSIDERED TO BE RELEVANT			
Category	Citation of document with indication, where appropriate, of relevant passages	Relevant to claim	CLASSIFICATION OF THE APPLICATION (Int.Cl.6)
Y	US-A-4 275 448 (G. LE DALL) * column 3, line 50 - column 18, line 37; figures *	1-15	A47L15/42
D,Y	--- EP-A-0 435 119 (MERLONI ELETTRODOMESTICI SPA) * column 1, line 42 - column 2; figure 1 *	1-15	
A	--- US-A-4 237 538 (G. LE GALL) * column 2, line 44 - column 9, line 47; figures *	1-15	
A	--- EP-A-0 425 815 (MERLONI ELETTRODOMESTICI SPA) * abstract *	1,2,9	
A	--- EP-A-0 496 957 (ZANUSSI ELETTRODOMESTICI SPA) * column 2, line 8 - column 5, line 49; figures *	1,9	
A	--- EP-A-0 249 000 (INDUSTRIE ZANUSSI SPA) * page 3, line 4 - page 6; figures *	1,9	
The present search report has been drawn up for all claims			TECHNICAL FIELDS SEARCHED (Int.Cl.6) A47L
Place of search THE HAGUE		Date of completion of the search 7 August 1996	Examiner Vanmol, M
CATEGORY OF CITED DOCUMENTS X : particularly relevant if taken alone Y : particularly relevant if combined with another document of the same category A : technological background O : non-written disclosure P : intermediate document T : theory or principle underlying the invention E : earlier patent document, but published on, or after the filing date D : document cited in the application L : document cited for other reasons & : member of the same patent family, corresponding document			

EPO FORM 1503 03.82 (P04C01)