



Europäisches Patentamt
European Patent Office
Office européen des brevets



(11) **EP 0 744 291 B1**

(12) **EUROPEAN PATENT SPECIFICATION**

(45) Date of publication and mention
of the grant of the patent:
12.07.2000 Bulletin 2000/28

(51) Int Cl.7: **B41J 2/085**

(21) Application number: **96303398.0**

(22) Date of filing: **14.05.1996**

(54) **Charge plate fabrication process**

Verfahren zur Herstellung von Ladungselektroden

Procédé de fabrication d'électrodes de charge

(84) Designated Contracting States:
DE FR GB

(30) Priority: **26.05.1995 US 451232**

(43) Date of publication of application:
27.11.1996 Bulletin 1996/48

(73) Proprietor: **Scitex Digital Printing, Inc.**
Dayton, Ohio 45420-4099 (US)

(72) Inventors:

- **Stephens, David**
Springboro, Ohio 45066-9540 (US)
- **Morris, Brian**
Dayton, Ohio 45419-2556 (US)
- **Tank, Peter**
Centerville, Ohio 45459-5147 (US)

(74) Representative: **Hillier, Peter et al**
Reginald W. Barker & Co.,
Cliffords Inn
Fetter Lane
London EC4A 1BY (GB)

(56) References cited:

EP-A- 0 132 972 **EP-A- 0 562 308**
EP-A- 0 613 778 **US-A- 4 223 321**
US-A- 4 622 562

- **ANONYMOUS: "SHORT-PROOF RESISTIVE CHARGE PLATE" RESEARCH DISCLOSURE, no. 304, 1 August 1989, NEW YORK, US, page 607 XP000070122**
- **PEEKEMA, R.M.: "CHARGE PLATE PASSIVATION PROCESS" IBM TECHNICAL DISCLOSURE BULLETIN., vol. 20, no. 11b, April 1978, NEW YORK US, page 4923 XP002050869**

EP 0 744 291 B1

Note: Within nine months from the publication of the mention of the grant of the European patent, any person may give notice to the European Patent Office of opposition to the European patent granted. Notice of opposition shall be filed in a written reasoned statement. It shall not be deemed to have been filed until the opposition fee has been paid. (Art. 99(1) European Patent Convention).

Description

Technical Field

[0001] The present invention relates to binary continuous ink jet printers and, more particularly, to improved construction for the charge plate in such printers.

Background Art

[0002] In continuous ink jet printing, electrically conductive ink is supplied under pressure to a manifold region that distributes the ink to a plurality of orifices, typically arranged in a linear array(s). The ink discharges from the orifices in filaments which break into droplet streams. Individual droplet streams are selectively charged to substantially two levels in the region of the break off from the filaments and charged drops are deflected from their normal trajectories. Either the deflected drops or the undeflected drops are caught and recirculated, and the other drops are allowed to proceed to a print medium.

[0003] In binary continuous ink jet, ink drops are charged by a charge plate having a plurality of charging electrodes along one edge, and a corresponding plurality of connecting leads along one surface. The edge of the charge plate having the charging electrodes is placed in close proximity to the break off point of the ink jet filaments, and charge is applied to the leads to induce charges in the drops as they break off from the filaments.

[0004] In U.S. Patent No. 4,560,991, issued December 24, 1985, to W. Schutrum, one method of fabricating a charge plate is described. The charge plate taught by Schutrum is fabricated by electro-depositing the charging electrodes and leads on a flat sheet of etchable material, such as copper foil, to form a so-called "coupon." The coupon is bent in a jig at approximately a 90° angle. The leads are then bonded to a dielectric material, such as aluminum oxide, and then the etchable substrate is removed by chemical etching. Such a charge plate fabrication method is a "lead transfer" method, in which the formation of electrodes on an etchable substrate is required.

[0005] Another "lead transfer" charge plate fabrication method is described in commonly assigned US-A-5 512 117, issued April 18, 1994, which also requires the formation of electrodes on an etchable substrate. This electroformed coupon is then bent at approximately 90 degrees, bonded to a dielectric material, such as aluminum oxide, and then the etchable substrate is removed by chemical etching.

[0006] Unfortunately, several problems exist with prior art charge plate fabrication techniques, such as the complexity of fabrication stemming from the relatively large number of manufacturing steps required to make a usable charge plate, as well as the cost associated with these manufacturing steps. There is also a loss of precision related to the lead transfer process, as the

leads tend to move slightly when the substrate is etched away. As the spatial distance between jets is decreased, there is an increasing problem with connections to external circuitry. For example, standard electronic connection technology can make approximately 20 electrical connections per linear inch of connector. More exotic technology can make reliable connections at 100 connections per inch. It is desired to have several hundred charge leads per inch in a modern ink jet printer. Currently, this is accomplished by "fanning out" the leads from the front edge of the charge plate to a longer connection area in the part of the charge plate away from the ink jet process. For example, a one inch wide printhead with 300 jets per inch requires at least three inches of connector space which must be provided at the rear of the charge plate. It is seen that this results in a charge plate and an ink jet printhead which is much larger than the desired small size. Another problem with the current charge plate fabrication technology relates to condensation on the charge plate during the operation of the printhead. Since the charge plate operates in a 100% relative humidity environment, water tends to condense on the charge plate. To avoid this problem, a heater as taught in U. S. Patent No. 4,622,562 is employed to keep the charge plate slightly warmer than the surrounding environment. In the present art as taught in the Schutrum patent, 4,660,991, the catcher heater is an added component under the charge plate in the catcher. Fabrication of this added component into the printhead adds cost and complexity to the printhead. Finally, nickel is commonly used as the electroformed electrodes and as such, it is highly vulnerable to electrochemical etching during the operation of the printhead during the ink jet printing process. This is especially true of the bottom portion of the leads, those furthest from the 90° bend where ink tends to accumulate during the ink jet printing process.

[0007] It is seen then that there exists a need for an improved charge plate fabrication which overcomes the problems associated with the prior art.

Summary of the Invention

[0008] This need is met by the integrated charge plate and electronic driver fabrication process according to the present invention, wherein the charge plate fabrication technique allows for fabrication by conventional methods, such as thin film and thick film patterning, and integration of the driver electronics onto the charge plate. Past efforts to utilize these methods failed for several reasons. First, electronic driver chips which could withstand the high voltages required for the ink jet process were not available. Second, processes to make the circuitry required on the charge plate were not available at the spatial resolution required. Finally, the techniques required for making a charge lead which extended around a 90° angle were not available due to the inability to pattern over an edge. Although a chip-on-charge

plate could be fabricated using the lead transfer method, this approach has limitations.

[0009] The present invention overcomes previous failures because in the subject method the patterning of the top and the edge are separated, which allows for more flexibility in manufacturing. A clever combination of new technologies allows fabrication of circuitry on the rear of the charge plate so that electronic chips to drive the charge leads can be mounted on the charge plate. This allows input to the charge plate over an electronic "bus" so that many charge leads can be driven from a few interconnections to external circuitry. The new technologies also allow integration of the charge plate heater onto the bottom of the charge plate. In addition, materials which are available for fabrication with the new techniques have a lower electrochemical etch rate.

[0010] In accordance with one aspect of the present invention, a method of fabricating a charge plate for an ink jet printer allows for fabrication by conventional methods. Initially, a ceramic charge plate substrate is provided, the substrate having an edge, a bottom and a top. The substrate is then edge printed to define a charging face on the edge of the ceramic charge plate substrate. The conductive path from the charging face to the top of the ceramic charge plate substrate is completed by top printing on the top surface to define a wrap around circuit. Part of the top circuit is patterning for the site on which the driver electronic chips will reside. In this case, the pattern consists of a number of small rectangular conducting areas or "pads" which surround the driver chip. The pads provide points to which connections can be made from the charge plate to the driver chip using suitable techniques which are known in the art, such as conventional wire bonding techniques, including gold wire ball bonding; flip chip attachment; ball grid array attachment, including micro ball grid array attachment; and tape automated bonding. Connections from the pads to the charging face and to the rear of the chip are also fabricated in this top patterning step. This patterning can be accomplished by any suitable method such as by a thick film process. The charge plate can be top patterned to connect top electrical connections to the front edge for charging and deflecting. When the conductive paths on the top of the ceramic charge plate substrate are completed, a second set of processes are used to form a region for two layer circuitry at the rear of the charge plate. For example, there is a need for an electrical grounding beneath the electrical traces bringing power and logic signals into the driver chips. Via holes through the charge plate are also fabricated so that thick film circuit technology can be used to create a resistive charge plate heater on the bottom of the charge plate.

[0011] Accordingly, it is an object of the present invention to provide a charge plate wherein inclusion of driver chips reduces the size of the interconnect. It is also an object of the present invention to provide a charge plate wherein fabrication by conventional methods, such as

thick film and thin film patterning, is allowed. It is a further object of the present invention to provide such a charge plate fabrication method which overcomes previous attempts at similar fabrication by separating the patterning of the top and the edge, or front face, of the charge plate. It is a further object to use thick film circuit technology to create a connection for a standard connector on the back edge of the charge plate, to provide circuitry required for electrical isolation of the drive chip. It is a further object to integrate a resistive charge plate heater onto the bottom of the charge plate. Finally, it is an object of the present invention to allow for more flexibility in manufacturing.

[0012] Other objects and advantages of the invention will be apparent from the following description, the accompanying drawings and the appended claims.

Brief Description of the Drawings

[0013]

Fig. 1 is a perspective view of a charge plate substrate;

Fig. 2 is a perspective view of a ceramic substrate, edge printed in accordance with the present invention;

Fig. 3 is a perspective view illustrating a wrap around conductive path on the edge printed substrate of Fig. 2;

Fig. 4 is a perspective view illustrating top patterning of the view in Fig. 3;

Fig. 5 is an exploded view illustrating the layers of the charge plate fabricated in accordance with the present invention; and

Fig. 6 is a block diagram illustrating the power, ground, control and data interfaces to the charge plate of Fig. 1.

Detailed Description of the Preferred Embodiments

[0014] Referring to the drawings, a charge plate substrate 10 of Fig. 1, capable of being assembled into a charge plate assembly, is illustrated. The charge plate substrate 10 is preferably ceramic and fabricated from 96% aluminum oxide having a coefficient of thermal expansion (CTE) of $8.2 \times 10^{-6}/^{\circ}\text{C}$. A front edge 12 is substantially perpendicular with a top surface 14. The front surface is preferably flat to provide optimum charge.

[0015] Referring now to Fig. 2, initially the ceramic substrate 10 of Fig. 1 is edge printed on its front edge 12 to define charge surfaces or charging face 16. In a preferred embodiment of the present invention, the height of the front edge 12 is approximately 0.015 inches. The front edge 12 is substantially perpendicular to bottom surface 18. Chamfer 20 separates the front edge 12 and the bottom surface 18 with an approximately 45° surface, to provide clearance for drops deflected to the catcher.

[0016] In a preferred embodiment of the present invention, during edge print a small amount of ink can be purposely allowed to extend over to the top surface for improved electrical connection. The charge surfaces 16 are defined by passing thick film conductive ink through an opening in a screen, i.e., silk screen printing, and/or thin metal foil, i.e., stencil printing, using standard processes in the thick film processing art. Silk screening has the advantage of allowing for the creation of unusual patterns; while stenciling has the advantage of providing improved quality of printed lines and spaces without the wire mesh which can create problems when pushing ink through at high resolutions. A gold thick film paste, such as commercially available DuPont 5715 Gold Thick Film Paste, is preferable over nickel because gold is more chemically inert than nickel.

[0017] Referring now to Fig. 3, subsequent to defining the charge surfaces 16, a conductive path is continued to top surface 14, to create a wrap around conductive path 22. During wrap around, in a preferred embodiment of the present invention, these lines can be permitted to extend over the front edge. This creates an overlap from both the edge and the wrap around print that ensures good electrical connection around the edge.

[0018] The wrap around 22 is also defined by thick film paste or printing techniques, such as printing, drying and firing steps. Hence, the present invention applies thick film processing to make the electrical connection between the top surface 14 and the charging face 16. Electrical connection from top surface 14 to the front surface 12 is achieved using the electrical connection wrap around process, which connects the front face electrical connections 16 to top electrical connections 22. This involves direct metal to metal diffusion during the step of firing, prior to the step of top patterning, and following the steps of printing and drying, of the substrate.

[0019] Referring now to Fig. 4, top patterning 24 of the substrate is illustrated, subsequent to the steps of printing, drying, firing, and metal to metal diffusion, to create a charge plate. Top patterning of the substrate can be by any suitable means, such as use of Fodel photoimageable materials as described in Proceedings of the 1993 International Symposium On Microelectronics. Fodel technology is an extension of thick film paste technology, developed by combining inorganic components, metal powders, glass powders, metal oxides and refractory powders, used to make thick film dielectrics and conductors with the organic components, polymers, photoinitiators, monomers and stabilizers, used to make photoresist films for the printed wiring board industry. This combination results in photoimageable ceramic material that combines the well known reliability of ceramic materials with the ease of processing in conventional equipment, using mild aqueous chemistries, currently used in the printed wiring board industry.

[0020] The Fodel process, like the component materials, is a combination of the conventional thick film and printed wiring board processes. As will be obvious to

those skilled in the art, conventional thick or thin film processes and convention printed circuit board processes can be used independently or in any suitable combination to achieve the patterning of the charge plate of the present invention. The Fodel process is described herein for purposes of example only, and is not to be considered as limiting the invention.

[0021] The Fodel process begins with the application of a photoactive paste, such as a commercially available Fodel paste, to the desired substrate by blank screen printing. The paste is allowed to level at room temperature and is then dried, for example at a temperature of 80°C. After drying, the paste is exposed in UV light (with a typical maximum wavelength of approximately 360 nm) through the appropriate photomask to form a latent image. Following exposure, the latent image in the materials is developed such as in a conveyORIZED, spray processor, for example using 1% aqueous Na₂CO₃ solution. The developed paste is then fired by conventional thick film methods.

[0022] After the top patterning process illustrated in Fig. 4, the top patterned surface is coated with a material that has a high breakdown voltage and is pinhole free. A preferred material is a dielectric material which sinters to the top patterned surface to make a good dielectric coating. The dielectric coating may be any suitable dielectric such as commercially available DuPont 5704 Dielectric.

[0023] As is well known in the art, thick film technology is a method for producing patterned circuitry used in the electronics industry. The pattern is silkscreened onto a substrate, then dried and fired. The process starts with a suitable substrate that can withstand the temperatures that are necessary to sinter or "fire" the inks, such as a substrate comprising 96% aluminum oxide. Thick film inks are then silkscreened onto the substrate. Of course, various inks are available for different applications. For example, certain conductive inks can be used to form conductive gold traces; a conductive ink that contains palladium-gold can be used as solderable points; a more resistive type of ink could be used to form resistive elements for an electronic circuit or perhaps a resistive type heater; a non-conductive or dielectric ink can be printed to provide a protective coating over a previously formed circuit or a barrier between two circuit layers. These inks mainly consist of three primary elements, including a binder constituent (referred to as frit), a print vehicle and a functional constituent. Once the ink is silkscreened onto the substrate it is sent through a drying furnace where the temperature reaches approximately, for example, 150°C, for the purpose of evaporating all solvents. The next step is to fire the printed and dried substrate. The part is subjected to a specific temperature profile where the part is raised to and dwells at a temperature where all organic matter is burned off, for example, 500°C. The part is then subjected to a temperature where firing actually takes place, such as 850°C. At 850°C the functional constituent is sintered

into a layer of functional material. Likewise, the frit sinters and partially diffuses into the substrate, thus providing a means to adhere the functional constituent to the substrate. Finally, the temperature is lowered. Additional layers can be placed on top of each other and would follow the same process.

[0024] Referring now to Fig. 5, ceramic substrate layer 26 is edge printed with edge print layer 28, such as a gold thick film. A wrap around layer 30 is then applied, which may be any suitable material such as gold thick film. A fine line circuitry layer 32 is formed using the Fodel process. This layer provides a connecting path between charge driver chips 34 and charge electrodes on edge print 28. A ground plane circuitry 36 is then applied to provide an electrical ground path between the connector 38 and the driver chips 34. These two separate layers are then coated with a dielectric layer 40 which sinters to the top of the patterned surfaces and makes a good electrically insulated coating. The control circuitry layer 42 provides a path for power, control and data signals between the connector 38 and the driver chips 34.

[0025] Referring now to Fig. 6, there is illustrated a block diagram showing the functional relationships between the various layers on the charge plate and connection to supporting electronics remote from the charge plate. In Fig. 6, power, control and data lines 44, 46, 48, respectively, are connected to power supplies 50, print controller 52 and print data generator 54, respectively, through the connector 38.

[0026] Referring back to Fig. 5, a second dielectric coating 56 is applied to protect the control circuitry as well as to provide a second coating over the fine line circuitry 32. It is important that the dielectric coating be free of voids in the area of the fine line circuitry. Otherwise, conductive ink used in the ink-jet printing process could provide a conductive path between two adjacent traces and cause an electrical short which could lead to component failure.

[0027] Continuing with Figs. 5 and 6, the driver chips 34 are silicon devices that accept logic level data in a serial fashion, then latch those signals and output the same data in parallel, but with much higher voltage potential. Logic levels are typically 0 and 12 volts dc. The output voltages can range from 60 to 180 volts dc. The input channels of the driver chips 34 are connected to the ground plane 36 and the control circuitry 42 by suitable means such as gold wire ball bonding. The output channels of the driver chips 34 are connected to the fine line circuitry 32, also by suitable means such as gold wire ball bonding. An epoxy or other suitable material is used to cover the chips and the wire bonds, to protect the chips and wire bonds from the environment.

[0028] Continuing with Figs. 5 and 6, connector 38 is applied through standard surface mount soldering techniques. A solderable metal layer provides pads where the connector is soldered on, and small holes in the back are plated through to create conductive vias from the top surface to the bottom surface. This provides an elec-

trical path from the top to the bottom of the charge plate, and to a resistive charge plate heater. The resistive charge plate heater, comprised of resistive layer 58 and heater circuit layer 60, is integrated onto the bottom surface also using thick film technology. The heater circuit 60 is applied using the solderable ink and provide, the conductive path between the vias and the heater layer 58. The heater layer 58 is then applied using resistive inks. The shape and thickness of this layer determines the resistance desired.

[0029] The top patterned fine line circuitry layer 32 provides the conductive path between the wrap around pattern and the output of the driver chip. This layer includes pads used in the wire bonding operation. Ground plane circuitry layer 36 provides a conductive path for the ground signals between the driver chips and a surface mount connector. The top patterned surface is coated with dielectric layer 40 which sinters to the top patterned surface to make a good dielectric coating. Control circuitry layer 42 provides a conductive path between the connector and driver chips before second dielectric layer 56 is applied. Charge driver components indicated as layer 34 and surface mounted connector 38 provide a connection between the controller and data source. A resistive charge plate heater, comprised of resistor layer 58 and heater circuitry layer 60, is integrated onto the bottom of the charge plate, indicated as reference number 62 in Fig. 6.

[0030] Separating the patterning of the top surface and the front surface, in accordance with the present invention, allows for more flexibility in manufacturing, in that it allows different materials to be used. As will be obvious to those skilled in the art, changing the material of the charge surfaces changes the electrical properties. With the present invention, different materials can be selected to achieve the overall desired electrical and electro-chemical properties.

Industrial Applicability and Advantages

[0031] The present invention is useful in the field of ink jet printing, and has the advantage of allowing for direct formation of a charge face. This provides the advantage of simplification of charge plate fabrication. Once the wrap around is complete, top patterning of the charge plate can be achieved by a variety of techniques such as etchable thick film process, traditional thin film process, hybridization of thick and thin film processes, and photoimageable thick film techniques. The inclusion of driver chips provides the advantage of reducing the size of the interconnect.

[0032] Having described the invention in detail and by reference to the preferred embodiment thereof, it will be apparent that other modifications and variations are possible without departing from the scope of the invention defined in the appended claims.

Claims

1. A method of fabricating a charge plate for an ink jet printer comprising the steps of:
 - a. providing a ceramic charge plate substrate having an edge, a top, and a bottom;
 - b. edge printing the ceramic charge plate substrate to define a charging face on the edge of the ceramic charge plate substrate;
 - c. completing a conductive path from the charging face to the top of the ceramic charge plate substrate to create a charge plate;
 - d. providing charge drivers on the charge plate top surface;
 - e. top patterning the charge plate to allow an electrical connection from the charge drivers to the charge plate; and
 - f. coating the top patterned surface with a dielectric material.
2. A method of fabricating a charge plate as claimed in claim 1 further comprising the step of completing a conductive path from the top surface to the bottom surface through conductive vias.
3. A method of fabricating a charge plate as claimed in claim 1 further comprising the step of patterning the bottom surface to allow for a resistive catcher heater.
4. A method of fabricating a charge plate as claimed in claim 1 further comprising the step of providing a connector for control signals.
5. A method of fabricating a charge plate as claimed in claim 4 further comprising the step of providing a conductive path from the charge drivers to the connector.
6. A method of fabricating a charge plate as claimed in claim 1 further comprising the step of providing electrical connections from the charge plate to the charge drivers by gold wire ball bonding.
7. A method of fabricating a charge plate as claimed in claim 1 wherein the ceramic charge plate substrate comprises 96% aluminum oxide.
8. A method of fabricating a charge plate as claimed in claim 1 further comprising the step of forming electrodes on an etchable substrate associated with the ceramic charge plate substrate.
9. A method of fabricating a charge plate as claimed in claim 1 further comprising the step of providing a chamfer to separate the edge and the bottom.

10. A method of fabricating a charge plate as claimed in claim 9 wherein the chamfer comprises a non-conductive surface.

Patentansprüche

1. Verfahren zum Herstellen einer Ladungsplatte für einen Tintenstrahldrucker, welches die folgenden Schritte enthält:
 - a. Bereitstellen eines keramischen Ladungsplattensubstrats mit einem Rand, einer Ober- und einer Unterseite,
 - b. Bedrucken des Randes des keramischen Ladungsplattensubstrats, um eine Ladungsfläche auf dem Rand des keramischen Ladungsplattensubstrats zu bilden,
 - c. Vervollständigen eines Leitweges von der Ladungsfläche zu der Oberseite des keramischen Ladungsplattensubstrats, um eine Ladungsplatte zu erzeugen,
 - d. Bereitstellen von Ladungstreibern auf der oberen Fläche der Ladungsplatte,
 - e. Aufbringen eines Musters auf der Oberseite der Ladungsplatte, um eine elektrische Verbindung von den Ladungstreibern zu der Ladungsplatte zu ermöglichen, und
 - f. Beschichten der mit einem Muster versehenen oberen Fläche mit einem dielektrischen Material.
2. Verfahren zum Herstellen einer Ladungsplatte nach Anspruch 1, weiterhin enthaltend den Schritt des Vervollständigens eines Leitweges von der oberen Fläche über Leitverbindungen zu der unteren Fläche.
3. Verfahren zum Herstellen einer Ladungsplatte nach Anspruch 1, weiterhin enthaltend den Schritt des Aufbringens eines Musters auf der unteren Fläche, um eine Widerstandsheizung für die Fangeinrichtung zu ermöglichen.
4. Verfahren zum Herstellen einer Ladungsplatte nach Anspruch 1, weiterhin enthaltend den Schritt des Bereitstellens einer Verbindungseinrichtung für Steuersignale.
5. Verfahren zum Herstellen einer Ladungsplatte nach Anspruch 4, weiterhin enthaltend den Schritt des Bereitstellens eines Leitweges von den Ladungstreibern zu der Verbindungseinrichtung.
6. Verfahren zum Herstellen einer Ladungsplatte nach Anspruch 1,

weiterhin enthaltend den Schritt des Bereitstellens von elektrischen Verbindungen von der Ladungsplatte zu den Ladungstreibern durch Golddraht-Nagelkopfkontaktierung.

7. Verfahren zum Herstellen einer Ladungsplatte nach Anspruch 1, bei dem das keramische Ladungsplattensubstrat 96 % Aluminiumoxid enthält.
8. Verfahren zum Herstellen einer Ladungsplatte nach Anspruch 1, weiterhin enthaltend den Schritt des Bildens von Elektroden auf einem ätzbaren Substrat, welches zu dem keramischen Ladungsplattensubstrat gehört.
9. Verfahren zum Herstellen einer Ladungsplatte nach Anspruch 1, weiterhin enthaltend den Schritt des Bildens einer Fase, um den Rand und die untere Fläche voneinander zu trennen.
10. Verfahren zum Herstellen einer Ladungsplatte nach Anspruch 9, bei dem die Fase eine nicht leitfähige Fläche enthält.

Revendications

1. Procédé de fabrication d'une électrode de charge pour une imprimante à jet d'encre comprenant les étapes suivantes :
 - a) la prévision d'un substrat d'électrode de charge en céramique possédant un bord, un dessus et un dessous ;
 - b) l'impression de bord du substrat d'électrode de charge en céramique afin de définir une face de chargement sur le bord du substrat d'électrode de charge en céramique ;
 - c) la réalisation d'un circuit conducteur à partir de la face de chargement au sommet du substrat d'électrode de charge en céramique afin de créer une électrode de charge ;
 - d) la prévision de circuits d'attaque de chargement sur la surface supérieure d'électrode de charge ;
 - e) la formation de motif supérieur de l'électrode de charge pour permettre une connexion électrique des circuits d'attaque de chargement à l'électrode de charge ; et
 - f) le revêtement de la surface supérieure à motif à l'aide d'un matériau diélectrique.
2. Procédé de fabrication d'une électrode de charge selon la revendication 1, comprenant, de plus, l'éta-

pe de réalisation d'un circuit conducteur de la surface supérieure à la surface inférieure via des passages conducteurs.

3. Procédé de fabrication d'une électrode de charge selon la revendication 1, comprenant, de plus, l'étape de formation de motif sur la surface inférieure pour en déduire un chauffage de dispositif de saisie par résistance.
4. Procédé de fabrication d'une électrode de charge selon la revendication 1, comprenant, de plus, l'étape de prévision d'un connecteur pour des signaux de commande.
5. Procédé de fabrication d'une électrode de charge selon la revendication 4, comprenant, de plus, l'étape de prévision d'un circuit conducteur des circuits d'attaque de chargement au connecteur.
6. Procédé de fabrication d'une électrode de charge selon la revendication 1, comprenant, de plus, l'étape de prévision de connexions électriques de l'électrode de charge aux circuits d'attaque de chargement selon une liaison par billes à fil d'or.
7. Procédé de fabrication d'une électrode de charge selon la revendication 1, selon lequel le substrat d'électrode de charge en céramique comprend 96% d'oxyde d'aluminium.
8. Procédé de fabrication d'une électrode de charge selon la revendication 1, comprenant, de plus, l'étape de formation d'électrodes sur un substrat pouvant être gravé associé au substrat d'électrode de charge en céramique.
9. Procédé de fabrication d'une électrode de charge selon la revendication 1, comprenant, de plus, l'étape de prévision d'un chanfrein pour séparer le bord et le fond.
10. Procédé de fabrication d'une électrode de charge selon la revendication 9, selon lequel le chanfrein comprend une surface non conductrice.

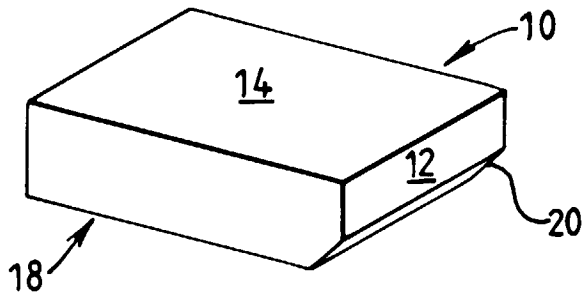

FIG. 1

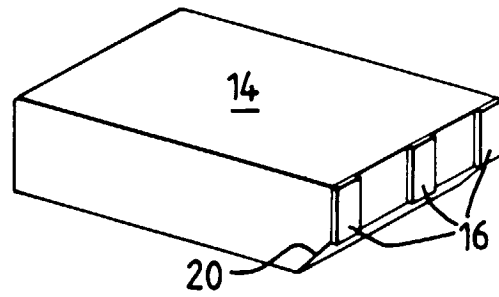

FIG. 2

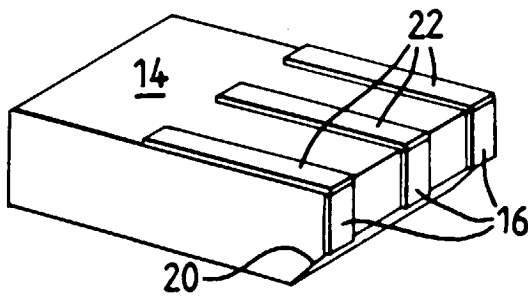

FIG. 3

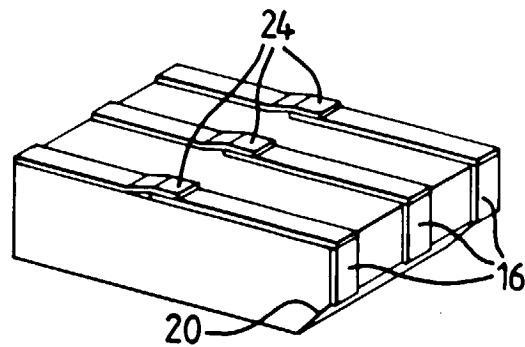

FIG. 4

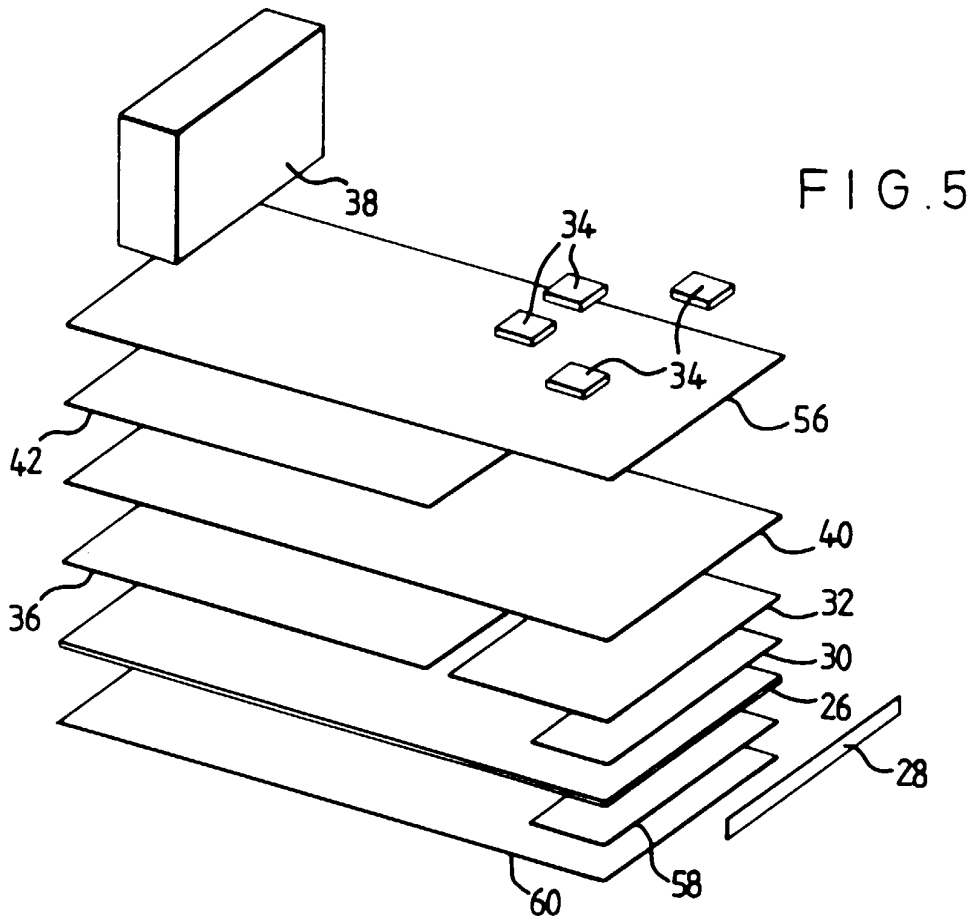

FIG. 5

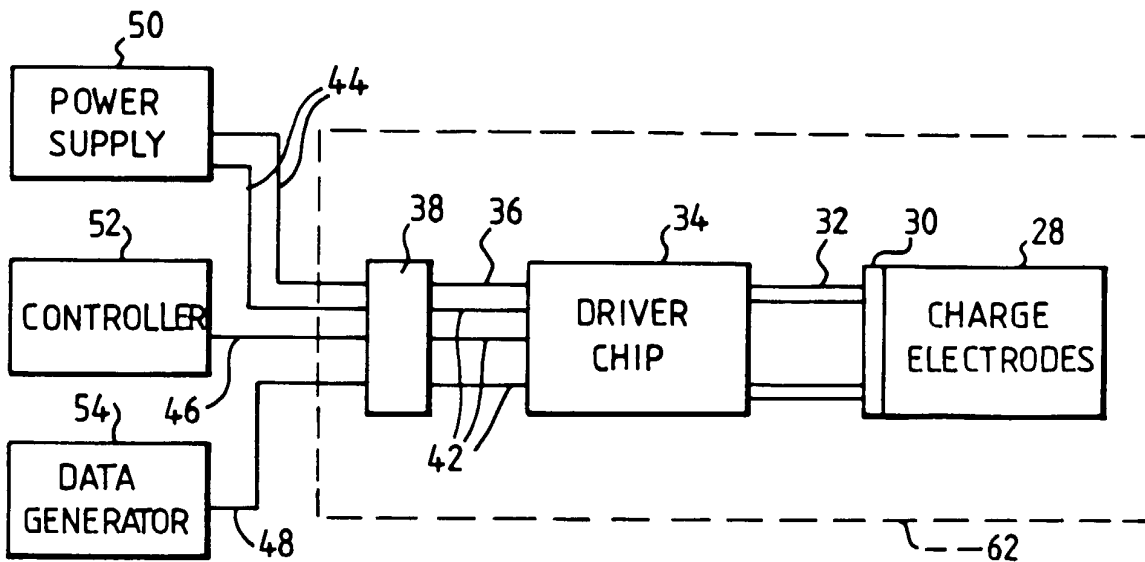

FIG. 6