

(19)



Europäisches Patentamt
European Patent Office
Office européen des brevets



(11)

EP 0 747 916 B1

(12)

EUROPEAN PATENT SPECIFICATION

(45) Date of publication and mention
of the grant of the patent:
27.10.1999 Bulletin 1999/43

(51) Int Cl.⁶: **H01H 23/14, H01H 23/04**

(21) Application number: **96201441.1**

(22) Date of filing: **23.05.1996**

(54) **A sectional structure for electrical devices, with a support fitting for a switch button**

Zusammensetzbare Struktur für elektrische Vorrichtung, mit Halterung für Kipphebel

Structure à sections pour dispositifs électriques, avec support pour bascule de commande

(84) Designated Contracting States:
BE DE ES FR GB

(72) Inventor: **Fabrizi, Fabrizio**
24100 Bergamo (IT)

(30) Priority: **29.05.1995 IT MI951111**

(74) Representative: **Maggioni, Claudio et al**
c/o JACOBACCI & PERANI S.p.A.
Via Visconti di Modrone, 7
20122 Milano (IT)

(43) Date of publication of application:
11.12.1996 Bulletin 1996/50

(73) Proprietor: **BTICINO S.P.A.**
20154 Milano (IT)

(56) References cited:
AU-A- 3 454 889 **DE-U- 9 218 404**
US-A- 3 254 191 **US-A- 4 429 200**
US-A- 5 213 204

EP 0 747 916 B1

Note: Within nine months from the publication of the mention of the grant of the European patent, any person may give notice to the European Patent Office of opposition to the European patent granted. Notice of opposition shall be filed in a written reasoned statement. It shall not be deemed to have been filed until the opposition fee has been paid. (Art. 99(1) European Patent Convention).

Description

[0001] The subject of the present invention is a switching device according to the preamble of claim 1, as for example known from AU-B-3454889.

[0002] The structures referred to herein are well known in the field of electrical systems for domestic environments and the like. In fact, as is known, most electrical devices commonly found in dwellings nowadays are fitted in corresponding sectional structures of the type referred to above; this sectional arrangement is intended to enable various devices to be mounted interchangeably in the same structure, thus providing sets of coordinated products, which can achieve considerable advantages from both the production and the commercial points of view. For greater clarity, the case of the switches which are commonly found in dwellings may be considered: these usually have frames fixed to the wall, similar to those also used for wall sockets; in fact, these frames are generally produced in standard shapes and sizes so that their seats can house the bodies of the switches or those of the socket contacts interchangeably.

[0003] Before the description is continued, it should be also pointed out that the expression switching device or, more simply, switch is intended to indicate generally two types of electrical device: simple, single-pole, contact-breaking switches also known by the acronym SPST (single pole-single throw) and single-pole, contact-switching switches also known by the acronym SP-DT (single pole-double throw).

[0004] It is also appropriate to point out that the definition electrical device should be understood in a broad meaning which includes, in addition to the switches already mentioned, wall sockets, push-buttons, key-boards and knobs for various applications such as the usual bells, thermostatic regulators or timing devices, light or sound indicators for alarm systems and the like, fuses, sockets for television aerials or for the connection of coaxial cables of other kinds, as well as anything else which may be used in electrical systems.

[0005] The range of coordinated products belonging to the same set mentioned above is generally quite large in order to meet customers' requirements; for example, sets of products in which the structures have cover plates with various colours or the seats for housing the devices have dimensions such as to enable a different number of devices to be fitted according to need are currently on the market.

[0006] It is clearly not expedient, however, to have too great a variety in the product range in view of the costs as well as production and industrial difficulties in general which would otherwise arise; for example, it should be borne in mind that most parts of the sectional structures can be made of plastics material and additional moulds and operations, with all of the related expenditure of resources which may result therefrom, are therefore necessary for each differentiation introduced.

[0007] Sometimes, however, practical considerations nevertheless require equivalent products belonging to the same set to be differentiated; for example, this is the case for products intended for export to various countries. In fact, it is not rare for the technical standards or the customers' tastes to differ slightly, in similar circumstances, from nation to nation, thus creating the need to introduce modifications to similar products intended for the various markets.

5
10
15
[0008] A typical example of this is represented by light-switch buttons; in some markets, particularly European markets, they are required to have larger dimensions than those in use in other countries. At the moment, in addition, of course, to the modification of the buttons themselves this involves, in practice, the need to introduce modifications to the switches, which results in the disadvantage of the need to differentiate between these products in batches intended for the various countries.

20
25
30
35
[0009] More particularly, a known solution for meeting this need consists of the formation of the body of the switch, which is the portion housing the electrical components (contacts, terminals, etc.), with larger dimensions so that it fits the larger button which is mounted thereon by a snap-engagement of known type. It should be pointed out that, in these devices, the aforementioned electrical components are nevertheless the same as those used in switches with standard dimensions and the space available inside the larger body is thus clearly underused; it should be pointed out that, in the prior art, according to a preferred embodiment, the body of the switch is formed with dimensions multiples of those corresponding to a normal device so that it can occupy a space corresponding to one or more devices in the seat of the frame in which it is housed, according to need.

40
45
50
[0010] It is clear from the foregoing that a solution of this type is certainly not optimal; in fact, as well as being larger than necessary in view of what was stressed above, the bodies of switches formed according to the known teaching cannot provide a modular response to the requirement already mentioned. In other words, the production of switch bodies with different dimensions according to those of the buttons itself involves an increase in the range of products to be produced which is contrary to the tendency to limit excessive proliferation of products within the same set; in fact, since it is clearly necessary to produce different buttons in any case, it would be expedient, in the light of the foregoing, at least to avoid the production of bodies provided specifically solely to fit these buttons, thus limiting the number of products to be manufactured for the same set.

55
[0011] The object of the invention is therefore to provide a switching device with a sectional structure for electrical devices of the type considered at the beginning of this description, in which it is possible to use buttons having various dimensions without the adverse consequences which arise in the prior art described above.

[0012] This object is achieved by a switching device with a sectional structure defined in the claims which follow this description.

[0013] For a better understanding of the invention, its further characteristics and of the advantages achieved thereby, an embodiment thereof is described below purely by way of non-limiting example, with reference to the appended drawings, in which:

Figure 1 is an exploded, axonometric view of the structure of the invention,

Figure 2 is an axonometric view of a button of a switch of the structure of Figure 1,

Figures 3 and 4 are sectioned side views of a detail of Figure 1, in respective operative conditions.

[0014] On the basis of the drawings summarized above, these show a structure according to the invention, generally indicated 1; this structure includes a frame 2 to be fixed on a wall and a cover plate 3 which is coupled to the frame by snap-engagement, in known manner. A switch 4 is housed in a seat 5 in the frame 2, to which it is fixed releasably by resilient engagement means of known type which are therefore not described in detail in this description; these means are, in any case, provided both in the seat and on the body 41 of the switch and are visible, although not numbered, in Figure 1.

[0015] As already stated, the switch 4 comprises a body 41 which houses its electrical elements (terminals, contacts etc.), not shown in the appended drawings, and a rocker element 42 which can perform a snap pivoting movement about an axis transverse the body; this rocker element is situated at the front of the body 41 when the body is fitted in the seat 5 in the frame, the rocker acting on the electrical elements in order to activate the electrical contacts of the switch.

[0016] At the same time, the rocker element also acts as means for the fixing of a switch button 50; more precisely, the button 50 just mentioned is fixed releasably to the rocker element 42 by the snap engagement of ribs 53 and 43 formed on a projecting rim 54 and on a partition 55 of the former (see Figure 2) as well as on the principal sides of the latter (see Figure 1), respectively.

[0017] With reference to Figure 2, it can in fact be seen that the face of the button 50 which faces towards the body of the switch is divided into two portions by the partition 55, the first portion being intended to be coupled frontally with the body 41 on the ribs thereof, whereas the latter has a bracket 56 which is intended to house a pin 61 of a fitting 60 for supporting the switch button. This fitting is essentially an element of a shape similar to that of the switch-body half, having the same resilient-engagement mounting means as the latter, and occupying the same space in the seat 5; the pin 61 mentioned above is formed in an opening 62 disposed at the apex

of a surface projection on the side of the fitting which faces towards the button 50 when the structure is in the assembled condition.

[0018] The pin 61 and the bracket 56 are in practice a hinge-like coupling which allows the button 50 to perform a rotary movement about the pin 61 (see Figures 3 and 4) but prevents relative translations which would move the button away from the fitting; moreover, by virtue of the resilience of the bracket which, like the cover 50, in a preferred embodiment, is made of plastics material, it is nevertheless possible to remove the button from the pin in order to disassemble the structure if necessary.

[0019] When the structure of the invention is in the assembled configuration, the fitting 60 and the switch 4 are mounted side by side in the seat 5 and the button 50 is engaged with the rocker element 42 to which it is fixed for the pivoting movement thereof; at the same time, the hinge-like coupling of the pin 61 with the bracket 56 provides a support for the button which is therefore supported in a balanced manner relative to the partition and can thus be pressed from the front at any point without danger of being detached from the rocker element.

[0020] It will also be noted that the hinge-like pin-bracket coupling does not obstruct the pivoting movement of the button together with the rocker element at this stage.

[0021] It can therefore be understood that the structure of the invention achieves the object set at the beginning since it permits the use of buttons with larger dimensions without the need for appropriate modification of the structure itself or of the normal switching devices but, on the contrary, achieves compatibility with those already existing. In the light of the foregoing description, it is in fact clear that a button 50 of any width larger than that of a normal switch, that is, a switch corresponding to the production standard may be selected, the switch nevertheless being able to be used as described in the example and thus mounted in a structure also of standard type; for this purpose, it is hardly necessary to indicate that it will be sufficient to ensure that the configuration defined by the partition 55 and by the projecting rim 54 of the lever 50 seen in the foregoing example, including the ribs 51, reproduces the shape of a standard button.

[0022] Thus, in summary, in order to fit a button with larger dimensions in the structure of the present invention, there is no need for modifications or alterations of the structure or for a specifically adapted switch body, but it is sufficient to provide for the use of the fitting 60; this can be mass produced preferably with the same dimensions as a device since it can thus occupy the same space in the mounting seat. It will also be noted that, if necessary, several fittings may be mounted in the same structure; in this connection, the case of a switch lever having a width equal to three or more electrical devices intended for the structure may be considered; it would certainly be advantageous to have at least two fittings

arranged in the seat in the frame, on opposite sides of a switch, both supporting the button which is engaged with the rocker element of the switch. In this case it would simply be necessary to provide two brackets and two partitions in the button instead of one of each as indicated in the foregoing example, forming a variant of the embodiment described above which would nevertheless fall within the teaching of the present invention as is clear from the description and the following claims.

Claims

1. Switching device with a sectional structure for the wall mounting of electrical devices, comprising a support frame (2) which is intended to be fixed to the wall and has a seat (5) for the mounting of the devices, the seat containing at least one switching device (4) having a body (41) housing its electrical contacts, a button (50) being associated with the body on the opposite side to that corresponding to the wall, and acting on the contacts by means of a pivoting movement, characterized in that said seat (5) is only partially occupied by the switching device (4) and in that a portion of the button (50) projects laterally from the body of the device into the portion of the seat (5) which is not occupied by the switching device, in said portion being removably inserted a fitting (60) which forms a hinge-like coupling with the projecting portion of the button (50) about an axis substantially parallel to that of the pivoting movement thereof.
2. Switching device with a sectional structure according to Claim 1, characterized in that the fitting has a body provided with resilient engagement means for its releasable mounting in the seat.
3. Switching device with a sectional structure according to Claim 2, characterized in that the resilient engagement means of the fitting are the same as those of the devices designed for the structure.
4. Switching device with a sectional structure according to any one of Claims 1 to 3, characterized in that the button (50) is fixed removably to a rocker element (42) which is mounted peripherally in the body of the switching device and can perform a pivoting movement.
5. Switching device with a sectional structure according to any one of Claims 1 to 4, characterized in that the fitting has a width equal to that of the devices designed for the structure.
6. Switching device with a sectional structure according to any one of Claims 1 to 5, characterized in that the portion of the body of the fitting (60) which is

disposed adjacent the button of the switch when the structure is in the assembled condition has a projection in which there is a hole (62) bearing a transverse pin (61).

7. Switching device with a sectional structure according to any one of Claims 2 to 6, characterized in that the button has a projecting rim (54) around its profile, as well as a partition (55) dividing the face of the lever which is intended to face the switch into at least two portions of which one has means (51) for engagement with the rocker element and the other, corresponding to the projecting portion of the button, has a bracket (56) which can house the pin of the fitting, forming the hinge-like coupling.
8. Switching device with a sectional structure according to any one of Claims 1 to 7, characterized in that the fitting and the button of the switch are formed of plastics material.
9. Switching device with a sectional structure according to any one of claims 1 to 8, wherein
 - the fitting (60) has a body provided with resilient engagement means for its releasable mounting in the seat (5), the portion of said body which is disposed adjacent the button of the switch when the structure is in the assembled position having a projection in which there is a hole (62) bearing a transverse pin (61), and
 - the button (50) has a projecting rim (54) around its profile, as well as a partition (55) dividing the face of the lever which is intended to face the switch into at least two portions, of which one has means (51) for engagement with the rocker element and the other, corresponding to the projecting portion of the button, has a bracket (56) which can house said pin (61) of the fitting, thus forming the hinge-like coupling.

Patentansprüche

1. Schaltgerät mit einer zusammenbaubaren Struktur für die Wandbefestigung von elektrischen Geräten, mit folgenden Merkmalen: einem Trägerrahmen (2), der dazu gedacht ist, an der Wand befestigt zu werden, und der einen Sitz (5) für die Befestigung der Geräte hat, wobei der Sitz zumindest ein Schaltgerät (4) mit einem Körper (41), der elektrische Kontakte desselben häußt, aufweist, einem Knopf (50), der dem Körper auf der gegenüberliegenden Seite bezüglich der Seite, die der Wand entspricht, zugeordnet ist, und mittels einer Drehbewegung auf die Kontakte wirkt, dadurch gekennzeichnet, daß der Sitz (5) nur teilweise von dem Schaltgerät (4) besetzt ist, und daß ein Abschnitt des Knopfes (50)

- von dem Körper des Geräts in den Abschnitt des Sitzes (5) seitlich vorsteht, der nicht durch das Schaltgerät besetzt ist, wobei ein Paßstück (60) in dem Abschnitt entferntbar eingeführt ist, das eine scharnierartige Kopplung mit dem vorstehenden Abschnitt des Knopfs (50) um eine Achse, die im wesentlichen parallel zu der Achse der Drehbewegung desselben ist, bildet.
2. Schaltgerät mit einer zusammenbaubaren Struktur gemäß Anspruch 1, dadurch gekennzeichnet, daß das Paßstück einen Körper hat, der mit einer elastischen Ineingriffnahmeinrichtung für eine lösbare Befestigung desselben in dem Sitz versehen ist.
 3. Schaltgerät mit einer zusammenbaubaren Struktur gemäß Anspruch 2, dadurch gekennzeichnet, daß die elastische Ineingriffnahmeinrichtung des Paßstücks die gleiche ist wie die der Geräte, die für die Struktur entworfen sind.
 4. Schaltgerät mit einer zusammenbaubaren Struktur gemäß einem der Ansprüche 1 bis 3, dadurch gekennzeichnet, daß der Knopf (50) an einem Wippelement (42) entferntbar befestigt ist, das in dem Körper des Schaltgeräts umfangsmäßig angebracht ist und eine Schwenkbewegung durchführen kann.
 5. Schaltgerät mit einer zusammenbaubaren Struktur gemäß einem der Ansprüche 1 bis 4, dadurch gekennzeichnet, daß das Paßstück eine Breite hat, die gleich der Breite der Geräte ist, die für die Struktur entworfen sind.
 6. Schaltgerät mit einer zusammenbaubaren Struktur gemäß einem der Ansprüche 1 bis 5, dadurch gekennzeichnet, daß der Abschnitt des Körpers des Paßstücks (60), der neben dem Knopf des Schalters angeordnet ist, wenn sich die Struktur in dem eingebauten Zustand befindet, einen Vorstand hat, in dem ein Loch 62 ist, das einen Transversalstift (61) trägt.
 7. Schaltgerät mit einer zusammenbaubaren Struktur nach einem der Ansprüche 2 bis 6, dadurch gekennzeichnet, daß der Knopf einen vorstehenden Rand (54) um sein Profil sowie eine Aufteilung (55) hat, die die Seite des Hebels teilt, die dazu gedacht ist, dem Schalter in zumindest zwei Abschnitten gegenüberzuliegen, von denen einer eine Einrichtung (51) zur Ineingriffnahme mit dem Wippelement hat, und der andere entsprechend dem vorstehenden Abschnitt des Knopfes einen Träger (56) hat, der den Stift des Paßstücks häusen kann, wodurch die scharnierartige Kopplung gebildet wird.
 8. Schaltgerät mit einer zusammenbaubaren Struktur gemäß einem der Ansprüche 1 bis 7, dadurch gekennzeichnet, daß das Paßstück und der Knopf des Schalters aus Kunststoffmaterial gebildet sind.
 9. Schaltgerät mit einer zusammenbaubaren Struktur gemäß einem der Ansprüche 1 bis 8, bei dem
 - das Paßstück (60) einen Körper hat, der mit einer elastischen Ineingriffnahmeinrichtung für ein lösbares Befestigen desselben in dem Sitz (5) versehen ist, wobei der Abschnitt des Körpers, der neben dem Knopf des Schalters angeordnet ist, wenn sich die Struktur in der zusammengebauten Position befindet, einen Vorstand hat, in dem ein Loch (62) ist, das einen Transversalstift (61) trägt, und
 - der Knopf (50) einen vorstehenden Rand (54) um sein Profil sowie eine Aufteilung (55) hat, die die Seite des Hebels, die dem Schalter gegenüberliegen soll, in zumindest zwei Abschnitte teilt, wobei ein Abschnitt derselben eine Einrichtung (51) zur Ineingriffnahme mit dem Wippelement hat, und wobei der andere Abschnitt entsprechend dem vorstehenden Abschnitt des Knopfes einen Träger (56) hat, der den Stift (61) des Paßstücks häusen kann, wodurch die scharnierartige Kopplung gebildet wird.

Revendications

1. Dispositif de commutation avec une structure en sections pour le montage mural de dispositifs électriques, comportant un bâti (2) de support qui est prévu pour être fixé sur le mur et comporte un siège (5) destiné au montage des dispositifs, le siège contenant au moins un dispositif de commutation (4) ayant un corps (41) logeant ses contacts électriques, un bouton (50) associé au corps sur le côté opposé à celui correspondant au mur, et agissant sur les contacts au moyen d'un mouvement de pivotement, caractérisé en ce que ledit siège (5) n'est occupé que partiellement par le dispositif de commutation (4) et en ce qu'une partie du bouton (50) fait saillie latéralement du corps du dispositif jusque dans la partie du siège (5) qui n'est pas occupée par le dispositif de commutation, partie dans laquelle est insérée de façon amovible une garniture (60) qui forme un accouplement analogue à une charnière avec la partie en saillie du bouton (50) autour d'un axe sensiblement parallèle à celui de son mouvement de pivotement.
2. Dispositif de commutation avec une structure en sections selon la revendication 1, caractérisé en ce que la garniture comporte un corps pourvu de

moyens d'enclenchement élastiques pour son montage amovible dans le siège.

3. Dispositif de commutation avec une structure en sections selon la revendication 2, caractérisé en ce que les moyens d'enclenchement élastiques de la garniture sont identiques à ceux des dispositifs conçus pour la structure. 5
4. Dispositif de commutation avec une structure en sections selon l'une quelconque des revendications 1 à 3, caractérisé en ce que le bouton (50) est fixé de façon amovible à un élément basculant (42) qui est monté de façon périphérique dans le corps du dispositif de commutation et peut effectuer un mouvement de pivotement. 10
15
5. Dispositif de commutation avec une structure en sections selon l'une quelconque des revendications 1 à 4, caractérisé en ce que la garniture a une largeur égale à celle des dispositifs conçus pour la structure. 20
6. Dispositif de commutation avec une structure en sections selon l'une quelconque des revendications 1 à 5, caractérisé en ce que la partie du corps de la garniture (60) qui est disposée de façon à être adjacente au bouton du commutateur lorsque la structure est dans l'état assemblé comporte une saillie dans laquelle se trouve un trou (62) portant une broche transversale (61). 25
30
7. Dispositif de commutation avec une structure en sections selon l'une quelconque des revendications 2 à 6, caractérisé en ce que le bouton comporte un rebord en saillie (54) autour de son profil, ainsi qu'une cloison (55) divisant la face du levier qui est destinée à être tournée vers le commutateur en au moins deux parties dont l'une comporte un moyen (51) destiné à s'enclencher avec l'élément basculant et l'autre, correspondant à la partie en saillie du bouton, comporte une patte (56) qui peut loger la broche de la garniture, formant l'accouplement analogue à une charnière. 35
40
45
8. Dispositif de commutation avec une structure en sections selon l'une quelconque des revendications 1 à 7, caractérisé en ce que la garniture et le bouton du commutateur sont formés d'une matière plastique. 50
9. Dispositif de commutation avec une structure en sections selon l'une quelconque des revendications 1 à 8, dans lequel 55
 - la garniture (60) comporte un corps pourvu d'un moyen d'enclenchement élastique pour son montage amovible dans le siège (5), la partie

dudit corps qui est disposée de façon à être adjacente au bouton du commutateur lorsque la structure est dans la position assemblée ayant une saillie dans laquelle se trouve un trou (62) portant une broche transversale (61), et

- le bouton (50) comporte un rebord en saillie (54) autour de son profil, ainsi qu'une cloison (55) divisant la face du levier, qui est destinée à être tournée vers le commutateur, en au moins deux parties dont l'une comporte un moyen (51) destiné à s'enclencher avec l'élément basculant et l'autre, correspondant à la partie en saillie du bouton, comporte une patte (56) qui peut loger ladite broche (61) de la garniture, formant ainsi un accouplement analogue à une charnière.

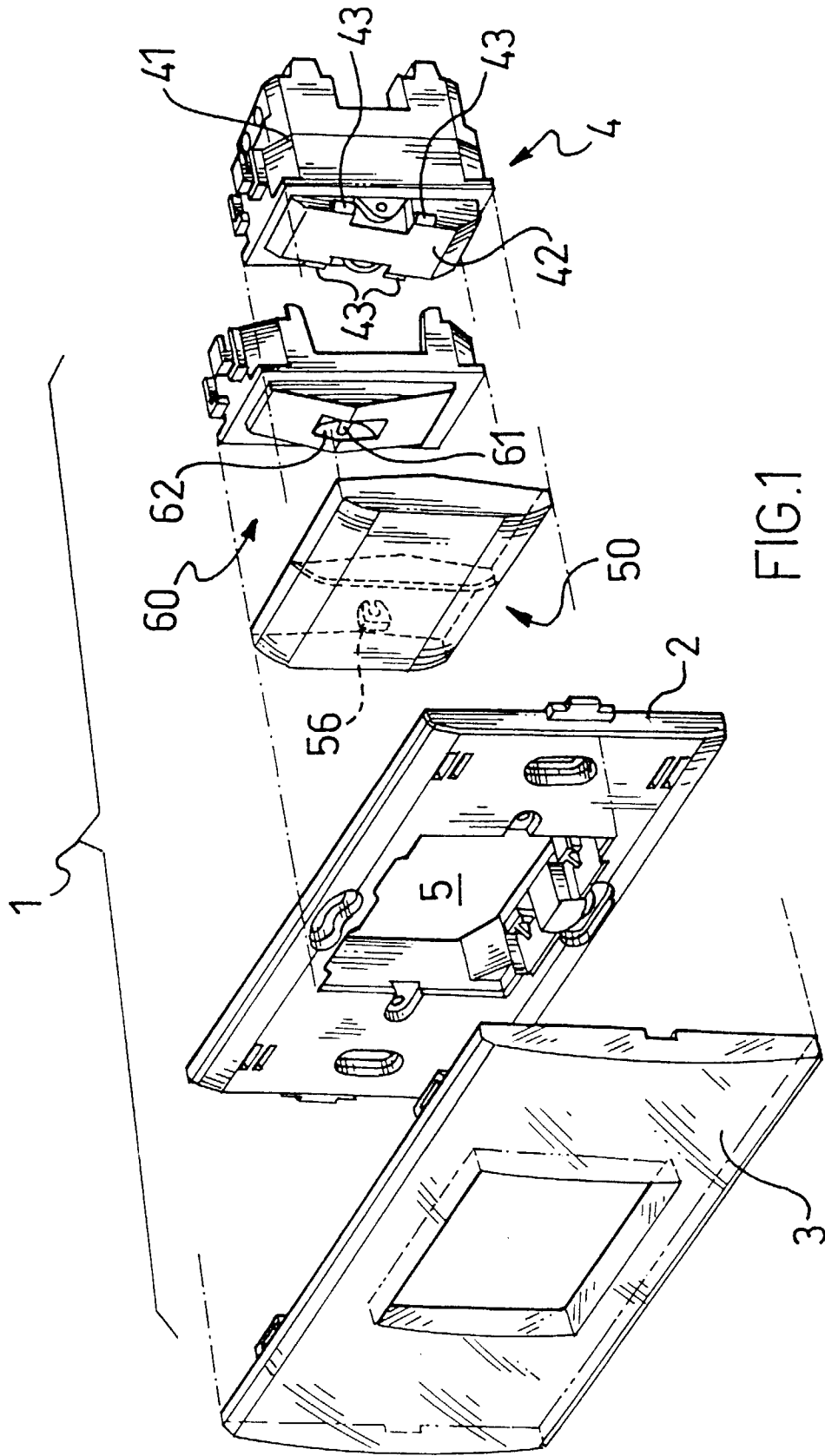

FIG.1

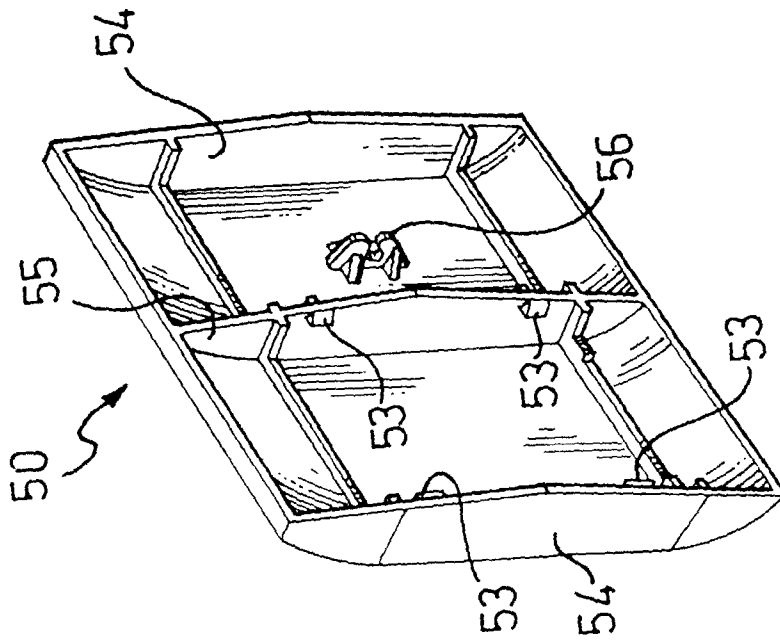

FIG. 2

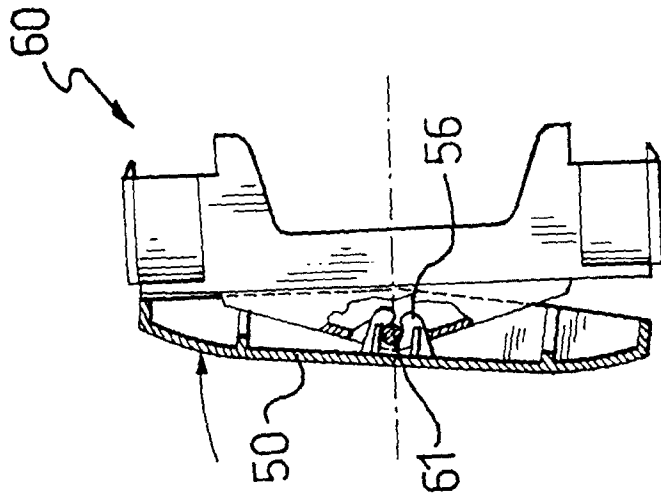

FIG. 3

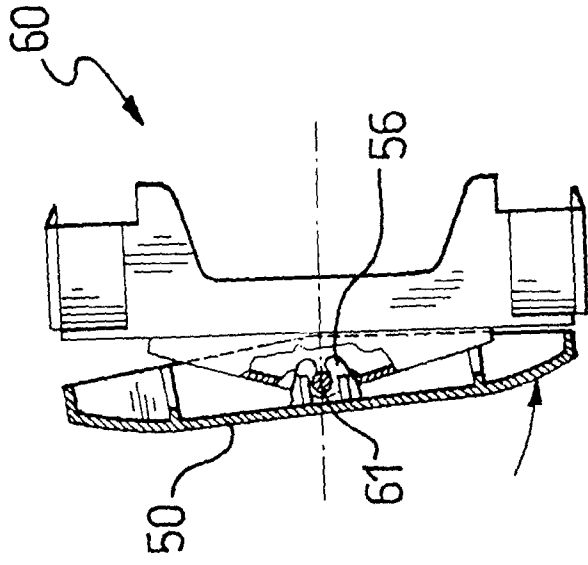

FIG. 4