



Europäisches Patentamt
European Patent Office
Office européen des brevets



(11) **EP 0 764 607 B1**

(12) **EUROPEAN PATENT SPECIFICATION**

(45) Date of publication and mention
of the grant of the patent:
24.05.2000 Bulletin 2000/21

(51) Int Cl.7: **B68C 1/08**

(21) Application number: **96306807.7**

(22) Date of filing: **19.09.1996**

(54) **Improvements in or relating to saddles**

Reitsattel
Selle de cheval

(84) Designated Contracting States:
**AT BE CH DE DK ES FI FR GB GR IE IT LI LU MC
NL PT SE**

(30) Priority: **21.09.1995 GB 9519291**

(43) Date of publication of application:
26.03.1997 Bulletin 1997/13

(73) Proprietors:
• **Kempself, David**
Canterbury, Kent CT4 6JS (GB)
• **White, Margaret Lesley**
Canterbury, Kent CT4 6JS (GB)

(72) Inventors:
• **Kempself, David**
Canterbury, Kent CT4 6JS (GB)
• **White, Margaret Lesley**
Canterbury, Kent CT4 6JS (GB)

(74) Representative: **BROOKES & MARTIN**
High Holborn House
52/54 High Holborn
London, WC1V 6SE (GB)

(56) References cited:
CH-A- 446 045

EP 0 764 607 B1

Note: Within nine months from the publication of the mention of the grant of the European patent, any person may give notice to the European Patent Office of opposition to the European patent granted. Notice of opposition shall be filed in a written reasoned statement. It shall not be deemed to have been filed until the opposition fee has been paid. (Art. 99(1) European Patent Convention).

Description

[0001] The present invention relates to improvements in or relating to saddles, particularly for horses. In particular, it relates to a method for improving the fit of a saddle upon the back of a horse, according to claim 1.

[0002] It is an age-old problem to ensure that a saddle conforms well to the shape of a horse's back. Even when a saddle fits a horse well, over the course of a year, changes in the diet of the horse or its fitness will result in changes in muscle structure and the shape of the back, with the result that a saddle which fitted well earlier in the year is no longer so well fitting. At the least, this will cause the horse discomfort and at worst could result in lameness.

[0003] Hitherto, it has been known to provide a padded saddle cloth or numnah. The saddle cloth or numnah is placed between the horse and the saddle and is used to protect the saddle from the perspiration of the horse and to reduce chaffing of the saddle against the horse's skin. The padding is typically sheepskin although foam or gel pads are also utilised. Some gel pads are used in conjunction with a numnah, between the horse and the saddle.

[0004] Another problem to bear in mind is that the saddle cloth, (or numnah or pad) bridges the spine and wither areas of the horse's back. When the horse is ridden the saddle cloth will move under the saddle. It is quite normal that the cloth will be stretched taut across the withers and spine due to the pommel area of the saddle's panel bearing down on either side of the withers. The saddle cloth will then restrict movement of the horse, cutting into it and is therefore another contributing factor to saddle soreness.

[0005] The above methods of protecting the horse's back detract from the rider's preference, particularly in dressage, to be in as close contact as possible with the horse for maximum control over the horse. It is with close contact that the rider transmits commands to the horse through subtle changes in weight distribution through the saddle and pressure applied by the rider's legs. Increasing the separation of the rider from the horse reduces the precision of these subtle changes. In addition, it is important that any method of padding a saddle does not interfere with the gap (traditionally three fingers) left between the tree of the saddle and the withers of the horse. Any such interference will restrict the movement of the horse, especially when the horse needs exaggerated movement of the shoulders i.e. when jumping and in collection or extension in the trot and canter gaits.

[0006] Turning to the saddle, it is the usual practice to push wadding or flocking (usually wool or a synthetic material) into the pockets or panels on either side of the underside of the seat of the saddle, a job requiring the skills of the saddler. These panels, starting at the back of the saddle, run its length along the backbone and then turn downwards following the knee rolls of the saddle

over the horse's shoulders. The wadding is forced through holes in the upper surface of each panel hidden under the stirrup flaps and cantle, thereby forming a cushion for the saddle against the horses back. The saddler needs to be very careful in ensuring consistent density of wadding in the panels to avoid uneven or hard areas which would give rise to discomfort for the horse. However, over the course of time, with riding, the wadding is prone to move and can become hard through compression and the absorption of the horse's sweat. Cleaning of the saddle with water and oils also contribute to the hardening of flocking. A saddle padded in this way will require frequent re-flocking of the panels, requiring the services of a saddler.

[0007] It is with a view to overcoming these disadvantages in the prior art that the present invention has been devised. In particular, it has been an aim of the inventor to provide a saddle which fits the animal's back comfortably, but which also retains the appearance of the traditional saddle.

[0008] The use of air to provide an even bearing surface is not itself new (see for example CH-C-446045, which represents the preamble of claims 1 and 7.) . Applications include an inflatable harness described in US 5,329,751, air filled pads that fit in numnahs are described in GB 2090512 and a saddle pad described in US 5299412. There have even been totally inflatable saddles GB 1453810 and US 4033097 or new saddle designs with inflating parts inside them DE 2259376. Only air filled numnahs have been developed into a marketable product.

[0009] DE 40 36 907 A1 describes in very general terms, the use of a number of air-filled bladders in a saddle. However, whilst setting out the broad idea, this document does not give insight into making the invention possible and indeed some of its generalisations are proven to be impractical when put into practice. For example, the use of elasticated materials for the bladders would prove impossible in practice for the rider to sit on with any degree of comfort or security and in fact could actually prove dangerous.

[0010] In its broadest sense, the present invention provides two foam inserts and two pairs of air filled bladders adapted for insertion into the panels on either side of the underside of a saddle that are adjacent to the backbone of the horse. These bladders and foam inserts replace the existing flocking material. A third optional pair of bladders can be fitted into the panel area just behind the shoulder of the horse, known commonly as the knee roll area, because the knee rolls lie over this part of the panel. All bladders and foam inserts can be fitted into the panels through existing holes originally used to insert the flocking, or by un-stitching the panel, once the original flocking has been removed. Pairs of bladders are divided to the left and right sides of the saddle with a foam insert in each panel. Bladders within a panel will overlap their adjacent bladder/s to form a continuous smooth bearing surface. Air can be adjusted in

each pair of bladders so they may find their own level and equalise the saddle's bearing surface on the horse's back. The saddler utilises a valve to trap air within each bladder once he is satisfied the saddle fits correctly.

[0011] In another aspect, the present invention provides a saddle having a saddle tree and two generally L-shaped pockets or panels constructed within the saddle; wherein a set of inflatable bladders is inserted into each panel: each set comprises a pommel bladder and rear bladder; characterised in that fluid communication means are provided for fluid communication between corresponding bladders in each set; in that each bladder is constructed from a flexible, substantially inelastic material; in that the dimensions of each bladder, in a deflated state, exceeds the dimensions of the area within the panel into which the bladder is inserted, such that adjacent bladders within each panel overlap; and further characterised in that a resilient element is provided between the upper surface of the bladders and the under surface of the seat.

[0012] The present invention in particular provides a means for inflating and deflating opposing pairs of bladders and allowing them to equalise in pressure. The flow of air between the bladders is then impeded or stopped once fitted correctly. This self levelling takes the guess work out of the fitting process, the saddler will always be able to achieve the perfect fit and balance of the saddle.

[0013] The present invention also provides a flat even bearing surface against the horses back by the use of a shaped foam or similar material insert with the bladders. Air bladders alone do not give an even bearing surface due to the mechanics of air filled bladders. We will go on to illustrate that the use of an insert in the invention enables bladders to be used successfully to create a totally even bearing surface.

[0014] The bladders are preferably filled with air or other fluid substance. Preferably air or an other gaseous medium is used primarily due to the advantage of weight and fluidity of movement of this medium.

[0015] Preferably, three pairs of bladders are provided, suitably referred to as a rear bladder pair, a pommel bladder pair and a knee roll bladder pair, by reference to the adjacent areas of the saddle (one of each pair being provided on respective sides of the saddle). It is thought in practice that most riders will adopt the rear and pommel bladders only, opting to leave the knee roll area with traditional flocking. This will not impede the performance of the invention since the main area of concern, adjacent to the backbone and withers are protected by the invention.

[0016] The above and other aspects of the present invention will now be illustrated in further detail with reference, by way of example only, to the accompanying figures in which:

Figure 1 shows in side view a conventional saddle;

Figure 2 illustrates the way in which a saddle of the type shown in Figure 1 is conventionally padded;

Figure 3 is an underside view of the saddle of Figure 1;

Figure 4 is an exploded view of the panel section and its' relation to the saddle tree;

Figure 5 shows an arrangement of bladders and foam insert in an embodiment of the present invention (left side only);

Figure 6 illustrates the variance of panel structures on conventional saddles;

Figure 7 shows an embodiment of a valve construction suitable for use in the present invention;

Figure 8 illustrates a cross section through the saddle showing the achievable bearing surfaces of the panels, created using bladder alone or bladder with foam insert; and

Figure 9 illustrates one of the principles underlying the effectiveness of the present invention.

[0017] To illustrate the present invention, it is convenient to outline the construction of a conventional saddle as is shown in Figures 1 to 4. The saddle 1 comprises a seat 2 rising at the rear of the saddle to form cantle 3, and at the front forming pommel 4 formed over the tree 20 allowing a gap between the saddle and the withers of the horse, to ensure that the saddle does not inhibit movement. As will be discussed in further detail, the underside of the saddle is formed with a generally 'L' shaped panel 5 on either side of a gullet 6, which sits over the horse's spine; and panel flaps 7 which serve to protect the horse's skin from rubbing against the girth strap 8 by which the saddle is secured to the horse's back. A seat flap 9 protects the rider from the girth strap and the stirrup 10 is attached to a hook (not shown) between the seat flap 9 and a stirrup flap or skirt 11 of the seat 2.

[0018] The conventional saddle is actually made in two pieces (see Figure 4) and comprises:-

i) A seat section which embodies seat 2, cantle 3, pommel 4, tree 20, tree points 21, seat flaps 9 and stirrup flaps 11.

ii) A panel section which consists of panels 5 with flocking holes 12 with pommel gusset 14 and rear gusset 15 which connect the panels together and tree pockets 16. The tree pockets 16 enclose the tree points 21 when the two sections are brought together aiding their adhesion to one another.

[0019] The two sections are stitched together at the front and back of the saddle with the tree points 21 inserted in the tree pockets 16. The stitching at the back of the saddle connects the exposed rear section of the panel 5 and rear gusset 15 to the cantle 3. At the front, the pommel of the seat section is stitched to the matching area of the panel section including the pommel gusset 14. Starting adjacent the tree pocket on one side, stitching runs the pommel to the corresponding position on the other side of the saddle.

[0020] In the prior art arrangement described above, wadding or flocking is inserted into the panels 5 on either side of the saddle 1 through one or more flocking holes 12.

[0021] It will become apparent that a major advantage of the present invention is that it makes use of an entirely conventional saddle, that is, it is not necessary to have a saddle specially made or to replace an existing saddle, with the expense that that would entail. It also does not destroy the fabric of the saddle in anyway.

[0022] Figure 5 illustrates schematically the embodiment of the present invention in which three bladders and a foam insert are provided in each pocket of the panels 5; a rear bladder 30, a pommel bladder 31, a foam insert (38) and a knee roll bladder 32. The bladders may be inflated by means of respective hoses 33 which are attached to the bladders via a welded flange 34. It should be noted that the bladders always overlap therefore giving a smooth transition between the different zones of inflation i.e. pommel, rear and knee roll. This smooth transition is vital in order that the saddle does not yaw front to back on the horse.

[0023] Materials suitable for manufacture of the bladders would have to have a good abrasion resistance whilst being supple enough to form perfectly within the panel but not have elastic characteristics (as this induces a bouncing effect which is undesirable). To this end PVC laminated sheet or Polyurethane sheet is the best material for the bladders. A typically good material would be a PVC marketed under the name Rectaleen U49 (registered trade mark).

[0024] Rectaleen U49 is made of 2 x 175 mym plys bonded together with polyurethane adhesive. It is made to BS2782 Part 1 and can withstand temperatures of -25°C before cold cracking.

[0025] Another worthy material is Polyurethane Film. Unlike PVC it is not porous and does not require lamination. Its abrasion resistance is much better than PVC along with low temperature flexibility. This material is very new on the market in a high frequency radio welding form and so may prove too expensive or be over specified for the application.

[0026] Two flat sheets of the above materials can easily be formed into bladders using radio welding techniques that are very cost effective in production and tooling. Special attention to the welding process has to be noted. The seam or weld 36 must be achieved in such a way that the minimum of excess material is left along

the seam. If this were not so there could be the possibility of a ridge of material being felt through the saddle by the horse. The weld whilst being strong does not have to withstand huge pressures as typically the pressures created on the horses back and therefore within the saddle are about 1.5 pounds per square inch.

[0027] In practice, each bladder will be 30-40% oversized for the panel 5 it is to be fitted in to, so that when inflated, the bladder takes up all the available space within the panel and overlaps adjacent bladders without leaving a gap. This is shown by dotted line 37 which shows the actual size of the panel 5. This must be the case so that the rider does not feel the bladders have a bouncy effect, which would be most unsuitable and undesirable. The overlap area of bladders within the saddle should be approximately 25% of the front to back measurement of the panel to give a smooth transition between inflated zones of the saddle.

[0028] In practice there will probably be three or four sizes of each bladder to cover the various sizes of saddle from pony to large horse.

[0029] There will be a need to manufacture different shaped bladders for the pommel area of the saddle. The other rear and knee roll areas of the saddle do not vary sufficiently to need different shapes of bladder.

[0030] The pommel area of a panel, varies in shape depending on the design or make of saddle. In essence there are four panel designs which are illustrated in Figure 6.

1. Standard Panels 5
2. Drop panels 62
3. Half panels 63
4. Full panels 64

[0031] The different panels produce a change in the flocking area mainly around the wither or pommel area. The smallest bearing surface produced is the standard panel 5 followed by the drop panel 62, then the half panel 63 and finally the full panel 64. It should be noted that areas 62, 63 and 64 are enlargements on the previous panel dimension, therefore $5+62+63+64 =$ a full panel. Each takes more available area of the panel flap 7. This variance is due to the needs of higher, narrower withered horses such as thoroughbred's needing a larger bearing surface around the withers to stop saddle soreness..

[0032] It is not essential in some of these panels that all the available area be replaced with bladders, since the area of concern is localised along either side of the spine processes as in the standard panel. There will have to be different shapes of bladder to accommodate the different varieties of panel and the saddler will be advised as to how to approach fitting bladders in saddles with panels differing from the standard. Flocking mate-

rial will stay in place for the majority of the area directly under the riders leg in the case of the full panel version. Having said all this, by far the most popular and common saddle has a standard panel design for which no special attention is needed.

[0033] Therefore in definition the bladders must take up all available room within the panel without any portion of the bladder being inflated so its material is stretched thus preventing an elasticised bouncy consistency within the panel and they must overlap so as to provide a consistent smooth bearing surface.

[0034] The horse's back changes in shape (cross section) as one looks at the back in sections moving from the withers (over which the pommel 4 sits), through a section upon which the front of the seat 2 of the saddle sits, to a section upon which the rear of the seat 2 of the saddle sits.

[0035] The withers are nearer to the vertical at their uppermost point and form a hollow at their base. Therefore the pommel bladders 31 must form themselves to either side of this irregular bearing surface to enable the pommel 4 and tree 20 of the saddle to be borne 40 - 50mm above the horse's wither.

[0036] The nature of the muscle structure in this region mean that the cross sectional shape of the withers will constantly change as the horse moves. Accordingly the pommel bladder must be totally fluid to ensure that the movement of this muscle mass is not impeded as it is in a conventionally flocked saddle.

[0037] The horse's back at the rear of the seat 2 of the saddle is comparatively flat. Accordingly the bearing surface produced by the panel 5 and bladders 30 should be capable of forming to this profile.

[0038] The panel 5 should present the largest possible bearing surface against the horse's back. Figure 8 illustrates both the problem that is caused by utilising the bladder 30 alone in the panel 5 and the solution of using a foam insert 38 with a bladder 30. The problem with the left hand side 40 is that the pressure within the bladder 30 creates a round profile in cross section. This causes the panel 5 to have a sausage like appearance when inflated and a bearing surface 42 against the horse's back.

[0039] In contrast Figure 8 also shows that the right hand panel 41 has a larger bearing surface 43 against the horse's back. This is achieved by the insertion of a specially shaped foam insert 38 in such a way that the bladder 30 wraps around the lower and side surfaces of the foam insert 38. When the rear bladder 30 is inflated, the foam insert 38 forces the air in the bladder 30 to create a flatter and larger bearing surface 43.

[0040] It is easy to see from Figure 8 that the bearing surface 43 created by the addition of the foam insert 38 is much greater than the bearing surface 42 when a bladder alone is used. The riders weight is therefore distributed over a much greater area on the horse's back so reducing the pressure exerted per square inch. Without this foam insert 38 a saddle using bladders alone in

the panel will create a concentrated pressure ridge which will be greater than pressures exerted by a correctly conventional flocked saddle. Therefore no benefit is achieved by filling the saddle panel 5 solely with air.

[0041] The foam may be an open or closed cell foam or a composite comprising both types of foam.

[0042] By this disclosure we illustrate the inventive advantage over earlier disclosures in the aforementioned patent applications. Any use of air in a bladder will form ridge type pressure points if the bladder is not formed and contained within a structure which enable it to form a flat even bearing surface. In Figure 9 this point is illustrated. A single bladder 70 is shown supporting a load and exerting a pressure point 73 on the bearing surface 74. Three bladders bearing the same load are shown at 71 and create three separate pressure points 73. The principle applied by the present invention wherein a semi rigid foam 38 is employed to shape the bladder is shown at 72 illustrating that there are no point loads on the bearing surface 74.

[0043] As shown, the preferred arrangement of the present invention is to have three bladders in each panel 5. Inflation of opposing pairs of bladders is essential to accurate adjustment of the saddle with respect to the horse's back i.e. the pressure on both sides of the back bone is the same. For this reason, each pair of bladders are linked and served by a single valve 50 i.e. rear bladders link to one valve, pommel bladders to another etc.

[0044] The valves may be positioned in any convenient position on the saddle. Typically, they will be positioned at the rear of the cantle 3 as this is the most accessible place for the saddle fitter.

[0045] Figure 7 illustrates an embodiment of a valve body 51 which acts as a manifold for the air. Equal amounts of air are passed to each bladder in a pair i.e. rear, pommel and knee roll, via hoses 52. These valve bodies have a means of stopping the air from moving between bladders at the point when the saddler is satisfied that the saddle fits correctly and is balanced (left to right) on the horse's back.

The valve 50 as shown consists of a valve body 51 incorporating a Schrader type valve 53 commonly used on cars and motorbikes. These valves are easily available, reliable and due to their world wide adoption by car manufacturer are very cheap.

[0046] The Schrader valve is encapsulated in a nylon or brass valve body 51 which has two pipe entries 52 and two grub screws 54. When the grub screws are retracted they ensure an equalisation of pressures in the matching pairs of bladders therefore giving a completely level saddle as it is inflated and/or deflated whilst the rider is sitting on the saddle. The grub screws have several benefits including:

- i) They stop the flow of air between the bladders once the saddler has inflated the bladders and allows them to equalise and level. It is very undesirable to have the air flowing between bladders when

the rider shifts his weight. This would over a period of time induce the saddle to roll to one side. If the rider always rode lopsided the saddle would exaggerate this if the air was not stopped from moving;

ii) They allow the saddler to shut off the feeds to the bladders stopping the user from tampering with the saddle fitting. Anti-tamper paint may be used on the screws so the saddler would know if any tampering had occurred. The saddler by capping the pipes in such a way that tampering would be obvious ensure he has a means of commercial protection; and

iii) They act as a second seal for the valve.

[0047] Although, the present system has valves bodies 51 incorporating grub screws 54 to seal off the air flow between bladders, it is envisaged that it is possible to do way with the grub screws 54 altogether and use a different method of sealing. The same effect could be achieved by injecting through the Schrader valve 53 a substance with the consistency of petroleum jelly. In fact petroleum jelly is an ideal substance. This substance can be injected quite simply using a bicycle pump in the same manner as when inflating the bladders with air. The substance is injected into the valve body and down the 3mm hoses 52 so that they are filled to a length of approximately 25mm from the valve body. This would be sufficient to create a satisfactory seal. The substance will not move from this position since its viscosity is such that the force required to move the substance is far in excess of the normal working pressures.

[0048] When the saddler wishes to readjust the saddle he must first unscrew the Schrader valve 53 and flush out the substance with boiling water then replace the valve. He can then inject more of the substance to seal the hoses once he has carried out the adjustment to the bladders. Another, probably more convenient method of removing the substance would be with a bicycle pump that is modified to suck like a syringe rather than blow, so the substance can be sucked out through the Schrader valve 53 without removing it.

[0049] The valve body 51 can be made of nylon, brass or aluminium and has been designed to be economic in manufacture by being able to be turned simply.

[0050] The hoses 52 from the valve 50 to the bladders can be made of nylon or other appropriate material. They must have a sufficiently small enough internal diameter (typically 1.5mm) and long enough length (600mm) to impede the movement of air between bladders i.e. if the hose were shorter the air would pass more quickly through it since it is not only the diameter of the hose that causes air restriction but also the length of the hose by the resistance imparted by the wall of the hose on the air flow.

[0051] These hoses 52 will have an external diameter sufficiently small that they can be hidden within the fabric of the seat section of the saddle (not the panel 5)

under the seat 2. Approximately 3.5mm is considered suitable. If the hoses were routed through the panel 5 they may be detected by the horse as pressure points.

[0052] In a typical arrangement, these hoses 52 will connect into the short length (75mm) of larger diameter PVC hose 33 on the bladders. The hoses 33 on the bladders will have a 6mm OD 3mm ID and will be welded or glued into a flange 34 on the bladder. The positioning of these flanges is important so as to be undetectable by the horse through the panel fabric. If they were not they could cause greater pressure point problems than the flock they replace.

[0053] The joining of the 3.5mm hose 52 to the 6mm hose 33 can simply be a push fit. The 6mm PVC hose will stretch to accept the 3.5mm Nylon hose and should be pushed in at least 20-25 mm. This will be sufficient to create an air tight seal whilst also giving a method of disconnection of the valves from the bladders. Alternatively, this joint can be permanently glued with an adhesive such as cyanoacrylate (super-glue).

[0054] The bladders can be readily incorporated into a new saddle during manufacture or easily inserted into an existing saddle through the same holes 12 used for inserting wadding or flocking. Small crosscut holes 17 must be made in the panel's upper surface for the 6mm hoses to pass through. The positioning of these holes should be as near to a solid structure of the saddle as possible i.e. The points of the saddle tree 21 for the pommel bladder hoses and the gusset that bridges the backbone 15 at the rear of the panel. They should also be on the upper side of the panel so they are not visible when the panel section and seat section are stitched together.

[0055] Fitting of the new bladders will therefore be a simple task of...

1. Remove the panel section 5 of the saddle by undoing the stitching at the pommel and rear sections that fix the panel section to the seat section;
2. Remove the required amount of flocking through the existing flocking holes 12;
3. Cut small holes or crosscuts 17 in the upper surface of panel 5 (rider's side) that correspond with the position of the 6mm hoses 33 that serve the bladders 30, 31 & 32 when they are fitted in position;
4. Fit the bladders 30, 31 and 32 by rolling them up length ways and inserting them through the existing flocking holes 12 passing the 6mm hoses 33 through the crosscut holes 17 that were cut in step 3;
5. Fit the foam inserts 38 into position through the flocking holes 12 making sure that the bladder surround 30 & 31 the sides of the foam insert;
6. Pass the 3.5mm hoses 52 of the valves 50 through the seat section of the saddle so that they emerge from the fabric of the saddle in corresponding positions of the 6mm hoses 33 so they may be joined to the 6mm hoses 33 when the seat and pan-

el sections are stitched back together again; and
7. Finally, join the hoses 33 & 52 together and stitch the saddle back together.

[0056] An eyelet 35 may be provided on the end of the knee-roll bladder, or indeed any other bladder, to assist insertion into the saddle panel.

[0057] Typically, once the bladders have been inserted into the panels of the saddle, they will be inflated. This is carried out once the grub screws 54 in the valve bodies 51 have been retracted to allow equal air flow to both bladders in a pair. The above, will be done prior to fitting the saddle onto the horse and the rider mounting the horse.

[0058] When the rider has mounted the horse, air will either be pumped into the bladders (using a standard bicycle pump) or let out of the bladders (by releasing the schrader valve 53) until the saddle conforms to the shape of the horse's back and is square in all planes. All of the adjustments are done by eye. This is a unique way of fitting a saddle since the traditional method meant the rider get on and off the horse to allow more flocking to be added to the panels.

[0059] There is no need to measure the pressure in the bladders. The pressures will be very small and would not differ to any great extent between different riders. The overall bearing surface of a man's saddle is approximately 140 square inches or 960 square centimetres. If the man weighed 16 stone, (224 pounds), 101kg he would create an internal pressure in the bladders of no more than 1.5 pounds per square inch, 100g per square centimetre.

[0060] The present invention is suitable for inclusion in any style of saddle, be it for racing, eventing, dressage, show jumping, endurance, hunting and general recreation and so on. It will also be possible to incorporate the valves into the cantle 12 if the saddle were to be manufactured with the bladders from new.

[0061] The invention herein described has been tested by the inventors using state-of-the-art equipment that measures the pressures applied by the saddle on the horses's back. This equipment consists of a thin saddle cloth with 256 no. pressure sensors (each being 25mm square) over its surface. The cloth is attached to a computer via a cable and with specialised software the computer produces images of the pressures present under a saddle. The image is very much like that given by a thermal image camera.

[0062] It has been with the use of this equipment that the inventors have proven that it is not possible to achieve a flat consistent bearing surface using air filled bladders alone. The shaped foam inserts are the only way of achieving a fluid yet flat bearing surface against the horse's back.

[0063] The inventors have not only addressed and overcome the physical and anatomical problems related to this concept but also disclosed a product in a form that is both acceptable, achievable and cost effective to

the market place.

Claims

1. A method of improving the conformity with a horse's back of a conventional saddle (1) having a saddle tree (20) and two generally L-shaped pockets or panels (5) constructed within the saddle(s); wherein the method comprises inserting a set of bladders into each L-shaped panel and inflating the bladders with air or other fluid medium to form a cushion between the two faces of each bladder such that the two faces of the bladder are held apart; each set comprises a pommel bladder (31) and a rear bladder (30), characterised in that corresponding bladders in each set are in sealable fluid communication; the bladders are constructed from a flexible, substantially inelastic material; the dimensions of each bladder, when deflated, exceed the dimensions of the area in the saddle into which they are to be inserted, such that adjacent bladders within each panel overlap; and further characterised in that a resilient element (38) is inserted between the pommel and rear bladders (30 & 31) and the under surface of the seat (2).
2. A method as claimed in Claim 1, wherein i) the dimensions of the each bladder, when deflated, exceed the dimensions of the respective area of the saddle by 30-40%; and/or in each set overlap, within the saddle, by about 25% front to back.
3. A method as claimed in Claim 1 or Claim 2 wherein each set further comprises a knee roll bladder (32).
4. A method as claimed in any one of Claims 1 to 3 wherein corresponding bladders in each set are inflated through a common valve, preferably a schrader-type valve (50).
5. A method as claimed in Claim 4 wherein the valve includes two grub screws which, in use, are adjustable to seal fluid communication between respective bladders in each set.
6. A method as claimed in any preceding claim wherein the resilient element (38) is made of a foamed material.
7. A saddle (1) having a saddle tree (20) and two generally L-shaped pockets or panels (5) constructed within the saddle (1); wherein a set of inflatable bladders is inserted into each panel (5): each set comprises a pommel bladder (31) and rear bladder (30); characterised in that fluid communication means (50) are provided for fluid communication between corresponding bladders in each set; in that

each bladder is constructed from a flexible, substantially inelastic material; in that the dimensions of each bladder, in a deflated state, exceeds the dimensions of the area within the panel (5) into which the bladder is inserted, such that adjacent bladders within each panel overlap; and further characterised in that a resilient element (38) is provided between the upper surface of the bladders (30 & 31) and the under surface of the seat (2).

8. A saddle as claimed in Claim 7 wherein

- i) the dimensions of each bladder exceed the dimensions of the respective area of the saddle by 30-40%; and/or
- ii) adjacent bladders overlap by about 25%.

9. A saddle as claimed in Claim 7 or Claim 8 wherein each set further comprises a knee roll bladder.

10. A saddle as claimed in any one of Claims 7 to 9 wherein the resilient insert (38) is made of a foamed material.

Patentansprüche

1. Verfahren zum Verbessern der Passform eines herkömmlichen Sattels (1) an einen Pferderücken mit einem Sattelbaum (20) und mit zwei im wesentlichen L-förmigen Taschen oder Paneelen (5) innerhalb des Sattels, wobei das Verfahren das Einführen eines Satzes von Bälgen in jedes L-förmige Paneel sowie das Aufblasen der Bälge mit Luft oder einem anderen fließfähigen Medium umfasst zum Bilden eines Kissens zwischen den beiden Flächen eines jeden Balges, derart, dass die beiden Flächen des Balges auseinandergehalten werden, wobei jeder Satz einen Knaufbalg (31) und einen rückwärtigen Balg (30) umfasst, dadurch gekennzeichnet, dass einander entsprechende Bälge in jedem Satz in abdichtbarer leitender Verbindung miteinander stehen; die Bälge aus einem flexiblen, im wesentlichen nicht-elastischen Material aufgebaut sind, dass die Abmessungen eines jeden Balges in nicht aufgeblasenem Zustand, die Abmessungen jenes Bereiches des Sattels überschreiten, in welchem sie eingeführt werden, so dass sich einander benachbarte Bälge innerhalb eines jeden Paneels überlappen, weiterhin dadurch gekennzeichnet, dass ein elastisches Element (38) zwischen dem Knaufbalg und dem rückwärtigen Balg (30, 31) sowie unter die Fläche des Sitzes (2) eingeführt wird.
2. Verfahren nach Anspruch 1, wobei (1) die Abmessungen eines jeden Balges in entleertem Zustand die Abmessungen des entsprechenden Bereiches des Sattels um 30 bis 40 % übersteigt und/oder in

jedem Satz innerhalb des Sattels um 25 % von vorn nach hinten überlappt.

3. Verfahren nach Anspruch 1 oder 2, wobei jeder Satz weiterhin einen Kniepauche-Balg (23) umfasst.

4. Verfahren nach einem der Ansprüche 1 bis 3, wobei einander entsprechende Bälge in jedem Satz durch ein gemeinsames Ventil, vorzugsweise ein Schieber-Ventil (50) aufgeblasen werden.

5. Verfahren nach Anspruch 4, wobei das Ventil zwei Stellschrauben umfasst, die beim Gebrauch derart justierbar sind, dass sie zwischen einander entsprechenden Bälgen in jedem Satz eine leitende Verbindung absperren können.

6. Verfahren nach einem der vorausgegangenen Ansprüche, wobei das elastische Element (38) aus einem geschäumten Material besteht.

7. Sattel (1) mit einem Sattelbaum (20) und zwei im wesentlichen L-förmigen Taschen oder Paneelen (5) innerhalb des Sattels (1), wobei ein Satz aufblasbarer Bälge in jedes Paneel (5) eingesetzt ist, und jeder Satz einen Knaufbalg (31) und einen rückwärtigen Balg (30) umfasst, dadurch gekennzeichnet, dass eine Einrichtung (50) zum Herstellen einer leitenden Verbindung zwischen entsprechenden Bälgen in jedem Satz vorgesehen ist, dass jeder Balg aus einem flexiblen, im wesentlichen nicht-elastischen Material aufgebaut ist, dass die Abmessungen eines jeden Balges in entleertem Zustand die Abmessungen jenes Bereiches innerhalb des Paneels (5) übersteigt, in welchem der Balg eingesetzt ist, derart, dass sich einander benachbarte Bälge innerhalb eines jeden Paneels überlappen, und weiterhin dadurch gekennzeichnet, dass ein elastisches Element (38) zwischen der oberen Fläche der Bälge (30, 31) und der unteren Fläche des Sitzes vorgesehen ist.

8. Sattel nach Anspruch 7, wobei (1) die Abmessungen eines jeden Balges die Abmessungen des entsprechenden Bereiches des Sattels um 30 bis 40 % übersteigen; und/oder (II) einander benachbarte Bälge sich um etwa 25 % überlappen.

9. Sattel nach Anspruch 7 oder 8, wobei jeder Satz weiterhin einen Kniepauche-Balg umfasst.

10. Sattel nach einem der Ansprüche 7 bis 9, wobei der elastische Einsatz (38) aus geschäumtem Material hergestellt ist.

Revendications

1. Procédé pour amener une selle classique (1) à mieux épouser le dos d'un cheval, la selle comportant une arcade (20) et deux poches ou panneaux globalement en forme de L (5) construits à l'intérieur de la selle (des selles) ; le procédé comprenant les étapes consistant à insérer un jeu de vessies dans chaque panneau en L et à gonfler les vessies avec de l'air ou un autre fluide pour former un coussin entre les deux faces de chaque vessie de manière que les deux faces de la vessie soient maintenues écartées ; chaque jeu comprenant une vessie de pommeau (31) et une vessie arrière (30), caractérisé en ce que des vessies correspondantes dans chaque jeu sont en communication de fluide pouvant être interrompue ; les vessies sont constituées d'un matériau flexible, sensiblement inélastique ; les dimensions de chacune des vessies, une fois celles-ci dégonflées, sont supérieures aux dimensions de la région de la selle dans laquelle elles doivent être insérées, de manière que des vessies adjacentes au sein de chaque panneau se chevauchent ; et caractérisé également en ce qu'un élément élastique (38) est inséré entre les vessies de pommeau (31) et arrière (30) et la surface de dessous du siège (2).

5
10
15
20
25
2. Procédé selon la revendication 1, dans lequel i) les dimensions de chaque vessie, une fois celle-ci dégonflée, sont supérieures aux dimensions de la région respective de la selle de 30 à 40 % ; et/ou dans chaque jeu les vessies se chevauchent, au sein de la selle, d'environ 25 % d'avant en arrière.

30
35
3. Procédé selon la revendication 1 ou la revendication 2, dans lequel chaque jeu comprend également une vessie de bourrelets de genoux (32).

40
4. Procédé selon l'une quelconque des revendications 1 à 3, dans lequel des vessies correspondantes dans chaque jeu sont gonflées via une valve commune, de préférence une valve de type Schrader (50).

45
50
5. Procédé selon la revendication 4, dans lequel la valve comprend deux vis sans tête qui, à l'utilisation, sont réglables pour interrompre une communication de fluide entre des vessies respectives dans chaque jeu.

55
6. Procédé selon l'une quelconque des revendications précédentes, dans lequel l'élément élastique (38) est constitué d'un matériau moussé.

55
7. Selle (1) comportant une arcade (20) et deux poches ou panneaux globalement en forme de L (5) construits à l'intérieur de la selle (1) ; dans laquelle un jeu de vessies gonflables est inséré dans chaque panneau (5) ; chaque jeu comprend une vessie de pommeau (31) et une vessie arrière (30) ; caractérisée en ce qu'un moyen de communication de fluide (50) est prévu pour une communication de fluide entre des vessies correspondantes dans chaque jeu ; en ce que chaque vessie est constituée d'un matériau flexible, sensiblement inélastique ; en ce que les dimensions de chaque vessie, une fois celle-ci dégonflée, sont supérieures aux dimensions de la région au sein du panneau (5) dans laquelle la vessie est insérée, de manière que des vessies adjacentes au sein de chaque panneau se chevauchent ; et caractérisée également en ce qu'un élément élastique (38) est inséré entre la surface supérieure des vessies (30 & 31) et la surface de dessous du siège (2).

5
10
15
20
25
30
35
40
45
50
55
8. Selle selon la revendication 7, dans laquelle :
 - i) les dimensions de chaque vessie sont supérieures aux dimensions de la région respective de la selle de 30 à 40 % ; et/ou
 - ii) des vessies adjacentes se chevauchent d'environ 25%.
9. Selle selon la revendication 7 ou la revendication 8, dans laquelle chaque jeu comprend également une vessie de bourrelets de genoux.
10. Selle selon l'une quelconque des revendications 7 à 9, dans laquelle l'insert élastique (38) est constitué d'un matériau moussé.

Figure 1

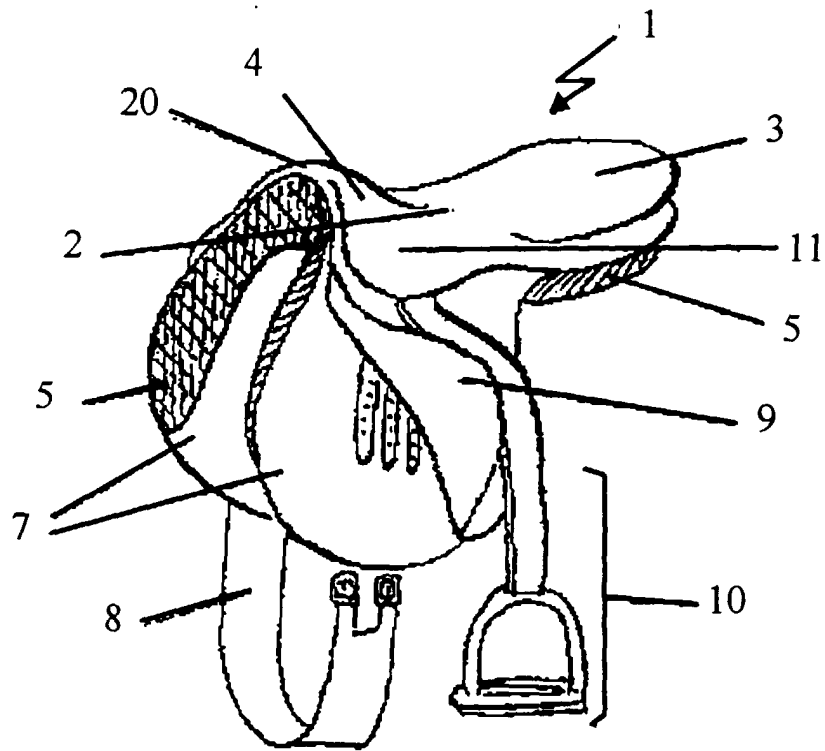

Figure 2

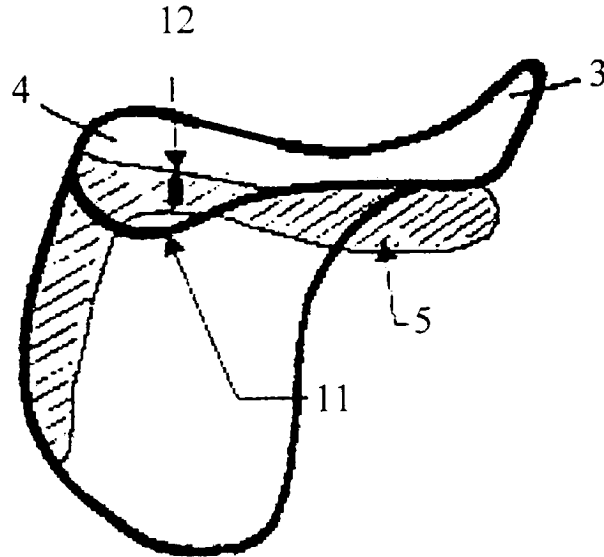

Figure 3

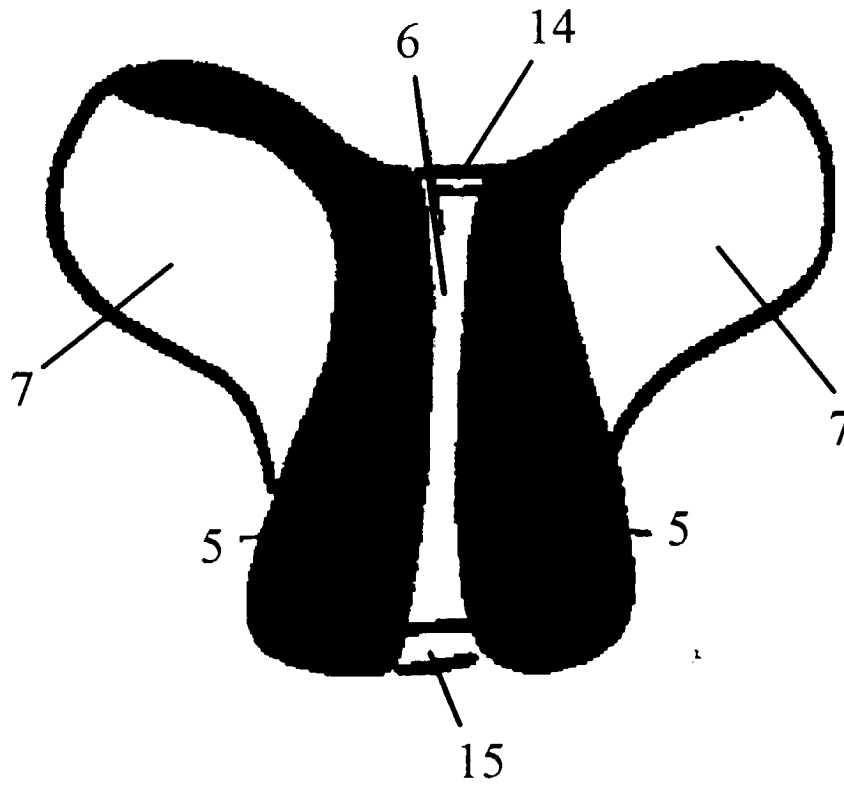

Figure 4

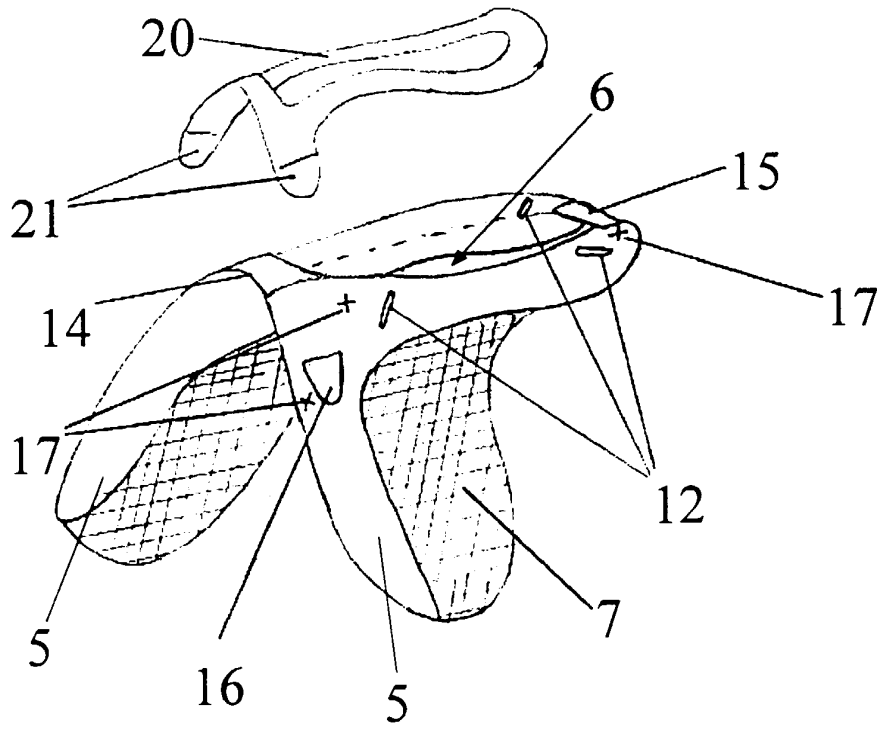

Figure 5

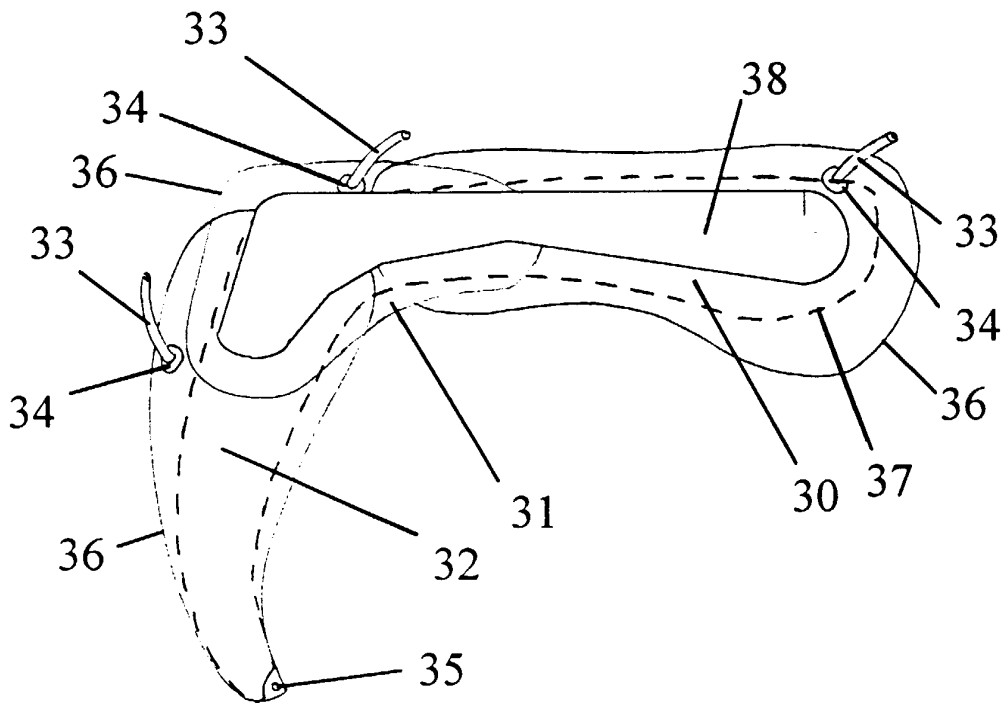

Figure 6

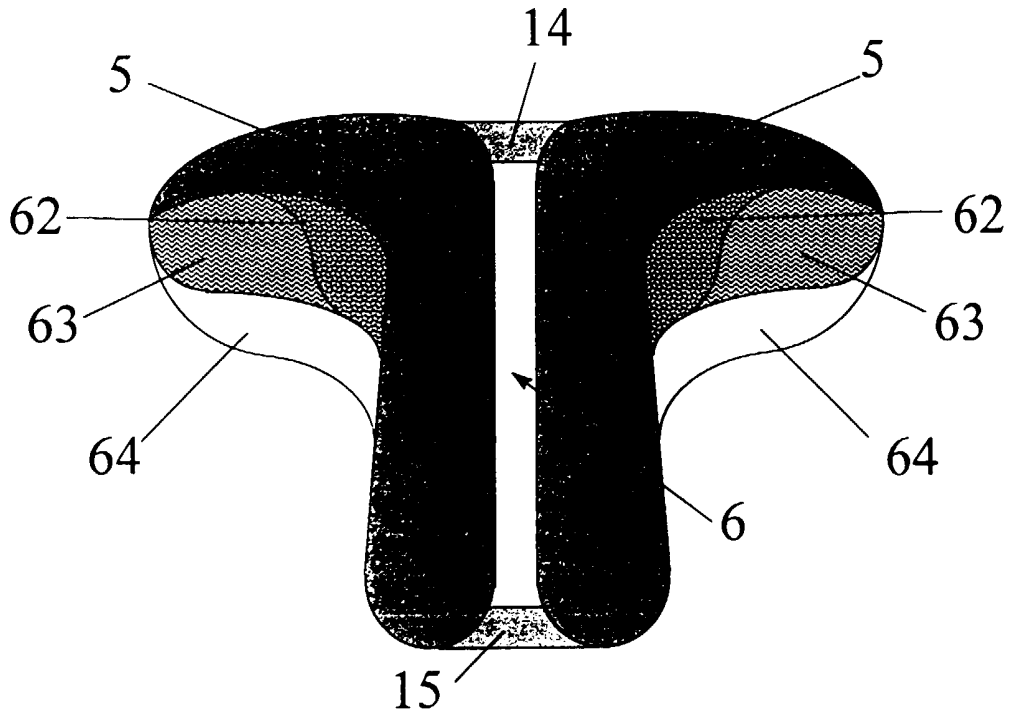
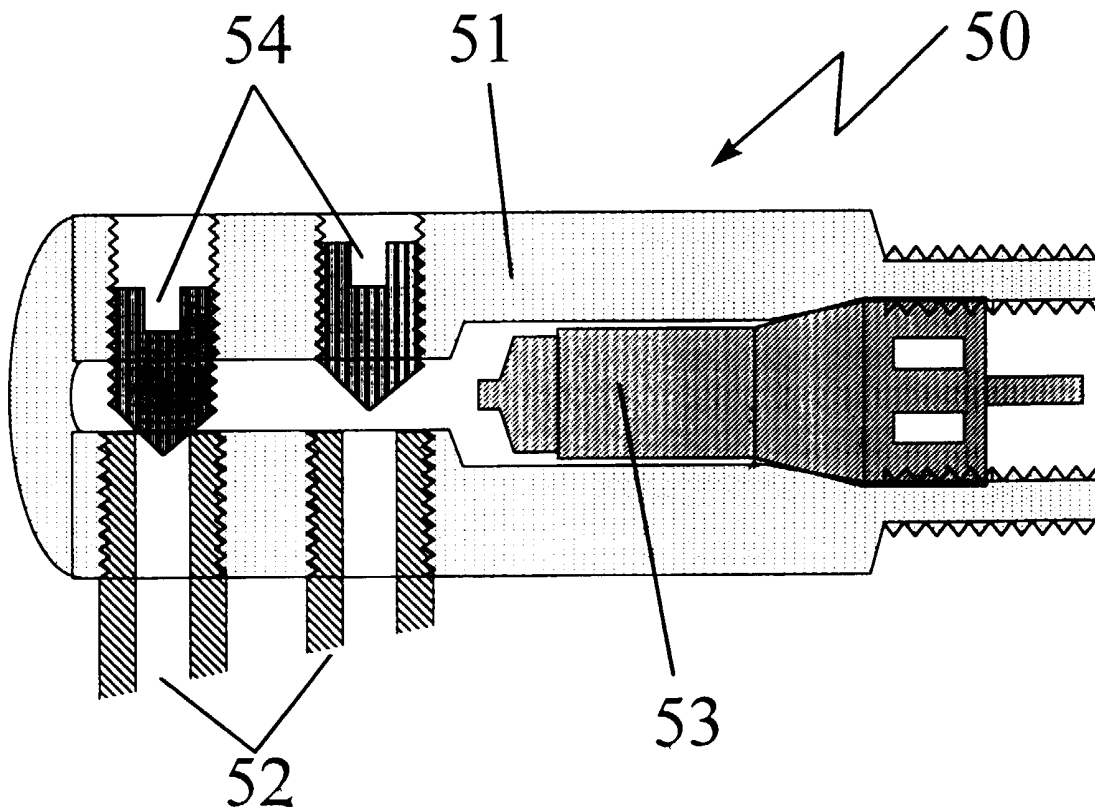

Figure 7



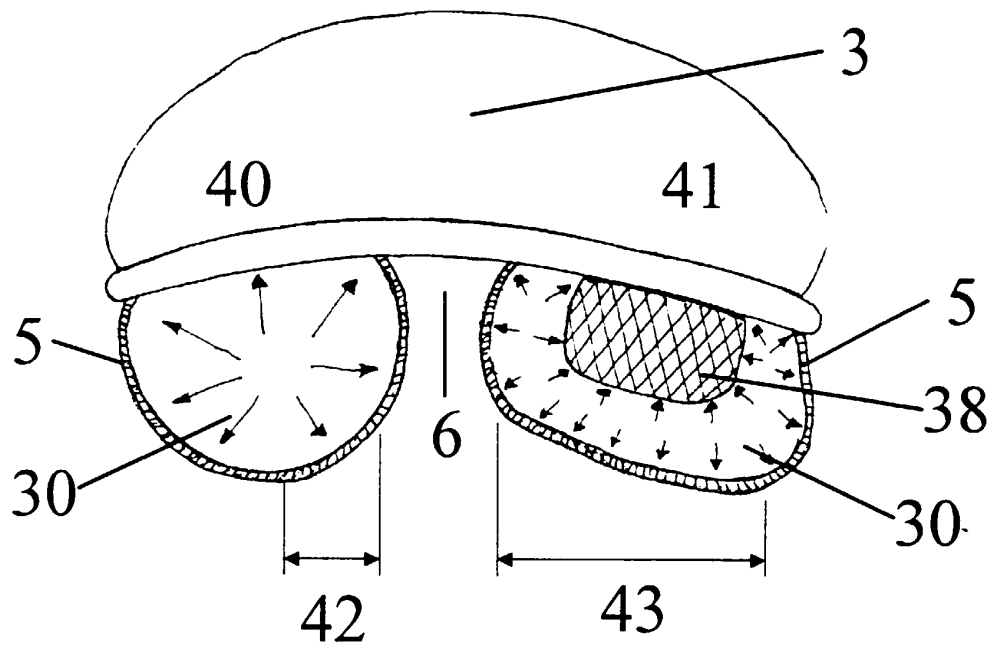

Figure 8

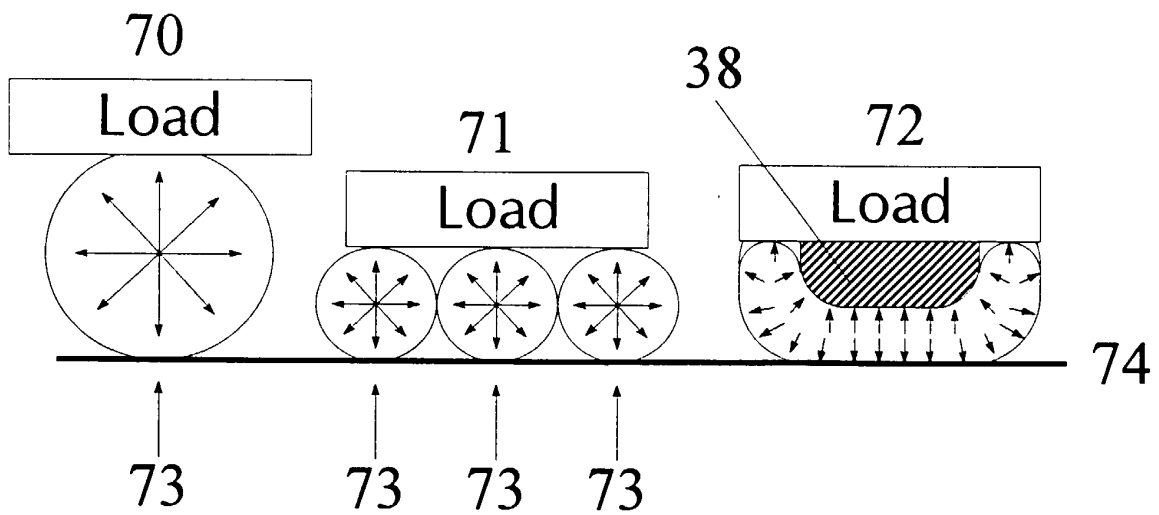

Figure 9