

(19)



Europäisches Patentamt

European Patent Office

Office européen des brevets



(11)

EP 0 765 248 B1

(12)

EUROPEAN PATENT SPECIFICATION

(45) Date of publication and mention of the grant of the patent:

02.12.1998 Bulletin 1998/49

(21) Application number: **95918396.3**

(22) Date of filing: **04.05.1995**

(51) Int. Cl.⁶: **B42D 1/10**, B42F 11/00

(86) International application number:
PCT/US95/05606

(87) International publication number:
WO 95/34431 (21.12.1995 Gazette 1995/54)

(54) **BINDING ASSEMBLY**

BINDEVORRICHTUNG

ENSEMBLE CLASSEUR

(84) Designated Contracting States:
DE FR GB IT

(30) Priority: **13.06.1994 US 258963**

(43) Date of publication of application:
02.04.1997 Bulletin 1997/14

(73) Proprietor:
MINNESOTA MINING AND MANUFACTURING COMPANY
St. Paul, Minnesota 55133-3427 (US)

(72) Inventors:
• **EMMEL, John J.**
Saint Paul, MN 55133-3427 (US)
• **BAYER, Glen H., Jr.**
Saint Paul, MN 55133-3427 (US)

- **WINDORSKI, David C.**
Saint Paul, MN 55133-3427 (US)
- **O'LEARY, Timothy J.**
Saint Paul, MN 55133-3427 (US)
- **MILLER-BRUNS, Mary Kay**
Saint Paul, MN 55133-3427 (US)

(74) Representative:
Hilleringmann, Jochen, Dipl.-Ing. et al
Patentanwälte
von Kreisler-Selting-Werner,
Bahnhofsvorplatz 1 (Deichmannhaus)
50667 Köln (DE)

(56) References cited:
EP-A- 0 459 645 **EP-A- 0 511 146**
GB-A- 2 279 914

EP 0 765 248 B1

Note: Within nine months from the publication of the mention of the grant of the European patent, any person may give notice to the European Patent Office of opposition to the European patent granted. Notice of opposition shall be filed in a written reasoned statement. It shall not be deemed to have been filed until the opposition fee has been paid. (Art. 99(1) European Patent Convention).

Description

The present invention relates to binding assemblies for use in binding together a plurality of loose sheets by adhering the sheets to layers of pressure sensitive adhesive on parts of assembly.

The art is replete with binding assemblies for use in binding together a plurality of loose sheets by adhering the sheets to layers of pressure sensitive adhesive on parts of assemblies. EP-A-0 511 146 A1 and WO-A-87/02941 provide illustrative examples. Heretofore, however, known binding assemblies of this type have included strips of release liner protecting the pressure sensitive adhesive that must be removed before the assembly is used, or the assemblies have had other features that make them less convenient to use than might be desired. In particular, EP-A-0 511 146 describes a binding assembly for use in binding together a plurality of loose sheets comprising a plurality of support sheets bound together along one respective edge. On the opposite edge, the sheets comprise strips of release liner protecting a pressure sensitive adhesive that must be removed before the assembly is used.

It is the object of the present invention to provide a binding assembly for use in binding together a plurality of loose sheets by adhering the sheets to layers of pressure sensitive adhesive on parts of assembly, use of which binding assembly does not require removal of strips of release liner, and which is otherwise more easily used to assemble and arrange loose sheets of paper.

According to the invention, this object is solved in a binding assembly as defined in claim 1. The subclaims relate to preferred embodiments, respectively.

The binding assembly according to the present invention generally comprises (1) a plurality of support strips; (2) layers of pressure sensitive adhesive (which could be repositionable, removable or permanent pressure sensitive adhesive) along front surfaces of the support strips; and (3) layers of release material on a rear surfaces of the support strips. The support strips are adhered together to form a support strip stack with inner edges of the support strips in alignment, with the layers of pressure sensitive adhesive on the support strips adhered to the layers of release material on adjacent support strips, and with the front surfaces of the support strips uppermost in the support strip stack. The binding assembly further includes binding means along the inner edges of the support strips that affords separation of the support strips and revolving of the support strips relative to each other around axes generally parallel to their inner edges. The relatively high stiffness of the support strips, the adhesive property of the layer of pressure sensitive adhesive, the level of adhesion between the layers of pressure sensitive adhesive and the layers of release material, and the relatively low resistance to pivotal movement of the support strips relative to each other caused by the binding means being selected so that only tension applied through a paper

sheet adhered along the full length of the layer of pressure sensitive adhesive on the uppermost one of the support strips adhered in the support strip stack can be used to separate that one support strip from an adjacent support strip adhered to the layer of release material on the front surface of that one support strip and cause revolving of that one support strip away from the support strip from which that one support strip was separated.

In one embodiment, that binding means along the inner edges of the support strips comprises, for each support strip, an elongate hinge strip that is significantly more flexible around a longitudinal axis than the support strip. The hinge strip has an attachment portion adjacent a first edge adhered along a portion of the support strip adjacent the inner edge of the support strip, an anchor portion adjacent a second opposite edge, and a central hinge portion between the attachment and anchor portions. The major surfaces of the anchor portions are attached together in an anchor stack adapted to have its lowermost surface adhered or otherwise secured to a substrate, and the hinge portions are independently bendable around axes extending longitudinally of the hinge strip to afford revolving of said one support strip away from the support strip from which the one support strip was separated.

In another embodiment, that binding means along the inner edges of the support strips comprises a layer of flexible hot melt adhesive adhered along the inner edges of the support strips; and in yet another embodiment adapted for use in three ring binders that binding means comprises a plurality of aligned through openings in the support strips adapted to be received on and slide along spaced annular rings disposed about a common axis.

The outer edge of each support strip in the support strip stack can project past the outer edge of the next lowermost support strip in the support strip stack by a distance in the range of about 0.02032 to 0.16002 cm (0.008 to 0.063 inch) (preferably by about 0.0381 cm (0.015 inch)) which facilitates separating the support strips from each other. The binding assembly can further include means on the anchor stack adapted to attach the anchor stack to a substrate, which means can be a layer of pressure sensitive adhesive or a hook portion of a hook and loop fastener, or both. Also, the binding assembly can include means on the top of the anchor stack (such as the loop portion of a hook and loop fastener) adapted to have attached thereto the bottom of the anchor stack of another one of the binding assemblies. The binding assembly can further include an elongate cover strip with a layer of release material on its rear surface, which cover strip is adhered to the top support strip in the stack with their inner edges aligned, and with the layer of pressure sensitive adhesive on the top support strip adhered to the layer of release material on the cover strip, and the binding means can include means along the inner edge of the

cover strip for affording separation of the cover strip and revolving of the cover strip relative to the top support strip around axes generally parallel to the inner edges. The significant stiffness of the cover strip, the level of adhesion between the layer of pressure sensitive adhesive on the top support strip and the layer of release material on the cover strip, and the relatively low resistance to pivotal movement of the cover strip relative to the support strips caused by the binding means are selected so that the cover strip can be easily manually separated from the layer of pressure sensitive adhesive on the top support strip and revolved away from the top support strip by simply engaging the cover strip along one edge.

The length of the cover strip and its width between its inner and outer edges can be essentially the same as the length and width of the support strips, or, alternatively, or can be substantially greater than the length and width of the support strips.

Also, the binding assembly can further include a backing member and the binding means along the inner edges of the support strips can be attached along a front surface of the backing member, and that backing member can be a rear portion of a cover which can also include a front portion attached so that it can be moved relative to the rear portion between open and closed positions.

The present invention will be further described with reference to the accompanying drawing wherein like reference numerals refer to like parts in the several views, and wherein:

Figure 1 is a perspective view of a first embodiment of a binding assembly according to the present invention;

Figure 2 is an end view of a sheet bound on the binding assembly of Figure 1 being used to separate a support sheet to which the sheet is releasably adhered from other support sheets in a support sheet stack;

Figure 3 is a perspective view of a second embodiment of a binding assembly according to the present invention;

Figure 4 is a perspective view of a third embodiment of a binding assembly according to the present invention;

Figure 5 is an end view of three binding assemblies of the embodiment illustrated in Figure 4 stacked and attached together;

Figure 6 is a perspective view of a fourth embodiment of a binding assembly according to the present invention;

Figure 7 is a side view of a fifth embodiment of a binding assembly according to the present invention;

Figure 8 is a top view of the binding assembly illustrated in Figure 7;

Figure 9 is a perspective view of the binding assem-

bly of Figure 6 attached in a first type of folder;

Figure 10 is a perspective view of the binding assembly of Figure 6 attached in a second type of folder;

Figure 11 is a perspective view of a sixth embodiment of a binding assembly according to the present invention; and

Figure 12 is a perspective view of a seventh embodiment of a binding assembly according to the present invention.

Referring now to Figures 1 and 2 of the drawing, there is shown a first embodiment of a binding assembly according to the present invention generally designated by the reference numeral 10, which binding assembly 10 is adapted for binding together a plurality of loose sheets.

Generally the binding assembly 10 comprises a plurality of support strips 12 of a fairly stiff flexible material (e.g., of paper or polymeric material). Each of the support strips 12 has front and rear major surfaces 13 and 14, opposite inner and outer edges 15 and 16, and opposite ends 17. Also each of the support strips 12 has a layer 18 of pressure sensitive adhesive (which could be repositionable, removable or permanent pressure sensitive adhesive depending on the desired application of the binding assembly 10) adhered along its front surface 13, and a layer 20 of release material on its rear surface 14. The support strips 12 are adhered together to form a support strip stack 22 with the inner edges 15 of the support strips 12 in alignment, with the layers 18 of pressure sensitive adhesive on the support strips 12 adhered to the layers 20 of release material on adjacent support strips 12, and with the front surfaces 13 of the support strips 12 uppermost in the support strip stack 22. The binding assembly 10 further includes binding means 24 along the inner edges 15 of the support strips 12 for affording separation of the support strips 12 and revolving of the support strips 12 relative to each other around axes generally parallel to the inner edges 15. The stiffness of the support strips 12 (e.g., a Tabor stiffness value of about 2.638 gram centimeter), the adhesive property of the layer of pressure sensitive adhesive (e.g., a peel value of about 4.6 Newton/Decimeter), the level of adhesion between the layers 18 of pressure sensitive adhesive and the layers 20 of release material (e.g., a peel value of about 0.57 Newton/Decimeter), and the resistance to pivotal movement of the support strips 12 relative to each other caused by the binding means 24 (e.g., about 0.73 Newton/Decimeter) are selected so that only tension applied through a paper sheet 25 (see Figure 2) adhered along the full length of the layer 18 of pressure sensitive adhesive on one of the support strips 12 can be used to separate that one support strip 12 from an adjacent support strip 12 adhered to the layer 18 of release material on the rear surface 14 of that one support strip 12 and cause revolving of that one support strip 12 away from the

underlying support strip 12 from which that one support strip 12 was separated.

The outer edge 16 of each support strip 12 in the support strip stack 22 projects past the outer edge 16 of the next lowermost support strip 12 in the support strip stack 22 by a distance in the range of about 0.02032 to 0.16002 cm (0.008 to 0.063 inch) (e.g., 0.0381 cm (0.015 inch)) which facilitates separating the uppermost support strip 12 from the other supports strips 12 forming the support strip stack 12.

The binding means 24 along the inner edges 15 of the support strips 12 comprises, for each support strip 12, an elongate hinge strip 26 that is significantly more flexible around a longitudinal axis than the support strips 12 (e.g., a Tabor stiffness of about 0.1236 gram centimeter). Each hinge strip 26 has opposite major surfaces, opposite first and second edges 29 and 30, an attachment portion 31 adjacent the first edge 29 adhered along a portion of the support strip 12 adjacent the inner edge 15 of the support strip 12, an anchor portion 32 adjacent the second edge 30, and a central hinge portion between the attachment and anchor portions 31 and 32. The anchor portions 32 are attached or adhered together, major surface to major surface, to form an anchor stack 34, and the hinge portions are independently bendable around axes extending longitudinally of the hinge strip 26 to afford revolving of the one support strip 12 away from the support strip 12 from which that one support strip 12 was separated. The anchor stack 34 is adapted to be secured to a substrate by a layer 36 of a suitable permanent pressure sensitive adhesive along the bottom surface of the lowermost anchor portion in the anchor stack 34.

An example of materials for use in the binding assembly 10 described above (and in those alternate embodiments thereof described below) are as follows. The support strips 12 can be made of polyester in the range of 0.00762 to 0.01524 cm (0.003 to 0.006 inch) thick. The pressure sensitive adhesive can be a repositionable acrylate pressure sensitive adhesive such as the isooctylacrylate/octyldecylacrylate/amine bis phenone pressure sensitive adhesive described in EP 0 619 830. The release material can be a premium silicone release material with a release value of 14.175 g to 170.1 g (0.5 to 6 ounces). The material from which the hinge strips are made should be significantly more flexible than the material from which the support strips 12 are made, such as a 0.00508 cm (0.002 inch) thick polyethylene backing material which can be adhered together in the anchor stack 34 and adhered to the support strips 12 by layers of acrylate high tack pressure sensitive adhesive 0.0381 to 0.01016 cm (0.0015 to 0.004 inch) thick.

To use the binding assembly 12 to bind several sheets, an edge portion of a first sheet to be bound is adhered along the layer 18 of pressure sensitive adhesive on the uppermost support strip 12 in the support strip stack 22. Tension applied through that first sheet

can then be used to peel that uppermost support strip 12 away from the layer 18 of pressure sensitive adhesive on the next lower support strip 12 in the support strip stack 22, as is illustrated in Figure 2 with the sheet 25, thereby exposing that layer 18 of adhesive so that a second sheet to be bound can be adhered to it. Subsequently tension applied through that second sheet can be used to peel that next lower support strip 12 away from the layer 18 of pressure sensitive adhesive on the yet next lower support strip 12 in the support strip stack 22 thereby exposing that layer 18 of adhesive so that a third sheet can be adhered to it. In this manner, the layers 18 of adhesive on as many of the support strips 12 as needed can be used to bind sheets together. If a user desires to remove or replace an already bound sheet, the user simply peels that sheet from the layer 18 of adhesive and either allows that layer 18 of adhesive to again adhere to the layer 20 of release material on the adjacent support strip 12 or adheres the replacement sheet to it.

Various modifications of the binding assembly 10 according to the present invention are illustrated in Figures 3 through 12 in which similar structural elements to those described above with reference to the Figures 1 and 2 are identified with similar reference numerals to which has been added one of the suffixes "a" through "d".

Figures 3 and 4 illustrate two binding assemblies 38 and 40 that include various means on the anchor stack 34a or 34b other than the layer 36 of adhesive that are adapted to attach the anchor stack 34a and 34b to a substrate.

Figure 3 illustrates the binding assembly 38 in which that means is both a layer 42 of pressure sensitive adhesive along a layer of foam 43, and a hook portion 44 of a hook and loop fastener (e.g., the hook portion described in US-A-5,116,563). The use of both the layer 42 of pressure sensitive adhesive and the hook portion 44 affords attaching the binding assembly either to a smooth surface, or to a loop portion of such a fastener, or to various structures with loops along their surfaces such as the walls of certain types of office partitions.

Figure 4 illustrates the binding assembly 40 in which that means is a hook portion 46 of a hook and loop fastener and which further includes means on the top surface of its anchor stack 34b in the form of a loop portion 47 of a hook and loop fastener (e.g., open woven or nonwoven textile fabric) adapted to have attached thereto the anchor stack 34b of another one of the binding assemblies 40. Figure 5 illustrates binding together three of the binding assemblies 40 which together can bind many more loose sheets than can be bound with only one binding assembly 40. The lowest binding assembly 40 can be attached to a layer of loop material (not shown).

Figure 6 illustrates a binding assembly 50 including an elongate cover strip 52 for protecting the layer 18 of

adhesive on the uppermost support strip 12c before a sheet is attached to it. The cover strip 52 has front and rear major surfaces 53 and 54, opposite inner and outer edges 55 and 56, and opposite ends 57. A layer of release material 58 is adhered on the rear surface 54 of the cover strip 52; and the cover strip 52 is adhered to the top support strip 12c in the support stack 22c with the inner edge 55 of the cover strip 52 aligned with the inner edges 15c of the support strips 12c, and with the layer 18c of pressure sensitive adhesive on the top support strip 12c adhered to the layer of release material 58 on the cover strip 52. The binding means including means along the inner edge 55 of the cover strip 52 for affording separation of the cover strip 52 and revolving of the cover strip 52 relative to the top support strip 12c around axes generally parallel to the inner edges 55 and 15c; and the stiffness of the cover strip 52, the level of adhesion between the layer 18c of pressure sensitive adhesive on the top support strip 12c and the layer of release material 58 on the cover strip 52, and the resistance to pivotal movement of the cover strip 52 relative to the support strips 12c caused by the binding means are selected so that the cover strip 52 can be easily manually separated from the layer 18c of pressure sensitive adhesive on the top support strip 12c and revolved away from the top support strip 12c by engaging the cover strip 52 along one edge. As illustrated in Figure 6, the width of the cover strip 52 between its inner and outer edges 55 and 56, and the length of the cover strip 52 between its opposite ends 57 are essentially the same as the widths and lengths of the support strips 12c. The materials of the cover strip 52 and in the layer 58 of release material can be the same as the material of the support strips 12 and in the layer 20 of release material described above. Use of the binding assembly 50 is essentially the same as the use of the binding assembly 10 described above, except that before the first sheet to be bound is adhered along the layer 18c of pressure sensitive adhesive on the uppermost support strip 12c in the support strip stack 22c, the cover strip 52 must be separated from it, which can easily be done by engaging the cover strip 52 along its outer edge 56 and peeling it away.

Figures 7 and 8 illustrate a binding assembly 60 having a cover strip 62 in which the width of the cover strip 62 between its inner and outer edges 63 and 64 is substantially greater than the width of the support strips 12d between their inner and outer edges 15d and 16d; and the length of the cover strip 60 between its opposite ends 66 is significantly greater than the lengths of the support strips 12d between their ends 17d so that the cover strip 62 provides a cover for documents adhered to the binding assembly 60. As is illustrated, the cover strip 62 can be transparent, and the binding assembly 60 can further include a backing member 67 that is slightly larger than the cover strip 62, has a front surface to which the anchor stack 34d is attached, and has the hook portion 70 of a hook and loop fastener attached

along its rear surface 69 by which the backing member 67 can be releasably attached to loop material. Thus, the binding assembly 60 can be attached by the hook portion 70 to a loop material such as that on the wall of a cubicle divider.

Figure 9 illustrates the binding assembly 50 of Figure 6 having its anchor stack 34c adhered to a backing member 52a, which backing member 52a is a rear portion of a cover or folder 53a including a rear portion and a front portion. The front and rear portions and of the folder 53a are joined and folded along adjacent edges 56a to afford movement of the front portion relative to the rear portion from a closed position overlaying the rear portion, to an open position spaced from the rear portion as illustrated. The anchor stack 34c of the binding assembly 50 extends along the folded edges 56a with the support strip stack 22c on the side of the anchor stack 34c opposite the folded edges 56a. The folder 53a is of the type commonly used to carry travel documents particularly including airline tickets, and may be made of any suitable paper or polymeric material (e.g., 0.0245 cm (0.010 inch) thick polyethylene terephthalate). The binding assembly 50 is particularly useful in such a folder 53a as it affords binding together various types and sizes of documents accumulated while traveling, such as ticket stubs, and various receipts for parking, taxis, hotels and the like.

Figure 10 illustrates the binding assembly 50 of Figure 6 having its anchor stack 34c adhered to a backing member 62a which is a rear portion of a cover or folder 63a including the rear portion and a front portion. The front and rear portions and are joined and folded along a common aligned edge or fold 66a to afford movement of the cover portion relative to the rear portion from a closed position overlaying the rear portion, to an open position spaced from the rear portion as illustrated. The binding assembly 50 extends at a right angle to the fold 66a along one end of the rear portion of the folder 63a. The folder 63a is of the type commonly used to collect larger documents (e.g., typically 21.59 by 27.94 cm (8 and one half by 11 inches in size)) relating to a single subject, and may be made of any suitable paper or polymeric material.

Figure 11 illustrates a binding assembly 80 according to the present invention which, like the binding assembly 10, includes a plurality of support strips 12e, each of which has as a layer 18e of pressure sensitive adhesive (which could be repositionable, removable or permanent pressure sensitive adhesive) adhered along its front surface, and a layer 20e of release material on its rear surface, which support strips 12e are adhered together to form a support strip stack 22e with the inner edges of the support strips 12e generally in alignment, with the layers 18e of pressure sensitive adhesive on the support strips 12e adhered to the layers 20e of release material on adjacent support strips 12e, and with the front surfaces of the support strips 12e uppermost in the support strip stack 22. Also, the binding

assembly 80 further includes binding means 24e along the inner edges of the support strips 12e for affording separation of the support strips 12e and revolving of the support strips 12e relative to each other around axes generally parallel to the inner edges. Unlike the binding assembly 10, however, in the binding assembly 80 that binding means 24e comprises a layer 82 of flexible hot melt adhesive adhered along the inner edges 15e and an adjacent portion of the front surface of the support strips 12, which layer 82 of hot melt adhesive will not adhere to the layers 20e of release material on the support strips 12e. A suitable hot melt adhesive for forming that layer 82 is ethylene vinyl acetate such as that sold under the trade designation "Elvax" (R.T.M.) by DuPont Chemical Company, Wilmington, Delaware, or that sold under the trade designation "Ultrathene" (R.T.M.) by Quantum Chemical Corp., USI Division, Cincinnati, Ohio.

Figure 12 illustrates a binding assembly 90 according to the present invention which generally comprises a plurality of support strips 92 of a fairly stiff flexible material (e.g., of the same material as the support strips 12). Each of the support strips 92 has front and rear major surfaces 93 and 94, opposite inner and outer edges 95 and 96, and opposite ends 97. Also each of the support strips 92 has a layer 98 of pressure sensitive adhesive adhered along its front surface 93, and a layer 100 of release material on its rear surface 94. The support strips 92 are adhered together to form a support strip stack 102 with the inner edges 95 of the support strips 92 in alignment, with the layers 98 of pressure sensitive adhesive on the support strips 92 adhered to the layers 100 of release material on adjacent support strips 92, and with the front surfaces 93 of the support strips 92 uppermost in the support strip stack 102. The binding assembly 90 further includes binding means 104 along the inner edges 95 of the support strips 92 for affording separation of the support strips 92 and revolving of the support strips 92 relative to each other around axes generally parallel to the inner edges 95. The stiffness of the support strips 92, the adhesive property of the layer 98 of pressure sensitive adhesive, the level of adhesion between the layers of pressure sensitive adhesive and the layers 100 of release material, and the resistance to pivotal movement of the support strips 92 relative to each other caused by the binding means 104 are selected so that only tension applied through a paper sheet (not shown) adhered along the full length of the layer 98 of pressure sensitive adhesive on one of the support strips 92 can be used to separate that one support strip 92 from an adjacent support strip 92 adhered to the layer 98 of release material on the rear surface 94 of that one support strip 92 and cause revolving of that one support strip 92 away from the underlying support strip 92 from which that one support strip 92 was separated.

In the binding assembly 90, the binding means 104 along the inner edges 95 of the support strips 92 for

affording separation of the support strips 92 and revolving of the support strips 92 relative to each other around axes generally parallel to the inner edges 95 comprises a plurality of aligned through openings 105 in the support strips 12 adapted to be received on and slide along spaced annular rings (not illustrated) disposed about a common axis, and the openings 105 are spaced so that the binding assembly 90 is adapted for use on the rings of a three ring binder. If desired, a cover strip (not illustrated) could also be provided on the binding assembly 90. Use of the binding assembly 90 without or with the cover strip would be essentially the same as the use of the binding assemblies 10 and 50 described above.

Claims

1. A binding assembly for binding a plurality of loose sheets together, said binding assembly comprising;

a plurality of support strips (12, 92) each of which support strips (12, 92) has front and rear major surfaces (13, 14, 93, 94), opposite inner and outer edges (15, 16, 95, 96), and opposite ends (17, 97);

a layer (18, 98) of pressure sensitive adhesive along said front surface (13, 93) of said support strip (12, 92);

a layer (20, 100) of release material on the rear surface (14, 94) of said support strip (12, 92);

said support strips (12, 92) being adhered together to form a support strip stack (22) with said inner edges (15, 95) of said support strips (12, 92) in alignment, with the layers (18, 98) of pressure sensitive adhesive on the support strips (12, 92) adhered to the layers (20, 100) of release material on adjacent support strips (12, 92), and with the front surfaces (13, 93) the support strips (12, 92) uppermost in the stack (22);

said binding assembly further including binding means (24, 104) along said inner edges of said support strips (12, 92) for affording separation of said support strips (12, 92) and revolving of said support strips (12, 92) relative to each other around axes generally parallel to said inner edges (15, 95);

the stiffness of said support strips (12, 92), the adhesive property of the layer (18, 98) of pressure sensitive adhesive, the level of adhesion between said layers (18, 98) of pressure sensitive adhesive and said layers (20, 100) of release material, and the resistance to pivotal movement of said support strips (12, 92) relative to each other caused by said binding means (24, 104) being selected so that only

tension applied through a paper sheet (25) adhered along the full length of the layer (18, 98) of pressure sensitive adhesive on one of the support strips (12, 92) can be used to separate that one support strip (12, 92) from an adjacent support strip (12, 92) adhered to the layer (20, 100) of release material on the surface of that one support strip (12, 92) and cause revolving of that one support strip (12, 92) away from the support strip (12, 92) from which said one support strip (12, 92) was separated.

2. A binding assembly according to claim 1 wherein the outer edge of each support strip (12, 92) in the support strip stack (22) projects past the outer edge of the next lowermost support strip (12, 92) in the support strip stack (22) by a distance in the range of about 0.02032 to 0.16002 cm (0.008 to 0.063 inch).
3. A binding assembly according to claim 1 or 2 wherein said binding means (24, 104) along said inner edges (15, 95) of said support strips (12, 92) for affording separation of said support strips (12, 92) and revolving of said support strips (12, 92) relative to each other around axes generally parallel to said inner edges (15, 95) comprises, for each support strip (12, 92), an elongate hinge strip (26) that is significantly more flexible around a longitudinal axis than said support strip (12, 92), said hinge strip (26) having opposite major surfaces, opposite first and second edges (29, 30), an attachment portion (31) adjacent said first edge (29) adhered along a portion of said support strip (12, 92) adjacent the inner edge (15) of said support strip (12, 92) an anchor portion (32) adjacent said second edge (30), and a central hinge portion between said attachment and anchor portions (31, 32), said anchor portions (32) being attached together in an anchor stack (34) adapted to be secured to a substrate and said hinge strip (26) being independently bendable around axes extending longitudinally of said hinge strip (26) to afford revolving of said one support strip (12, 92) away from the support strip (12, 92) from which said one support strip (12, 92) was separated.
4. A binding assembly according to any one of claims 1 to 3 wherein said binding means (24) along said inner edges (15) of said support strips (12) for affording separation of said support strip (12) and revolving of said support strips (12) relative to each other around axes generally parallel to said inner edges (15) comprises a layer (82) of flexible hot melt adhesive adhered along the inner edges (15) of said support strips (12).

5. A binding assembly according to claim 1 wherein

said binding means (104) along said inner edges (95) of said support strips (92) for affording separation of said support strips (92) and revolving of said support strips (92) relative to each other around axes generally parallel to said inner edges (95) comprises a plurality of aligned through openings (105) in said support strips (92) adapted to be received on and slide along spaced annular rings disposed about a common axis.

6. A binding assembly according to any one of claims 1 to 3 further including means (44, 46, 70) on said anchor stack (34) adapted to attach said anchor stack (34) to a substrate.
7. A binding assembly according to any one of claims 1 to 3 further including means (44, 46, 70) on said anchor stack (34) adapted to attach said anchor stack to a substrate and means (47) on said substrate adapted to have attached thereto the anchor stack of another one of said binding assemblies.
8. A binding assembly according to any one of claims 1 to 7 further including an elongate cover strip (52, 62) having front and rear major surfaces (53, 54), opposite inner and outer edges (55, 56, 63, 64), and opposite ends (57, 66);

a layer of release material (58) on the rear surface (54) of said cover strip (52, 62); said cover strip (52, 62) being adhered to the top support strip (12) in said stack (22) with the inner edge (55, 63) of said cover strip (52, 62) aligned with the inner edges (15) of said support strips (12) and with the layer (18) of pressure sensitive adhesive on said top support strip (12) adhered to the layer (58) of release material on the cover strip (52, 62); said binding means (24) including means along said inner edge of said cover strip (52, 62) for affording separation of said cover strip (52, 62) and revolving of said cover strip (52, 62) relative to said top support strip (12) around axes generally parallel to said inner edges (15) the stiffness of said cover strip (52, 62), the level of adhesion between the layer (18) of pressure sensitive adhesive on said top support strip (12) and said layer (54) of release material on said cover strip (52, 62), and the resistance to pivotal movement of said cover strip (52, 62) relative to said support strips (12) caused by said binding means (24) being selected so that said cover strip (52, 62) can be easily manually separated from the layer (18) of pressure sensitive adhesive on said top support strip (12) and revolved away from the top support strip (12) by engaging the cover strip (52, 62) along one edge.

9. A binding assembly according to any one of claims 1 to 8 further including a backing member (67) having front and rear surfaces with said binding means along said inner edges (15) of said support strips (12) being attached along the front surface of said backing member (67). 5
10. A binding assembly according to any one of claims 1 to 9 wherein said layers (18, 98) of pressure sensitive adhesive along said front surfaces (13, 93) of said support strips (12, 92) are of repositionable pressure sensitive adhesive. 10
11. A binding assembly according to any one of claims 1 to 9 wherein said layers (18, 98) of pressure sensitive adhesive along said front surfaces (13, 93) of said support strips (12, 92) are of removable pressure sensitive adhesive. 15
12. A binding assembly according to any one of claims 1 to 11 wherein said layers (18, 98) of pressure sensitive adhesive along said front surfaces (13, 93) of said support strips (12, 92) are of permanent pressure sensitive adhesive. 20

Patentansprüche

1. Bindevorrichtung zum Zusammenbinden mehrerer loser Blätter, mit: 25
- mehreren Haltestreifen (12,92), von denen jeder vordere und rückwärtige Hauptflächen (13,14,93,94), einander gegenüberliegende innere und äußere Ränder (15,16,95,96) und einander gegenüberliegende Enden (17,97) aufweist; 30
- einer entlang der vorderen Fläche (13,93) des Haltestreifens (12,92) angeordnete Lage (18,98) aus Haftkleber; 35
- einer an der rückwärtigen Fläche (14,94) des Haltestreifens (12,92) angeordneten Lage (20,100) aus klebkraftabweisendem Material, 40
- wobei zwecks Bildung eines Haltestreifen-Stapels (22) die Haltestreifen (12,92) aneinander anhaften, und zwar bei Ausrichtung der inneren Ränder (15,95) der Haltestreifen (12,92), bei Anhaftung der auf den Haltestreifen (12,92) angeordneten Lagen (18,98) aus Haftkleber an auf benachbarten Haltestreifen (12,92) angeordneten Lagen (20,100) aus klebkraftabweisendem Material, und mit nach oben weisenden vorderen Flächen (13,93) der Haltestreifen (12,92) auf dem Stapel (22); 45
- wobei die Bindevorrichtung ferner entlang der 55

inneren Ränder der Haltestreifen (12,92) eine Bindeeinrichtung (24, 104) aufweist, um eine Trennung der Haltestreifen (12,92) und eine Schwenkung der Haltestreifen (12,92) relativ zueinander um im wesentlichen parallel zu den inneren Rändern (15,95) verlaufende Achsen zu ermöglichen;

wobei die Steifigkeit der Haltestreifen (12,92), die Klebeeigenschaft der Lage (18,98) aus Haftkleber, der Grad an Anhaftung zwischen den Lagen (18,98) aus Haftkleber und den Lagen (20,100) aus klebkraftabweisendem Material und der durch die Bindeeinrichtung (24,104) verursachte Widerstand gegen eine relativ zueinander erfolgende Schwenkbewegung der Haltestreifen (12,92) derart gewählt sind, daß nur eine Spannung, die durch ein entlang der vollen Länge der Lage (18,98) aus Haftkleber an einem der Haltestreifen (12,92) anhaftendes Papierblatt (25) aufgebracht wird, verwendet werden kann, um diesen einen Haltestreifen (12,92) von einem benachbarten Haltestreifen (12,92), der an der Lage (20,100) aus klebkraftabweisendem Material an der Oberfläche dieses einen Haltestreifens (12,92) anhaftet, zu trennen, und um zu bewirken, daß dieser eine Haltestreifen (12,92) von demjenigen Haltestreifen (12,92), von dem der eine Haltestreifen (12,92) getrennt wurde, weg geschwenkt wird.

2. Bindevorrichtung nach Anspruch 1, bei der der äußere Rand jedes Haltestreifens (12,92) in dem Haltestreifen-Stapel (22) über den äußeren Rand des nächstunteren Haltestreifens (12,92) in dem Haltestreifen-Stapel (22) um eine Distanz im Bereich von ungefähr 0,02032 bis 0,16002 cm (0,008 bis 0,063 inch) vorsteht.
3. Bindevorrichtung nach Anspruch 1 oder 2, bei der die entlang der inneren Ränder (15,95) der Haltestreifen (12,92) angeordnete Bindeeinrichtung (24,104), die zur Ermöglichung einer Trennung der Haltestreifen (12,92) und einer Schwenkung der Haltestreifen (12,92) relativ zueinander um im wesentlichen parallel zu den inneren Rändern (15,95) verlaufende Achsen vorgesehen ist, für jeden Haltestreifen (12,92) einen länglichen Scharnierstreifen (26) aufweist, der um eine Längsachse herum wesentlich flexibler ist als der Haltestreifen (12,92), wobei der Scharnierstreifen (26) einander entgegengesetzte Hauptflächen, einander gegenüberliegende erste und zweite Ränder (29,30), ein nahe dem ersten Rand (29) angeordnetes Befestigungsteil (31), das entlang eines nahe dem inneren Rand (15) des Haltestreifens (12,92) gelegenen Abschnitt des Haltestreifens (12,92) anhaftet, einen

Verankerungsteil (32) nahe dem zweiten Rand (30), und ein zwischen den Befestigungs- und Verankerungsteilen (31,32) angeordnetes zentrales Scharnierstück aufweist, wobei die Verankerungsteile (32) zu einem Verankerungs-Stapel (34) miteinander verbunden sind, der an einem Substrat befestigt werden kann, und wobei die Scharnierstreifen (26) unabhängig um in Längsrichtung des Scharnierstreifens (26) verlaufende Achsen biegsam sind, um zu bewirken, daß der eine Haltestreifen (12,92) von demjenigen Haltestreifen (12,92), von dem der eine Haltestreifen (12,92) getrennt wurde, weg geschwenkt wird.

4. Bindevorrichtung nach einem der Ansprüche 1 bis 3, bei der die entlang der inneren Ränder (15) der Haltestreifen (12) angeordnete Bindeeinrichtung (24), die zur Ermöglichung einer Trennung der Haltestreifen (12) und einer Schwenkung der Haltestreifen (12) relativ zueinander um im wesentlichen parallel zu den inneren Rändern (15) verlaufende Achsen vorgesehen ist, eine Lage (82) aus flexiblem heißschmelzendem Kleber aufweist, die entlang der inneren Ränder (15) der Haltestreifen (12) anhaftet.
5. Bindevorrichtung nach Anspruch 1, bei der die entlang der inneren Ränder (95) der Haltestreifen (92) angeordnete Bindeeinrichtung (104), die zur Ermöglichung einer Trennung der Haltestreifen (92) und einer Schwenkung der Haltestreifen (92) relativ zueinander um im wesentlichen parallel zu den inneren Rändern (95) verlaufende Achsen vorgesehen ist, in den Haltestreifen (92) mehrere ausgerichtete Durchgangsöffnungen (105) aufweist, die in der Lage sind, an beabstandeten kreisförmigen Ringen, die um eine gemeinsame Achse angeordnet sind, aufgenommen zu werden und an ihnen entlang zu gleiten.
6. Bindevorrichtung nach einem der Ansprüche 1 bis 3, ferner mit einer an dem Verankerungs-Stapel (34) angeordneten Einrichtung (44,46,70) zur Befestigung des Verankerungs-Stapels (34) auf einem Substrat.
7. Bindevorrichtung nach einem der Ansprüche 1 bis 3, ferner mit einer an dem Verankerungs-Stapel (34) angeordneten Einrichtung (44,46,70) zur Befestigung des Verankerungs-Stapels auf einem Substrat, und einer an dem Substrat angeordneten Einrichtung (47), an der der Verankerungs-Stapel einer weiteren der Bindevorrichtungen befestigbar ist.
8. Bindevorrichtung nach einem der Ansprüche 1 bis 7, ferner mit einem länglichen Abdeckstreifen (52,62) mit vorderen und rückwärtigen Hauptflä-

chen (53,54), einander gegenüberliegenden inneren und äußeren Rändern (55,56,63,64) und einander gegenüberliegenden Enden (57,66);

- einer an der rückwärtigen Fläche (54) des Abdeckstreifens (52,62) angeordneten Lage (58) aus klebekraftabweisendem Material, wobei der Abdeckstreifen (52,62) an dem oberen Haltestreifen (12) in dem Stapel (22) anhaftet und dabei der innere Rand (55,63) des Abdeckstreifens (52,62) mit den inneren Rändern (15) der Haltestreifen (12) ausgerichtet ist und die auf dem oberen Haltestreifen (12) angeordnete Lage (18) aus Haftkleber an der auf dem Abdeckstreifen (52,62) angeordneten Lage (58) aus klebekraftabweisendem Material anhaftet, wobei die Bindevorrichtung (24) eine entlang des inneren Randes des Abdeckstreifens (52,62) angeordnete Einrichtung aufweist, um eine Trennung des Abdeckstreifens (52,62) und eine Schwenkung des Abdeckstreifens (52,62) relativ zu dem oberen Haltestreifen (12) um im wesentlichen parallel zu den inneren Rändern (15) verlaufende Achsen zu ermöglichen, wobei die Steifigkeit des Abdeckstreifens (52,62), der Grad an Anhaftung zwischen der auf dem oberen Haltestreifen (12) angeordneten Lage (18) aus Haftkleber und der auf dem Abdeckstreifen (52,62) angeordneten Lage (54) aus klebekraftabweisendem Material und der durch die Bindeeinrichtung (24) verursachte Widerstand gegen eine relativ zu den Haltestreifen (12) erfolgende Schwenkbewegung des Abdeckstreifens (52,62) derart gewählt sind, daß der Abdeckstreifen (52,62), indem man ihn entlang eines Randes greift, leicht manuell von der auf dem oberen Haltestreifen (12) angeordneten Lage (18) aus Haftkleber getrennt und von dem oberen Haltestreifen (12) weg geschwenkt werden kann.
9. Bindevorrichtung nach einem der Ansprüche 1 bis 8, ferner mit einer Trägerschicht (67) mit vorderen und rückwärtigen Flächen, wobei entlang der inneren Ränder (15) der Haltestreifen (12) die Bindeeinrichtung entlang der vorderen Fläche der Trägerschicht (67) befestigt ist.
10. Bindevorrichtung nach einem der Ansprüche 1 bis 9, bei der die entlang der vorderen Flächen (13,93) der Haltestreifen (12,92) angeordneten Lagen (18,98) aus Haftkleber wiederpositionierbaren Haftkleber aufweisen.
11. Bindevorrichtung nach einem der Ansprüche 1 bis 9, bei der die entlang den vorderen Flächen (13,93) der Haltestreifen (12,92) angeordneten Lagen

(18,98) aus Haftkleber lösbaren Haftkleber aufweisen.

12. Bindevorrichtung nach einem der Ansprüche 1 bis 11, bei der die entlang den vorderen Flächen (13,93) der Haltestreifen (12,92) angeordneten Lagen (18,98) aus Haftkleber Permanent-Haftkleber aufweisen.

Revendications

1. Ensemble formant reliure pour relier ensemble une pluralité de feuilles séparées, ledit ensemble formant reliure comportant:
- ♦ une pluralité de bandes supports (12, 92) dont chacune des bandes supports (12, 92) présente des surfaces principales avant et arrière (13, 14, 93, 94), des bords intérieur et extérieur opposés (15, 16, 95, 96), et des extrémités opposées (17, 97);
 - ♦ une couche (18, 98) d'adhésif sensible à la pression le long de ladite surface avant (13, 93) de ladite bande support (12, 92);
 - ♦ une couche (20, 100) de matériau à détacher sur la surface arrière (14, 94) de ladite bande support (12, 92);
 - ♦ lesdites bandes supports (12, 92) ayant adhéré ensemble pour former une pile de bandes supports (122) dont lesdits bords intérieurs (15, 95) desdites bandes supports (12, 92) sont en alignement, dont les couches (18, 98) d'adhésif sensible à la pression se trouvant sur les bandes supports (12, 92) adhèrent aux couches (20, 100) de matériau à détacher se trouvant sur les bandes supports (12, 92) adjacentes, et dont les surfaces avant (13, 93) des bandes supports (12, 92) sont placées en-dessus dans la pile (22);
 - ♦ ledit ensemble formant reliure incluant en outre des moyens de reliure (124, 104) le long desdits bords intérieurs desdites bandes supports (12, 92) pour permettre la séparation desdites bandes supports (12, 92) et le pivotement desdites bandes supports (12, 92) l'une par rapport à l'autre autour d'axes généralement parallèles auxdits bords intérieurs (15, 95);
 - ♦ la rigidité desdites bandes supports (12, 92), les caractéristiques d'adhérence de la couche (18, 98) de l'adhésif sensible à la pression, le niveau d'adhérence entre lesdites couches (18, 98) d'adhésif sensible à la pression et lesdites couches (20, 100) de matériau à détacher et la résistance au mouvement de pivotement desdites bandes supports (12, 92) l'une par rapport à l'autre provoquée par lesdites moyens de reliure (24, 104) étant choisis de façon qu'il suffise d'utiliser une force de traction, appli-

quée par l'intermédiaire d'une feuille de papier (25) adhérent sur toute la longueur de la couche (18, 98) d'adhésif sensible à la pression se trouvant sur l'une des bandes supports (12, 92), pour séparer ladite bande support (12, 92) d'avec une bande support adjacente (12, 92) adhérent à la couche (20, 100) de matériau à détacher se trouvant sur la surface de ladite bande support (12, 92) et pour provoquer le pivotement de ladite bande support (12, 92) pour l'écarter de la bande support (12, 92) dont la bande support (12, 92) s'est séparée.

2. Ensemble formant reliure selon la revendication 1, dans lequel le bord extérieur de chaque bande support (12, 92) de la pile de bandes supports (12, 92) dépasse au-delà du bord extérieur de la bande support (12, 92) immédiatement inférieure dans la pile de bandes supports (22), d'une distance valant environ 0,02 à 0,160 cm (0,008 à 0,063 pouce).
3. Ensemble formant reliure selon la revendication 1 ou 2, dans lequel lesdits moyens de reliure (24, 104) prévus le long desdits bords intérieurs (15, 95) desdites bandes supports (12, 92) pour permettre la séparation desdites bandes supports (12, 92) et le pivotement desdites bandes supports (12, 92) l'une par rapport à l'autre autour d'axes généralement parallèles auxdits bords intérieurs (15, 95) comportent, pour chaque bande support (12, 92), une bande allongée formant charnière (24) qui est significativement plus flexible autour d'un axe longitudinal que ladite bande support (12, 92), ladite bande formant charnière (26) présentant des surfaces principales opposées, un premier et un second bords opposés (29, 30), une portion de fixation (31) adjacente audit premier bord (29) adhérent le long d'une portion de ladite bande support (12, 92) près du bord intérieur (15) de ladite bande support (12, 92), une portion d'ancrage (32) adjacente audit second bord (30) et une portion centrale formant charnière entre lesdites portions de fixation et d'ancrage (31, 32), lesdites portions d'ancrage (32) étant attachées ensemble dans une pile d'ancrage (34) prévue pour être fixée sur un substrat et ladite bande formant charnière (26) pouvant, indépendamment, se cintrer autour d'axes s'étendant selon la direction longitudinale de ladite bande formant charnière (26) pour permettre le pivotement de ladite bande support (12, 92) pour l'écarter de la bande support (12, 92) dont ladite bande support (12, 92) s'est séparée.
4. Ensemble formant reliure selon l'une quelconque des revendications 1 à 3' dans lequel lesdits moyens de reliure (24) prévus le long desdits bords intérieurs (15) desdites bandes supports (12) pour permettre la séparation desdites bandes supports

(12) et le pivotement desdites bandes supports (12) l'une par rapport à l'autre autour d'axes, généralement parallèles auxdits bords intérieurs (15) comportent une couche (82) d'adhésif fondant à chaud, flexible, adhérant le long des bords intérieurs (15) desdites bandes supports (12).

5. Ensemble formant reliure selon la revendication 1, dans lequel lesdits moyens de reliure (104) prévus le long desdits bords intérieurs (95) desdites bandes supports (92) pour permettre la séparation desdites bandes supports (92) et le pivotement desdites bandes supports (92) l'une par rapport à l'autre autour d'axes, généralement parallèles auxdits bords intérieurs (95) comportent une pluralité d'ouvertures traversantes alignées (105) dans lesdites bandes supports (92) prévues pour que des anneaux espacés et disposés autour d'un axe commun y soient reçus et y coulissent.

6. Ensemble formant reliure selon l'une quelconque des revendications 1 à 3, incluant en outre sur ladite pile d'ancrage (34) des moyens (44, 46, 70) prévus pour attacher ladite pile d'ancrage (34) à un substrat.

7. Ensemble formant reliure selon l'une quelconque des revendications 1 à 3, incluant en outre, sur ladite pile d'ancrage (34) des moyens (44, 46, 70) prévus pour attacher ladite pile d'ancrage à un substrat et, sur ledit substrat, des moyens (47) prévus pour qu'y soit attachée la pile d'ancrage d'un autre desdits ensembles formant reliure.

8. Ensemble formant reliure selon l'une quelconque des revendications 1 à 7, incluant en outre une bande de couverture allongée (52, 62) présentant des surfaces principales avant et arrière (53, 54), des bords intérieur et extérieur opposés (55, 56, 63, 64), et des extrémités opposées (57, 66);

une couche de matériau à détacher (58) sur la surface arrière (54) de ladite bande de couverture (52, 62), ladite bande de couverture (52, 62) adhérant à la bande support supérieure (12) de ladite pile (22), le bord intérieur (55, 63) de ladite bande de couverture (52, 62) étant aligné avec les bords intérieurs (15) desdites bandes supports (12) et la couche (18) d'adhésif sensible à la pression se trouvant sur ladite bande support supérieure (12) adhérant à la couche (58) de matériau à détacher se trouvant sur la bande de couverture (52, 62); lesdits moyens de reliure (24) incluant, le long dudit bord intérieur de ladite bande de couverture (52, 62), des moyens pour permettre la séparation de ladite bande de couverture (52, 62) et le pivotement de ladite bande de couver-

ture (52, 62) par rapport à ladite bande support supérieure (12) autour d'axes généralement parallèles auxdits bords intérieurs (15); la rigidité de ladite bande de couverture (52, 62), le niveau d'adhérence entre la couche (18) d'adhésif sensible à la pression se trouvant sur ladite bande support supérieure (12) et ladite couche (54) de matériau à détacher se trouvant sur ladite bande de couverture (52, 62) et la résistance au mouvement de pivotement de ladite bande de couverture (52, 62) par rapport auxdites bandes supports (12) provoquée par lesdits moyens de reliure (24) étant choisis de façon que l'on puisse facilement, à la main, séparer ladite bande de couverture (52, 62) d'avec la couche (18) d'adhésif sensible à la pression se trouvant sur ladite bande support supérieure (12) et la faire pivoter pour l'écarter de la bande support supérieure (12) en saisissant la bande de couverture (52, 62) le long d'un bord.

9. Ensemble formant reliure selon l'une quelconque des revendications 1 à 8, incluant en outre un élément formant dos (67) présentant des surfaces avant et arrière, lesdits moyens de reliure prévus le long desdits bords intérieurs (15) desdites bandes supports (12) étant attachés le long de la surface avant dudit élément formant dos (67).

10. Ensemble formant reliure selon l'une quelconque des revendications 1 à 9, dans lequel lesdites couches (18, 98) d'adhésif sensible à la pression se trouvant le long desdites surfaces avant (13, 93) desdites bandes supports (12, 92) sont en adhésif sensible à la pression, repositionnable.

11. Ensemble formant reliure selon l'une quelconque des revendications 1 à 9, dans lequel lesdites couches (18, 98) d'adhésif sensible à la pression se trouvant le long desdites surfaces avant (13, 93) desdites bandes supports (12, 92) sont en adhésif sensible à la pression, amovible.

12. Ensemble formant reliure selon l'une quelconque des revendications 1 à 11, dans lequel lesdites couches (18, 98) d'adhésif sensible à la pression se trouvant le long desdites surfaces avant (13, 93) desdites bandes supports (12, 92) sont en adhésif sensible à la pression, permanent.

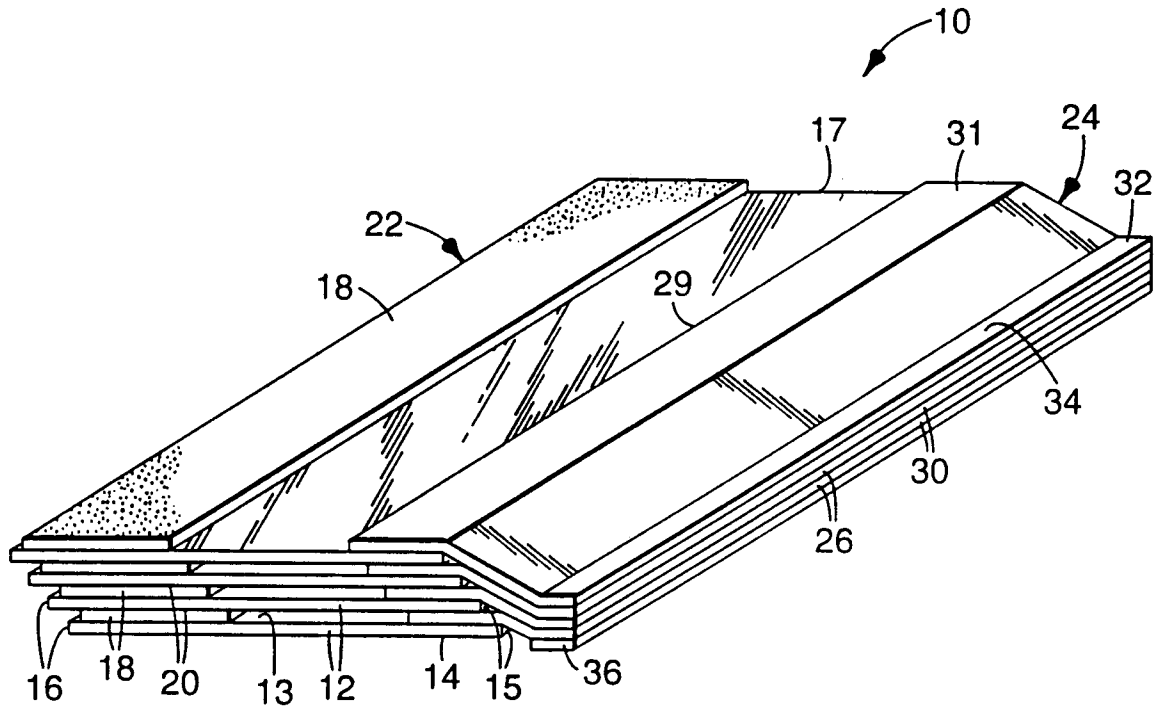

Fig. 1

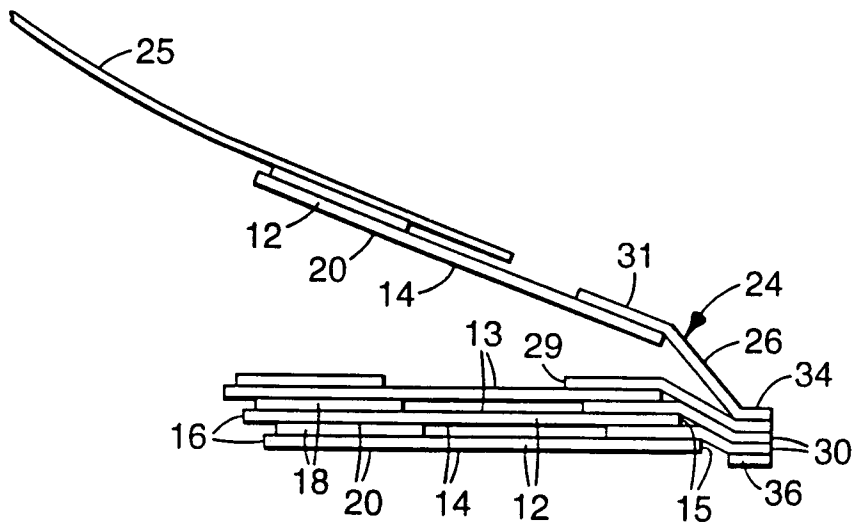

Fig. 2

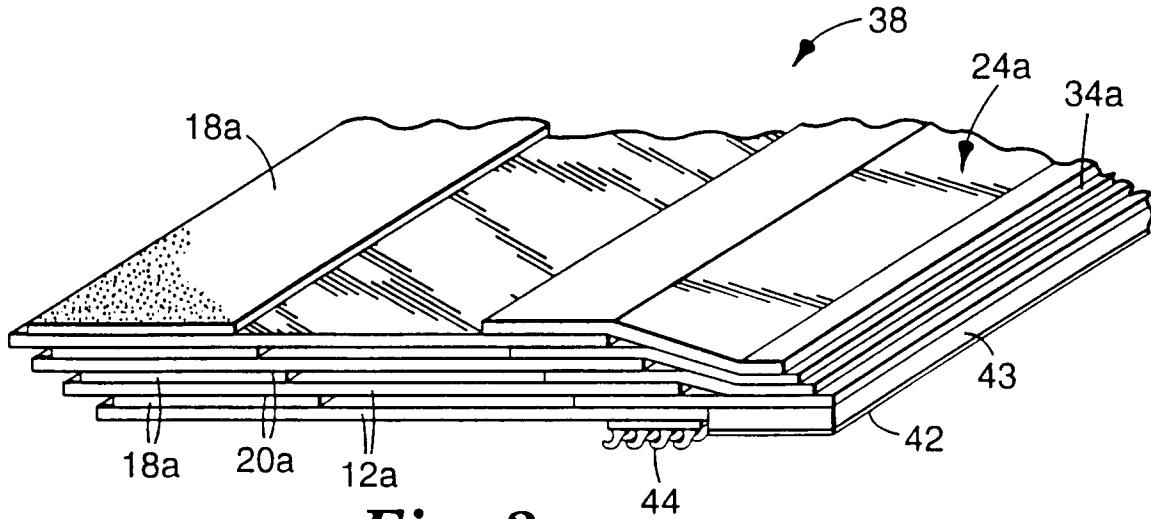

Fig. 3

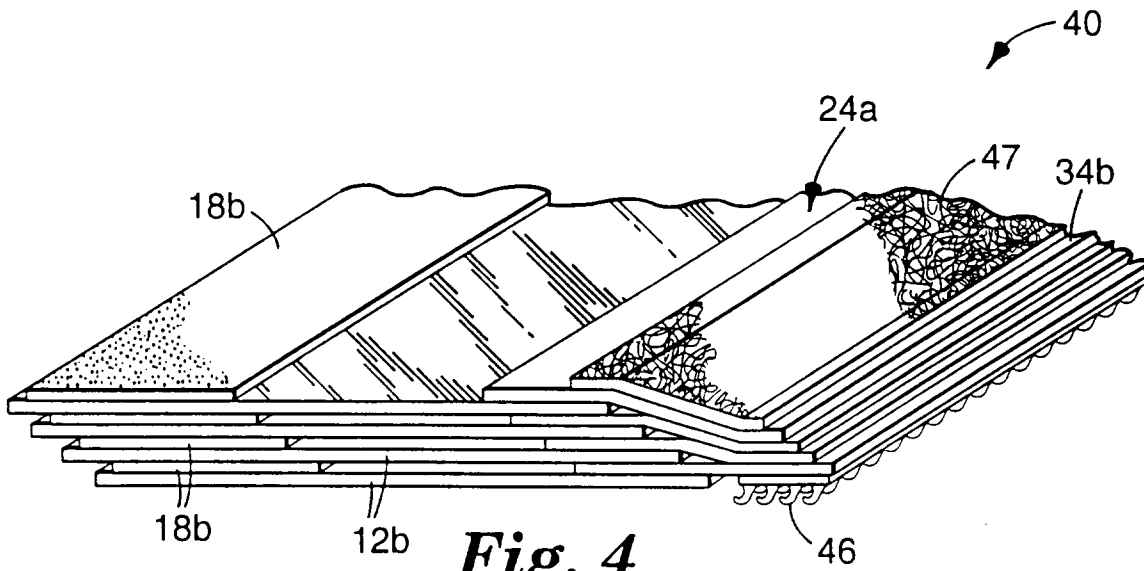

Fig. 4

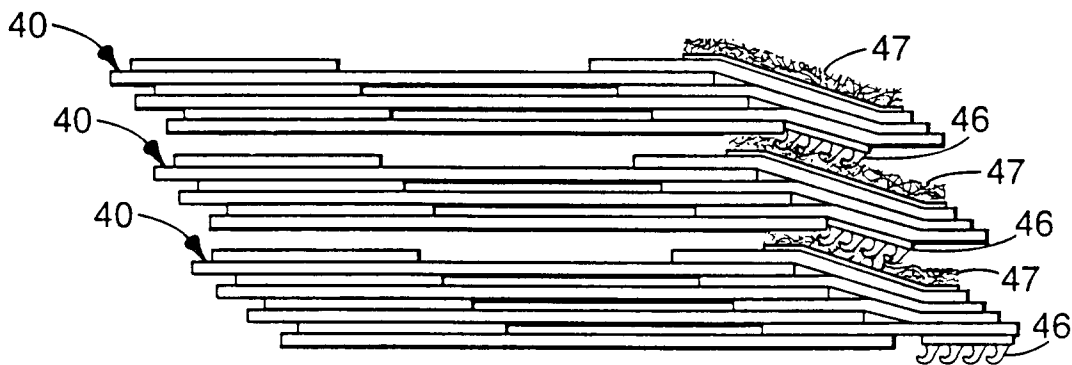

Fig. 5

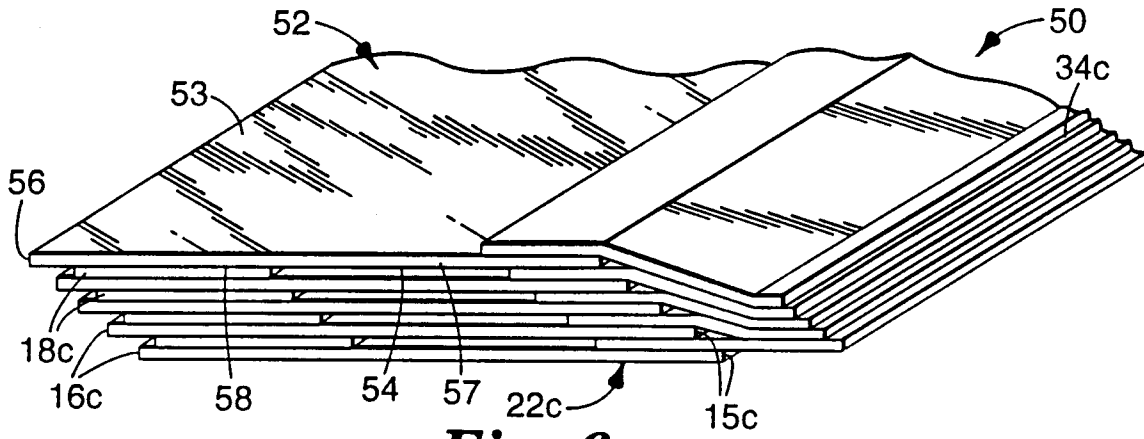

Fig. 6

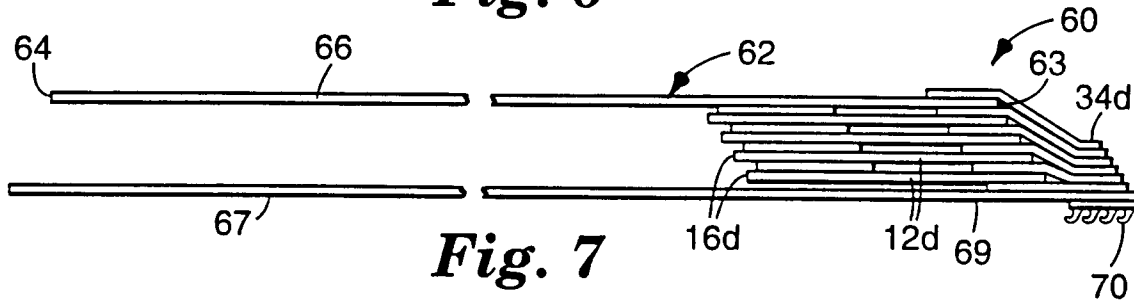

Fig. 7

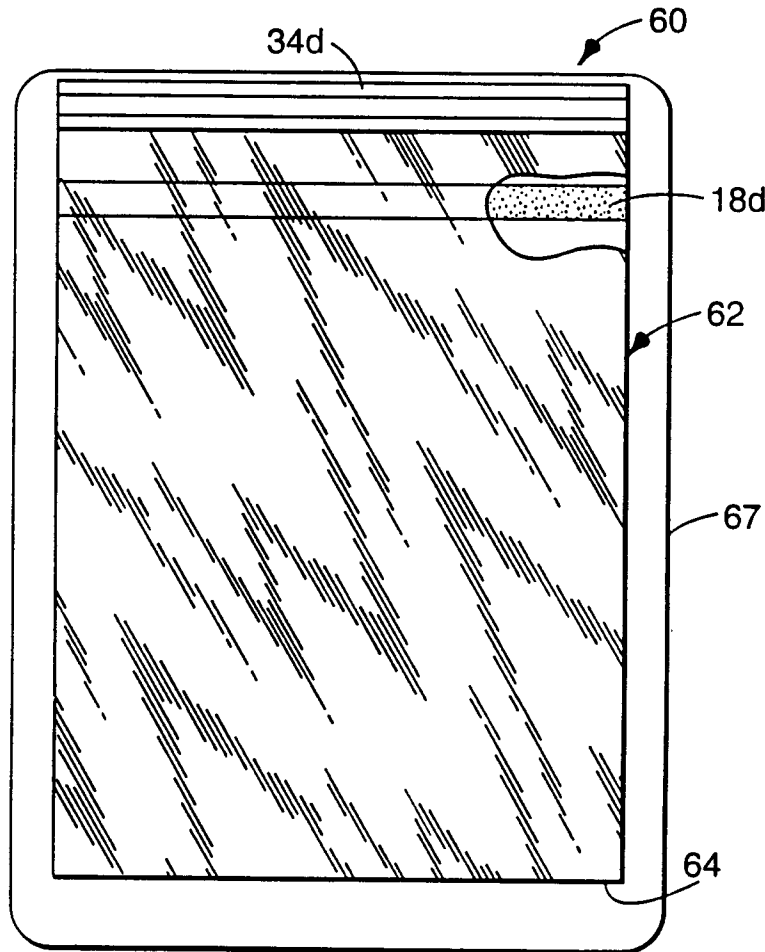

Fig. 8

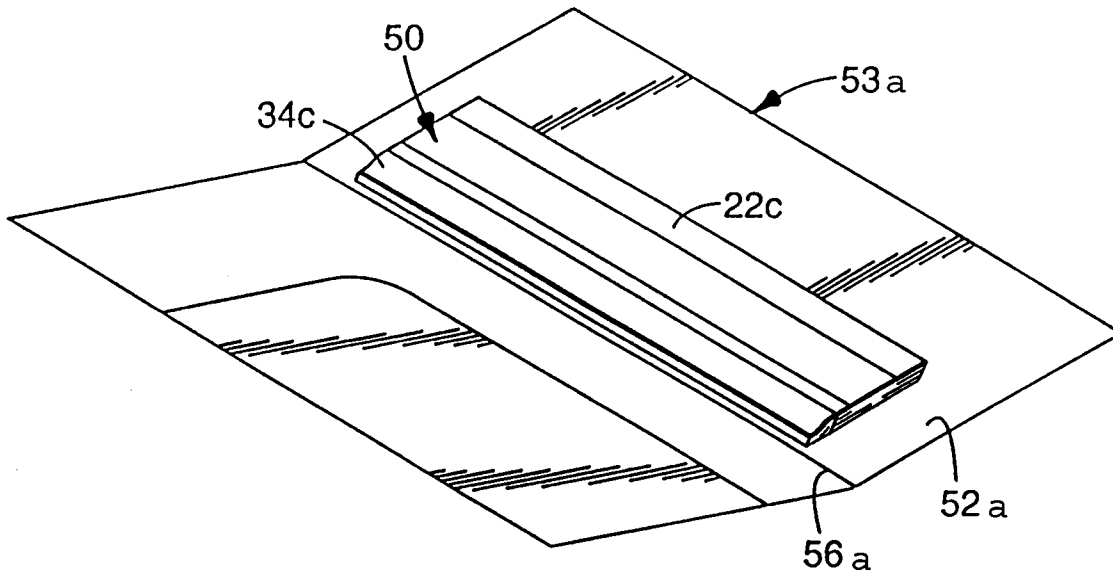

Fig. 9

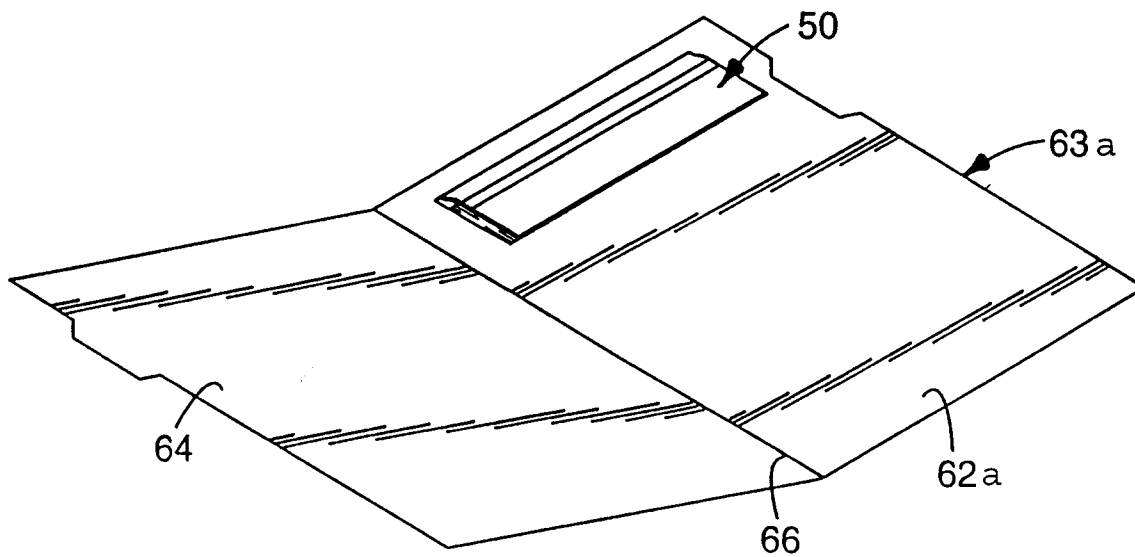

Fig. 10

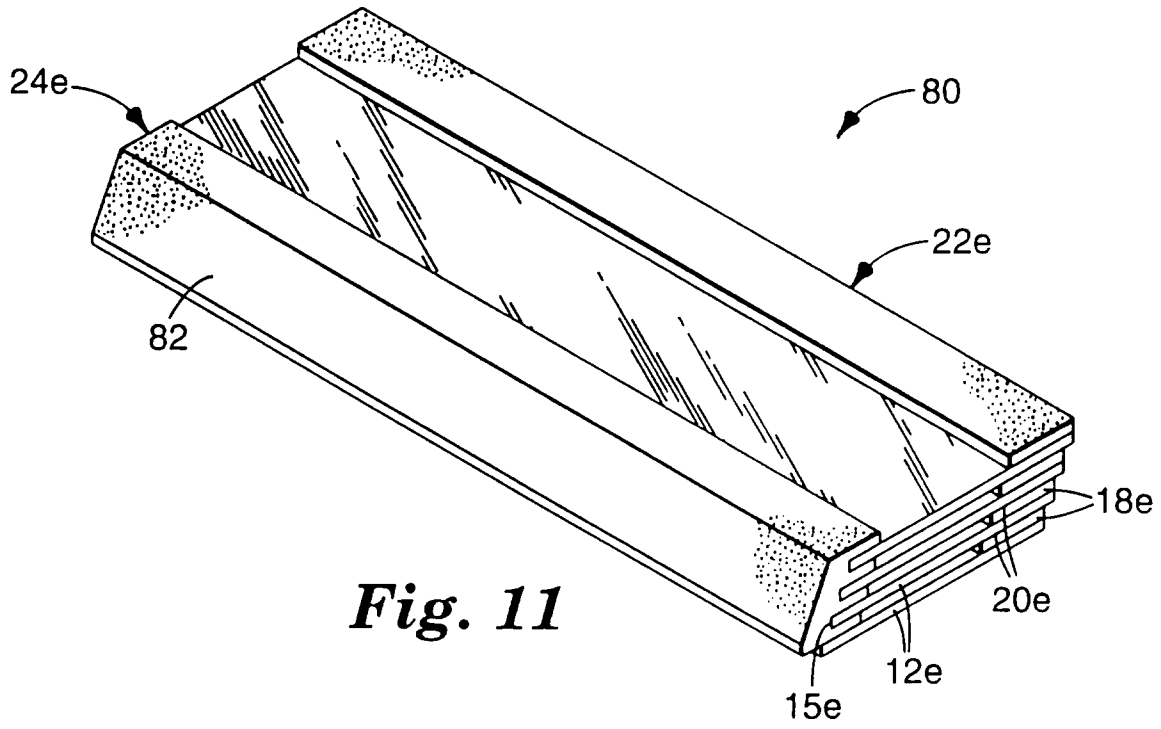

Fig. 11

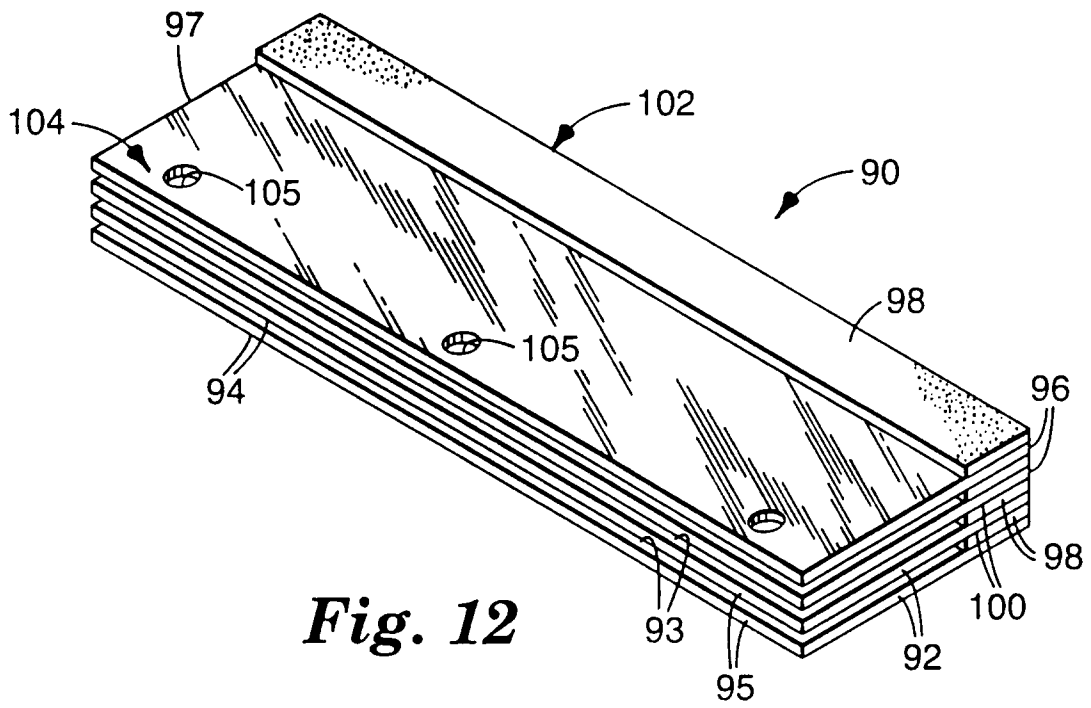

Fig. 12