



(12) **EUROPEAN PATENT APPLICATION**

(43) Date of publication:  
**09.04.1997 Bulletin 1997/15**

(51) Int Cl. 6: **E01B 9/30**

(21) Application number: **96500128.2**

(22) Date of filing: **23.09.1996**

(84) Designated Contracting States:  
**AT BE CH DE DK ES FI FR GB GR IE IT LI LU MC  
NL PT SE**

(72) Inventors:  
• **Garcia Calderon, Fernando**  
**Avda. Pio XII, s/no, 28036 Madrid (ES)**  
• **Mendoza Fernandez, José Julian**  
**Avda. Pio XII, s/no, 28036 Madrid (ES)**

(30) Priority: **22.09.1995 ES 9501841**

(71) Applicant: **RED NACIONAL DE LOS  
FERROCARRILES ESPANOLES (RENFE)**  
**28036 Madrid (ES)**

(74) Representative: **Ungria Lopez, Javier et al**  
**Avda. Ramon y Cajal, 78**  
**28043 Madrid (ES)**

(54) **Improvements introduced in elbowed plates for elastic fastenings of rails on concrete ties**

(57) This type of fastenings currently use five versions of elbowed plates, depending on whether the monoblock ties are for single rail tracks with profile UIC-54 or UIC-60, or for versatile ties for double width tracks and rails UIC-54 and UIC-60, as well as having, in these latter cases, to be assembled in the interior or exterior of the rail. On these plates about the respective cramp or elastic clip which fastens the shoe by means of the suitable screw threaded to the rail.

All these plates are lightened advantageously, forming at the bottom ten transversal webs and with the central hole (11), reinforced with a circular web (with the exception of the elbowed end guide).

All the plates have shorter preassembly supports for the clip (5), and the internal zone is circular, as well as having the notch with toroidal shape with greater size, which makes optimum the coupling of the central loop of the clip (5).

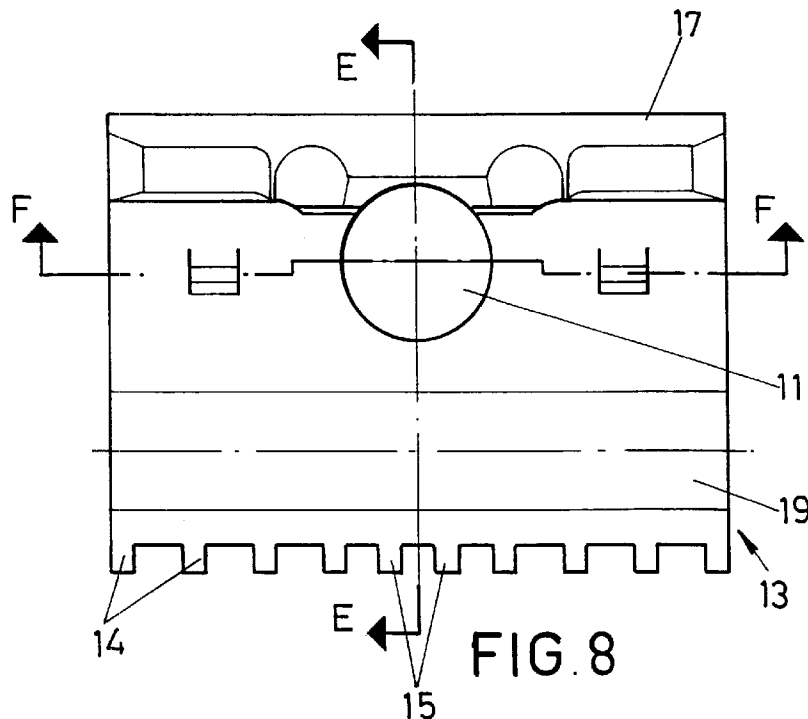

**FIG. 8**

## Description

### OBJECT OF THE INVENTION

The present invention, as expressed in the abstract of this descriptive report, refers to improvements introduced in the elbowed plates for elastic fastenings of rails on concrete ties, with which notable advantageous characteristics are offered, both for the optimization of the injection process of the constitutive plastic material, and for increasing the strength capacity of the plates versus the stresses to which they are subjected to. Likewise, the object of the invention constitutes the substantial cost reduction of each one of the parts.

The elbowed plates on which the improvements which are the object of the invention are applied, constitute the five most used versions from among those which make up the classical elastic fastenings used by RENFE (with type SkI1 clip) for the various models of concrete ties.

The parts which define the elbowed plates are placed on the rail seats, arranged to such effect on the tie, with the external and internal confronted at both sides of the rail shoe. On each one of them abuts the elastic clip, attached by means of the corresponding screw which crossed the plate to be tied down to the tie, and which achieves the correct fastening of the rail on said tie when the nominal torque is applied.

According to the invention, the improvements introduced in this type of elbowed plates are based, together with changes in the geometry of the part in order to obtain a greater seating of the clip, on the reduction of the quantity of material by means of the introduction of longitudinal webs, transversal to the shoe of the rail, which, together with a reduction in the weight, allows the obtention of greater strength against the real requirements of the parts during their running on the track.

Similarly, the replacing of the webs and consequently, the reduction of the general thicknesses of the parts, facilitates the manufacturing process, increasing the rate of the injection and making sensibly cheaper, the cost of the same, as indicated previously.

All the above expressed, is complemented with the maintenance of the housings and geometric conditions which are common to the tie, with which the optimum conditions for the operation of the parts are obtained, without distorsioning the present processes.

The ties are of prestressed monoblock concrete (prestressed or post-stressed), participating in the assembly for a single width of track, or for double width (versatile tie).

The various current types of elbowed plates are those fastening elements which transmit the vertical loads of the clip to the tie, as well as those which support the lateral thrust of the rail shoe, produced by the stress of the wheels of the trains. Therefore, its mission, besides serving as lateral buffer, is double: support of the lateral and vertical loads caused by the running of the

railroad and acting, together with the clip and the screw, as fastening element of the rail to the monoblock tie.

In the elastic fastening of the rails on the monoblock ties, the following elements participate as rail guides besides the elbowed plates:

- Seating plate: Polyethylene sheet on which the rail lies on the tie.
- Cramp or elastic clip: Steel part with suitable shape, the mission of which is to fasten the shoe of the rail onto the tie, through the seat plate.
- Screw: Steel part, with body formed by a cylindrical, partially threaded stud ended with a round head, of greater diameter than the stud, crowned by a frustum-pyramidal projection.
- Threaded spigot: Conical-frustum cylinder of plastic material, externally undulated and provided with internal thread, which is placed on the tie during its production and serves as housing of the screw.

Contributing to the fastening, the tie includes a transversal or rail seat recess which defines a housing permitting the perfect coupling of the elbowed plates and consequently that of the rest of the elements.

### BACKGROUND OF THE INVENTION

At present, the elbowed plastic plates used in the elastic fastening of rails, and which are the object of RENFE Technical Specification 03.360.566.8, form part of an elastic system, designed for the replacement of the previous metallic part, with which the monoblock ties were originally equipped with, such as is described in the standard in force (N.R.V.3-2-2-0).

The studies conducted, have made evident the possibility of modifying the design of the parts respecting its behaviour on the track, versus the stresses produced on the same, and which are summerized in vertical type compressions on its rear side, due to the torque of the clip, and lateral load stresses transmitted by the rail during the passage of the moving material.

The rail has to bear dynamic stresses during the passing of the trains, vertical ones produced by the loads transmitted by the rim of the wheels and other lateral ones, caused by the flange of the wheels when they impinge on the active face of the rail head, during the guiding of the circulation and in the correction of the detrimental movements.

The lateral stresses are produced singularly in the "opening" direction of the track, that is to say, with a tendency to separate the rails. To achieve this, they must be absorbed by the attachment system, and particularly by the elbowed part which fastens the wing of the exterior shoe to the track box, since in any other case, that is to say, if it should be displaced outwards from the rail, an excessive over-width would be produced. As a solution to this problem a system is looked for, which, by means of an increase of rigidity in the parts, makes them

more resistant to these lateral stresses.

With the object of quantifying both these stresses and the zones of the plates which are susceptible of resisting them, prior studies were conducted by finite elements (which provided the distribution of stresses on the parts for this type of loads and consequently, the areas susceptible to lightening) and in instrumentation on the track by means of extensometric gauges which permitted the quantification of the values initially predicted in the calculation by finite elements.

In the framework of these studies, a specific work programme was defined for the development of technical alternatives to this question, its culmination being the carrying out of different elbowed plates which were improved in accordance with the invention.

### **DESCRIPTION OF THE INVENTION**

In general lines, the improvements introduced in the elbowed plates for elastic fastenings of rails on concrete ties, which constitute the object of the invention, basically consist on the lightening of the parts, which vary depending on their arrangement on the ties and consequently, on their manner of work. The five most used versions of the previously indicated plates have been grouped in three blocks for this purpose:

**Interior elbowed plates** (rail versions UIC 54 and UIC 60). In these parts, the greatest design modifications are going to be made, since the mechanical demands are lesser. They basically work under vertical compression on their rear side due to the dynamic torque of the clip. Due to this situation on the internal part of the rail, the lateral load to be supported is very inferior to that exerted by the track on the exterior elbowed plates. They must also however, be equipped with a standard resistance to said requirement. The previous nomenclature answers to these standardized types of 54 or 60 kg/m rail.

**Exterior elbowed plates** (rail versions UIC 54 and UIC 60). The modification in the design of these parts is more reduced than the one carried out on its interior pairs on versatile ties, due to the fact that they must directly bear the stresses transmitted by the rail during the passage of the moving material, fundamentally, the lateral load, besides the vertical compression stress conferred by the torque of the clip on its rear side, though this be comparatively very inferior.

**Guide elbow plates.** Defined thus, are the ones used in the assembly on the concrete tie of one single width of track. With the object of maintaining a functionality criteria and to facilitate the assembly on track of these plates, a single design has been made for the two positions on the tie. Consequently, variations of the geometry have been adopted, sized to resist the loads which may be produced in the most unfavourable position, which is the exterior position.

One of the improvements introduced in this type of plates are modifications which are going to be common

to all the versions of elbowed plates, emphasizing the following:

- 5 - Preassembly supports. These overprominences of the upper side of the elbowed plate, provided for an improved adapting of the elastic clip in the preassembly position, initially of trapezoidal shape, have been shortened and their interior zone is circular.
- 10 - Support of the central loop. With the object of allowing an improved coupling of the loop configured on the central part of the elastic clip, and the part or elbowed plate, the notch having toroidal shape (which must adapt to the central loop of the clip), has been constructed wider on plan. With current non lightened parts, the radius of the central loop of the clip coincides with that of the lightening of the same, and in consequence, in practice, and due to the irregularities which are common to series manufactured parts, both elements do not always adapt at adequately. In order not to modify the present torque, the housing, in elevation continues the same.
- 15 - Hole front. The zone which supports the abutting of the central loop, on the part which surrounds the hole for the passage of the screw, has been made shorter on plan as regards current parts. This is not detrimental to the strength of the part, since the central loop of the clip, under normal operational conditions, must not transmit any load to its support. If any vertical load should exist, always compression load, it must resist without any problems with the new design.
- 20 - Arrangement of the lightenings. The different lightenings carried out on the elbowed plates, are found located on its lower part, and functionally, the lightened zone confronts the thickness of the seating plate, and consequently, does not directly receive the loads transmitted by the rail shoe. As a consequence of this lower location, accumulations of water are also avoided, as well as foreign elements which might occasion derivations or fractures.
- 25 - Homogeneity of thicknesses. In order to simplify the design of the mold, the thicknesses of the lightenings have been made homogeneous with the non lightened zones, making them meet the design requirements of an injected part. However, in all the parts, non lightened zones are maintained for safety reasons (direct contact with the shoe and other parts of greater stresses).
- 30 - Transversal lightenings. In all the elbowed plates, due to the existence of such lightenings, transversally arranged webs are formed. Considering that conventional parts, some have a rectangular configured plant and others trapezoidal, such webs are perpendicular to the rail in rectangular parts, and radial in trapezoidal parts, in all cases following the direction of the lateral loads transmitted by the rail. In exterior elbowed plates and in guide elbowed
- 35
- 40
- 45
- 50
- 55

plates, thus defined previously, the zone which is going directly to support the lateral load of the rail shoe and which is to administer and transmit the concrete through the rear support, is directly confronted to the same at the maximum height possible, given the geometry of the part. In interior elbowed plates, the plate confronted to the rail shoe is of shorter height to allow a greater lightening given the lesser previously indicated mechanical demands.

- Lateral chamfers. The front section of the elbowed plate which defines the buffer against the rail, has lateral chamfers on all the parts.

In order to better understand the characteristics of the invention and forming an integral part of this descriptive report, drawing sheets are enclosed, which include figures in which, with illustrative and non limitative character, the following has been represented.

### **BRIEF DESCRIPTION OF THE DRAWINGS**

Figure 1 is a longitudinal side elevational view, with sectioned quadrant, of an elastic fastening of rails on concrete ties, by means of conventional elbowed plates. It also corresponds to the section on the cut line A-A of figure 2.

Figure 2 is a plan view of figure 1 representation.

Figure 3 is a cross section of a conventional interior elbowed plate for rail UIC-54. It also corresponds to the section on cut line B-B of figure 4.

Figure 4 is a plan view of figure 3 representation.

Figure 5 is a section on cut line C-C of figure 4.

Figure 6 is a section on cut line D-D of figure 5.

Figure 7 is a cross section of an interior elbowed plate for rail UIC-54, according to the invention. It also corresponds to the section on cut line E-E of figure 8.

Figure 8 is a plan view of figure 7 representation.

Figure 9 is a section on cut line F-F of figure 8.

Figure 10 is a section on cut line G-G of figure 9.

Figure 11 is a lower plan view of figure 7 representation.

Figure 12 is a similar view to figure 3 of a conventional interior elbowed plate for rail UIC-60.

Figure 13 is a similar view to figure 7, but of an interior elbowed plate for rail UIC-60, according to the invention.

Figure 14 is a cross section of a conventional exterior elbowed plate for rail UIC-54. It also corresponds to the section on cut line H-H of figure 15.

Figure 15 is a plan view of figure 14 representation.

Figure 16 is a section on cut line I-I of figure 15.

Figure 17 is a section on cut line J-J of figure 16.

Figure 18 is a cross section of an exterior elbowed plate for rail UIC-54, according to the invention. It also corresponds to the section on cut line K-K of figure 19.

Figure 19 is a plan view of figure 18 representation.

Figure 20 is a section on cut line L-L of figure 19.

Figure 21 is a section on cut line M-M of figure 20.

Figure 22 is a lower plan view of figure 18 representation.

Figure 23 is a similar view to figure 14 but of a conventional exterior elbowed plate for rail UIC- 60.

Figure 24 is a similar view to figure 18 but of an exterior elbowed plate for rail UIC-60 according to the invention.

Figure 25 is a cross section of a conventional elbowed guide plate for single width track. It corresponds to the section on cut line N-N of figure 26.

Figure 26 is a plan view of figure 25 representation.

Figure 27 is a section on cut line O-O of figure 26.

Figure 28 is a section on cut line P-P of figure 27.

Figure 29 is a cross section of an elbowed plate used for single widths track, including the improvements which are the object of the invention. It corresponds to the section on cut line Q-Q of figure 30.

Figure 30 is a plan view of figure 29 representation.

Figure 31 is a section on cut line R-R of figure 30.

Figure 32 is a section on cut line S-S of figure 31.

Figure 33 is a lower plan view of figure 29 representation.

Figures 34 through 38 are respective, similar views to figures 29 through 33 respectively, which represent the geometric configuration of an elbowed plate used for a single width track, according to a design achieved after having overcome a further investigation phase with prototypes, in a modified embodiment of the invention.

### **DESCRIPTION OF A PREFERRED EMBODIMENT**

With reference to the numbers adopted in the figures, and especially in relation to figures 1 and 2, it can be observed that this type of elastic fastening of rail 1 on the monoblock tie 2, is carried out by means of conventional elbowed plates 3 which are placed on one side and another of shoe 4 of rail 1. Those which are situated on the exterior part of the track are the ones which have been denominated as exterior elbowed plates, and the ones which are in the interior of the track, the interior ones. Reference 5 designates the clamp or elastic clip, materialized by the steel part which directly fastens the shoe 4 of the rail 1, after the torque of screw 6.

Reference 7 designates the seating plate on which rail 1 on tie 2 directly lies. Screw 6 remains duly tied down to tie 2, when the same includes threaded spigots 8. On their part, the elbowed plates 3 are equipped with an inferior projection 9 which meshes in housing 10 provided in tie 2.

Consequently, the elbowed plates which have been referenced with number 3, offer the conventional design of eminently solid elbowed plates, which have been modified in the manner which shall be subsequently seen in order to achieve the improvements recommended according to the invention.

Figures 3 through 6 represent one of the versions of conventional elbowed plates, specifically, the one in-

tended to remain situated in the interior part of rail UIC-54 for versatile tie (double width track). Figures 7 and 11 show the improvements introduced in this version of plates, according to the invention, with the existence of a parallel correspondence with the different views and sections of one and the other of the elbowed plates, with the exception, that in the elbowed plate which includes the improvements which are the object of the invention, the inferior plan view has been added in order to observe the arrangement of the transversal webs according to figure 11.

Analyzing comparatively both groups of figures 3 through 6 and 7 through 11, it can be observed that a general lightening has been carried out in the formers, which consists of the formation of eight complete transversal webs, 4 mm thick, laterally arranged, and another two webs of 4,5 mm interrupted by the central hole 11 for passage of screw 6. The conventional plate is referenced generally with number 12 and the one which includes the improvements which are the object of the invention, is to be found referenced with number 13.

The complete lateral webs are referenced with number 14 and the central interrupted ones with number 15.

The central hole 11, in turn, is reinforced with a circular web, also 4 mm thick, with the exception of the buffer zone against shoe 4, in which, in order to keep the 2 mm resinking provided for the preassembly of the seating plate 7, said web has to be of 3 mm in this embodiment example shown in the figures. This circular web is referenced with number 16.

The thickness of plate 13 in the zone directly confronting the rail shoe is also of 4 mm, as well as the webs 14, keeping constant in the rear section of the part. With this arrangement, the transversal webs 14 and 15 may directly receive some lateral load, less than in the exterior parts, on its upper 2 mm as shall be subsequently seen.

Buffer 17, or front and rethickened part of the elbowed plate 13, has a width of 15,4 mm in this version for rail UIC-54 and is provided with a 60° chamfer 18. Circular web 16 reinforces the central hole 11 and maintains a continuity in the transmission of stresses from the four central webs 15 and 14.

The rear support zone of the elastic clip 5, referenced with number 19 is the lightest, since the maximum thickness of 21 mm of the solid part 12, is avoided. It is considered that this lightening perfectly supports the vertical load, between 500 and 750 kg at each support point of the elastic clip 5, produced by the torque of the same.

Subsequently comparing figures 12 and 13 which respectively represent in cross section the conventional interior elbowed plate for rail UIC-60, and the same, after being modified according to the improvements of the invention, it can be said that these plates which are referenced in the same order with numbers 20 and 21, only differ from the former 12 and 13, in the width of heel 17

which passes from having 15,4 mm to 12 mm, having being said heel, referenced in this case with number 17'. Therefore, buffer 17' in the part for rail UIC-60, has a width which is compatible with the one adopted in the version for rail UIC-54, keeping the common angle of 60° of chamfer 18, allowing the production of both versions 13 and 21 with the same mold by means of added modifications.

This design allows the possibility of introducing overwidths in the track by means of the added modification. Thus, the basic size of buffer 17 may be increased in the parts for rail UIC-54, which is 12,4 mm, up to 2,5 mm or 5 mm, to permit a stepped aperture of track jointly with the exterior part (which shall be mentioned further on), every 2,5 mm, until 10 m have been reached. Similarly, part 21 for rail UIC-60 admits an increase of 2,5 mm in its basic size, 9 mm, to permit a stepped aperture of track jointly with the exterior part, every 2,5 mm up to 5 mm.

The geometry of another of the current versions of plates, specifically the one denominated as exterior elbowed plate for versatile tie with UIC-54, may be observed in detail in figures 14 through 17. This conventional exterior elbowed plate, is referenced in general with number 22. Its main difference as regards the interior elbowed plate is its trapezoidal configuration, as can be seen in figure 15.

The modifications conducted in this exterior elbowed plate 22, to achieve the recommended characteristics, according to the invention, can be observed in figures 18 through 22, the different views and sections also being shown in parallel. The new, lightened exterior elbowed plate is referenced with number 23 in these figures 18 through 22.

Since these plates 23 are elbowed in trapezoidal shape, the arrangement of the six webs is radial, whilst that of the four central webs is perpendicular to shoe 4. The oblique webs are referenced with number 24 and the transversal ones to the plate, with number 25. In this form of embodiment shown, the webs have a constant thickness of 6 mm, with the exception of the two end ones, which due to geometric reasons, is of 5,5 mm. Consequently, the thickness of the gaps is variable.

The thickness of the plate confronted directly to the rail shoe is also 6 mm, as are the webs. With this arrangement, the transversal webs do not directly receive the lateral load, although they indirectly collaborate in the transmission of stresses.

The circular web, on the contrary to the interior plates 13, reinforces the central hole 11 in its front zone, transmitting the stresses through the webs which border the same.

The correct operation of this part under lateral load, must prevent that bending stresses are transmitted to screw 6. Therefore, the rear zone directly confronted to hole 11 remains considerably lightened in these parts 23.

The rear support zone of the elastic clip 5 is light-

ened in order to overcome the present strong thicknesses, being designed with a constant thickness. However, zone 26, where this support begins, has a greater thickness than in the interior ones, in order to resist the greater alternative compression and tensile stresses which are produced in this zone when the trains pass. Also, in order to unify thicknesses, the rear support part in the tie has been lightened by 3,5 mm.

With the object of allowing the manufacturing of the two versions of exterior elbowed plates in existence, with one of them, the latter commented on for rail UIC-54, referenced with 23, and the one which is to be used for the other type of rail UIC-60, with the same mold by means of added modifications, it has been predicted that, in the same manner as for the interior parts, they shall only be differentiated in the width of the buffer. In figure 23, we can observe the cross section of this conventional exterior elbowed plate 27, and in figure 24, the cross section corresponding to the lightened plate in compliance with the invention, referenced with number 28. Buffer 29' on the part for rail UIC-60, has a width of 12 mm, which is compatible with the 18,6 mm width in the version for rail UIC-54 (see figure 18). These plates 23 and 28 having additionally, the same 60° angle of chamfer 18 of heel 29 and 29'.

This design also admits the possibility of introducing overwidths in the track by means of added modifications. Thus, the basic size of buffer 29 in parts 23 for rail UIC-54 can be reduced, from 15,6 mm to 2,5 or 5 mm, to allow a stepped aperture of track jointly with the interior part, every 2,5 mm, until the 10 mm has been reached. Similarly, part 28 for rail UIC-60 admits a 2,5 mm reduction in its basic size, 9 mm, to permit a stepped aperture of track jointly with the interior part, every 2,5 mm up to the 5 mm.

Finally, comparing the elbowed plates of figures 25 through 28, as regards the ones corresponding to figures 29 through 33, in which the conventional plastic guide elbowed plate for the single rail, is respectively represented, and including the improvements of the invention, it can be observed that they have the same design as regards the case of their arrangement, both in the interior housing as in the exterior one. In consequence, for half of the cases, it is oversized. The conventional plate is referenced in general with number 30 and in the second one with number 31.

The guide elbowed plated 31 has a rectangular contour and is distinguished at first sight from the upper part by a cylindrical mark 32 of 3 mm depth and 10 mm width, which is situated in buffer 33, centered with the hole 11.

In the same manner as for the exterior part, it has a resistant zone 6 mm thick, the same as eight of the ten transversal webs 34 and 35 (the two ends are 5,5 mm thick due to reasons of geometry), of which the eight end ones are continuous and the two central ones discontinuous. For the same reason as the exterior part, the rear part, confronted to hole 11, has been lightened.

Zone 26, where the rear support of clip 5 commences,

has a greater thickness in order to resist the superior, alternative, compression and tensile stresses which, when the trains pass, are produced in this area. Similarly, in order to unify the thickness, the rear support part on the tie has been lightened 3 mm.

This design admits the possibility of introducing overwidths in the track by means of added modifications. Thus, the basic size of the buffer, 12 mm, may be reduced or incremented into 2,5 or 5 mm, to permit a stepped aperture of track every 2,5 mm up to 10 mm.

The main advantages derived from the special optimized design of the elbowed plates, modified according to the invention, are included in three main aspects:

- 15 - **Manufacturing process.** The modifications introduced in the design of the plates permit the optimization of the injection process of the plastic material by means of the reduction of part thicknesses and the maintenance of their uniformity.

Likewise, the injection rate is notably increased, which produces an increase in the production and the productive capacity.

- 25 - **Behaviour of the plates.** All the process, described up to now, permits an increase in the strength capacity of the plates versus common stresses during the running of a railway.

The appearance of longitudinal webs in the lateral thrust direction of the rail, will increase the strength of the part versus this type of stresses

The reinforcement and redesign of the support zones of the elastic clip, confer the same with an improved seating on the plates, which influences the greater strength of the latter versus the tensile and compression loads transmitted by said clip.

- 40 - **Cost of the plates.** The substantial reduction of the cost of each one of the optimized parts, is given, on the one hand, by the improvements introduced in the manufacturing process (a greater injection rate implies a higher production and consequently a cutting of direct costs) and on the other hand, of the decrease of the quantity of raw material which constitute the plates as a consequence of the lightnings introduced.

Considering the above, and with special reference to figures 34 to 38, it can be observed that the design characteristics of an elbowed plate for single rail, improves the behaviour and productivity:

Thus, the thickness of the webs has been reduced, passing from 6 mm to 5 mm, whilst keeping the same quantity of the same. The injection process is simplified, obtaining improved results in their mechanical service and in the productivity of the manufacturing.

Additionally, the central and rear section of the part

has been raised, compressed between the two clip supports, improving the distribution of the longitudinal load which affects this zone.

A transversal web is added at 10 mm of the rear clip supports, reinforcing the part and sensibly reducing the stresses supported by the part on the rear section.

The front section of the part has also been modified on the clip support and adjacent area, lightening the material on a non service zone.

The rear section of this part, in its housing on the tie, is also lightened as regards the oversizing of the part of figures 29 through 33.

In these figures 34 through 38, to which we are now referring to, an apostrophe has been added to the references which designate sections modified as regards figures 29 through 33.

## Claims

### 1. IMPROVEMENTS INTRODUCED IN ELBOWED PLATES FOR ELASTIC FASTENINGS OF RAILS ON CONCRETE TIES,

these plates being of plastic material and of the type which remain placed on the rail seats provided on the tie at both sides of the rail, abutting on these, the cramp or elastic clip which fastens the shoe by means of the suitable screw, the ones used on single width and rail UIC-60 or UIC-54 being different from the ones assembled on versalite ties and rails UIC-54 and UIC-60, with double width rail, characterized in that they consist of interior elbowed plates (13, 21) which are additionally lightened when eight complete transversal webs (14) and another two (15) are advantageously formed, interrupted by the central hole (11) for passage of the screw (6), the same remaining reinforced with a circular web (16) and all the webs being located on the inferior side of the plate (13, 21), distinguishing the elbowed plates (13) of rails UIC-54 from the rail UIC-60 (21), only in that the latter have smaller size in the buffer zone (17, 17') against the rail (1); the exterior elbow plates (23, 28) are similar to the respective interior ones, with the exception that, by having a trapezoidal configuration, the six end webs (24) follow a radial direction of constant thickness, and the circular reinforcement web of the central hole (11) only exists in the front zone, these plates (23, 28) also having the same difference of buffer width (29, 29'), and the rear section (26) lightened, confronted to hole (11); the elbowed plates (31) for monoblock ties in a single width for track and rail UIC-60 or UIC-54 and both the interior and the exterior are equal, having a cylindrical mark (32) on the upper section, situated on the buffer (33), centered with the hole (11), having rectangular configuration and with its ten webs (34, 35) distributed in a similar manner to the interior elbowed plates of the versatile ties, the rear section confront-

ed with the hole being lightened as well as the rear support section on the tie; having also provided that all plates (13, 21, 23, 28, 31) be equipped for an improved adaptation of the clip (5) in preassembly position, with preassembly supports, initially of trapezoidal section, shorter and its interior zone circular, as well as for an improved coupling of the central loop of the clip (5) on the plate, the toroidal shaped notch made on the same, has a greater size according to a plan projection; also shortening the zone which supports the central loop support of the clip (5) on the part which surrounds the hole (11).

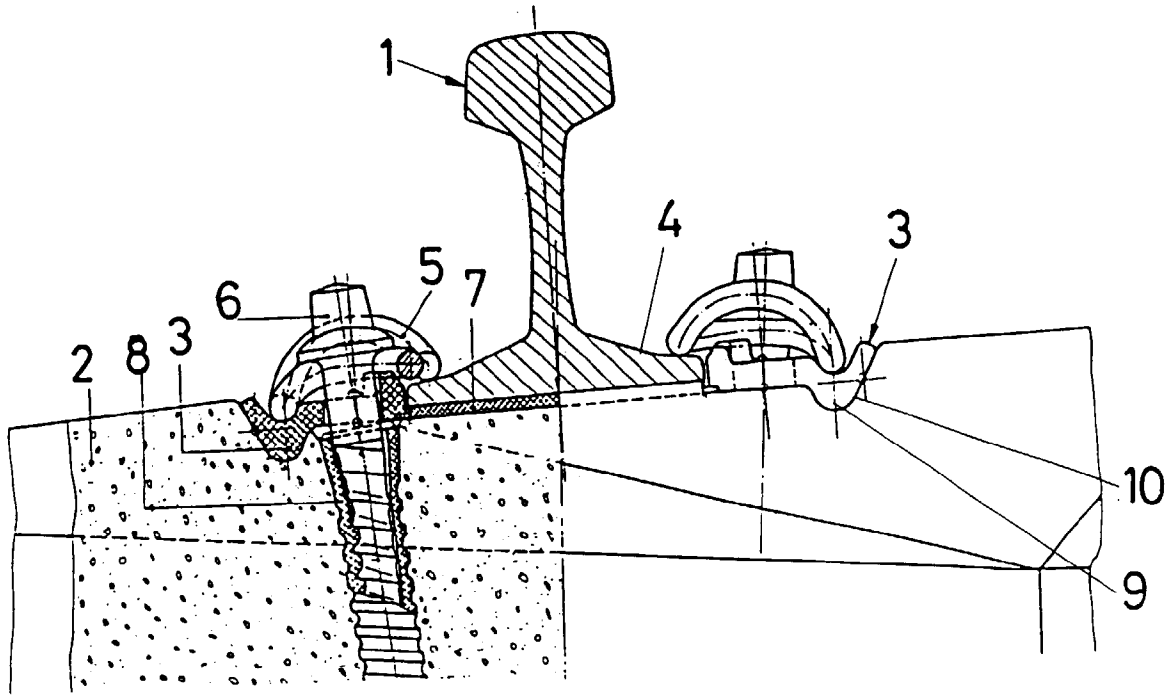

FIG. 1  
A-A

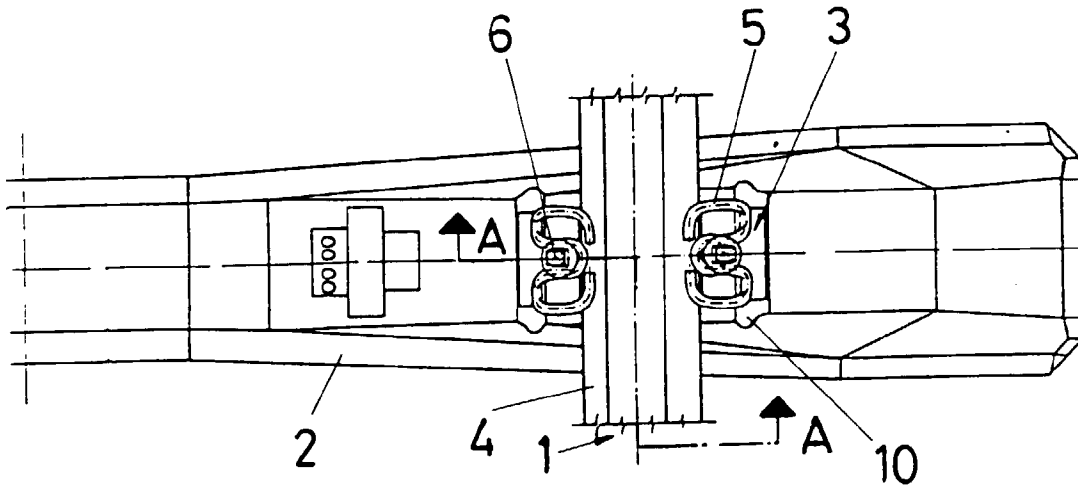

FIG. 2

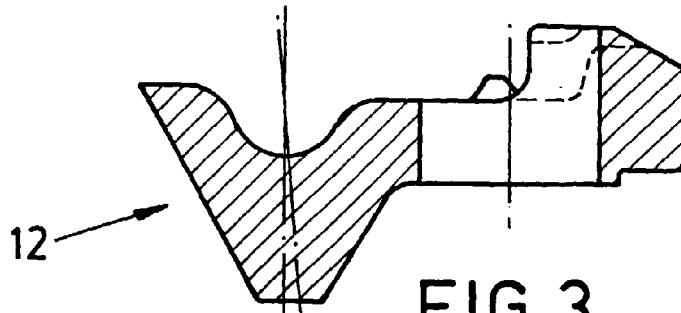

FIG. 3  
B - B

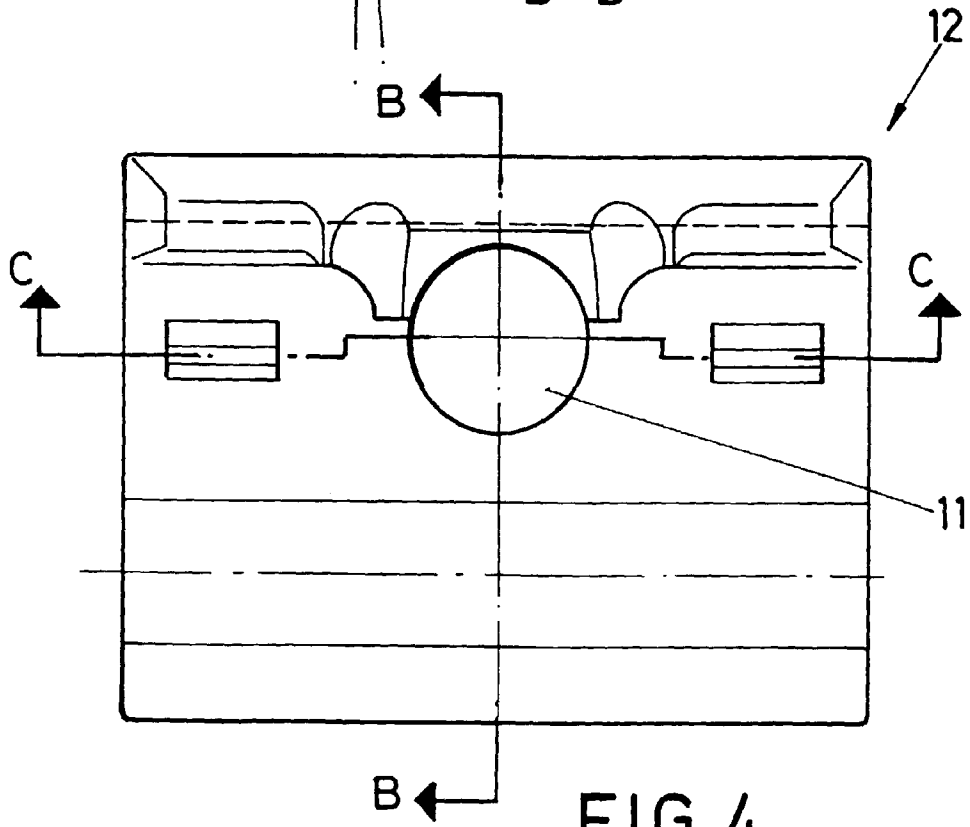

FIG. 4

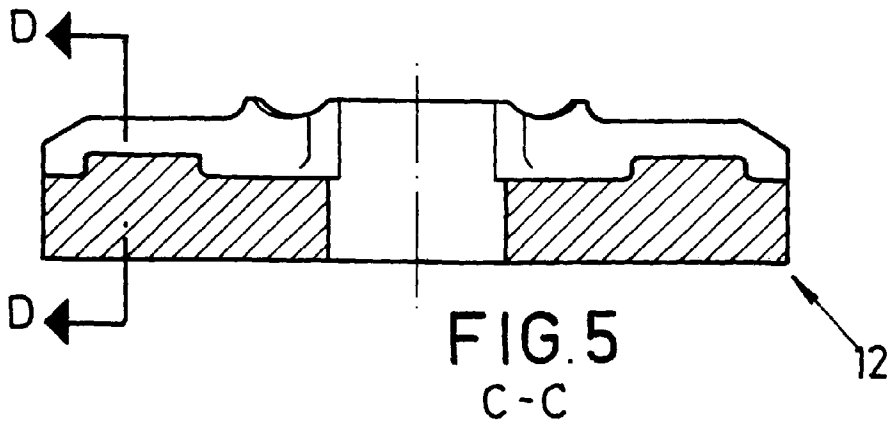

FIG. 5  
C - C

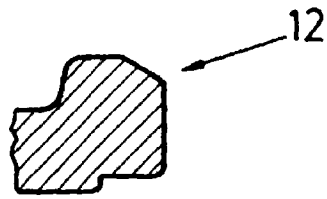

FIG. 6  
D-D

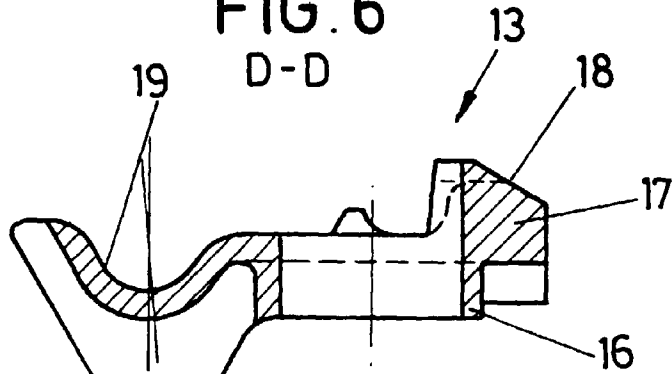

FIG. 7  
E-E

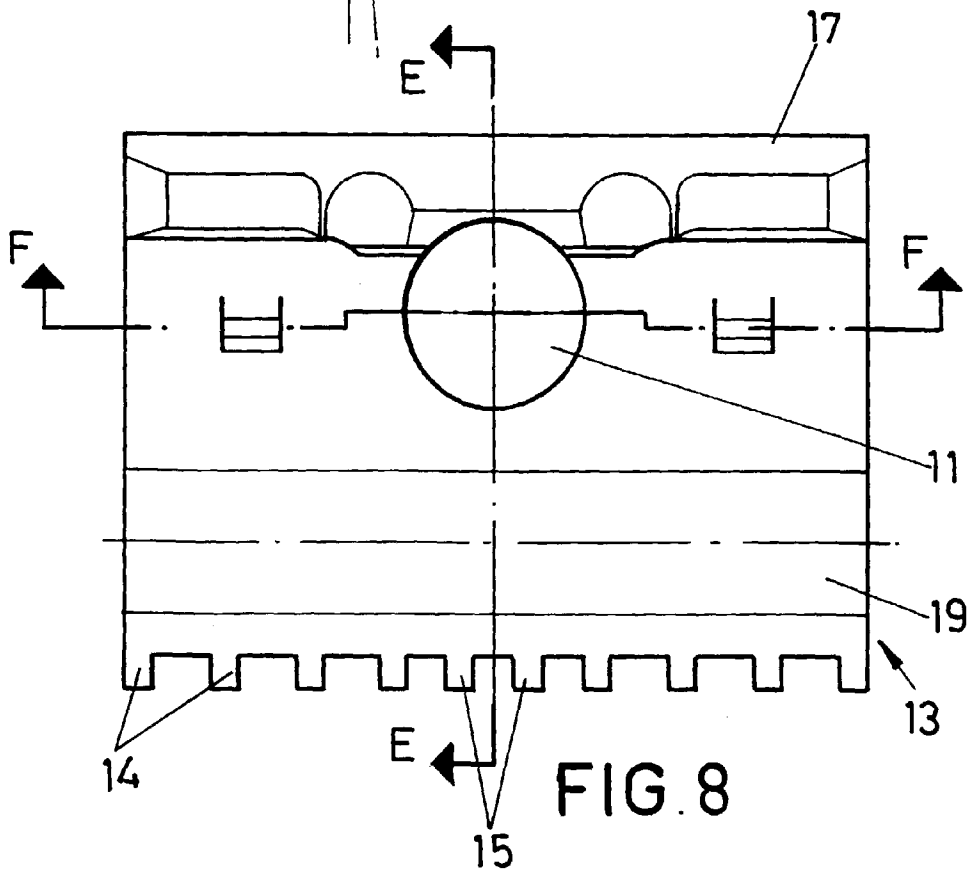

FIG. 8

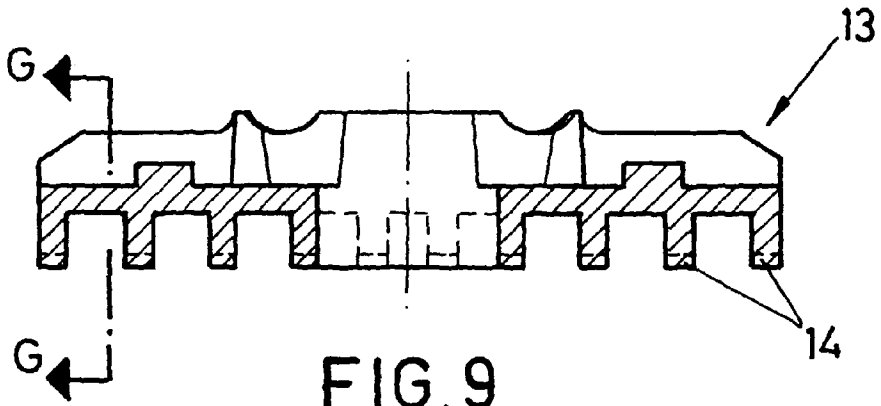

FIG. 9

F-F

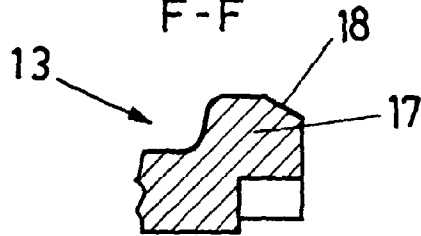

FIG. 10

G-G

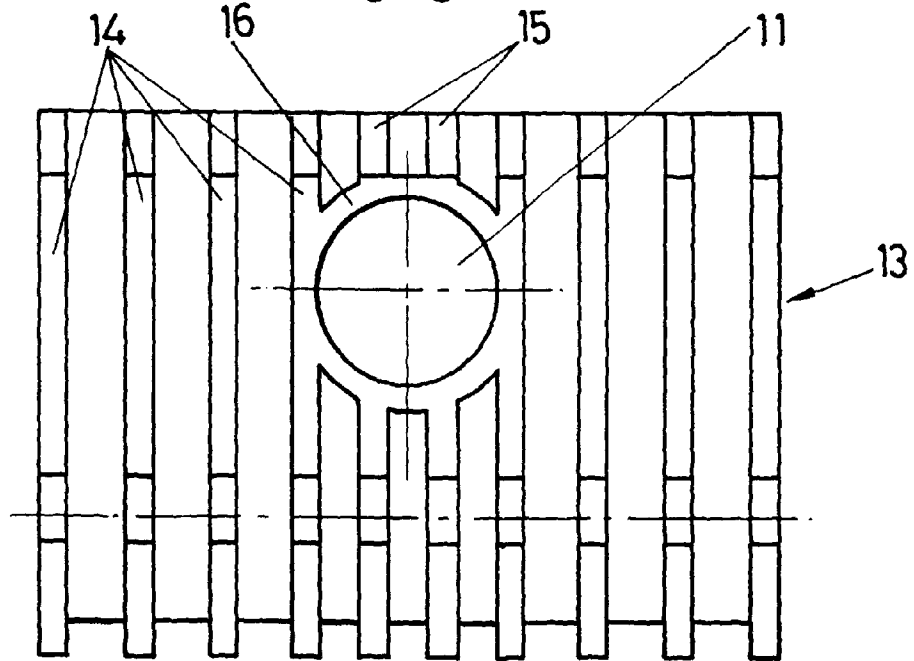
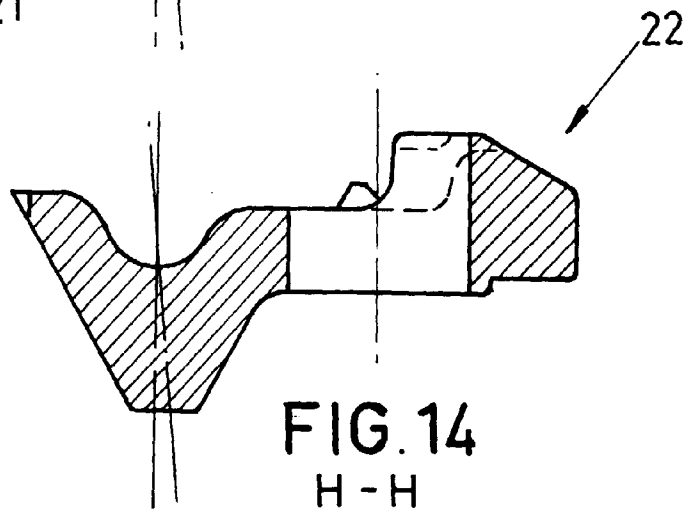
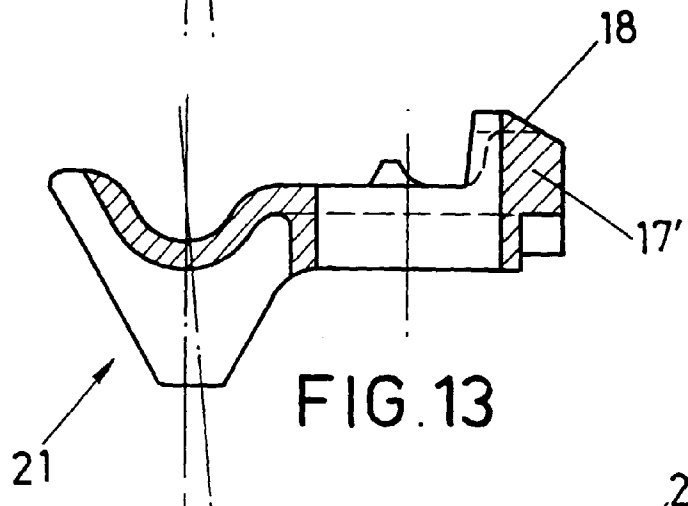
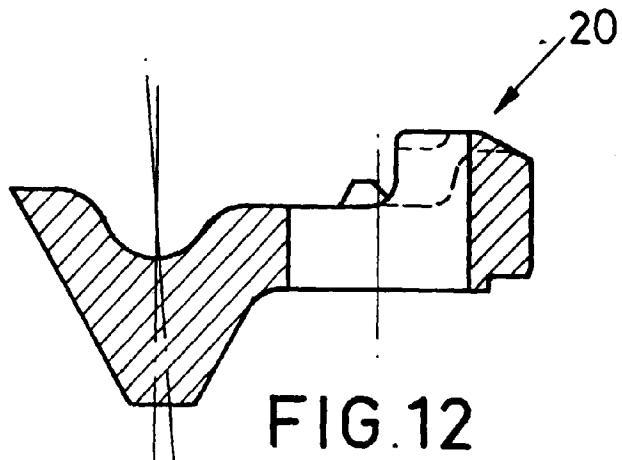

FIG. 11



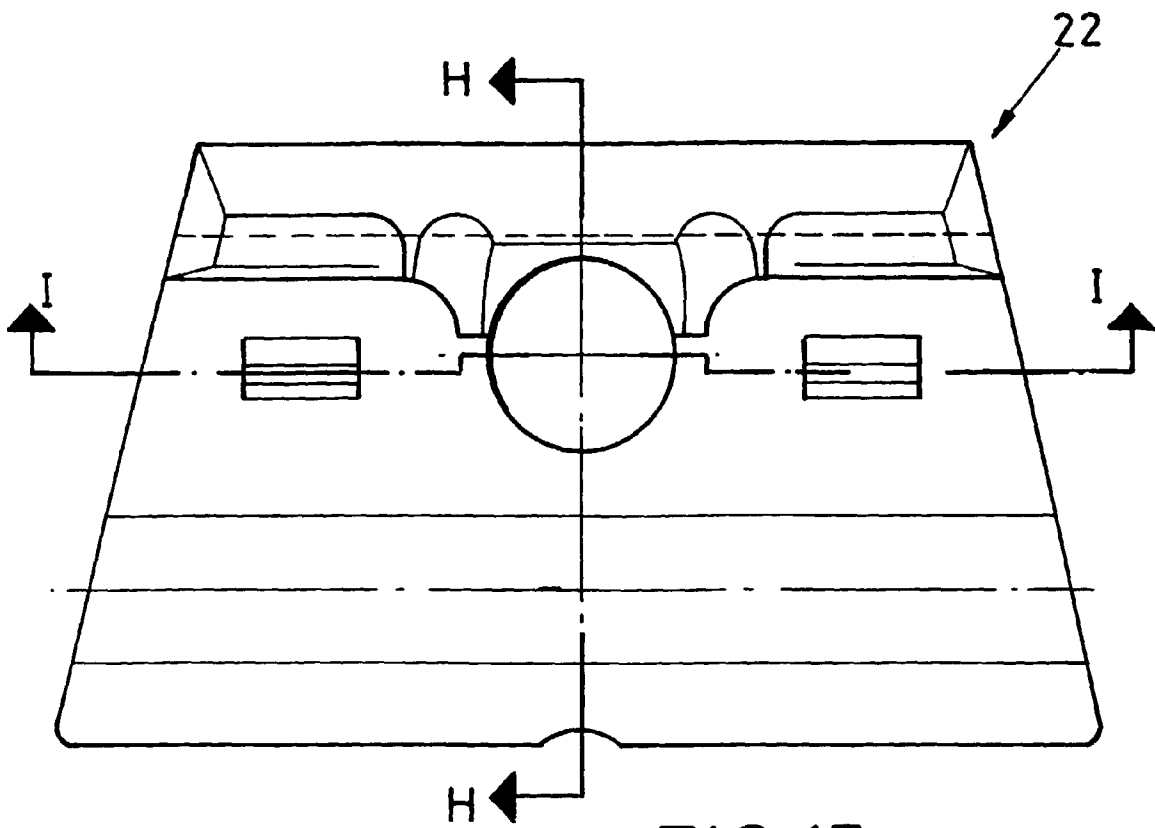

FIG. 15

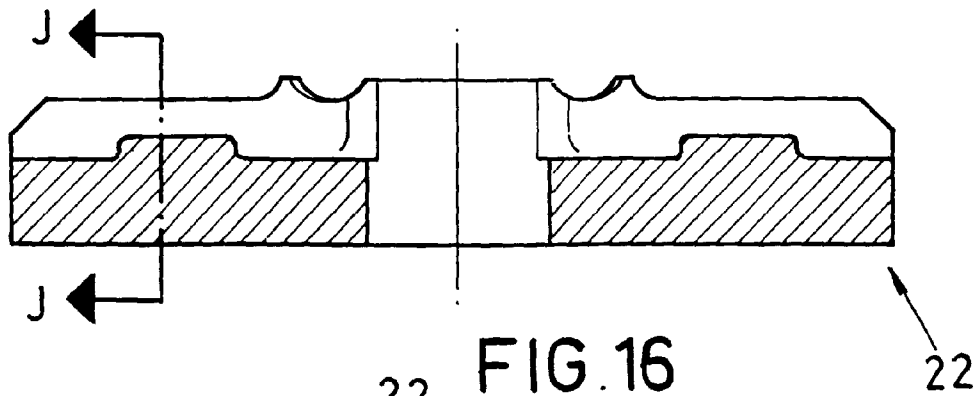

FIG. 16  
I-I

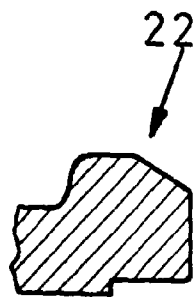
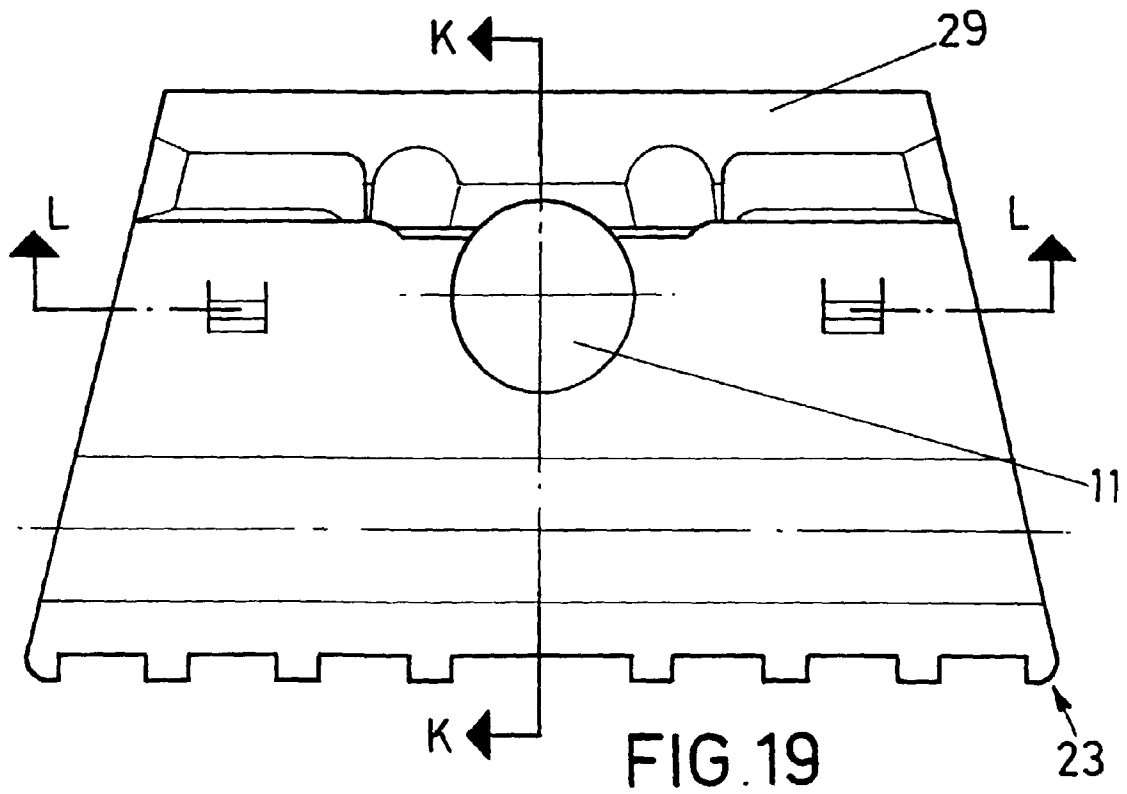
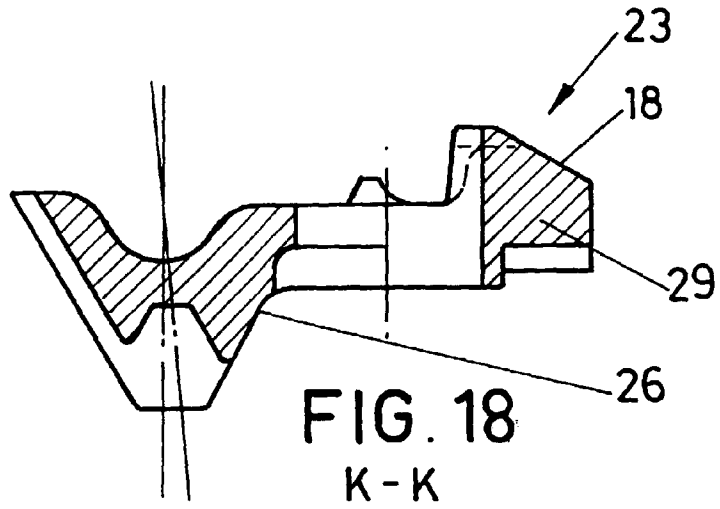

FIG. 17  
J-J



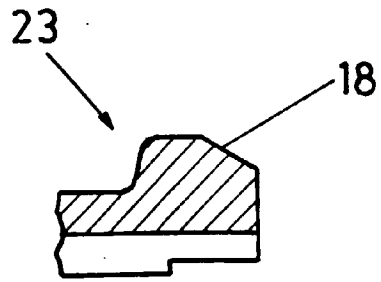

FIG. 21

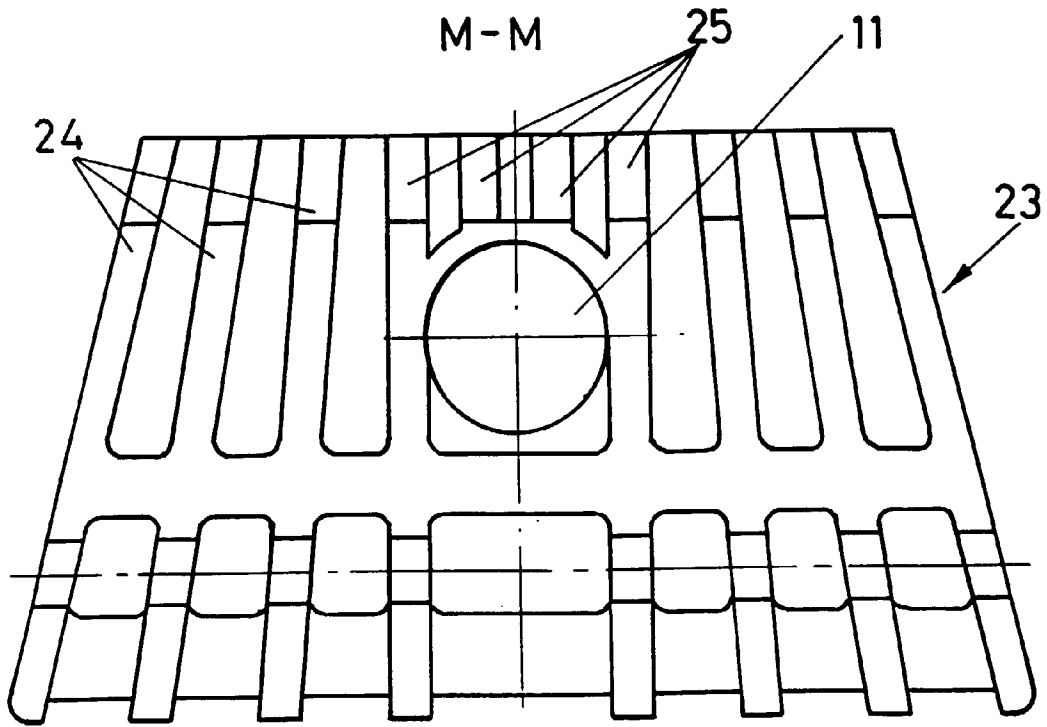

FIG. 22

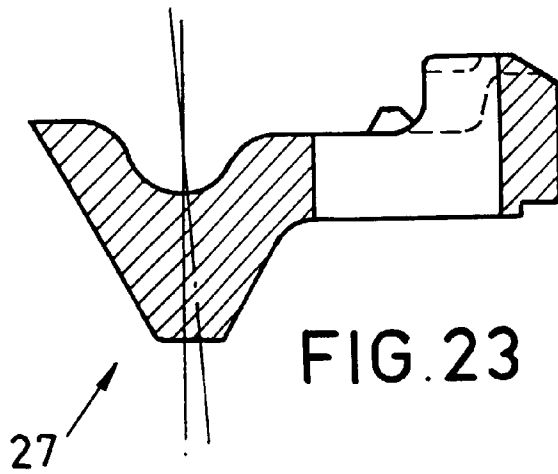
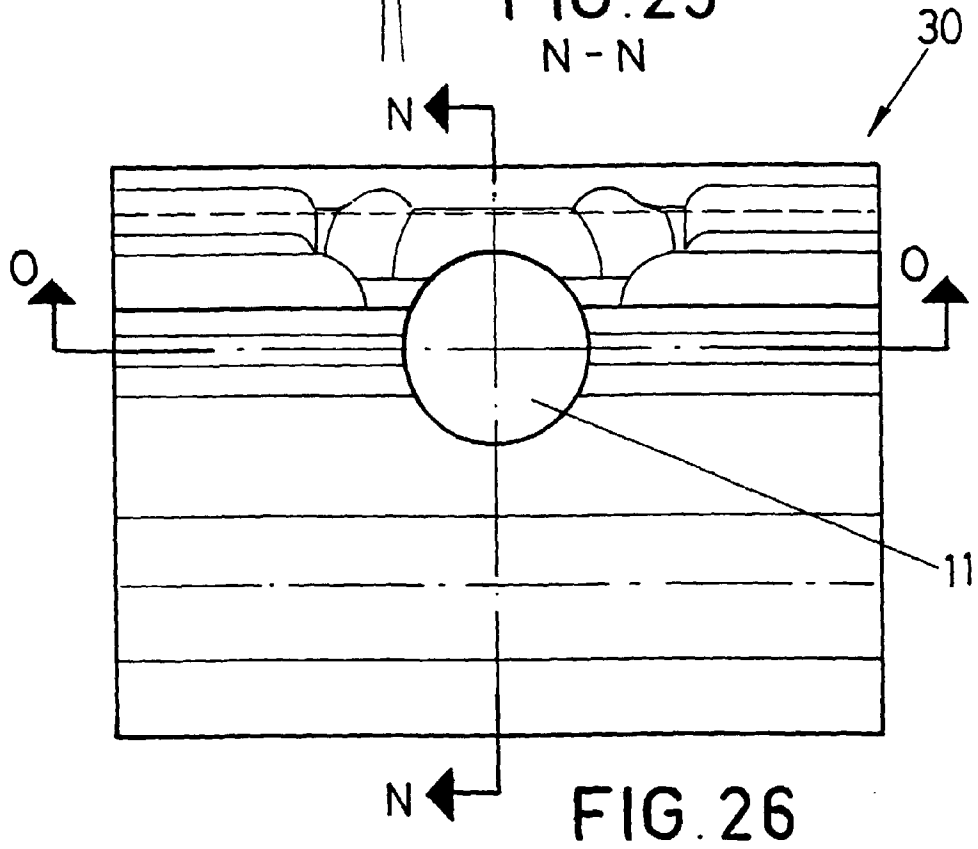
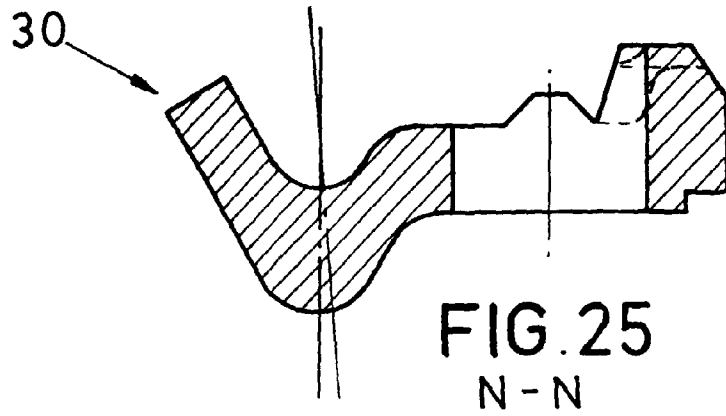
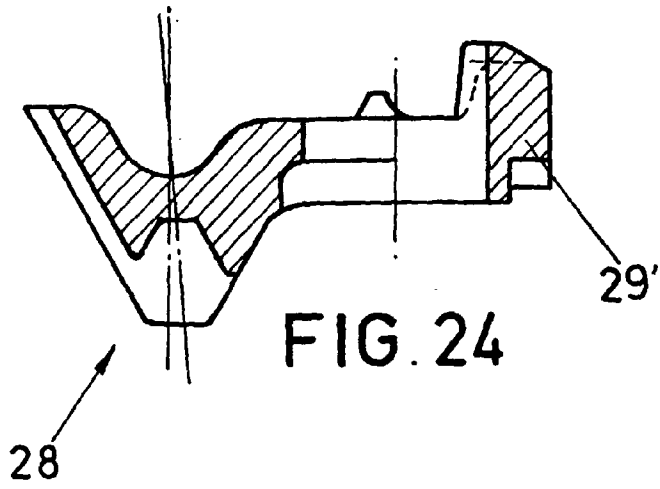

FIG. 23



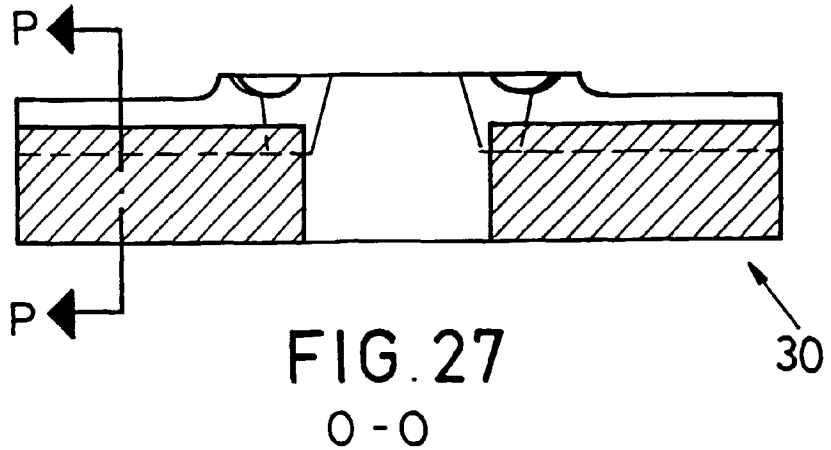

FIG. 27  
0 - 0

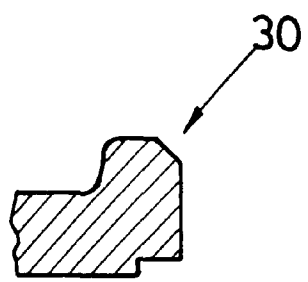

FIG. 28  
P - P

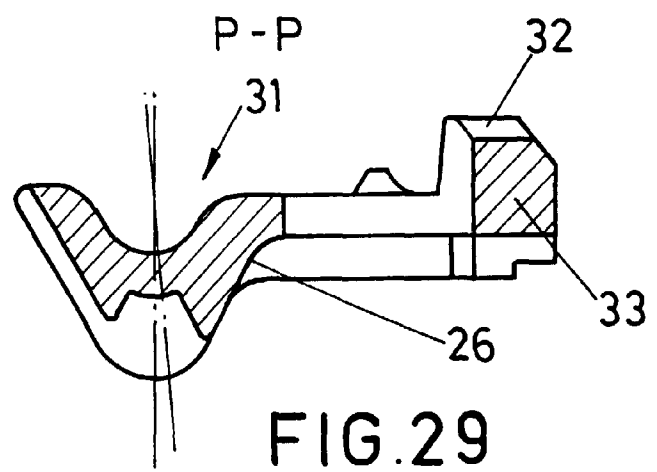
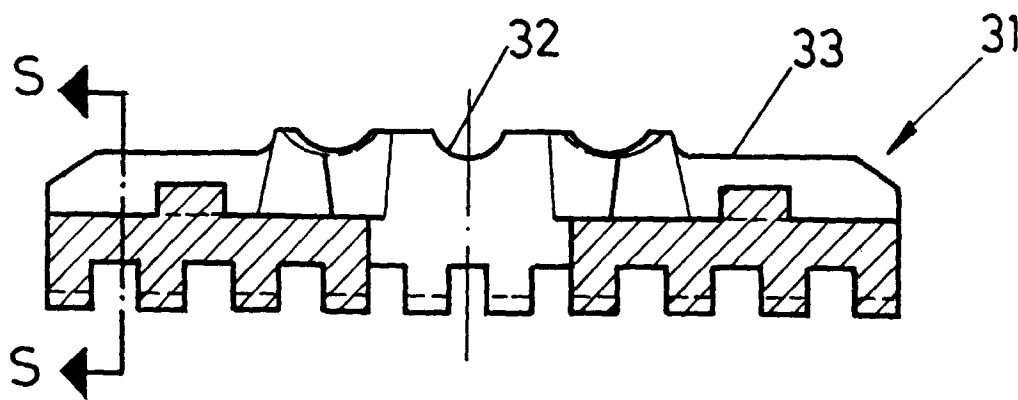
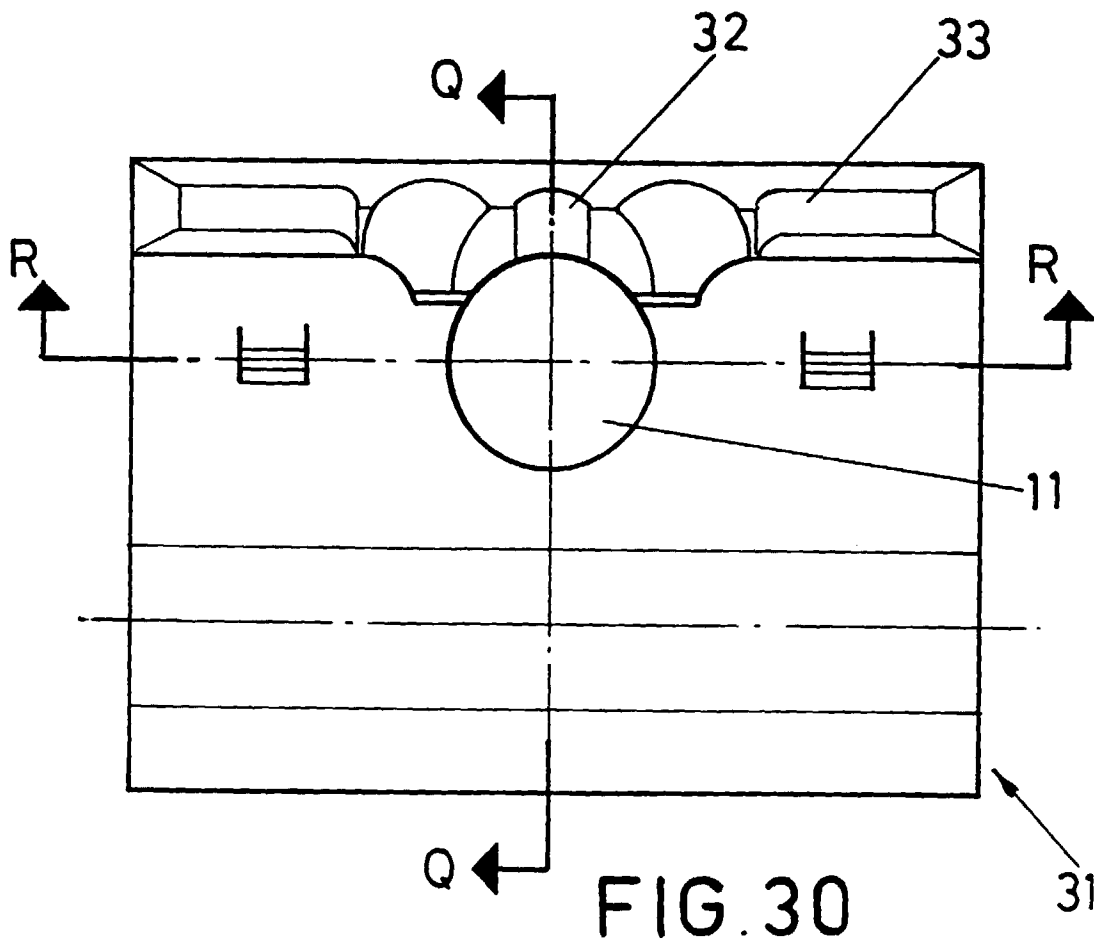

FIG. 29  
Q - Q



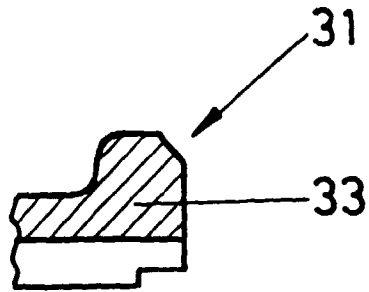

FIG. 32  
S-S

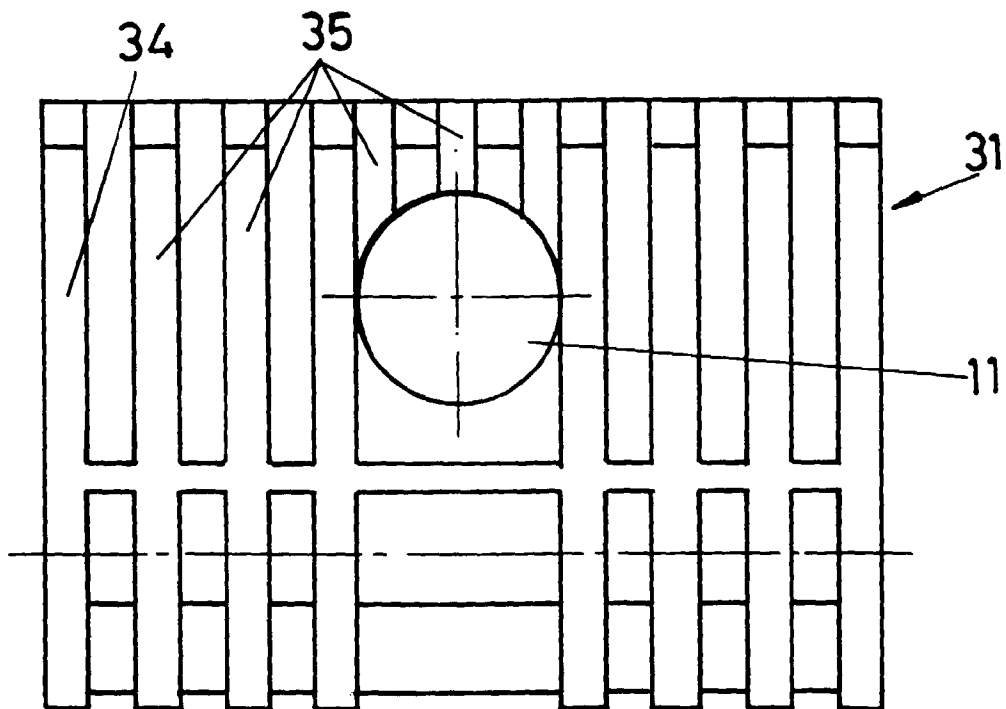
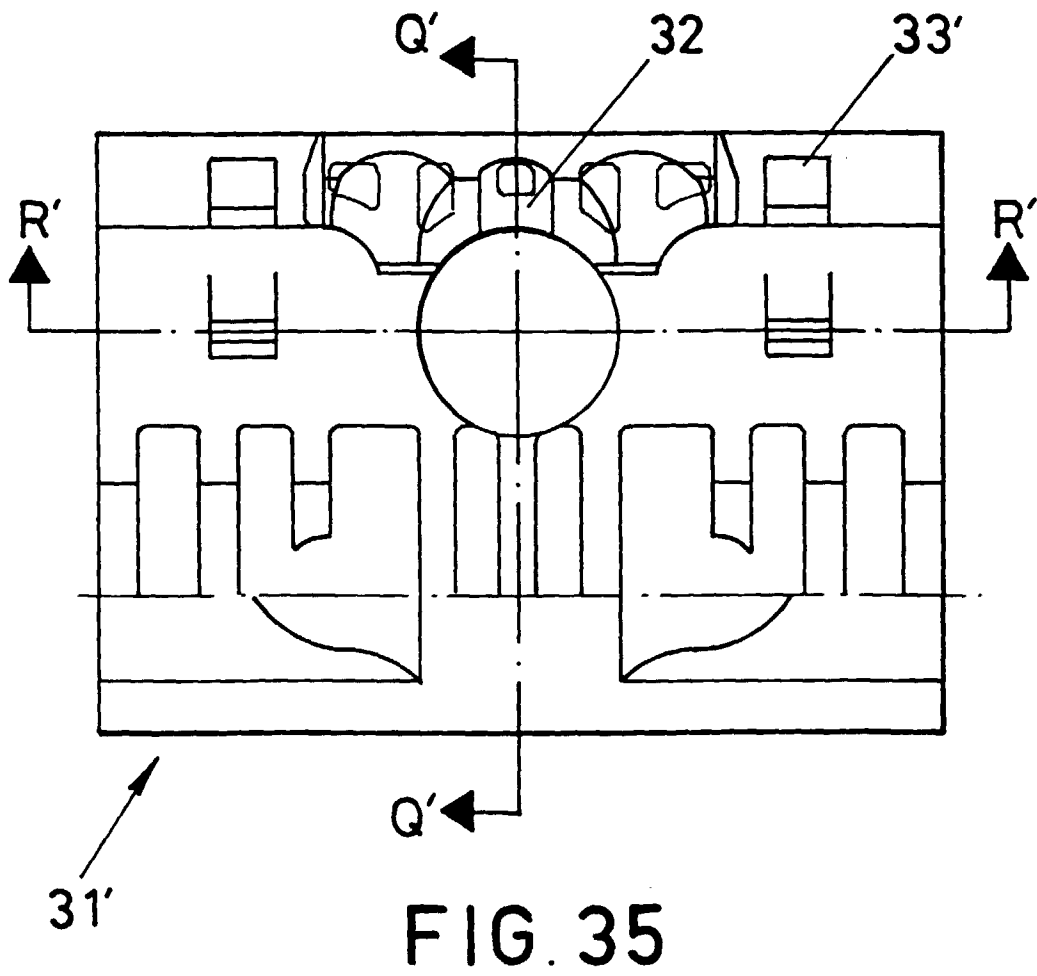
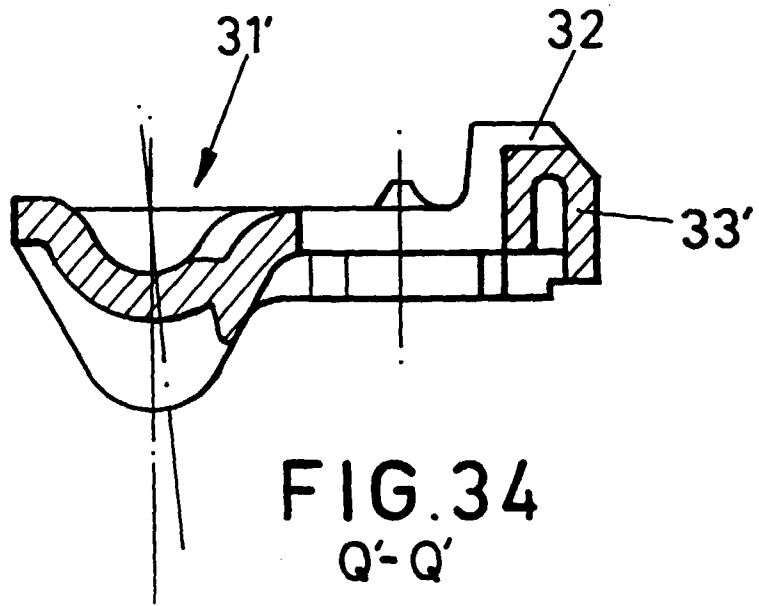

FIG. 33



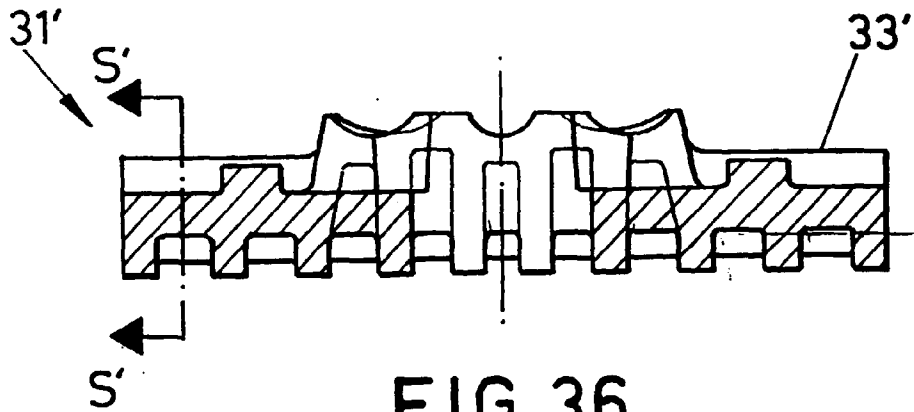

FIG. 36

R'-R'

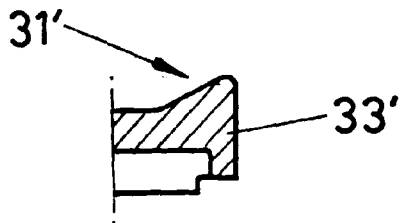

FIG. 37

S'-S'

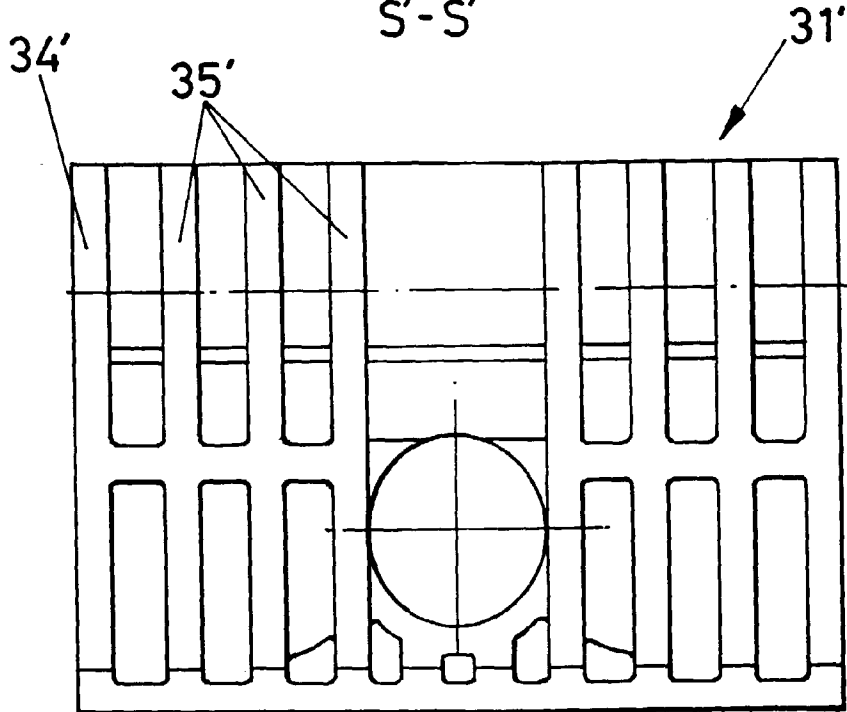

FIG. 38



European Patent  
Office

EUROPEAN SEARCH REPORT

Application Number  
EP 96 50 0128

DOCUMENTS CONSIDERED TO BE RELEVANT			
Category	Citation of document with indication, where appropriate, of relevant passages	Relevant to claim	CLASSIFICATION OF THE APPLICATION (Int.Cl.6)
A	DE-A-32 43 895 (VOSSLOH-WERKE ) * page 11, line 15 - page 14, line 5; figures 1-4 *	1	E01B9/30
A	DE-U-87 06 640 (WIRTHWEIN) * page 2, line 1 - page 5, line 24; figures 1-4 *	1	
A	EP-A-0 377 765 (WAYSS & FREYTAG)		
A	DE-A-39 03 297 (VOSSLOH-WERKE)		
			TECHNICAL FIELDS SEARCHED (Int.Cl.6)
			E01B
The present search report has been drawn up for all claims			
Place of search THE HAGUE		Date of completion of the search 16 December 1996	Examiner Kergueno, J
CATEGORY OF CITED DOCUMENTS		I : theory or principle underlying the invention E : earlier patent document, but published on, or after the filing date D : document cited in the application L : document cited for other reasons ..... & : member of the same patent family, corresponding document	
X : particularly relevant if taken alone Y : particularly relevant if combined with another document of the same category A : technological background O : non-written disclosure P : intermediate document			

EPO FORM 1503 03.82 (P04C01)