

(19)



Europäisches Patentamt

European Patent Office

Office européen des brevets



(11)

EP 0 795 364 A1

(12)

EUROPEAN PATENT APPLICATION

published in accordance with Art. 158(3) EPC

(43) Date of publication:

17.09.1997 Bulletin 1997/38

(51) Int. Cl.⁶: **B21D 3/05**, B21D 3/10

(21) Application number: **96931237.0**

(86) International application number:

PCT/JP96/02680

(22) Date of filing: **18.09.1996**

(87) International publication number:

WO 97/12701 (10.04.1997 Gazette 1997/16)

(84) Designated Contracting States:

DE GB LU NL

• **SHIKANO, Hiroshi**

Kashima-shi, Ibaraki 314 (JP)

(30) Priority: **29.09.1995 JP 253764/95**

28.12.1995 JP 343566/95

(74) Representative: **Berngruber, Otto, Dr. Dipl.-Chem.**

Patentanwälte

Haft, von Puttkamer

Berngruber, Czybulka

Franziskanerstrasse 38

81669 München (DE)

(71) Applicant: **SUMITOMO METAL INDUSTRIES, LTD.**
Osaka-Shi, Osaka 541 (JP)

(72) Inventors:

• **YUASA, Toru**

Sagamihara-shi, Kanagawa 229-11 (JP)

(54) **METHOD OF CORRECTING U-SHAPED STEEL SHEET PILE**

(57) Bending and warping of U-shaped steel sheet piles, particularly in U-shaped steel sheet piles having an arm portion can be efficiently corrected. In order to correct bending, a pressing force is applied to an outer surface of one of the flanges of the U-shaped steel sheet piles, and simultaneously a pressing force is applied to an inner surface of the other flange. For correction of warping, a roller straightener is used to restrict web and flange portions as well as arm portions from the lower and upper sides thereof.

Fig. 7

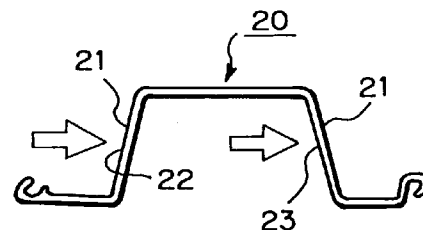

EP 0 795 364 A1

Description

(Technical Field)

5 The present invention relates to a method of reforming U-shaped steel sheet piles for use in civil engineering and building construction, and particularly to a method of reforming U-shaped steel sheet piles having an arm portion between a flange and a joint.

(Background Art)

10

Steel sheet piles are shaped by hot rolling and are cut to a predetermined length. While the cooling is taking place, warping or bending occurs in the longitudinal direction due to formation of internal stresses.

"Warping" means a large curve or edge curve in the direction perpendicular to the sheet pile wall 2 of a U-shaped steel sheet pile as illustrated by symbol "C" in Figure 1, and "bending" means a large curve or edge curve in the direction parallel to the sheet pile wall 2 of a U-shaped steel sheet pile as illustrated by symbol "B" in Figure 2. According to JIS A 5528, the tolerance for bending of U-shaped steel sheet piles is defined as being smaller than the length X 0.12% for steel sheet piles having a length of 10 m or less, and as being smaller than (length - 10 m) X 0.10% + 12 mm for steel sheet piles having a length over 10 m. The tolerance for warping of U-shaped steel sheet piles is defined as being smaller than the length X 0.25% for steel sheet piles having a length of 10 m or less, and as being smaller than (length - 10 m) X 0.20% + 25 mm for steel sheet piles having a length over 10 m.

Correction of these malformations is usually carried out using a roller straightener. However, since a straightener has, for example, four upper rollers and three lower rollers positioned in a zigzag arrangement, a satisfactory level of correction cannot be achieved for the front and rear ends of a pile. Especially, it is rather difficult to reform the bending and warping at the front and rear ends of a pile with a roller straightener, and it is general to reform the bending and warping at the front and rear ends with a press reformer after correction with a roller reformer.

Figure 3 illustrates correction of bending with a press reformer for a U-shaped steel sheet pile 1 to be reformed. In the illustrated case, a press rod (not shown) is provided to apply a pressing force in the direction shown by an arrow through a jig 5. On the opposite sides of the pile 1, jigs 6, 8 which support outer surface 4 of the flange of the U-shaped steel sheet pile 1 are provided to restrict movement of the pile.

30 However, in the case of a U-shaped steel sheet pile which possesses high rigidity against bending in the longitudinal direction, as shown in Figure 4a and Figure 4b, respectively, correction of bending cannot be achieved even if the outer surface 4 on the one side (see Figure 3) is pressed, but deformation of a sectional shape occurs such that the width of the pile to be reformed is narrowed from the standard width W_0 to the width W_1 shown by dashed lines. Furthermore, there occurs the problem that recesses D shown in Figure 4b are formed on the flange portions. These problems frequently occur when correction of bending is carried out for U-shaped steel piles having an arm portion between a flange and a joint.

There have been some proposals for correction of warping of U-shaped steel sheet piles. Japanese Patent Application Laid-Open Specification No. 61-63316, for example, discloses a roller straightener comprising a pair of upper and lower rollers having a correcting section with which a web portion and flange portions of U-shaped steel sheet piles are grasped. The roller straightener comprises a joint restricting section provided next to both sides of the correcting section of the upper roller, which restricts the joint portion of the U-shaped steel sheet pile. Japanese Patent Application Laid-Open Specification No. 55-70418 proposes a similar arrangement.

As shown in Figure 5, for example, straightening rollers 10 of U-shaped steel sheet piles are designed such that a web 12, flanges 14, and joints 16 are respectively restricted on their outer surfaces by a straightening roller 10a, 10b, 45 and a roller 18, each separated from each other, so as to achieve correction by repeating bending in longitudinal and transverse directions, and such that the width of a pile can be adjusted by rollers 18 which restrict the outer surfaces of the joint 16. As mentioned before, since correction is performed while restricting the web and flanges, malformation can be corrected without deformation of the sectional shape.

However, as shown in Figure 6, for U-shaped steel sheet piles having an arm 19 between a joint 16 and flange 14, the angle between the flange and the joint differs from a target one for a final product.

(Disclosure of the Invention)

55 A primary object of the present invention is to provide a new straightening method and a jig therefor, which can solve disadvantages of conventional methods and jigs for correcting bending in the longitudinal direction for U-shaped steel sheet piles.

A more definite object of the present invention is to provide a correcting method and a jig therefor, which can efficiently correct bending of U-shaped steel sheet piles, especially steel sheet piles having high stiffness in bending in the longitudinal direction, such as U-shaped steel sheet piles having an arm portion between flanges and a joint (claw).

A secondary object of the present invention is to provide a roller straightening method, which can achieve correction of warping without deformation of a sectional shape for U-shaped steel sheet piles having an arm portion.

The inventors completed the present invention based on the findings that in order to thoroughly correct bending of sheet piles having a high stiffness in bending in the longitudinal direction, it is effective to apply pressing force to the outer surface of one of the flanges as well as to apply pressing force to the inner surface of the other flange in the same direction.

Furthermore, the inventors studied the problem that the angle between a flange and a joint differs from that of the final product when warping is corrected using rollers for U-shaped steel sheet piles having an arm portion. The inventors completed the present invention based on the finding that it is not enough to merely restrict the full surfaces of the web and flanges, but that the correction of such an arm portion can be achieved precisely by means of restricting not only the web and flange, but also an arm portion with their full surfaces, and preferably by using a roller straightener having integrated upper and lower rollers.

Thus, the present invention is a method of straightening U-shaped steel sheet piles to correct bending in the longitudinal direction, the bending having been formed during hot rolling, characterized in that a pressing force is applied to the outer surface of one of the flanges of the U-shaped steel sheet piles, and simultaneously a pressing force is applied to the inner surface of the other flange.

In another aspect, the present invention is a correcting jig assembly for U-shaped steel sheet piles, comprising a first jig member having a surface to be pressed against the outer surface of one of the flanges of U-shaped steel sheet pile to be corrected, together with a second jig member which is connected to the first jig member, and which has a surface to be pressed against the inner surface of the other flange of the U-shaped steel sheet pile to be corrected.

In a preferred embodiment of the present invention, a fitting portion may be provided in a connecting portion between the first jig member and the second jig member so as to make it possible to connect and disconnect the second jig member having a surface to be pressed against the inner surface of a flange with the first jig member having a surface to be pressed against the outer surface of the other flange.

In another preferred embodiment, an adjusting mechanism may be provided in a connecting portion between the first jig member and the second jig member, which is able to adjust a relative position in the widthwise direction of the second jig member having a surface to be pressed against the inner surface of a flange with respect to the first jig member having a surface to be pressed against the outer surface of the other flange.

In still another aspect, the present invention is a method of correcting malformation of U-shaped steel sheet piles comprising a web portion, flange portions, and joint portions, and an arm portion between the flange portion and the joint portion, characterized by using a roller straightener by which not only the web and flange portions, but also the arm portion are restricted from the lower and upper sides thereof, and preferably by using a roller straightener having integrated upper and lower rollers.

In a preferred embodiment of the present invention, when the arm portion between the flange and joint portions is restricted, a straightening roller may be used to restrict the arm portion from the lower and upper side of the arm portion at an angle different from that required for a final product.

Thus, according to the roller straightening method of the present invention, straightening rollers which can achieve correction of malformation of U-shaped steel sheet piles by repeating bending in transverse and longitudinal directions comprises rollers restricting the upper side of the pile and rollers restricting the lower side of the pile, the upper and lower rollers being positioned in a zigzag arrangement.

(Brief Description of Drawings)

Figure 1 is a diagrammatic illustration of warping of steel sheet piles.

Figure 2 is a diagrammatic illustration of bending of steel sheet piles.

Figure 3 is a schematic view showing press correcting of bending of steel sheet piles.

Figure 4a illustrates a way of reducing the width of steel sheet piles by press straightening, and Figure 4b illustrates formation of local recesses in the surface of a flange.

Figure 5 is an illustration of conventional roller straightening for U-shaped steel sheet piles.

Figure 6 is an illustration of conventional roller straightening for U-shaped steel sheet piles having an arm portion.

Figure 7 is an illustration of press correcting according to the present invention.

Figure 8 is an illustration of an example of a jig assembly for press correcting in accordance with the present invention.

Figure 9 is an illustration of another example of a jig assembly for press correcting in accordance with the present invention.

Figure 10 is an illustration of an arrangement of correcting rollers and a U-shaped steel sheet having arms in accordance with the present invention.

Figures 11a and 11b are illustrations of upper and lower straightening rollers, respectively, for U-shaped steel sheet piles having arms in accordance with the present invention.

Figure 12 is an illustration of a section of a U-shaped steel sheet pile while correction is carried out with an upper roller.

Figure 13 is an illustration of a section of a U-shaped steel sheet pile while correction is carried out with a lower roller.

5 Figure 14 is a graph showing variation of an angle between an arm and a flange with respect to the longitudinal distance.

Figure 15 is a graph showing variation of width with respect to the longitudinal distance.

Figure 16 is a graph showing variation of an angle between an arm and a flange with respect to the longitudinal distance.

10 Figure 17 is a graph showing variation of width with respect to the longitudinal distance.

(Best Mode for Carrying Out the Invention)

15 According to the correcting method of the present invention, the pressing force shown by an arrow in Figure 7 is applied to the outer surface 22 of a flange 21 of a U-shaped steel sheet pile 20 to be corrected, and simultaneously a pressing force is applied to the inner surface 23 of the other flange 21 to push it in the same direction. Thus, a pressing force is applied to both flanges 21, 21 uniformly, and there is no narrowing in width or no local deformations such as recesses on the flanges 21, 21.

20 The strength of the pressing force applied to the outer surface 22 of one flange 21 may be equal to or larger than that applied to the inner surface 23 of the other flange 21 to some extent. Preferably, it is desirable that the same strength of pressing force be applied to both the inner and outer surfaces in order to avoid occurrence of changes in width of the product piles and local deformations on the flanges.

25 In this respect, according to conventional methods, as shown in Figure 3, since a pressing force is applied to only the outer surface of one of the flanges of a U-shaped steel sheet pile 1, there will occur local deformations such as recesses on the flange to which the pressing force has been applied, as shown in Figure 4b.

30 Figure 8 illustrates an example of a jig assembly which can be used in the correcting method of the present invention. The jig assembly comprises a first jig member 24 which comes in contact with and is pressed against the outer surface 22 of a flange 21 of U-shaped steel sheet pile 20 to be corrected, and a second jig member 25 which straddles over the one flange 21 and comes in contact with the inner surface 23 of the other flange 21. The first jig member 24 will be referred to as jig A, and the second jig member 25 will be referred to as jig B hereunder.

In Figure 8, jig A and jig B are suitably connected by a connecting section 26. In the embodiment shown in Figure 8, jigs A and B are suitably fitted and are fixed by a bolt 28 screwed through a screw hole 27 which is provided on the side of jig B. Any type of connection of the jigs, i.e., integrated types, fitting type, pin and pin hole type, etc. may be employed. The above-mentioned fitting + screw type is preferred, since it is the most simple and reliable among them.

35 Since the jigs are arranged as mentioned above, in the case shown in Figure 8, a pressing force is applied to a connecting site 29 provided on jig A through a press ram head in the direction shown by arrows.

In the illustrated embodiment, for easy handling, jig A and jig B are designed such that they are removable in the connecting section. Alternatively, they may have a one-piece structure.

40 In still another embodiment, instead of employing an arrangement in which jig A and jig B are fixed in the connection section, the two jigs may be loosely fitted together so that it is possible to adjust their relative positions. According to such an arrangement of the jigs, it is possible to suitably divide a pressing force into two parts based on a fluctuation in dimensions of sheet piles to be corrected, i.e., variation in width, which are simultaneously applied to an outer surface of one flange and to an inner surface of the other flange, so that it is possible to perform correction of bending efficiently without occurrence of local deformations of the sheet piles to be corrected.

45 Such an arrangement can be achieved, as shown in Figure 9, by employing a so-called sliding type connecting section 26 by which the relative position between jig A 24 and jig B 25 can slightly be adjusted as shown by an arrow, and their position can be fixed by a screw-type fixing mechanism (not shown), for example.

50 In order to correct bending of U-shaped steel sheet piles in either of the before-mentioned ways of pressing correction according to the present invention, as shown in Figure 8, when a U-shaped steel sheet pile 20 comes to a predetermined position after being transferred by a conveying roller R, the pile is fixed in its position by a jig assembly including jig A and jig B, and then a pressing force is applied in the direction shown by arrows. Fixing points by the jigs are provided, as shown in Figure 3, with one on a pressing side and two on a supporting side for the U-shaped steel sheet pile 20. Since correcting procedures can be performed in the same manner as in conventional methods, a further explanation of the correcting procedures will be omitted.

55 Although Figure 8 illustrates a steel sheet pile having an arm portion between a joint (claw) and a flange, the method of the present invention may be applied to a usual U-shaped steel sheet pile (without an arm portion), with modifications of the shape of jigs to some extent in conformity with the shape of a final product, resulting in the same effect as in the case of a pile with an arm. Furthermore, in the illustrated example, the sheet pile to be corrected is positioned in the form of an upright U, but it may be positioned in the form of a downward U. In the latter case, the top and bottom

of the jig members may be reversed in conformity with the reversed shape of the sheet pile to be corrected.

Next, rolling correction of warping of U-shaped steel sheet piles will be explained.

Figure 10 is an illustration of an arrangement of straightening rollers for U-shaped steel sheet piles having arms, as an example of a straightening roller of the present invention. In the drawings, a U-shaped steel sheet pile comprising a web 30, flanges 32, an arm 34, and joints 35 is restricted by upper rollers 36, 36, and lower rollers 38, 38 together with outer rollers 40 with respect to the web and flanges as well as the arms. In the illustrated embodiment, the upper and lower straightening rollers 36, 38 each have a one-piece construction so as to enable the web 30 and flanges 32 to be restricted with the same rollers.

When the angle between an arm 34 and a flange 32 before correction is different from that of a final product, each roller 36, 38 is provided with a tapered portion which restricts the arm 34, and correction by repeated bending can be carried out to correct the angle to be the same as that of the final product.

Figures 11a and 11b schematically show an example of such straightening rollers of the present invention. Compared with the case shown in Figure 10, it is noted that the rollers 36, 38 are provided with a tapered portion having an angle α .

In both cases, straightening rollers are used to restrict not only a web and flanges but also arms from above and below. Especially, in the case shown in Figures 11a and 11b, when an arm portion between flange and joint portions is restricted, straightening rollers are employed to restrict the arm from above and below at an angle different from that of the product.

It is to be noted that in the illustration the upper and lower rollers 36, 38 are shown as being positioned such that the roller axes are aligned in the same vertical plane, but in fact they are arranged in a zigzag pattern.

A method by which the roller straightening can be achieved efficiently by restricting the arm portion as described above will next be described.

Straightening by repeated bending is performed with the upper and lower rollers positioned in a zigzag form and contacting the pile at three points. An example will be described in which a correcting force is applied from the upper roller and the force is received by the lower rollers. In this case, as shown in Figure 12, if the arm 34 is not restricted, the angle between the arm 34 and the flange 32 decreases. Namely, the arm is deformed in such a way that an upstand angle θ of the arm 34 increases upwardly. In the drawing, the arm 34 is deformed in the direction shown by arrows. In contrast, if the arm 34 is restricted from above as well as from below in accordance with the present invention, the section of the U-shaped steel sheet pile can be maintained without occurrence of deformation.

In addition, when a correcting force is applied by the lower roller and the force is received by the upper rollers, as shown in Figure 13, if the arm 34 is not restricted, the angle between the arm 34 and the flange 36 increases. Namely, the arm is deformed in such a way that an upstand angle θ of the arm 34 increases downwardly. In the drawing, the arm 34 is deformed in the direction shown by arrows. In contrast, if the arm 34 is restricted in accordance with the present invention, the section of the U-shaped steel sheet pile can be maintained without occurrence of deformation.

Thus, according to the present invention, since arm portions together with web and flange portions are restricted, and preferably the web and flange portions are restricted by the same rollers from above and below, it is possible to achieve straightening without damage to the cross-sectional shape of a final product, as illustrated in Figures 12 and 13. Especially, when all portions other than the joint portions are restricted by the roller grooves, it is possible to efficiently correct not only warping in a vertical direction but also slight bending in a longitudinal direction.

According to the present invention, therefore, even for U-shaped steel sheet piles having arm portions and exhibiting high stiffness against bending and warping, compared with U-shaped piles without arms, it is easy to remove slight bending in a longitudinal direction as well as warping in a vertical direction by means of pressing correction or rolling correction and the arm portion can be maintained at a desired angle.

Examples

Effects of the present invention will be explained in detail with reference to the following working examples.

(Example 1)

Results of pressing correction of the present invention will be shown for U-shaped steel sheet piles having an arm portion between joint and flange portions.

The dimensions of sheet piles to be reformed are shown in Table 1. Pressing correction was carried out using a press machine comprising an oil hydraulic cylinder of the horizontal type. The distance between jigs on the receiving side (corresponding to the distance between jigs 6, 8 in Figure 3) was 1.2 m.

In order to remove bending in the longitudinal direction over the full length of the sheet pile to be reformed, pressing correction was carried out intermittently, while the sheet pile was transferred in the longitudinal direction in increments of 1.2 m after each pressing correction. A jig assembly used in the pressing correction of the present invention comprised jig A and jig B as shown in Figure 8. For comparison, a conventional method in which only jig A was employed

EP 0 795 364 A1

was carried out to remove bending in the longitudinal direction.

Table 2 shows bending in the longitudinal direction remaining in the final product after correction by the present invention method and the conventional method. As is apparent from the results shown in Table 2, bending was markedly reduced after correction in accordance with the present invention. In contrast, according to the conventional method, bending remained substantially unchanged even after correction, and instead, malformations such as fluctuations in width and local deformations in the flange surface were found in final products.

Table 1

Width	640 mm
Arm	90 mm
Height	200 mm
Length	15,000 mm
Specification	SY295 (JIS)
Note : Number of piles : 20	

Table 2

		Invention	Conventional
Before Correction	Average Bending	20 mm	18 mm
	Standard Deviation (σ)	2.1 mm	1.8 mm
	Other quality	No particular problems	No particular problems
After Correction	Average Bending	7 mm	16 mm
	Standard Deviation (σ)	0.4 mm	2.0 mm
	Other quality	No particular problems	Many malformations

(Example 2)

Pressing correction was carried out for a usual U-shaped steel sheet pile having no arm between joint and flange portions. The results thereof will be detailed as follows.

Dimensions of sheet piles to be corrected are shown in Table 3. In this example, pressing correction according to the present invention was carried out in order to remove bending in the longitudinal direction at both ends (about 1.2 m from the edge for each end) remaining after the preceding roller straightening. Regarding other procedures, Example 1 was repeated.

Table 4 shows bending in the longitudinal direction remaining in the final product after correction by the present invention method and the conventional method. As is apparent from the results shown in Table 4, bending at the edges was markedly reduced after correction in accordance with the present invention, and bending could be corrected in a short time. Thus, according to the present invention, correction of bending can be achieved efficiently.

Table 3

Width	550 mm
Height	250 mm
Length	12,000 mm
Specification	SY390 (JIS)
Note : Number of piles : 20	

Table 4

		Invention	Conventional
Before Correction	Average Bending	3 mm	2 mm
	Standard Deviation (σ)	0.5 mm	0.4 mm
	Other quality	No particular problems	No particular problems
After Correction	Average Bending	0.5 mm	1.0 mm
	Standard Deviation (σ)	0.1 mm	0.4 mm
	Other quality	No particular problems	No particular problems
Correcting Time		5 mins/piece	10 mins/piece

(Example 3)

In this example, roller correction according to the present invention was applied to U-shaped steel sheet piles having an arm between joint and flange portions.

The dimensions of sheet piles to be reformed are shown in Table 5.

Table 5

Width	640 mm
Arm	90 mm
Warping	10mm/15.3 m
Length	15,300 mm
Specification	SY295 (JIS)
Note : Number of piles : 20	

For comparison, conventional straightening rollers were used to restrict only a web and flanges separately, as shown in Figure 6. According to the present invention, however, a web and flanges were simultaneously restricted by the same rollers, i.e., by one-piece rollers, as shown in Figure 10, and an arm was also restricted by the same lower and upper rollers. The section of the pile after correction of bending was examined for the conventional method and the present invention method.

When straightening rollers of the present invention were used, warping in the longitudinal direction was completely removed, and the sectional shape of the arm and the width remained substantially unchanged.

When a web, flanges, and an arm were separately restricted by different upper rollers in accordance with an embodiment of the present invention, since it is impossible to restrict a border area between the web and the flange as

well as a border area between the flange and the arm with rollers, correction of warping with such separate rollers was not adequate.

Figure 14 shows variation of the angle between a flange and an arm with respect to longitudinal distance, and Figure 15 shows variation of width with respect to longitudinal distance.

5 Figure 14 is a graph obtained by plotting variation ($\Delta\theta$, degree) of an angle (θ) of an arm before and after correction with respect to longitudinal distance (L_0) of a U-shaped steel sheet pile. As is apparent from the graph, in the case of the present invention indicated by the symbol ●, variation was substantially constant regardless of the longitudinal distance. In contrast, in the conventional case indicated by the symbol ○, the arm was bent downwardly. Depending on the amount of reduction or a reduction pattern during correction, the arm was bent upwardly or downwardly in conventional methods (○), but the tendency of deformation was the same as in this case.

10 Figure 15 is a graph obtained by plotting variation (ΔW_0) in width (W_0) before and after correction with respect to longitudinal distance (L_0) of a U-shaped steel sheet pile. In the drawings, examples of the present invention are indicated by the symbol ●, and examples of the conventional method are indicated by the symbol ○. In the case of the present invention, there was substantially no variation.

15 Thus, according to the present invention, compared with the conventional method, the angle between flange portions and arm portion as well as the width remained unchanged, with good results.

(Example 4)

20 In this example, in the same manner as in Example 3, the straightening rollers shown in Figure 10, and straightening rollers having tapered portions shown in Figure 11 (taper angle is 3^0) were used to determine whether differences were found with respect to sectional shape after correction of bending.

In either case, warping in the longitudinal direction was successfully removed.

25 Figure 16 shows variation ($\Delta\theta$) of the angle (θ) of an arm before and after correction with respect to longitudinal distance (L_0), and Figure 17 shows variation (ΔW_0) of the width (W_0) before and after correction with respect to longitudinal distance (L_0). In the drawings, the symbol ● indicates the case in which a tapered portion was not provided, and the symbol "+" indicates the case in which rollers with tapered portions were employed. Depending on the amount of reduction or a reduction pattern during correction, the arm was bent upwardly or downwardly in the case in which the tapered portion was not provided (●), but the tendency of deformation was the same as in this case.

30 It is noted from these results shown therein that provision of a tapered portion has an effect to reduce the variation both of an angle of arm and of width.

(Industrial Applicability)

35 As is apparent from the above working examples, employing pressing correction and correction jigs of the present invention, it is possible to achieve correction of U-shaped steel sheet piles efficiently in a short time, and particularly, it is possible to achieve pressing correction effectively without occurrence of malformation even for steel sheet piles having a sectional shape with a high stiffness in bending in the longitudinal direction, such as U-shaped steel sheet piles having an arm portion. Thus, the present invention has a marked effectiveness from an industrial viewpoint.

40 Furthermore, correcting rollers of the present invention can be used to achieve roller correction of U-shaped steel sheet piles having an arm portion without changes in the sectional shape of the pile, i.e., the width size and the angle between arm and flange portions.

Claims

- 45
1. A method of straightening U-shaped steel sheet piles to correct in the longitudinal direction, the bending having been formed during hot rolling, characterized in that a pressing force is applied to an outer surface of one of the flanges of the U-shaped steel sheet piles, and simultaneously a pressing force is applied to an inner surface of the other flange.

50

 2. A correcting jig assembly for U-shaped steel sheet piles, characterized by comprising a first jig member having a surface to be pressed against an outer surface of one of the flanges of a U-shaped steel sheet pile, together with a second jig member which is connected to the first jig member, and which has a surface to be pressed against an inner surface of the other flange of the U-shaped steel sheet pile.

55

 3. A correcting jig assembly for U-shaped steel sheet piles as set forth in claim 2, characterized in that a fitting section is provided in a connecting portion between the first jig member and the second jig member so as to make it possible to connect and disconnect the second jig member having a surface to be pressed against the inner surface of a flange to and from the first jig member having a surface to be pressed against the outer surface of the other

flange.

- 5
4. A correcting jig assembly for U-shaped steel sheet piles as set forth in claim 2 or 3, characterized in that an adjusting mechanism is provided in a connecting portion between the first jig member and the second jig member, the adjusting mechanism being able to adjust a relative position in the widthwise direction of the second jig member having a surface to be pressed against the inner surface of a flange with respect to the first jig member having a surface to be pressed against the outer surface of the other flange.
- 10
5. A method of roller straightening U-shaped steel sheet piles comprising a web portion, flange portions, and joint portions, and an arm portion between the flange portion and the joint portion, characterized by using a roller straightener by which not only the web and flange portions, but also the arm portion are restricted from the lower and upper sides thereof.
- 15
6. A method of roller straightening U-shaped steel sheet piles as set forth in claim 5, wherein said roller straightener which restricts a web portion, flange portions and arm portions from the lower and upper sides thereof comprises an integrated upper roller and an integrated lower roller.
- 20
7. A method of roller straightening U-shaped steel sheet piles as set forth in claim 5, wherein said roller straightener comprises upper and lower rollers which are positioned in a zigzag form in the upper and lower sides.
- 25
8. A method of roller straightening U-shaped steel sheet piles as set forth in claim 5, characterized in that when the arm portion between the flange and joint portions is restricted, a straightening roller is used to restrict the arm portion from the lower and upper sides of the arm portion at an angle different from that required for a final product.
- 30
9. A method of roller straightening U-shaped steel sheet piles as set forth in claim 8, characterized in that said straightening rollers restricting the web and flange portions as well as the arm portions from the upper and lower sides comprise an integrated upper roller and an integrated lower roller.
- 35
- 40
- 45
- 50
- 55
10. A method of roller straightening U-shaped steel sheet piles as set forth in claim 8, wherein said roller straightener comprises upper and lower rollers which are positioned in a zigzag form in the upper and lower sides.

Fig. 1

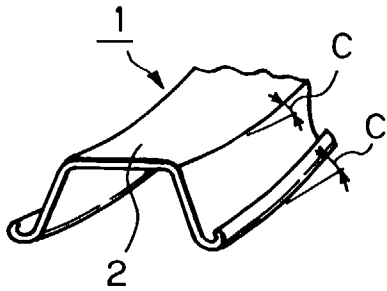

Fig. 2

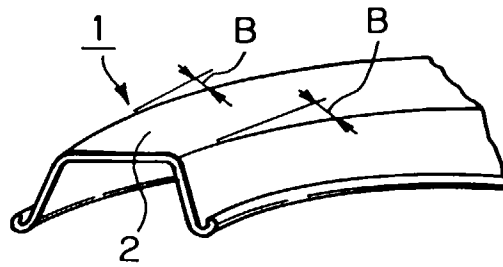

Fig. 3

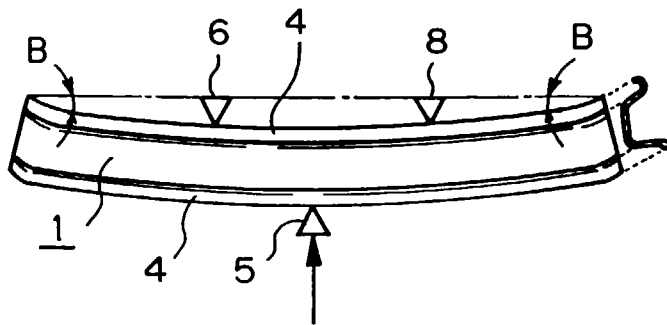

Fig. 4(a)

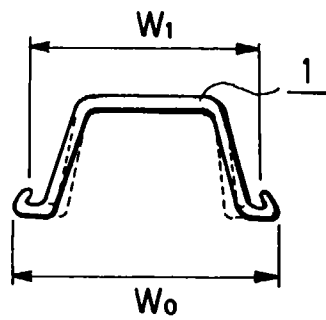

Fig. 4(b)

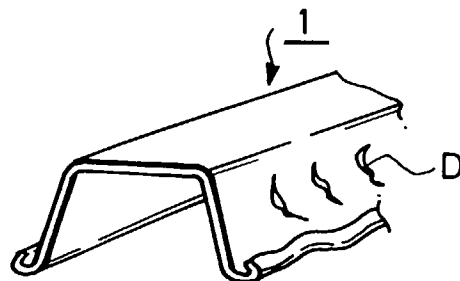

Fig. 5

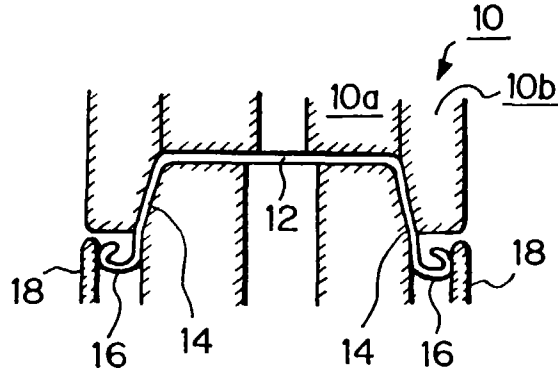

Fig. 6

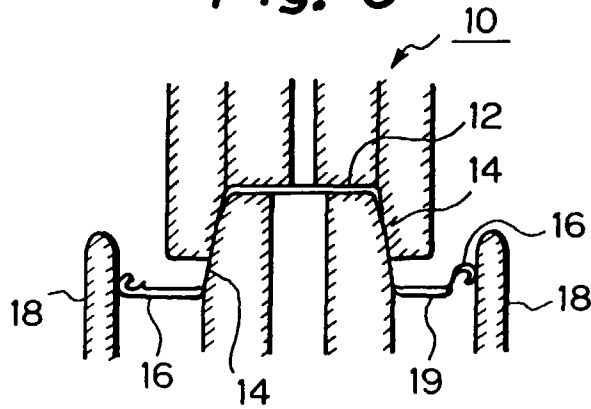

Fig. 7

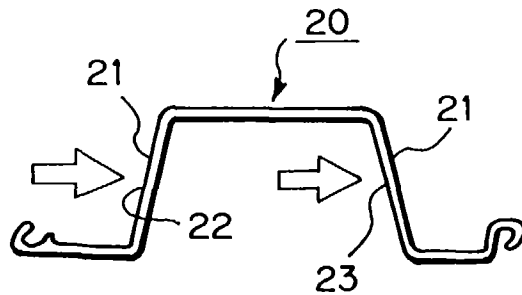

Fig. 8

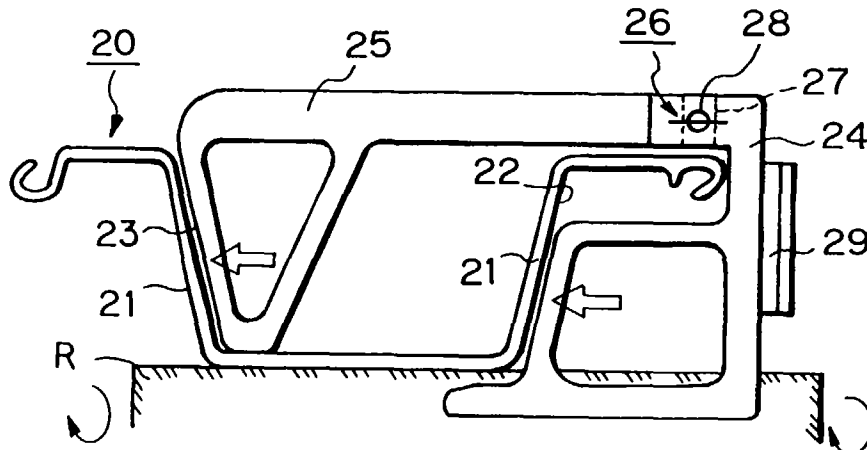

Fig. 9

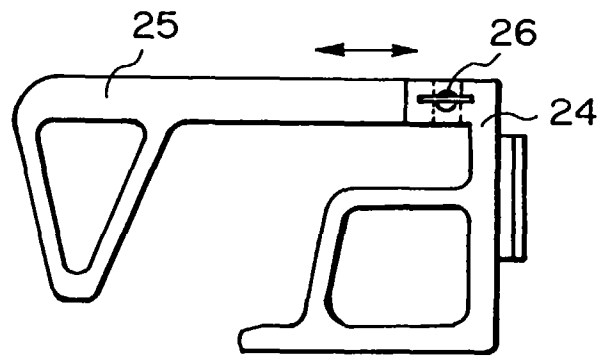

Fig. 10

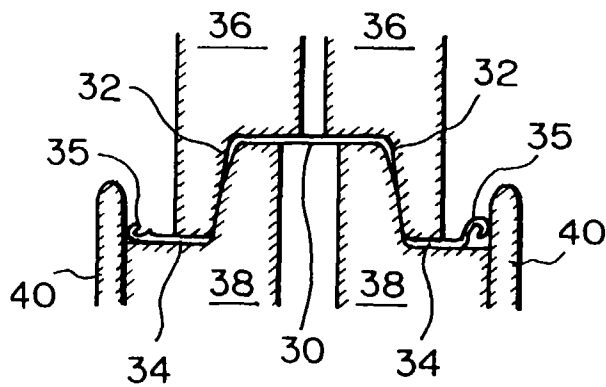

Fig. 11(a)

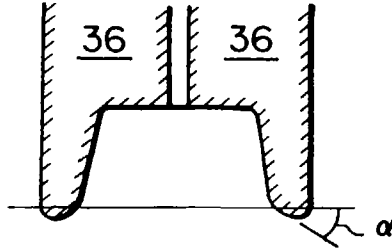

Fig. 11(b)

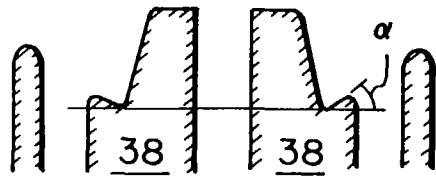

Fig. 12

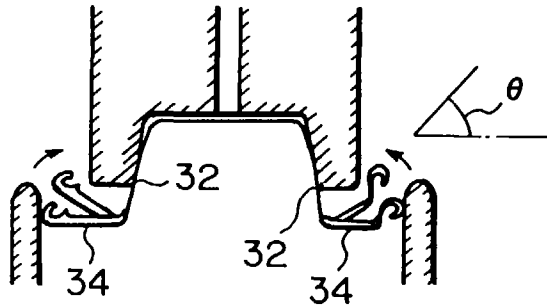

Fig. 13

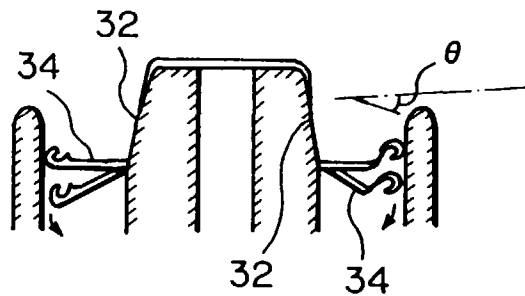

Fig. 14

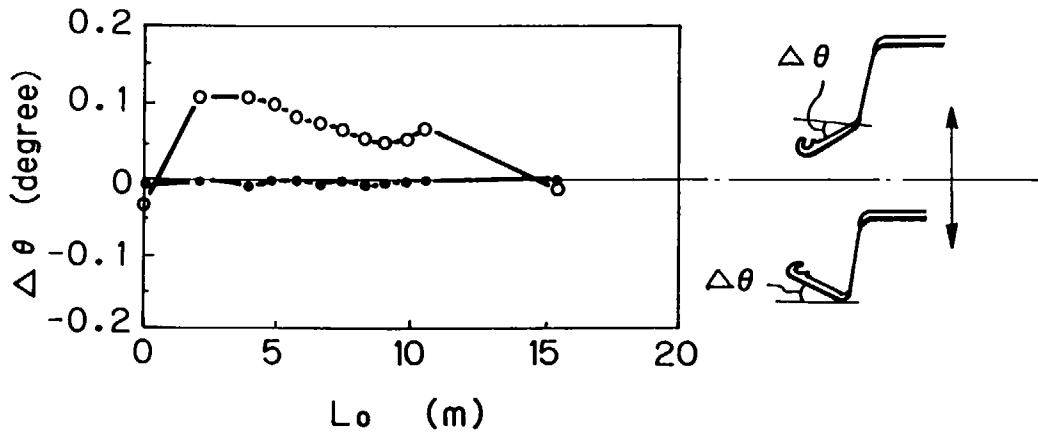

Fig. 15

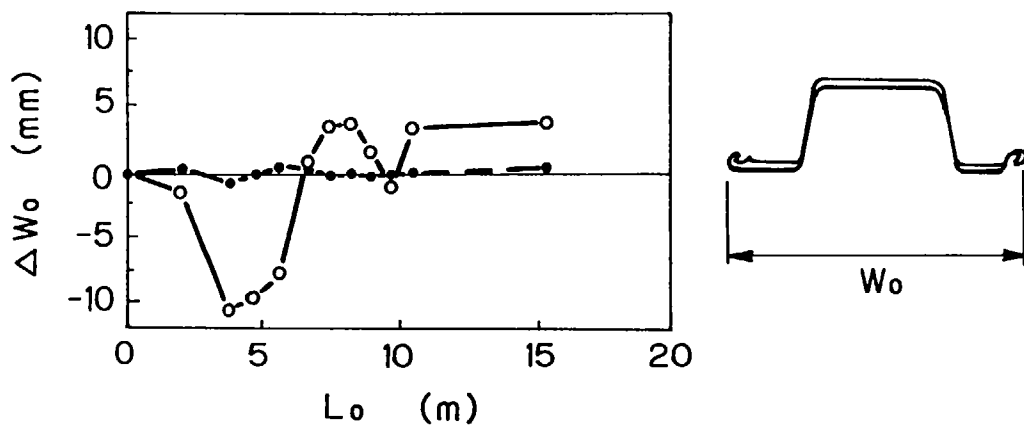

Fig. 16

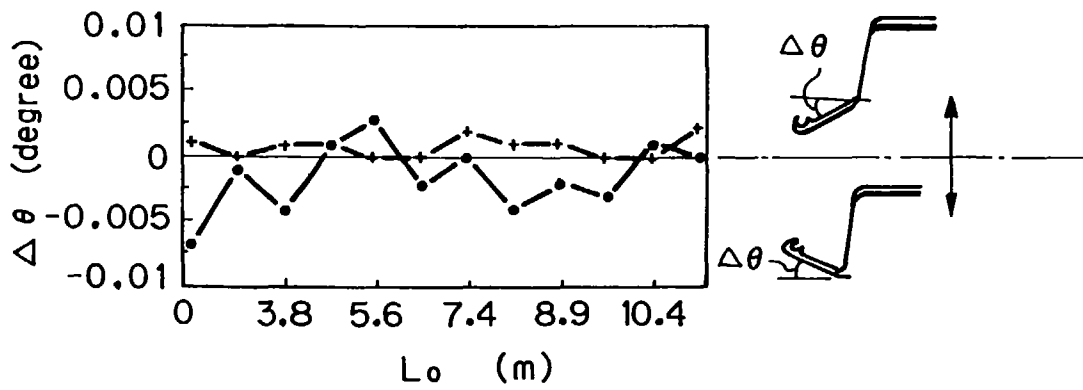
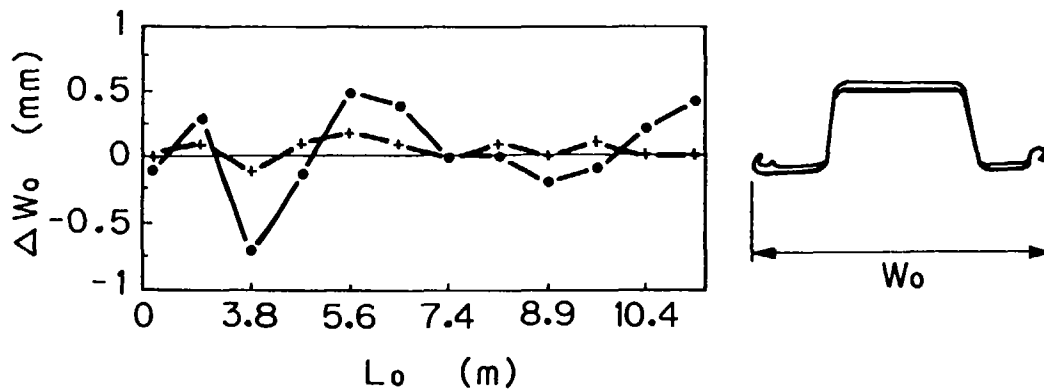

Fig. 17



INTERNATIONAL SEARCH REPORT

International application No.

PCT/JP96/02680

A. CLASSIFICATION OF SUBJECT MATTER	
Int. Cl ⁶ B21D3/05, 3/10	
According to International Patent Classification (IPC) or to both national classification and IPC	
B. FIELDS SEARCHED	
Minimum documentation searched (classification system followed by classification symbols)	
Int. Cl ⁶ B21D3/00-3/16	
Documentation searched other than minimum documentation to the extent that such documents are included in the fields searched	
Jitsuyo Shinan Koho 1926 - 1996 Jitsuyo Shinan Toroku Kokai Jitsuyo Shinan Koho 1971 - 1996 Koho 1996 Toroku Jitsuyo Shinan Koho 1994 - 1996	
Electronic data base consulted during the international search (name of data base and, where practicable, search terms used)	
C. DOCUMENTS CONSIDERED TO BE RELEVANT	
Category*	Citation of document, with indication, where appropriate, of the relevant passages
A	JP, 54-76471, A (Sumitomo Metal Industries, Ltd.), June 19, 1979 (19. 06. 79) (Family: none)
A	JP, 61-63316, A (Kawasaki Steel Corp.), April 1, 1986 (01. 04. 86) (Family: none)
A	JP, 55-70418, A (NKK Corp.), May 27, 1980 (27. 05. 80) (Family: none)
A	JP, 53-79759, A (Nippon Steel Corp.), July 14, 1978 (14. 07. 78) (Family: none)
A	JP, 50-70261, A (Nippon Steel Corp.), June 11, 1975 (11. 06. 75) (Family: none)
A	JP, 56-100222, U (Nippon Steel Corp.), August 7, 1981 (07. 08. 81) (Family: none)
	Relevant to claim No.
	1 - 10
	1 - 10
	1 - 10
	1 - 10
	1 - 10
	1 - 4
<input type="checkbox"/> Further documents are listed in the continuation of Box C. <input type="checkbox"/> See patent family annex.	
* Special categories of cited documents: "A" document defining the general state of the art which is not considered to be of particular relevance "E" earlier document but published on or after the international filing date "L" document which may throw doubts on priority claim(s) or which is cited to establish the publication date of another citation or other special reason (as specified) "O" document referring to an oral disclosure, use, exhibition or other means "P" document published prior to the international filing date but later than the priority date claimed "T" later document published after the international filing date or priority date and not in conflict with the application but cited to understand the principle or theory underlying the invention "X" document of particular relevance; the claimed invention cannot be considered novel or cannot be considered to involve an inventive step when the document is taken alone "Y" document of particular relevance; the claimed invention cannot be considered to involve an inventive step when the document is combined with one or more other such documents, such combination being obvious to a person skilled in the art "&" document member of the same patent family	
Date of the actual completion of the international search	Date of mailing of the international search report
December 13, 1996 (13. 12. 96)	December 25, 1996 (25. 12. 96)
Name and mailing address of the ISA/ Japanese Patent Office	Authorized officer
Facsimile No.	Telephone No.

Form PCT/ISA/210 (second sheet) (July 1992)