



(12) EUROPEAN PATENT APPLICATION

(43) Date of publication:  
17.09.1997 Bulletin 1997/38

(51) Int. Cl.<sup>6</sup>: G07D 11/00

(21) Application number: 97103017.6

(22) Date of filing: 25.02.1997

(84) Designated Contracting States:  
AT BE CH DE ES FR GB LI SE

(72) Inventors:  
• Ceradelli, Vittorio  
I-10010 Cascinette D'lvrea (IT)  
• Colecchia, Enrico  
I-10010 Fiorano Canavese (IT)

(30) Priority: 13.03.1996 IT TO960185

(71) Applicant: CTS electronics srl  
10015 Ivrea (TO) (IT)

(74) Representative: Nola, Eduardo  
Via IV Novembre 23  
10010 Burolo (Turin) (IT)

(54) Acquisition and/or issuing device for banknotes

(57) An acquisition and/or issuing device (11) comprises a taking-up roll (50) and a feeding roll (51) adapted to rotate around fixed axes, a transport belt (52) and a pair of pinch rollers (53, 54). The taking-up roll (50) can store banknotes (12) or other flexible documents in a spool (57) together with the transport belt (52) and one of the pinch rollers (53, 54) is moved by an electromagnet (79). Electronic means (69) control the

electromagnet and the rotation of the taking-up and feeding rolls, and associate the engagement and disengagement configuration of the pinch rollers (53, 54) with a banknote (12) to the revealing of the banknote by two sensors (66, 67). An accompanying roller (74) makes easier the winding of the banknotes (12) in the spool (57).

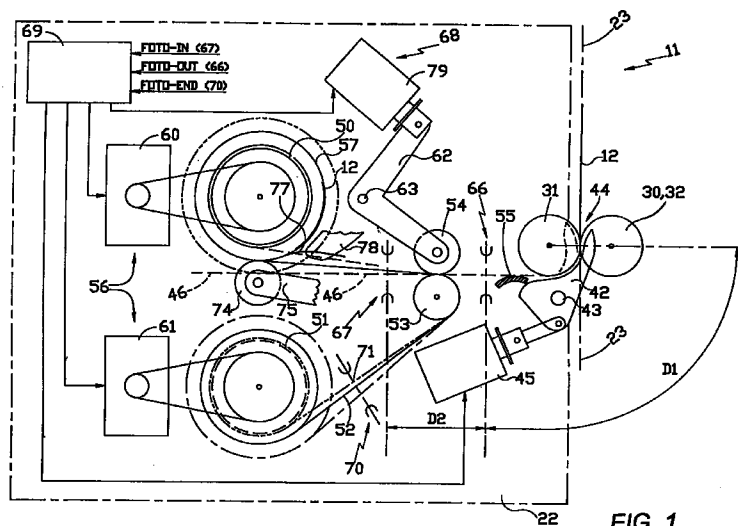

FIG. 1

## Description

The present invention relates to an acquisition and/or issuing device for banknotes or other flexible documents.

More specifically, object of the invention is an acquisition and/or issuing device for banknotes or other flexible documents comprising a taking-up roll, a feeding roll, at least a transport belt susceptible of winding and unwinding between said rolls and a pair of pinch rollers, said taking-up roll being adapted to store the banknotes in a spool together with the said belt.

From US Patent 4,337,864 an acquisition and/or issuing device of the above mentioned type is known which is included in an ATM system for dispensing and storing banknotes. The banknotes are moved by transport belts powered by the system, whilst the taking-up roll, the feeding roll and the pinch rollers are mounted on a removable cartridge. These rollers are adjacent to a passage slot of the cartridge and the banknotes are transported through the slot owing to the joined engagement of the pinch rollers and the transport belts. The ATM system puts in rotation one of the pinch rollers and the taking-up roll or the feeding roll for storing or dispensing the banknotes. At the same time, the system brakes the taking-up roll or the feeding roll not powered so as to maintain taut the transport belt.

In this known device, the cinematic components of the ATM system and the ones of the cartridge require relevant constraints for obtaining the necessary synchronism. It causes serious problems when the system provides more acquisition and/or storing devices, which operate in parallel.

Object of the present invention is that of providing an acquisition and/or issuing device for banknotes of improved type, quick and of high reliability, which results of limited dimensions and independent of constraints by the system where it is used.

This object is achieved, according to the invention, by the acquisition and/or issuing device for banknotes of the above mentioned type, which is characterised in that the pinch rollers are moveable reciprocally between an engagement configuration for the banknotes on the transport belt and a disengagement configuration. The device comprises first and second sensor means disposed in a path for the banknotes for providing presence information of the banknote, and actuating means for the engagement and the disengagement configuration of the pinch rollers. Electronic means control the actuating means and the rotation of the taking-up and the feeding rolls, by associating the engagement and disengagement configuration to the presence information of a banknote revealed by the first and/or the second sensor means.

With the acquisition and/or issuing device of the present invention the banknotes are transported in an asynchronous mode with respect to the banknotes of the system where it is used. Therefore this device can operate reliably and at reduced costs also when their

cinematic components are driven at various velocities and different from the ones of the system.

According to another characteristic, the device comprises stepping motors for the rotation of the taking-up and feeding rolls, sensing means disposed in the path of the banknotes for revealing the passage of a banknote through a given revealing zone; and electronic means for controlling said stepping motors. The electronic means include counting means conditioned by the sensing means for revealing a number of reference steps of one of the motors associated to the passage of a banknote of pre-defined height, and means conditioned by the counting means for defining steps of the motor associated to the movement of a following banknote.

Further characteristics and advantages of the device according to the invention will be clear by the detailed description which follows, made with reference to the enclosed drawings, given exclusively as not limiting example, in which:

the figure 1 is a schematic view which shows an acquisition and/or issuing device for banknotes according to the invention;

the figure 2 is a schematic planar view of the device of figure 1;

the figure 3 is a schematic view of a system for the automation of cash activities, which uses any of the devices of figure 1, in a first configuration;

the figure 4 is a schematic view of the system of figure 3, which uses any of the devices of figure 1, in a second configuration;

the figure 5 is an electric block diagram of the acquisition and/or issuing device for banknotes according to the invention;

the figure 6 is an operative diagram of the device according to the invention;

the figure 7 is a schematic view which shows an embodiment example of the acquisition and/or issuing device for banknotes according to the invention, in a working condition; and

the figure 8 is a schematic view which shows the device of figure 7 in another working condition.

An acquisition and/or issuing device 11 for banknotes 12 or other flexible documents is shown in the figure 1 by way of example and in a schematic shape. Such device can be used in a system 13 (Figs. 3 and 4) for the automation of cash activities including, inter alia, a safe-housing 14.

In the system 13, the safe-housing 14 has an upper body for the acquisition/issuing of the banknotes with respect to an operator, and a lower body for the storing of the banknotes and which constitutes a real safe 17. The banknotes can be moved between the two bodies through a central opening 18 in an upper part of the safe 17.

Specifically, the upper body of the safe-housing 14 includes an input vane 15 for temporary storing and

entering the banknotes and two output vanes 16 for their issuing. In this upper body are also lodged an electronic control unit 19 and mechanisms, not shown in the figures, which provide to move the banknotes between the vanes 15 or 16 and the opening 18.

The safe 17 includes internally a plurality of lodgements 20 and a transport mechanism 21 controlled by the electronic unit 19, for moving the banknotes 12. Each lodgement 20 is adapted to contain a drawer 22 and a respective device 11 for storing the banknotes 12.

In a phase of acquisition, the banknotes are taken from the input vane 15 and distributed among the drawers 22 and, in a phase of issuing, the banknotes are conveyed from the drawers 22 toward the output vanes 16.

The safe 17 provides, for example, six lodgements 20 laid one upon the other, disposed according to two columns of three lodgements for each side. The drawers 22 are accessible through a front door of the safe, not shown in the figures. The mechanism 21 is adapted to move the banknotes 12 along a vertical path 23 disposed between the two columns of lodgements 20, aligned with the opening 18.

The transport mechanism 21 comprises a stepping motor 24 fixed on a rear wall of the safe 17 adjacent to the opening 18 and a toothed belt 25. In particular, a toothed pulley is fixed on the axis of the motor 24 and engages with teeth of the toothed belt 25 and the belt 25 is also engaged with a return pulley 26 and a tauting pulley 27.

The pulleys 26 and 27 are disposed adjacent to the opening 18 at the rear wall of the safe 17, respectively. By this way, the belt 25 defines two main branches which extends substantially vertically for all the height of the rear wall of the safe 17. A first branch of the belt 25 extends between the pulleys 26 and 27 along the path 23, whilst the second branch extends between the pulleys 26 and 27 along the path 23 on the motor 24 and the tauting pulley 27.

The transport mechanism 21 also comprises a pair of transport rollers 28 adjacent to the opening 18 and a pressure pulley 29. The transport rollers 28 are in reciprocal engagement and by opposite sides with respect to the path 23 and are rotatably connected with the pulley 26 through an intermediate gear. The pressure roller 29 is keyed on the return pulley 26 and is disposed at a side of the path 23 immediately below the transport rollers 28.

The drawers 22 are of parallelepiped shape and comprise two support sides 48 and 49, left and right and an open side, directed towards the path 23 for the access to the device 11. Each drawer 22 is supported by guides of the lodgements 20 and through notches which allow their approaching and withdrawal, perpendicularly to the path 23. Moreover, the three drawers 22 of a column are a little offset in height with respect to the drawers of the other column.

Relatively to the path of the banknotes 12, the drawers 22 are moveable between a disengagement condition in which the open side is away from the path

23 and an engagement condition in which the open side is adjacent to the path 23. The disengagement condition allows the removal and the insertion of the drawers 22, transversely to the guides of the lodgements 20. The engagement condition is a working condition for the device 11 and in which the drawers can be stable locked in the lodgements 20 by a mechanism not shown in the figures.

Each drawer 22 comprises, adjacent to the open side, a series of four transport rollers 30, 31, 32 and 33, disposed according to parallel axes equidistant and laying on a plane parallel to the plane of the open side. The roller 31 has a mover function and is interconnected in the rotation with the roller 33 by toothed pulleys and belts not shown in the figures.

The rollers 30-33 are powered bi-directionally by the mechanism 21 of the system 13. To this end, the belt 25 is toothed also in the surface opposite to the one engaged with the pulleys 26 and 27. Each drawer 22 presents, externally to the right or left side and directed towards the rear wall, a toothed pulley 34 bodily connected in the rotation with the roller 31 and engageable with the of the belt 25. In detail, the pulleys of the drawers at left engage the external teeth and the pulleys of the drawers at right engage the internal teeth of the belt 25.

Near to each lodgement 20, the belt 25 has a rectilinear path when the drawer 22 is missing or is in the disengagement condition, as indicated in figure 4. In the engagement condition of the drawer 21, its toothed pulley 34 imposes a "V" deviated path to the belt 25. The tauting pulley 27 is provided to maintain the branch of the belt disposed along the path 23 to a tension sufficient for transferring the movement from the belt to the pulleys 34, independently of the number of the mounted drawers 22.

The rollers 30, 31, 32 and 33 of a drawer 22 disposed at a side of the path 23 are engageable under pressure with as many rollers disposed on the opposite side of the path.

In view of the offset between the drawers of the two columns, the rollers 31, 32 and 33 of the three drawers at the left side are contrasted by the rollers 30, 31 and 32 of the three drawers at the right side. However, the roller 30 of the first drawer at left, highest in the figure is contrasted by the pressure roller 29 of the transport mechanism 21 and the rollers 30 of the second and third drawer at left are contrasted by the rollers 33 of the first and second drawer at right.

By this way, when the drawers 22 are in their engagement conditions, all the rollers 30-33 are adapted to transport the banknotes 12 along the path 23, without solution of continuity.

Each drawer 22 comprises a selection flap 42, in an interface zone 44 (Fig. 1), between the rollers 31 and 32, corresponding to an engagement area of a roller 31, with the pressure roller 29 of the transport mechanism 21 or the roller 30 or 32 of the drawer of the other column. The flap 42 is fulcrumed on an axis 43 and is

moveable between two positions by an electromagnet 45, to deviate the banknotes 12 from the vertical path 23 to a path 46 internal to the drawer 22 and having an approximately horizontal trend.

The above-mentioned structure is common to the drawers 22 (Fig. 3) of the two columns. The sole difference is the localisation of the toothed pulley 34: at the support side 48 for the drawers assigned to the left lodgements 20 and at the support side 49 for the drawers assigned to the right lodgements. The drawers 22 can be made identical if two toothed pulleys 34 are provided for the rollers 31: one at the side 48 and another at the side 49.

By this way, the insertion of the drawers 22 in the lodgements 20 and their powering result particularly easy. Further, the transport mechanism 21 results devoid of clutches for the powering of the device 11.

In an acquisition phased the system 13 is adapted to move the banknotes 12 in the direct sense from the top towards the bottom along the path 23, imposing a counterclockwise sense of motion to the motor 21 for the belt 25, which causes a clockwise sense of motion to the rollers 30-33 of the drawers at the left in the figure and a clockwise sense of motion to the rollers 30-33 of the drawers at the right.

The system 13 is provided to recognise the types of treated banknotes and position the selection flaps 42 for distributing them selectively from the path 23 to the various drawers 22 on the basis of the typology, for being acquired by the respective devices 11.

Likewise, in an issuing phase, the system 13 is adapted to move the banknotes 12 in the direct sense from the bottom towards the top along the path 23, imposing to the motor 21 a clockwise sense of motion for the belt 25, which generates a counterclockwise motion to the rollers 30-33 of the drawers at left in figure and a clockwise sense of motion to the rollers 30-33 of the drawers at right. Then, the actuation of an electromagnet 45 allows the relevant device 11, when operative, to issuing the banknotes from the drawer 22 towards the path 23.

With reference to the views of the figures 1 and 2, the device 11 is mounted between the sides 48 and 49 of the drawer 22 and comprises a taking-up roll 50 for the banknotes 12, a feeding roll 51, at least a transport belt 52, a pair of pinch rollers 53 and 54, a guide tile 55 and mover means 56 for the taking-up and feeding rolls.

The rolls 50 and 51 are susceptible of rotation around parallel axes fixed between the sides 48 and 49 of the drawer 22 and which, in use, lies at different heights, respectively, above and below the path 46 for the banknotes 12. Also the pinch rollers 53 and 54 rotate on parallel axes below and above the path 46, at a side of the rolls 50 and 51, respectively.

The transport belt 52 is susceptible of winding and unwinding between the taking-up roll 50 and the feeding roll 51 and cooperates with the pinch roller 53 having a returning function. By way of example, the belt 52 comprises two thin bands of transparent and strength plastic

material which operate in parallel, side by side.

The bands are preferably films of mylar and have respective opaque ends fixed to the rolls 50 and 51.

The taking-up roll 50 is adapted to store the banknotes 12 in a spool designated as 57, together with the two bands which constitute the belt 52. The pinch rollers 53 and 54 are rotatable around parallel axes and are faced each the other in the path 46 of the banknotes included between the interface zone 44 and the taking-up roll 50.

The mover means 56 comprise two stepping motors 60 and 61 for putting in rotation the taking-up roll 50 and the feeding roll 51 through toothed pulleys and belts, respectively, not described in detail.

By means of this structure, the path 46 for each banknote 12 has a first portion included between the interface zone 44 and the pinch rollers 53 and 54 which is limited by the selection flap 42, and a second portion included between the rollers 53 and 54 and the taking-up roll 50 which is limited by the belt 52.

According to an aspect of the invention, the rollers of the pair of pinch rollers 53 and 54 are susceptible of reciprocal movement between an engagement configuration pinching the banknotes 12 and a disengagement configuration.

By way of example, the roller 53 with returning function is mounted on an axis rotatably supported between the support sides 48 and 49 and, in its upper portion, results tangent to the path 46. The roller 54 has a function of pressure roller and is supported by a bridge 62 fulcrumed on an axis 63 also mounted between the sides 48 and 49 and biased by a spring towards the roller 53.

In the engagement configuration, the roller 54 is adapted to engage the bands constituting the belt 52 resting on the portion of the roller 53 which is tangent to the path 46. By this way, the belt 52 is adapted to transport with it, by adhesion, a banknote 12 interposed between the same belt and the roller 54.

In the disengagement configuration, the roller 54 is away from the roller 53. Therefore, a banknote 12 interposed between the roller 53 and the bands constituting the belt 52 can slide with weak friction on the belt 52 and the guide tile 55.

Suitably, the device 11 comprises first and second sensors 66 and 67 for revealing the presence of the banknotes 12 in respective detection areas, actuating means 68 for the engagement and disengagement configurations of the pinch rollers 53 and 54 and electronic means 69 for controlling the mover means 56 and the actuating means 68.

The sensors 66 and 67 are of photoelectric type and, by way of example, comprise each one a LED and a phototransistor disposed above and below the path 46 for the banknotes 12, at a short distance therefrom. The sensor 66 is disposed between the interface zone 44 and the pair of pinch rollers 53 and 54 and the sensor 67 is disposed between the pair of rollers 53 and 54 and the taking-up roll 50.

The sensors 66 and 67 are adapted to supply a signal FOTO-OUT and a signal FOTO-IN, respectively, when a whatsoever portion of a banknote 12 is interposed between the LED and the phototransistor, in the respective detection area.

A further sensor 70 is also provided for revealing the passage of an end portion 71 of the belt, by feeding a signal FOTO-END. The portions 71 are located near to the ends of the belt 52 fixed on the rolls 50 and 51. The sensor 70 is also of photoelectric type and comprises a LED and a phototransistor disposed above and below one of the two bands which constitute the belt 52.

The portions 71 are constituted by the opaque terminal portions of the band sensed by the sensor 70. Therefore, the signal FOTO-END results associated either to a full condition and a void condition for the roll 50, as will be described later.

Further, the device 11 comprises an accompanying roller 74 having an axis rotatably supported by a pair of lever arms 75. The arms 75 are urged by a spring for moving the roller 74 perpendicularly to its axis so as to cooperate with the outermost coils of the belt and banknotes spool 57 wound on the roll 50. In particular, the roller 74 bears on the tangency zone of the spool 57 with the portion of belt 52 directed towards the roller 53. It allows, in the acquisition phase, a good adherence of the banknotes 12 to the spool 57 wound on the roll 50, for each winding condition of the roll 50.

The device 11 presents also a stripping blade 77 for each one of the bands constituting the belt 52, supported by a pair of lever arms 78. The two blades are adapted to cooperate with the outermost coils of the spool 57 wound on the roll 50, in an area adjacent to the roller 74 and by opposite side with respect to the belt 52.

Each lamina 77 has a terminal edge in pressure engagement with the roll 50, extends for a given distance along the path 46 and makes easier, in the issuing phases, detaching the banknotes 12 from the spool 57 and resting them on the belt 52. Further, the lever arms 78 are shaped to make easier, in the acquisition phases, the winding of the banknotes on the spool 57.

The actuating means 68 comprise, by way of example, an electromagnet 79 which, when it is de-energised, ensures the pressure engagement configuration for the rollers 53 and 54. When the electromagnet 79 is energised, it ensures the disengagement configuration, by withdrawing the roller 54 from the roller 53 through the bridge 62.

With reference to the figure 5, the electronic means 69 comprise a microprocessor 81 having inputs connected with the sensors 66, 67 and 70 and a line 82 connected, by its side, with the electronic unit 19 of the system 13. The electronic means 69 have outputs connected to the motors 60 and 61 of the mover means 56 and the electromagnets 45 and 79 through driver circuits or drivers 83, 84, 85 and 86.

The electronic means 69 are such to associate the engagement or disengagement configuration of the pinch rollers 53 and 54 to the presence of a banknote 12

revealed by the sensor 66 and/or 67 and the acquisition or issuing state of the device or the sense of movement of the stepping motors 60 and 61.

The electronic means 69 comprise a non-volatile memory 89 for selectively storing a height data associated to the height HBN of the banknotes 12 to be wound and a spacing data associated to a pre-defined free spacing GAP between two banknotes 12 to be disposed in sequence along the belt 52 and on the spool 57.

In the memory 89 are also storable the acquisition state IN or the issuing state OUT of the device 11 immediately preceding its switching off and, in an area BN, the numbers of banknotes 12 either inputting and outputting. The stored state IN and OUT and the numbers of BN remain unchanged after the switching off of the device.

Further, the electronic means 69 comprise a memory 90 in which are stored in a permanent mode data relevant to the peripheral velocity VTR of the transport rollers 31, the distance D1 between the sensor 66 and the interface zone 44 along the paths 23 and 46, and the distance D2 between the sensors 66 and 67. In the memory 90 is also stored a number of steps PWMIN, associated to a number of steps permitted to the motor 60 for further unwinding the belt 52 from the feeding roll 51, when the signal FOTO-END is revealed by the sensor 70, and accepting the banknotes 12 in transit through the system 13.

The electronic means 69 control a series of operations adapted to carry out incremental movements of the banknotes 12 along the path 46 through suitable actuations of the motors 60 and 61, which take into count the variable number of steps which are necessary for these movements and depending on the actual diameter of the spool 57 wound on the roll 50. To this end, the microprocessor 81 is programmed for carrying out the functions identified in figure 6 as time determination 92, step revealing 94, and step calculation 95.

As for the time determination function 92, the microprocessor is adapted to determine a time interval T1 necessary to a banknote 12 in transit through the sensor 66 to leave the interface zone 44 and to be taken by the rollers 53 and 54. It occurs on the basis of the data stored in 89 or in 90 and relevant to the height HBN of the banknotes 12, the velocity VTR, and the distance D2.

As for the step revealing function 94, the microprocessor 81 is adapted to reveal for each banknote 12 a number of steps PMIS executed by the motor 60, which are necessary for the passage of the trailing edge of the banknote between the sensors 66 and 67 and corresponding to the time intercurrent between the end of the signal FOTO-OUT and the end of the signal FOTO-IN. The amount PMIS is variable and depends naturally on the actual diameter of the belt and banknotes spool 57 wound on the taking-up roll 50.

As for the time calculation function 95, the microprocessor 81 stores in the memory 90 a proportionality constant K between the height data associated to the

height HBN and the spacing data associated to spacing GAP and the data relevant to the distances D1 and D2 between the interface zone 44 and the roll 50 and the sensors 66 and 67, respectively.

The microprocessor uses PMIS together with the proportionality constant K for calculating the number of steps, designated as PULT, necessary to the motor 60 for the transit of a banknote 12 beyond the sensor 67 to the end of ensuring the pre-defined spacing GAP between the trailing edge of the last acquired banknote and the front edge of the following banknote.

In the memory 90 (Fig. 5) are also stored data VIN1-VIN4 and VOUT1-VOUT4, which can be selectively recalled for obtaining different levels of angular velocities for the motors 60 and 61, associated to different diameters of the rolls 50 and 51 and identified by the revealed amounts PMIS. These levels are predisposed for limiting the variations of velocity of the belt 52, associated to the differences in the diameters of the rolls 50 and 51 dependent on the quantity of banknotes existing in the spool 57 of the roll 50.

The microprocessor 81 is also programmed for determining the void and full conditions in the roll 50, associated to the revealing of the belt end. In particular, in the acquisition phase IN revealed in the memory 89, the microprocessor 81 is adapted to forwards and backwards count the steps PW2 of the motor 61 starting from the revealing of the signal FOTO-END and to compare them with the amount PWMIN stored in the memory 90.

#### MODE OF OPERATION

The device 11 operates in a cyclic mode either for the acquisition of the banknotes and for their issuing. An issuing or an acquisition cycle of a banknote can follow indifferently to an acquisition or issuing cycle. The mode of operating of the device 11 is the following:

##### Acquisition of banknotes

In this state, the electronic unit 19 of the system 13 actuates the mechanism 21 (Figs. 1-6) to transport the banknotes 12 along the path 23 and sets the microprocessor 81 for the acquisition state. When a banknote is caught by the rollers 30, 31, it can be intercepted by the selection flap 42 driven on indications of the electronic unit 19 for entering in the selected drawer 22 along the path 46.

For a banknote moving along the path 46, the sensor 66 detects the passage of its front edge, feeding the signal FOTO-OUT for the function 92. The microprocessor 81 actuates the electromagnet 79 in the program step 91 for disengaging the roller 54 from the roller 53 and starting the counting of the feeding time Tp1 of the same banknote in the program step 93 of the function 92.

The rollers 31 transport the banknote 12 carrying the front edge beyond the pinch rollers 53 and 54

through bearing and sliding on the belt 52 which is taut between the roller 53 and the taking-up roll 50. Such sliding proceeds as long as the rollers 31 lost the catching with the same banknote 12.

This event is recognised by the microprocessor 81 through the feeding time Tp1 which reaches the amount T1. The microprocessor de-energises the electromagnet 79 in the program step 96 and, in sequence, actuates the motor 60 for a clockwise rotation for winding the belt 52 on the taking-up roll 50. The banknote 12 is taken between the belt 52 and the roller 54 by adhering on the belt 52, which is by its side pulled by the roll 50.

The microprocessor 81 actuates forwards the motor 60 to carry the banknote 12 beyond the sensor 66. With the end of the signal FOTO-OUT, the microprocessor 81 goes to the steps revealing function of the motor 60 in a program step 97. When the trailing edge of the banknote 12 leaves the revealing zone of the sensor 67, switching off FOTO-IN, the microprocessor stores in 89 the number of measured steps PMIS. Afterwards it starts the execution of the function 95 and calculates the number of steps PULT, by using PMIS and the constant K stored in 90.

Then, the following banknote will be positioned on the belt 52 to the pre-defined spacing GAP from the preceding banknote. It can be obtained either when the motor 60 is moving, and when the motor is still, in dependence on the flux of banknotes 12 at the input of the interface zone 44. At the end of the acquisition cycle, the banknote will be almost entirely wound on the roll 12.

##### Issuing of banknotes

Upon indication of the unit 19 of the system 13, the electronic means 69 provide to the issuing of the banknotes 12, by actuating the motor 61 for a rewinding rotation of the roll 51. The last acquired banknote 12 will be the first one issued. The belt 52 transports the banknote 12, by unwinding it from the roll 50 beyond the sensors 67 and 66 in the interface zone 44. Then the banknote is pinched by the transport rollers 31 and pulled away under an action prevailing on that of the belt 52.

The complete passages of the banknotes 12, as revealed by the sensor 66 are counted by the microprocessor 81 and registered in the memory 89. On the basis of the number of banknotes required by the system 13, the device 11 proceeds with their issuing as long as the issued quantity results equal to the required number.

The microprocessor 81 stops the motor 61 when the sensor 66 reveals the front edge of the banknote 12 adjacent to the last one issued. Then, the microprocessor executes a partial acquisition cycle by actuating the motor 60. The adjacent banknote is rewound almost entirely on the roll 50 and its trailing edge becomes positioned with respect to the rollers 53 and 54 such to predispose the separation space GAP from the front

edge of a banknote 12 which would be successively acquired. By this way, the device 11 is ready to proceed indifferently to a whatsoever successive acquisition or issuing operation.

#### Movement control

In accordance with the invention, the velocities of the motors 60 and 61 are selectable according to predetermined levels as function of the diameter of the belt and banknotes spool 57 wound on the taking-up roll 50 or the diameter of the spool 57 wound on the feeding roll 51.

As previously described, the indication regarding the instantaneous diameter of the rolls 50 or 51 is a function of the number of motor steps PMIS necessary to the transit of the trailing edge of a banknote 12 between the sensors 66 and 67. This information for the last acquired banknote, stored in 89, is used for controlling the movement velocity of a following banknote.

The microprocessor 81 controls the rotations of the stepping motors 60 and 61 through the driving circuits 83 and 84. For an acquisition cycle, the microprocessor 81 recalls from the memory 90 the data VIN1-VIN4 associated to the current amount PMIS for actuating the driving circuit 83 according to a commutation frequency corresponding to the recalled data. Further, the microprocessor 81 sets the driving circuit 84 for short-circuiting the windings of the motor 61, performing a braking action on this motor, such to maintain taut the bands comprised in the transport belt 52.

Likewise, in an issuing phase, the microprocessor 81 recalls from the memory 90 the VOUT1-VOUT4 data associated to the amount PMIS for actuating the driving circuit 84 according to a corresponding commutation frequency.

Further it sets the driving circuit 83 for short-circuiting the windings of the motor 60 for performing a braking action on this motor.

The banknotes 12 either inputting and outputting are revealed by the sensor 66 and counted by the microprocessor 81 on the basis of the signals FOTO-OUT. In particular, the end of the transit of the banknote 12 allows its counting. The state of presence of banknote can be requested by the system 13 in a whatsoever time and the amount BN remains stored in the non-volatile memory 89 at the switching off of the device, by means of a specific command. Reset commands and protection systems can be also provided for resetting the counter and limiting the access to the system 13 only to authorized personnel.

#### End of belt control

The microprocessor 81 recognises in the signal FOTO-END of the sensor 70 a near end state for the belt. According to whether it is recognised in the acquisition phase or in the issuing phase of the banknotes, it is representative of a full state, or a void state of the roll

50, respectively.

In particular, the opaque portion 71 adjacent to the end fixed on the roll 51 extends for such a length to allow the acquisition of other banknotes. In the case a full state condition of the roll 50 is recognised the microprocessor 81 allows the acquisition of these further banknotes, five as an example, in the current operation before disabling the device 11.

To avoid ambiguities in the meaning of the signal FOTO-END, the belt 52 is entirely wound on the roll 51 in an initialisation phase and the revealing of the opaque portion 71 is associated to the void state condition of the roll 50 and the issuing state OUT of the device 11.

The microprocessor 81 reveals also the stating of a blocking condition in the movement of the banknotes by controlling the transit times of the banknotes in front of one of the sensors 66, 67, the transit time of a front edge between the two sensors 66 and 67 and, in the issuing phase of the banknotes, the time interval between a banknote and the other or the starting of the signal FOTO-IN of the first banknote, after the issuing command.

The set conditions for the height HBN of the banknotes can be effected from the electronic unit 19 of the system 13 or by codes automatically read on the drawer 22.

#### Exemplary embodiment

In the figures 5 and 6 is illustrated a drawer 101 similar to the drawers 22 and having an acquisition and/or issuing device according to the present invention. In this device, designated as 102, the components having similar function maintain the same reference numbers of the ones of the device 11 of figure 1.

In the device 102, the taking-up roll 50 is in an advanced position towards the rollers 30-033 with respect to the feeding roller 51. In the figure 5 is shown a near void condition for the roll 50 and, in the figure 6, is shown a near full condition for the roll 50.

The lever arms 75 which support the accompanying roller 74 are part of a sustaining structure 104, fulcrumed as a bridge on the axis 43. Such structure comprises a plate 105 which is biased by a spring 106 towards the roll 50 in a clockwise sense of rotation in figure.

The lever arms 75 support rotatably also the roller 53. Further, the structure 104 supports the electromagnet 79 with the bridge 62 and the sensors 66 and 67. The path of the banknotes 12, herewith designated as 107, results variably inclined around the axis 43 between the position of minimum inclination in figure 5 for a void taking-up roll 50, and the position of maximum inclination in figure 6 for a full roll 50.

The device 102 is controlled by the already described electronic means 69 and its mode of operation is completely similar to the one of the device 11. In fact, the variations of inclination of the path 107 do not modify the cinematic conditions of the various compo-

nents. The device 102 results of limited dimensions and presents a path 107 for the banknotes 12 short and directed.

Naturally, the principle of the invention remaining the same, the embodiments and the details of construction can be widely varied with respect to what has been described and illustrated, by way of non-limitative example, without by this departing from the ambit of the present invention.

### Claims

1. An acquisition and/or issuing device (11) for banknotes (12) or other flexible documents comprising a taking-up roll (50), a feeding roll (51), at least a transport belt (52) susceptible of winding and unwinding between said rolls (50, 51) and a pair of pinch rollers (53, 54), said taking-up roll (50) being adapted to store the banknotes (12) in a spool (57) together with the said belt (52), characterised in that the pinch rollers (53, 54) are reciprocally moveable between an engagement configuration for the banknotes on the transport belt (52) and a disengagement configuration, said device (11) comprising

first and second sensor means (66, 67) disposed in a path (46) for the banknotes (12), for providing relevant presence information (FOTO-IN, FOTO-OUT);

actuating means (68) for the engagement and disengagement configuration of the pinch rollers (53, 54); and

electronic means (69) for controlling the actuating means (68) and the rotation of the taking-up and feeding rolls (50, 51), by associating the engagement and disengagement configurations to the presence information of a banknote (12) from the first (66) and/or the second (67) sensor means.

2. An acquisition and/or issuing device according to Claim 1, characterised in that the said pinch rollers (53, 54) are disposed along the path (46) for the banknotes (12) included between an interface zone (44) and in which the said first and second sensor means (66, 67) are disposed between the said interface zone (44) and said pair of rollers (53, 54) and the pair of rollers (53, 54) and the taking-up roll (50), respectively.
3. An acquisition and/or issuing device according to Claim 1 or 2, characterised in that the banknotes (12) are available from the taking-up roll (50) in manner to be spaced one from another through a pre-defined free spacing (GAP) and in which said electronic means (69) condition the operation of the

said actuating means (68) for performing the said pre-defined spacing (GAP).

4. An acquisition and/or issuing device for banknotes according to Claim 3, characterised in that the said taking-up and feeding rolls (50, 51) are driven by stepping motors (60, 61) and in that the said electronic means (69) determine the number of steps (PWMIN, PMIS, PULT, PW2) associated to each banknote (12) in response to the presence information (FOTO-OUT, FOTO-IN) of the said sensor means (66, 67) and the height (HBN) of the said banknotes (12), the said electronic means (69) being adapted to store banknote steps (PMIS) associated to the passage of a banknote (12) and comprising processing means for determining the number of spacing steps (PULT) necessary to space a banknote (12) from a following one proportionally to the rate between the said spacing (GAP) and the height (HBN) of the banknote (12).

5. An acquisition and/or issuing device for banknotes or other flexible documents, comprising a taking-up roll (50), a feeding roll (51), at least a transport belt (52) susceptible of winding and unwinding between the feeding roll (51) and the taking-up roll (50) and a pair of pinch rollers (53, 54), and in which the taking-up roll (50) is adapted to store in a spool (57) the banknotes (12) together with the transport belt (52), characterised in that the taking-up and feeding rolls (50, 51) are rotatable on fixed axes, the said device (11) comprising

an accompanying roller (74) susceptible of movement perpendicularly to its axes between the feeding roll (51) and the taking-up roll (50) for maintaining the banknotes (12) adherent to the transport belt (52) on the taking-up roll (50);

a sustaining structure (1054) common to said pair of pinch rollers (53, 54) and said accompanying roller (74) and susceptible of oscillation to follow the variations of diameter in said taking-up roll (50); and

pressure means (105, 106) for maintaining said accompanying roller (74) in pressure engagement with the transport belt (52) in a tangency zone with the said taking-up roll (50).

6. An acquisition and/or issuing device according to the Claim 5, characterised in that the axes of the taking-up and feeding rolls (50, 51) are disposed at different heights and the said pinch rollers (53, 54) are disposed at a side of the said taking-up and feeding rolls and an intermediate height between the axes of the said rolls, the said pinch rollers (53, 54) being susceptible of reciprocal movement between a pressure engagement configuration for



the banknotes (12) on the transport belt (52) and a disengagement configuration, and in which said device (11) further comprises first and second sensors (66, 67) disposed in the path (46) for the banknotes (12), before the pinch rollers and between the pinch rollers (53, 54) and the taking-up roll (50), respectively; and actuating means (68) for the engagement and disengagement configuration of the said pair of pinch rollers (53, 54), the said actuating means (68) comprising an electromagnet (79) mounted on said structure (104) susceptible of oscillation and actuatable in dependence on the said first and second sensing means (66, 67).

7. An acquisition and/or issuing device for banknotes or other flexible documents, comprising a taking-up roll (50), a feeding roll (51), at least a transport belt (52) susceptible of winding and unwinding between said rolls (50, 51) and a pair of pinch rollers (53, 54), said taking-up roll (50) being adapted to store in a spool (57) the banknotes (12) together with said belt (52), the said device being characterised in that it comprises

stepping motors (60, 61) for putting in rotation the said taking-up roll (50) and feeding roll (51);

sensing means (66, 67) disposed in the path (46) of the banknotes (12) for revealing the passage of a banknote (12) through a given revealing zone; and

electronic means (69) for controlling said stepping motors (60, 61), the said electronic means including

counting means (81, 92, 94) conditioned by the said sensing means (66, 67) for revealing a number of reference steps (PMIS) of one (60) of the said motors (60, 61) associated to the passage of a banknote (12) of pre-defined height (HBN), and

means conditioned by the said counting means for defining steps (PULT) of the said one motor (60) associated to the movement of a following banknote (12).

8. An acquisition and/or issuing device for banknotes according to Claim 7, characterised in that said electronic means (69) comprise memory means (90) in which are stored data associated to predetermined angular velocities (VIN1-VIN4) of the said stepping motors (60, 61) and in which circuit means (81) are provided for associating said reference number (PMIS) to one of the said stored data (VIN1-VIN4) for limiting the variations of velocity of the banknotes (12) due to different quantities of banknotes wound on the taking-up roll (50).

9. An acquisition and/or issuing device for banknotes, comprising a plurality of lodgements (20), each one adapted to accommodate a corresponding drawer (22) for storing banknotes (12), characterised by a safe (14) in which are defined said lodgements (20) to be laid one upon the other for accommodating said drawers (22) according to two columns, the said safe (14) including a transport mechanism (21) for moving the banknotes (12) along a predetermined path (46) between the said lodgements (20) and in which said mechanism (21) comprises

a toothed belt (25) localised between the columns of the drawers and in which each drawer (22) is susceptible of movement in a lodgement (20) with respect to the said belt (25),

each drawer (22) comprising a toothed pulley (34) adapted to cooperate with the said belt (25) for taking the movement therefrom when it is in an engagement condition, and transport rollers (31; 30, 32) adapted to be put in rotation from the said toothed pulley (34), and in which means (42) are provided for deviating the banknotes (12) moved by the said transport mechanism (21).

10. An acquisition and/or issuing device for banknotes according to Claim 9, characterised in that the toothed belt (25) includes teeth on an inner and an outer surface and in which the said pulley of a given drawer (22) is adapted to engage with the teeth of the toothed belt (25) disposed on the said outer surface or the said inner surface, in dependence on the column on which is disposed the said given drawer (22).



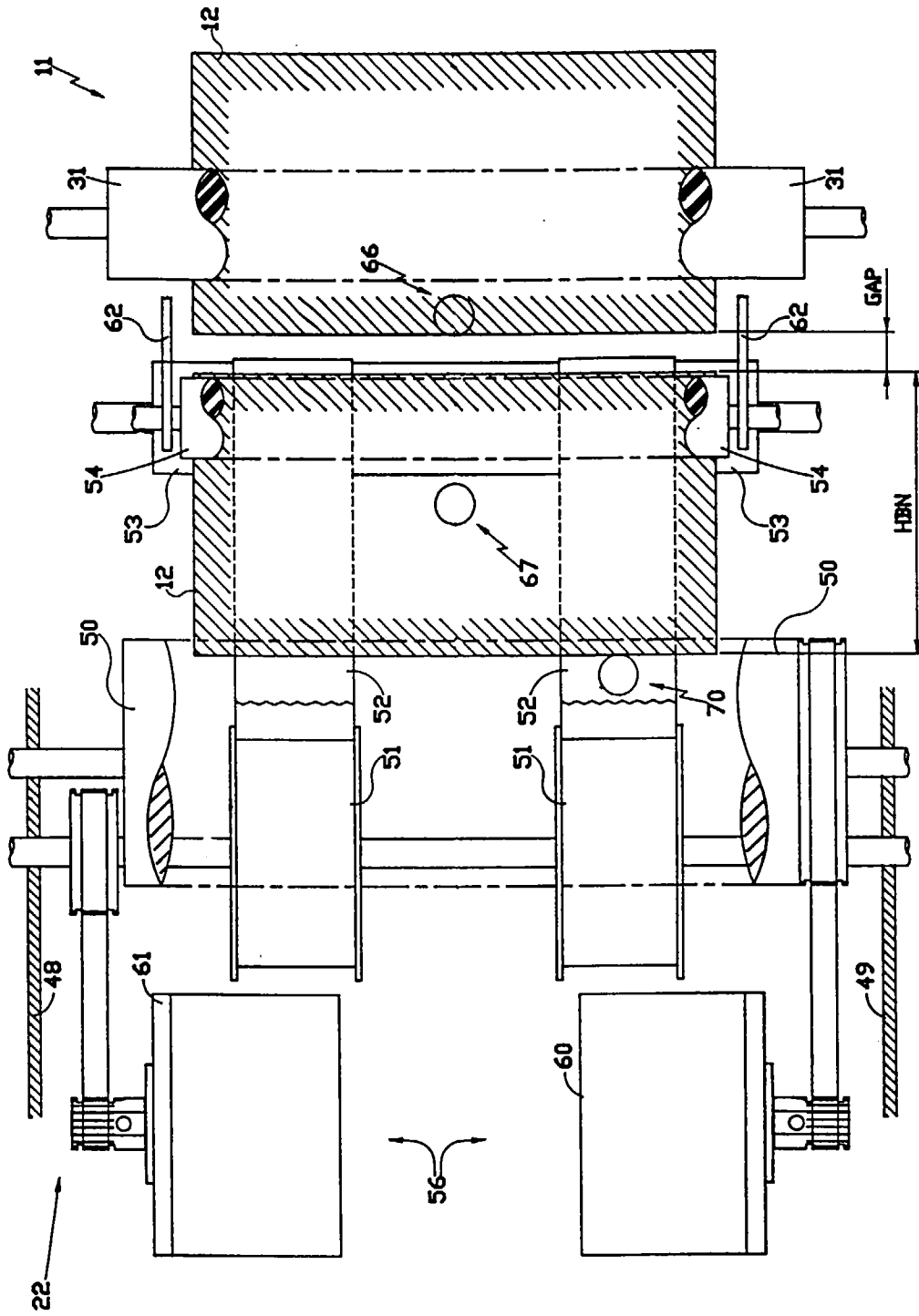

FIG. 2

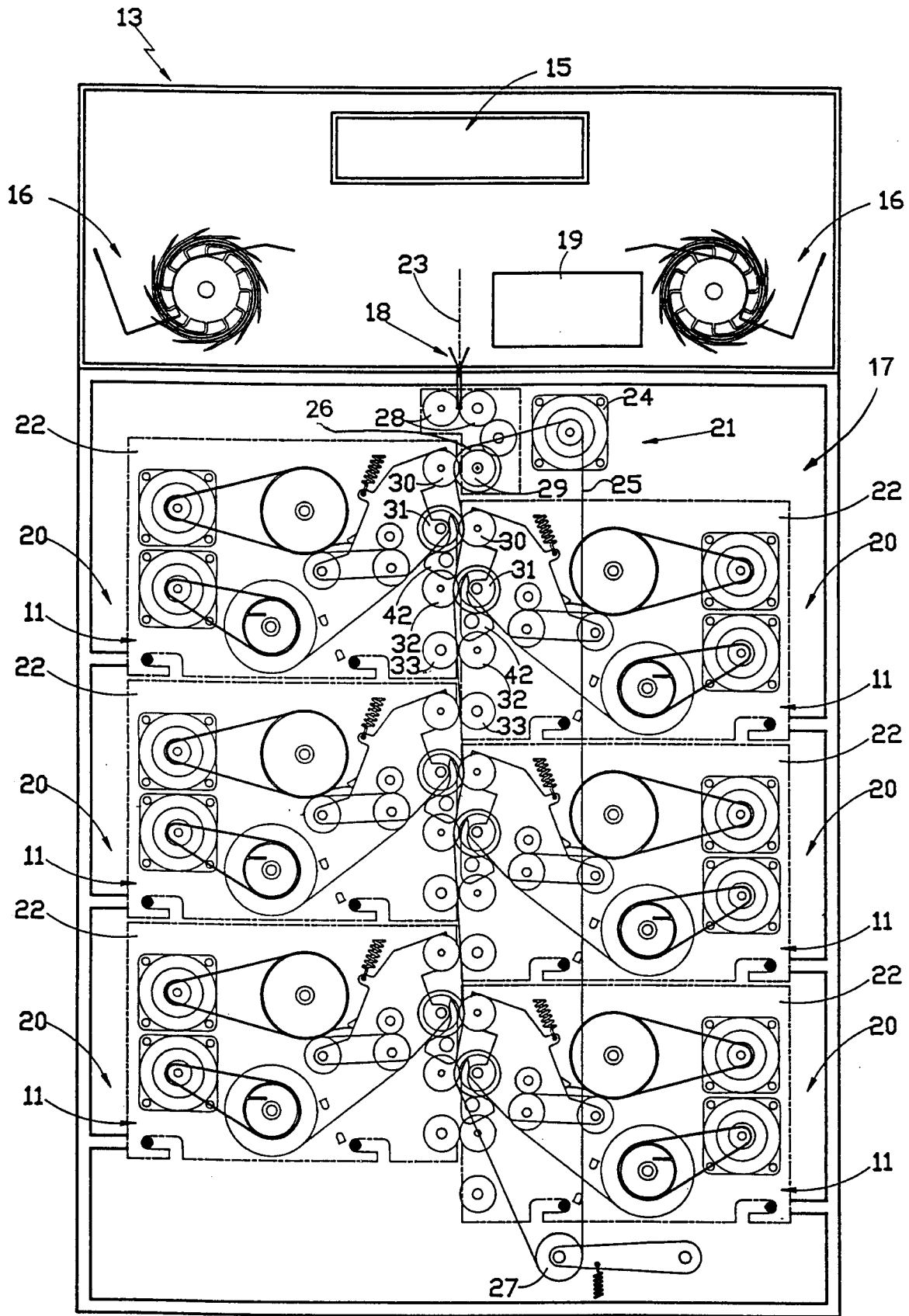

FIG. 3

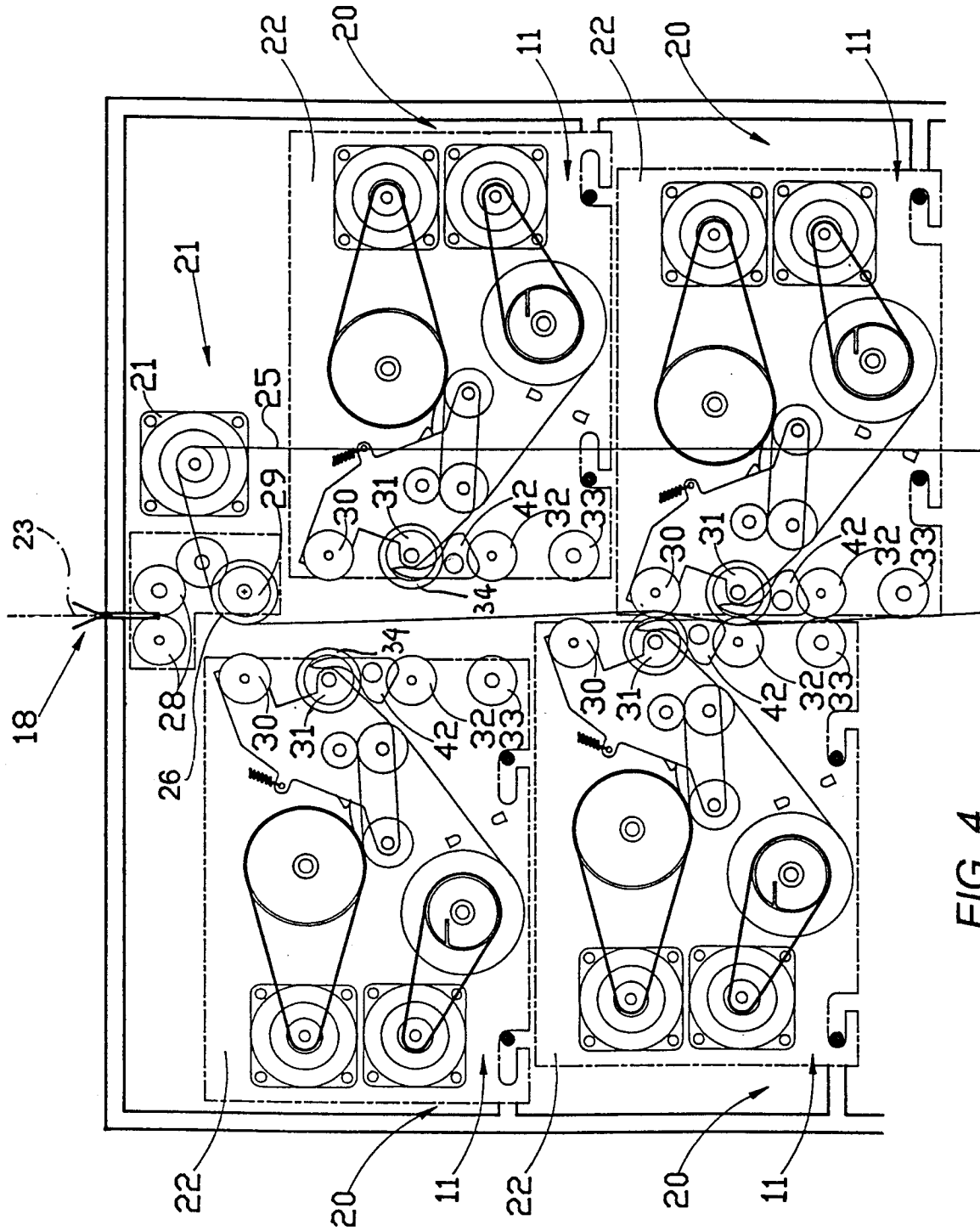

FIG. 4

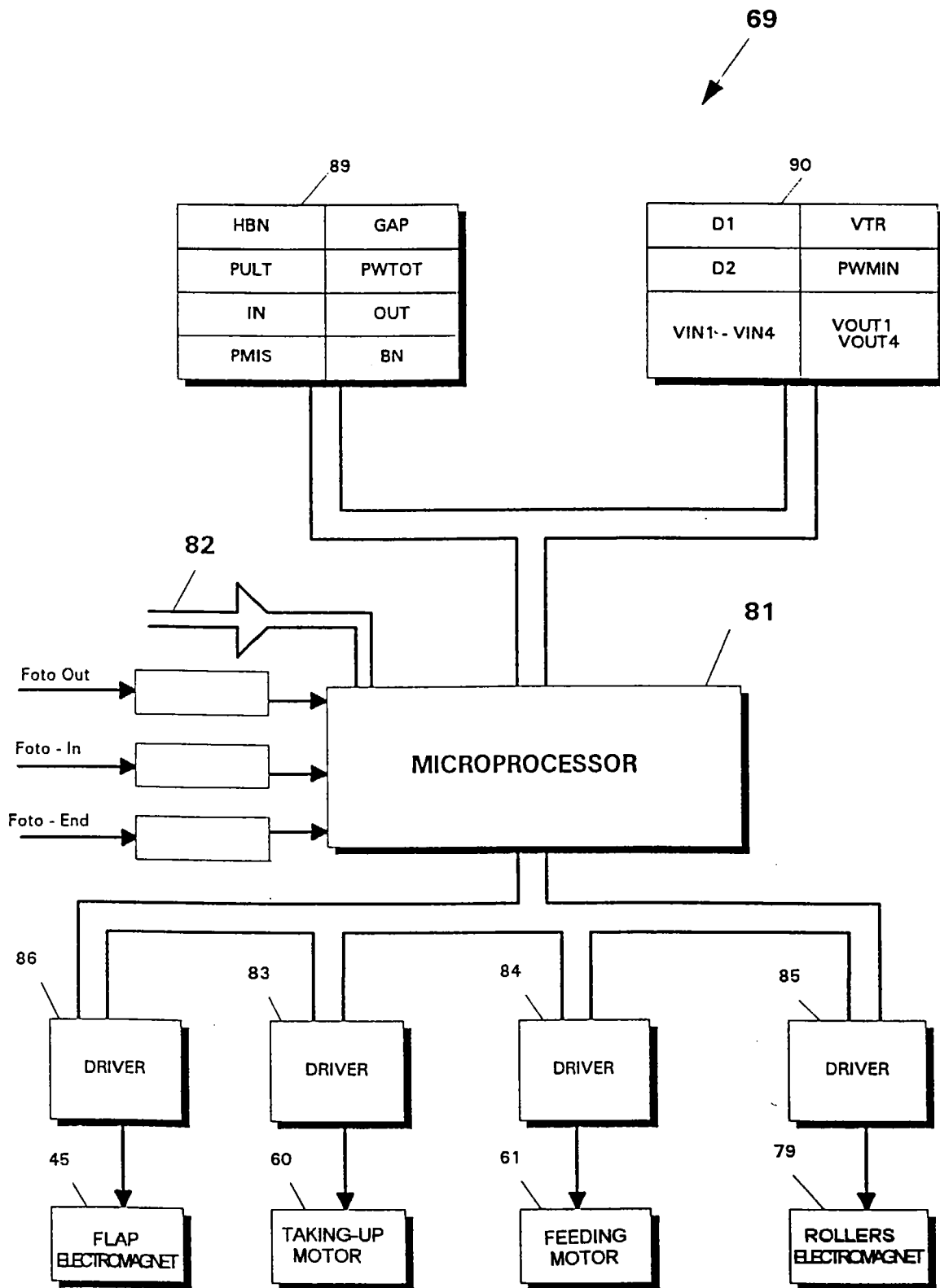

FIG. 5

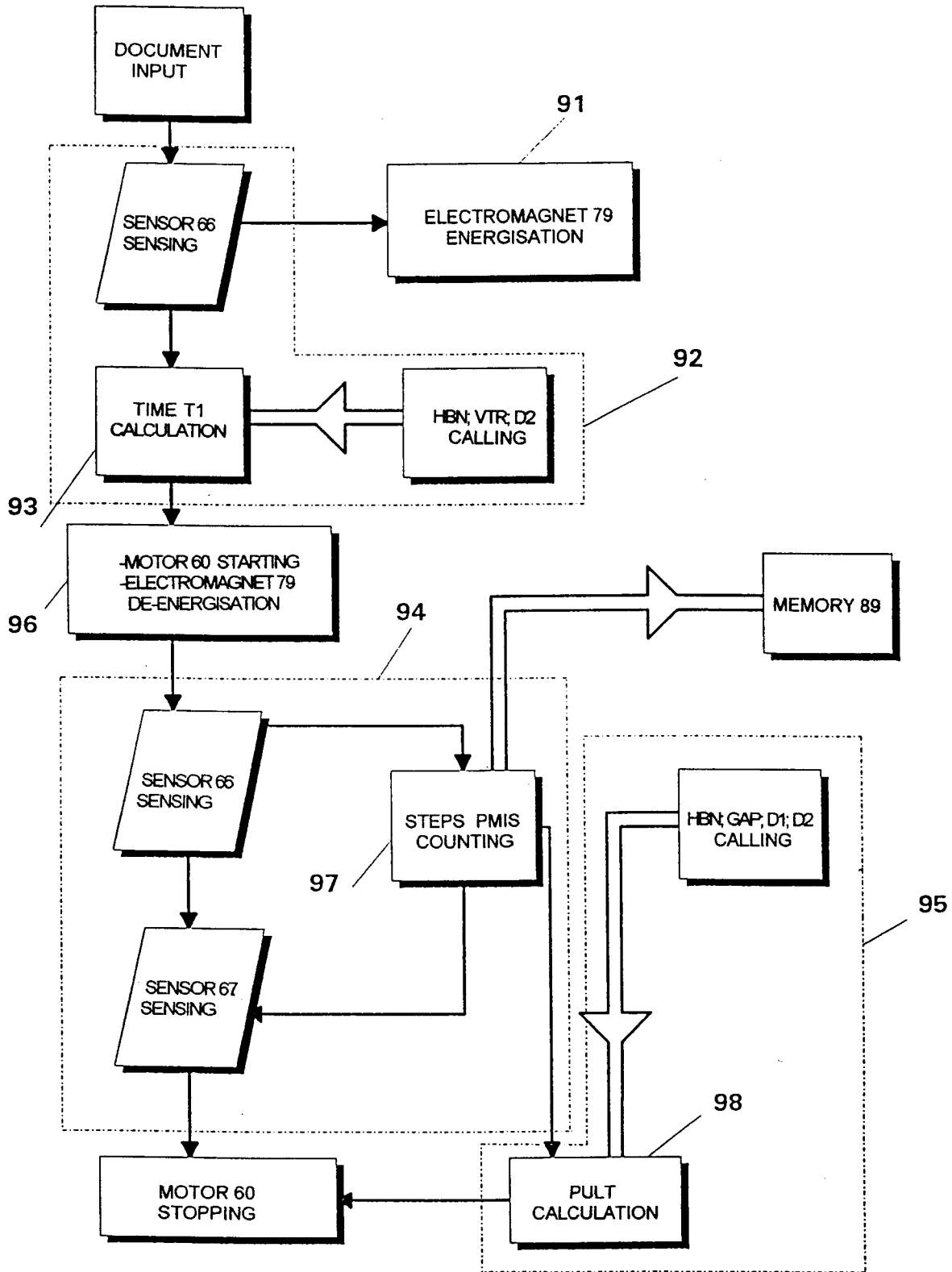

FIG. 6

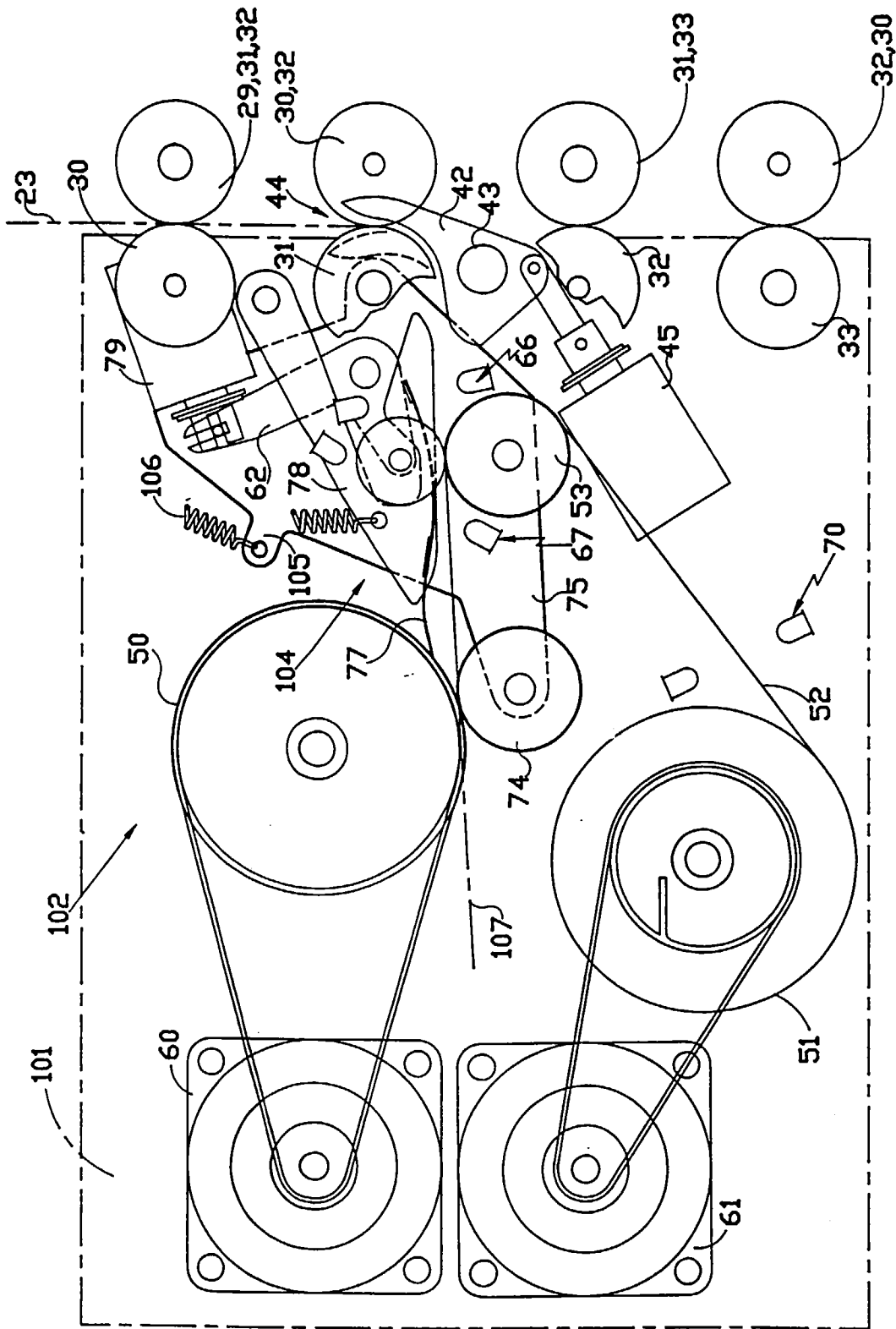

FIG. 7



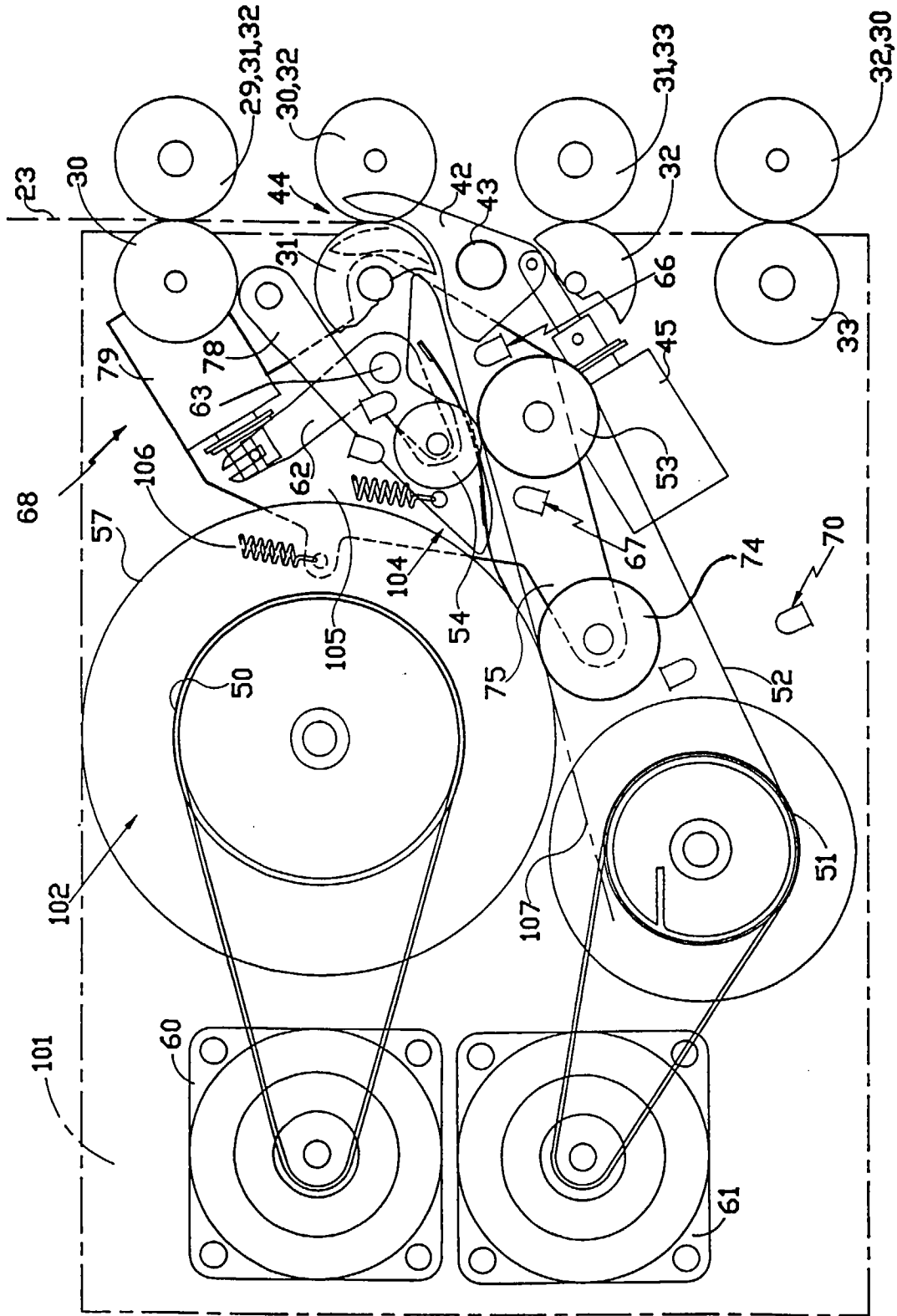

FIG. 8