



Europäisches Patentamt  
European Patent Office  
Office européen des brevets



(11) **EP 0 795 877 B1**

(12) **EUROPEAN PATENT SPECIFICATION**

(45) Date of publication and mention  
of the grant of the patent:  
**05.12.2001 Bulletin 2001/49**

(51) Int Cl.7: **H01B 17/26**

(21) Application number: **97103464.0**

(22) Date of filing: **03.03.1997**

(54) **DC bushing**

Gleichstromdurchführung  
Traversée à courant continu

(84) Designated Contracting States:  
**DE SE**

(30) Priority: **14.03.1996 JP 5759096**

(43) Date of publication of application:  
**17.09.1997 Bulletin 1997/38**

(73) Proprietors:  
• **Hitachi, Ltd.**  
**Chiyoda-ku, Tokyo 101 (JP)**  
• **The Kansai Electric Power Co., Inc.**  
**Kita-ku, Osaka (JP)**  
• **SHIKOKU ELECTRIC POWER CO., INC.**  
**Kagawa-ken 760 (JP)**  
• **ELECTRIC POWER DEVELOPMENT CO., LTD**  
**Tokyo 104 (JP)**

(72) Inventors:  
• **Kashiwakura, Masaru**  
**Hitachi-shi (JP)**  
• **Sekine, Kazuo**  
**Hitachi-shi (JP)**

• **Obata, Toshimitsu**  
**Hitachi-shi (JP)**  
• **Kojima, Hiroaki**  
**Hitachi-shi (JP)**  
• **Tanaka, Makoto**  
**Itami-shi (JP)**  
• **Sugihara, Hiroshi**  
**Anan-shi (JP)**  
• **Hatano, Masayuki**  
**Tokyo (JP)**

(74) Representative: **Strehl Schübel-Hopf & Partner**  
**Maximilianstrasse 54**  
**80538 München (DE)**

(56) References cited:  
**EP-A- 0 285 895**

• **PATENT ABSTRACTS OF JAPAN vol. 5, no. 149**  
**(E-075), 19 September 1981 & JP 56 081909 A**  
**(HITACHI), 4 July 1981**

**EP 0 795 877 B1**

Note: Within nine months from the publication of the mention of the grant of the European patent, any person may give notice to the European Patent Office of opposition to the European patent granted. Notice of opposition shall be filed in a written reasoned statement. It shall not be deemed to have been filed until the opposition fee has been paid. (Art. 99(1) European Patent Convention).

## Description

### BACKGROUND OF THE INVENTION

#### Field of the Invention

**[0001]** The present invention relates generally to a DC bushing employed in an electric power transmission system. More particularly, the invention is concerned with an improved structure of a DC bushing equipped with a shield barrier enclosing a lower insulated shield disposed at a lower portion of the DC bushing.

#### Description of the Related Art

**[0002]** Not only in Japan but also in other countries, electric energy demand goes on increasing steadily, which is accompanied with a trend of developing an extended scale of high-rated transmission system as well as complexity or intricacy in the system configuration. Further, in view of the situations which the electric energy enterprises have been confronting in recent years, the power generation plants tend to be installed at locations remote from the areas where the consumers are resident. Besides, the scale of the transmission system is increasing. Such being the circumstances, there are required stability and reliability of the transmission system inclusive of stability of voltage, enhanced short-circuit capacity and so forth. To this end, a DC (Direct Current) power transmission is considered as a means which can promise effective solution meeting the requirements mentioned above. In this conjunction, structuring of a DC transmission system rated 500 kV (hereinafter also referred to as the DC-500 kV transmission system) is being planned. For realization of such DC-500 kV transmission system, DC bushings for DC apparatuses and machines are indispensable.

**[0003]** Figure 1 of the accompanying drawings shows a DC bushing in the state mounted in transformer equipment. Referring to the figure, in the transformer equipment provided in a transmission line, a transformer 20 composed of a core 21 and a coil 22 is disposed within a tank 11 which is filled with an insulating oil 23. In such transformer equipment, a DC bushing 24 is employed for insulating an output or input line of the transformer 20 from the tank 11.

**[0004]** In conjunction with DC insulation, it is noted that distribution of the electric field as making appearance is determined primarily by voltage apportionment which in turn is determined by resistivities of the insulating oil and oil-impregnated paper. Accordingly, for realization of the satisfactory DC insulation, it is required in addition to the insulation techniques adopted heretofore in the insulation for AC apparatuses and/or instruments that the dielectric strength of a solid insulation member such as the oil-impregnated paper having higher resistivity as compared with the insulating oil has to be increased.

**[0005]** Under the circumstances, there has been proposed such an insulation structure as shown in Fig. 2 of the accompanying drawings. More specifically, Fig. 2 shows an insulation structure disclosed in JP-A-56-81909. Referring to the figure, a porcelain tube 1 supported in a tank 11 filled with insulating oil is provided with a barrier 6 at a lower portion of the porcelain tube 1, the barrier 6 being formed by oil-impregnated paper, wherein a shielding electrode 3 which is so disposed as to enclose a metal flange 10 mounted at a bottom end of the porcelain tube 1 is covered with an insulating cover or layer 4 formed of oil-impregnated paper to realize a lower insulated shield 5. With the insulation structure described above, voltage as applied is apportioned among the solid insulators with the DC dielectric strength being thus enhanced. Generally, in the case of a solid insulator formed by radially laminated oil-impregnated paper layers, a breakdown electric field of high intensity makes appearance in the direction thickness-wise of the oil-impregnated paper layers. Thus, in order to prevent the dielectric breakdown from occurring, starting from the conductor 2 and the lower insulated shield 5, outer peripheries of these portions are enclosed by a pulp-molded shield barrier 8 formed of oil-impregnated paper, while an oil gap 7 is provided between the shield barrier 8 and the lower insulated shield 5 for allowing the insulating oil to flow through the oil gap 7.

**[0006]** In the conventional DC bushing known heretofore, a mineral oil is used as the insulating oil, while the solid insulator is formed of kraft paper or pressboard impregnated with mineral oil. In this conjunction, it is noted that volume resistivity of the mineral oil is lower than that of the oil-impregnated paper by one order of magnitude. Consequently, when a DC voltage is applied, a major proportion of the voltage will be borne by the oil-impregnated paper forming the insulating cover 4 of the lower insulated shield 5, resulting in that the electric field which is higher by one order of the electric field appearing in the oil gap 7 acts on the oil-impregnated paper layer. Besides, due to structural or geometrical factors, the electric field appearing at an upper end portion of the lower insulated shield 5 immersed in the oil exhibits highest intensity. For these reasons, the insulation certainly can be ensured for the DC voltage of 250 kV with the structure of the conventional DC bushing described above. However, when DC voltage of 500 kV is applied, dielectric breakdown may take place, starting from the upper end portion of the lower insulated shield 5.

### SUMMARY OF THE INVENTION

**[0007]** In the light of the state of the art described above, it is an object of the present invention to provide a DC bushing which can ensure an increased DC dielectric strength in the vicinity of the lower insulated shield and which can thus assure improved reliability of the DC bushing.

**[0008]** This object is solved by a bushing as set forth in claim 1 or 2. The subclaims are directed to preferred embodiments of the invention.

**[0009]** The invention is directed to a DC bushing which is comprised of a porcelain tube constituting a lower portion of the DC bushing and immersed in an insulating oil contained in a tank, a lower insulated shield provided at a lower end portion of the porcelain tube and including a shielding electrode covered with an insulating cover, and a shield barrier disposed around an outer periphery of the lower insulated shield with an oil gap being defined between the shield barrier and the lower insulated shield.

**[0010]** In the DC bushing of the structure described above, it is taught according to a first aspect of the present invention to realize the shield barrier with a thickness which is greater than a width of the aforementioned oil gap as viewed in a direction widthwise of the oil gap.

**[0011]** Further, according to another aspect of the invention, it is taught to form the shield barrier by using a solid insulator which exhibits a higher volume resistivity than that of the oil-impregnated paper.

**[0012]** Preferably, the shield barrier has a structure that upon application of a DC voltage, a proportion of the DC voltage to be borne by the shield barrier is larger than 15 % inclusive.

**[0013]** The above and other objects, features and attendant advantages of the present invention will more easily be understood by reading the following description of the preferred embodiments thereof taken, only by way of example, in conjunction with the accompanying drawings.

#### BRIEF DESCRIPTION OF THE DRAWINGS

**[0014]** In the course of the description which follows, reference is made to the drawings, in which:

Fig. 1 is a view showing schematically an apparatus in which a DC bushing known heretofore is mounted;

Fig. 2 is a sectional view showing a DC bushing known heretofore;

Fig. 3 is a sectional view showing a DC bushing according to an exemplary embodiment of the present invention;

Fig. 4 is a fragmentary enlarged sectional view showing a major portion of the conventional DC bushing together with a map of electric field making appearance upon application of a DC voltage;

Fig. 5 is a fragmentary enlarged sectional view showing a major portion of the DC bushing shown in Fig. 3 together with a map of electric field making appearance upon application of a DC voltage; and Fig. 6 is a sectional view showing a DC bushing according to another exemplary embodiment of the invention.

#### DESCRIPTION OF THE PREFERRED EMBODIMENTS

**[0015]** Now, the present invention will be described in detail in conjunction with what is presently considered as preferred or typical embodiments thereof, by referring to the drawings. In the following description, like reference characters designate like or corresponding parts throughout the several views. Also in the following description, it is to be understood that such terms as "upper", "lower", "top", "bottom" and the like are words of convenience and are not to be construed as limiting terms.

**[0016]** Figure 3 is a sectional view showing a DC bushing which is designed for use in an electric power transmission system rated DC 500 kV according to an exemplary embodiment of the invention.

**[0017]** Referring to Fig. 3, a DC bushing 24 is fixedly mounted in a tank 11 which is filled with an insulating oil, wherein a conductor 2 is secured to a bottom portion of a porcelain tube 1 of the DC bushing 24 by using a metal flange 10. A lower insulated shield 5 is provided in such disposition that outer peripheral portions of the metal flange 10 and the conductor 2 are enclosed by the lower insulated shield 5. To this end, the lower insulated shield 5 is composed of a shielding electrode 3 and an insulating cover 4 formed by winding oil-impregnated crepe paper around the shielding electrode 3. A barrier 6 formed of crepe paper is mounted at a lower portion of the porcelain tube 1 in such disposition as to close a gap formed between the porcelain tube 1 and the lower insulated shield 5. Further, a shield barrier 8 made of oil-impregnated paper and serving as a solid insulator is so disposed as to cover a lower end portion of the barrier 6 and an outer peripheral portion of the lower insulated shield 5, wherein an oil gap is defined between the shield barrier 8 and the lower insulated shield 5 for allowing the insulating oil to move through the oil gap 7.

**[0018]** Figure 5 is a fragmentary enlarged sectional view showing a major portion of the DC bushing together with a map of electric field which makes appearance in a top end portion of the lower insulated shield 5 and the shield barrier 8 disposed in opposition to the lower insulated shield 5, when a DC voltage of 500 kV is applied to the conductor 2.

**[0019]** As can be seen in Fig. 5, the shield barrier 8 has a thickness  $W_2$  which is greater than a width  $W_1$  of the oil gap 7 defined between the lower insulated shield 5 and the shield barrier 8 disposed in opposition to the lower insulated shield 5, as viewed in the direction widthwise of the oil gap 7. For the purpose of comparison, Fig. 4 shows a map of electric field making appearance in the conventional DC bushing shown in Fig. 2. As can be seen in Fig. 4, in the case of the DC bushing known heretofore, the thickness  $W_3$  of the shield barrier 8 is smaller than the width  $W_1$  of the oil gap 7 defined between the lower insulated shield 5 and the shield barrier 8 for some reasons from the standpoint of manufactur-

ing. More specifically, the shield barrier 8 is provided intrinsically for the purpose of preventing the dielectric breakdown which may occur, starting from the lower insulated shield 5 and the conductor 2, and it has heretofore been believed that there is no necessity of increasing the thickness of the shield barrier 8 because of higher intensity of the electric field in the solid insulator as viewed in the direction perpendicularly to the layers of the solid insulator. However, when the thickness W2 of the shield barrier 8 is increased, as described above, a portion of the voltage which is to be borne by the barrier 6 in the case of the conventional DC bushing (see Fig. 4) is transferred to the shield barrier 8, as can be seen from Fig. 5, as a result of which the intensity of the electric field internally of the barrier 6 and the insulating cover 4 is correspondingly mitigated, whereby the dielectric strength of the DC bushing as a whole can be enhanced.

**[0020]** Parenthetically, it has experimentally been established that when the shield barrier 8 is formed in a thickness W2 of 25 mm which is larger than the width of the oil gap and when the DC voltage of 500 kV is applied to the conductor 2, the proportion of the voltage appearing across the insulating cover 4 of the lower insulated shield 5 (i.e., the proportion of the voltage to be borne by the insulating cover 4) is 66 % while that of the shield barrier 8 is 34 %. By contrast, when a DC voltage of 500 kV is applied to the conductor 2 of the conventional DC bushing shown in Fig. 4 in which the thickness W3 of the shield barrier 8 is 5 mm, proportion of the voltage to be borne by the insulating cover 4 of the lower insulated shield 5 amounts as high as 92 %, whereas proportion of the voltage to be borne by the shield barrier 8 is 8 %. From the comparison of these experimental demonstrations, it will readily be understood that by virtue of the structure of the DC bushing according to the invention, the intensity of electric field making appearance in the insulating cover 4 can significantly be mitigated or reduced. Thus, according to the teaching of the invention incarnated in the embodiment illustrated in Figs. 3 and 5, there can be realized a DC bushing which ensures increased dielectric strength and hence a high reliability of the bushing for use in the DC transmission applications.

**[0021]** Figure 6 is a sectional view showing a DC bushing designed for use in a DC-500-kV transmission system according to another embodiment of the invention.

**[0022]** The DC bushing shown in Fig. 6 differs from the structure shown in Fig. 3 in respect to the material and the thickness of the shield barrier. More specifically, in the DC bushing according to the instant embodiment of the invention now under consideration, the shield barrier designated by reference numeral 9 is formed of a solid insulator having a higher volume resistivity than that of the oil-impregnated paper with the thickness of the shield barrier 9 being held substantially same as that of the shield barrier 8 employed in the conventional DC bushing. Except for these differences, the DC bushing

according to the instant embodiment of the invention is substantially same as the conventional one. Accordingly, components same as or equivalent to those of the DC bushing shown in Fig. 3 are designated by like reference characters and repeated description thereof is omitted.

**[0023]** In the case of the DC bushing shown in Fig. 6, the insulating cover 4 is formed of oil-impregnated paper such as kraft paper, pressboard or the like which has a volume resistivity ranging from of  $10^{15}$  to  $10^{16}$   $\Omega\text{cm}$ . In the DC bushing now of concern, the shield barrier 9 is formed of an insulation material having the volume resistivity which is higher than that of the oil-impregnated paper by one order of magnitude. As the preferred insulation material for forming the shield barrier 9, there may be mentioned engineering plastic materials such as, for example, PET (polyethylene terephthalate), PTFE (polytetrafluoride ethylene), PPO (polyphenylene oxide), PPS (polyphenylene sulfide), PMP (polymethylene pentene), PE (polyethylene) and the like. The shield barrier 9 may be formed by molding a sheet of the material mentioned above or by winding a film of the material mentioned above. The materials enumerated above have specific inductive capacities falling within a range of "2" to "3". In other words, the dielectric constant of these materials is lower than that of the oil-impregnated paper and can not give rise to concentration of the electric field in the oil gap even when an AC voltage is applied to the conductor 2. For these reasons, the materials mentioned above is preferred for forming the shield barrier 9.

**[0024]** With the structure of the DC bushing described above, the proportion of the voltage borne by the shield barrier 9 upon application of DC voltage to the conductor 2 is greater than that to be borne by the shield barrier of the conventional DC bushing. Thus, the intensity of the electric field appearing in the insulating cover 4 can be mitigated, whereby the DC dielectric strength of the DC bushing can be improved with the reliability thereof being enhanced.

**[0025]** In this conjunction, it has experimentally been established that when the shield barrier 9 is formed of PTFE having highest volume resistivity in a thickness of 5 mm which is substantially equal to the width of the oil gap 7 and when the DC voltage of 500 kV is applied to the conductor 2, the proportion of the voltage appearing across the insulating cover 4 of the lower insulated shield 5 (i.e., the proportion of the voltage to be borne by the insulating cover 4) is 76 % while that of the shield barrier 9 is 24 %.

**[0026]** In the case of the DC bushing shown in Fig. 3, the thickness W3 of the shield barrier 8 is selected to be greater than the width W1 of the oil gap 7 formed between the shield barrier 8 and the lower insulated shield 5, while in the DC bushing shown in Fig. 6, the shield barrier 9 is formed of a solid insulator having a higher volume resistivity than that of the oil-impregnated paper, to thereby realize reduction of the proportion of voltage

to be borne by the insulating cover 4. However, the thickness and/or material of the shield barrier may be determined reversely on the basis of predetermined proportion of voltage to be borne by the shield barrier. In this conjunction, experiment conducted by the inventors of the present application has shown that unless the proportion of voltage to be borne by the shield barrier is greater than 15 % inclusive thereof, the electric field appearing in the barrier 6 in the direction along the layers in the vicinity of the top end portion of the lower insulated shield 5 as well as the in-oil electric field appearing in the lower end portion of the lower insulated shield 5 becomes high to incur dielectric breakdown. The proportion of voltage to be borne by the shield barrier which is greater than 15 % inclusive can easily be realized by increasing the thickness of the shield barrier and/or forming it of a material having a large volume resistivity. **[0027]** In the foregoing description, it has been assumed that in the DC bushing shown in Fig. 3, the shield barrier 8 is formed of oil-impregnated paper. However, it goes without saying that when the insulation material of high volume resistivity such as PET or the like as adopted in the DC bushing shown in Fig. 6 is employed for implementing the shield barrier 8 shown in Fig. 3, the dielectric strength can further be enhanced.

**[0028]** Besides, in both of the DC bushings shown in Figs. 3 and 6, respectively, the proportion of the voltage to be borne by the shield barrier 8 and hence the DC dielectric strength of the DC bushing on the whole can further be increased by decreasing the width of the oil gap within a range where convection of the insulating oil for heat dissipation is not interfered.

**[0029]** As can be appreciated from the foregoing, in the DC bushings according to the invention, the proportion of voltage to be borne by the insulating cover of the lower insulated shield can be reduced by selecting the thickness of the shield barrier to be greater than the width of the oil gap as viewed in the direction widthwise thereof and/or by forming the shield barrier of a solid insulator having a higher volume resistivity than that of oil-impregnated paper, preferably by realizing the shield barrier in such a structure that upon application of a DC voltage, the proportion of the DC voltage to be borne by the shield barrier is higher than 15 % inclusive. With the structures of the DC bushing according to the invention, the DC dielectric strength in the vicinity of the lower insulated shield can significantly be improved to assure high reliability of the DC bushing.

## Claims

### 1. A DC bushing (24), comprising:

a porcelain tube (1) constituting a lower portion of said DC bushing (24) and immersed in insulating oil (23) contained in a tank (11);  
a lower insulated shield (5) provided at a lower

end portion of said porcelain tube (1) and including a shielding electrode (3) covered with an insulating cover (4); and  
a shield barrier (8) disposed around an outer periphery of said lower insulated shield (5) with an oil gap (7) defined between said shield barrier (8) and said lower insulated shield (5),

**characterised in that** said shield barrier (8) is realized with a thickness (W2) which is greater than a width (W1) of said oil gap (7) as viewed in a direction widthwise of said oil gap (7).

### 2. A DC bushing (24), comprising:

a porcelain tube (1) constituting a lower portion of said DC bushing (24) and immersed in an insulating oil (23) contained in a tank (11);  
a lower insulated shield (5) provided at a lower end portion of said porcelain tube (1) and including a shielding electrode (3) covered with an insulating cover (4); and  
a shield barrier (9) disposed around an outer periphery of said lower insulated shield (5) with an oil gap (7) defined between said shield barrier (9) and said lower insulated shield (5),

**characterised in that** said shield barrier (9) is formed of a solid insulator having a higher volume resistivity than oil-impregnated paper.

### 3. A DC bushing according to claim 2,

wherein said shield barrier (9) is realized with a thickness (W2) which is greater than a width (W1) of said oil gap (7) as viewed in a direction widthwise of said oil gap (7).

## Patentansprüche

### 1. Gleichstrom-Durchführung (24), aufweisend:

eine einen unteren Abschnitt der Gleichstrom-Durchführung (24) bildende Porzellanröhre (1), die in isolierendes Öl (23) getaucht ist, das in einem Tank (11) enthalten ist,  
eine an einem unteren Endabschnitt der Porzellanröhre (1) vorgesehene isolierte untere Abschirmung (5), die eine Abschirmelektrode (3) beinhaltet, die von einer isolierenden Abdeckung (4) bedeckt ist, und  
eine Abschirmbarriere (8), die um den äußeren Umfang der isolierten unteren Abschirmung (5) herum angeordnet ist, so daß zwischen der Abschirmbarriere (8) und der isolierten unteren Abschirmung (5) ein Ölspalt (7) besteht,

**dadurch gekennzeichnet, daß**

die Abschirmbarriere (8) eine Dicke (W2) aufweist, die bei Blick in Richtung auf die Breite des Ölspalts (7) größer als die Breite des Ölspalts (7) ist.

2. Gleichstrom-Durchführung (24), aufweisend:

eine einen unteren Abschnitt der Gleichstrom-Durchführung (24) bildende Porzellanröhre (1), die in isolierendes Öl (23) getaucht ist, das in einem Tank (11) enthalten ist,

eine an einem unteren Endabschnitt der Porzellanröhre (1) vorgesehene isolierte untere Abschirmung (5), die eine Abschirmelektrode (3) beinhaltet, die von einer isolierenden Abdeckung (4) bedeckt ist, und

eine Abschirmbarriere (9), die um den äußeren Umfang der isolierten unteren Abschirmung (5) herum angeordnet ist, so daß zwischen der Abschirmbarriere (9) und der isolierten unteren Abschirmung (5) ein Ölspalt (7) besteht,

**dadurch gekennzeichnet, daß** die Abschirmbarriere (9) aus einem festen Isolator mit höherem Volumenwiderstand als Ölimprägniertes Papier ausgebildet ist.

3. Gleichstrom-Durchführung nach Anspruch 2, wobei die Abschirmbarriere (9) mit einer Dicke (W2) ausgelegt ist, die bei Blick in Richtung auf die Breite des Ölspalts (7) größer als die Breite des Ölspalts (7) ist.

**Revendications**

1. Traversée à courant continu (24), comportant :

un tube en porcelaine (1) constituant une partie inférieure de ladite traversée à courant continu (24) et immergé dans de l'huile isolante (23) contenue dans un réservoir (11),

une protection isolée inférieure (5) agencée au niveau d'une partie d'extrémité inférieure dudit tube en porcelaine (1), et comportant une électrode de protection (3) recouverte d'un recouvrement isolant (4), et

une barrière de protection (8) disposée autour d'une périphérie extérieure de ladite protection isolée inférieure (5), un espace d'huile (7) étant défini entre ladite barrière de protection (8) et ladite protection isolée inférieure (5),

**caractérisée en ce que** ladite barrière de protection (8) est réalisée en ayant une épaisseur (W2) qui est supérieure à une largeur (W1) dudit espace d'huile (7), comme vu dans la direction de la largeur dudit espace d'huile (7).

2. Traversée à courant continu (24), comportant :

un tube en porcelaine (1) constituant une partie inférieure de ladite traversée à courant continu (24) et immergé dans de l'huile isolante (23) contenue dans un réservoir (11),

une protection isolée inférieure (5) agencée au niveau d'une partie d'extrémité inférieure dudit tube en porcelaine (1), et comportant une électrode de protection (3) recouverte d'un recouvrement isolant (4), et

une barrière de protection (9) disposée autour d'une périphérie extérieure de ladite protection isolée inférieure (5), un espace d'huile (7) étant défini entre ladite barrière de protection (9) et ladite protection isolée inférieure (5),

**caractérisée en ce que** ladite barrière de protection (9) est formée d'un isolant plein ayant une résistivité volumique supérieure à du papier imprégné d'huile.

3. Traversée à courant continu selon la revendication 2,

dans laquelle ladite barrière de protection (9) est réalisée en ayant une épaisseur (W2) qui est supérieure à une largeur (W1) dudit espace d'huile (7), comme vu dans la direction de la largeur dudit espace d'huile (7).

FIG. 1  
PRIOR ART

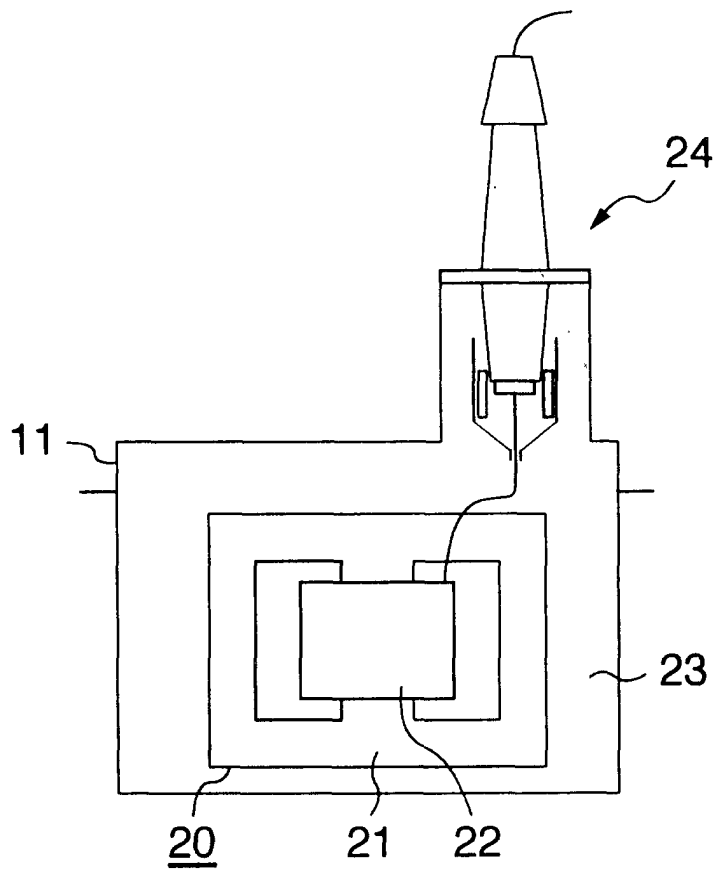

FIG. 2  
PRIOR ART

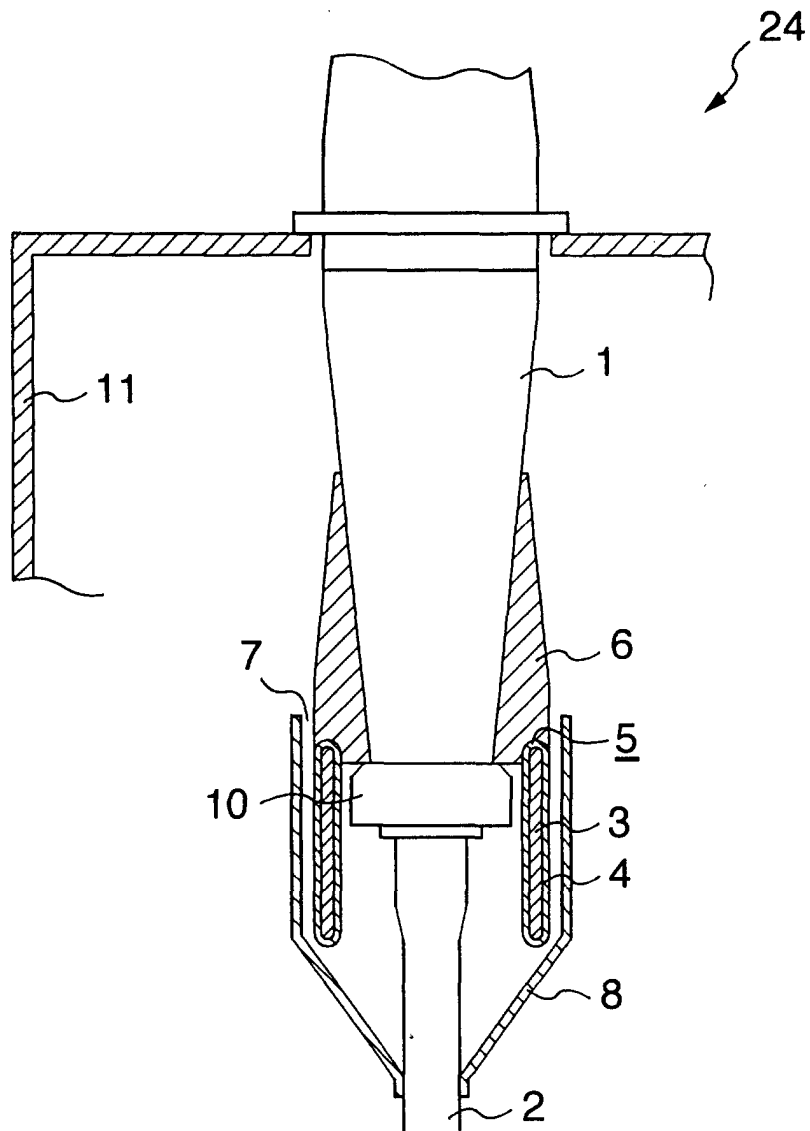

FIG. 3

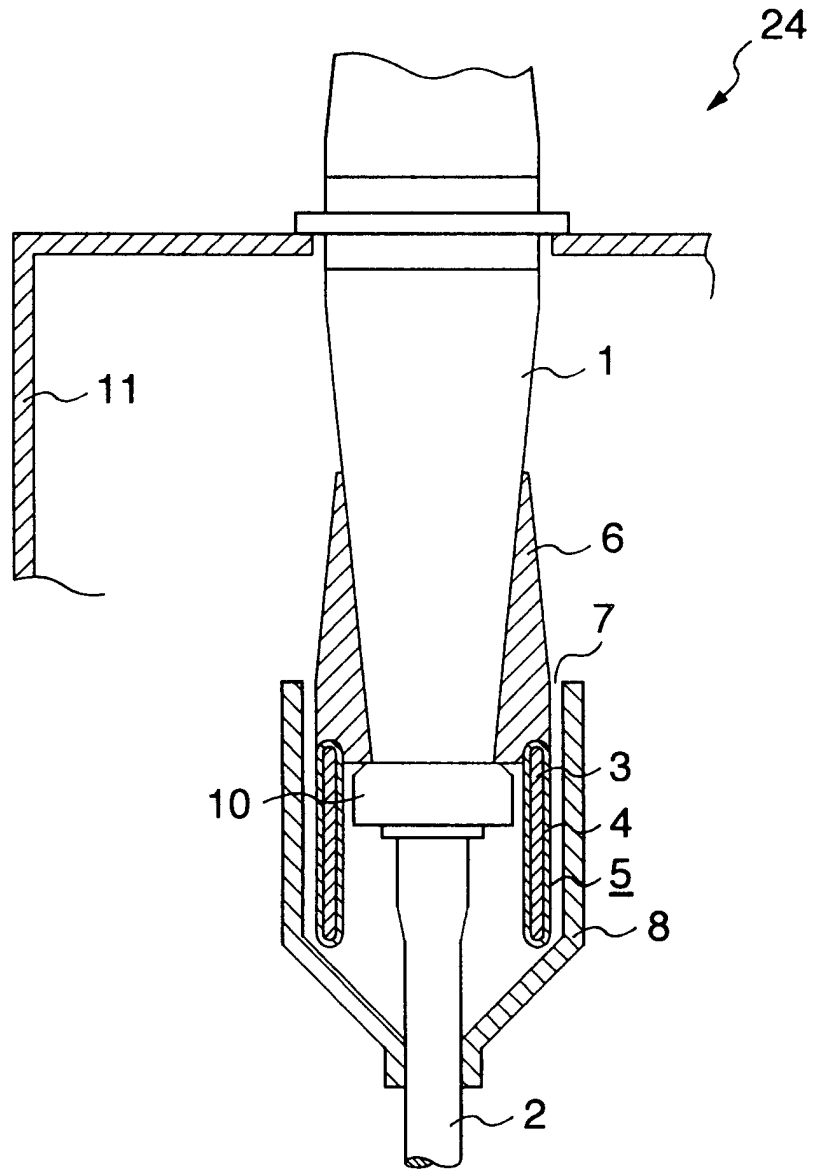

FIG. 4 PRIOR ART

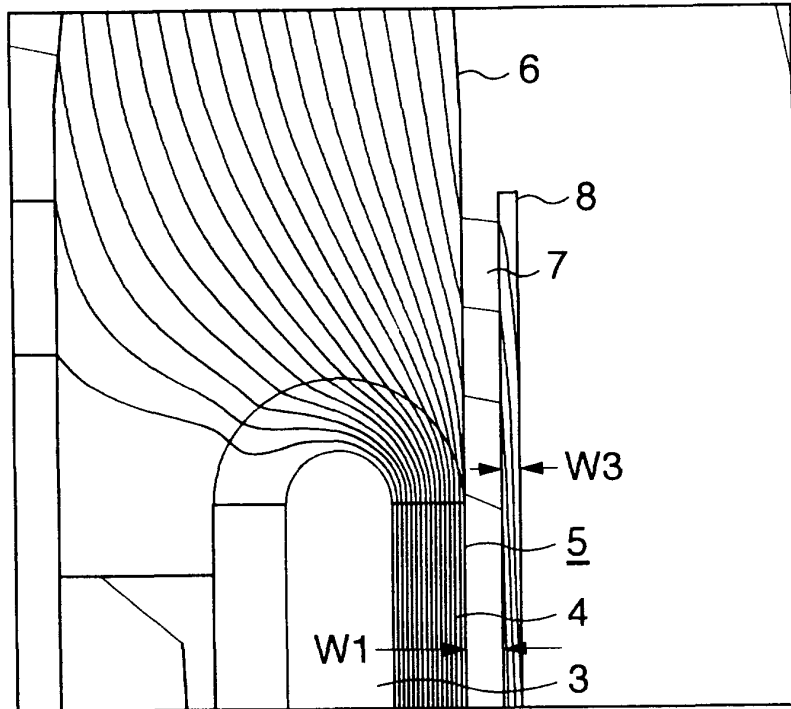

FIG. 5

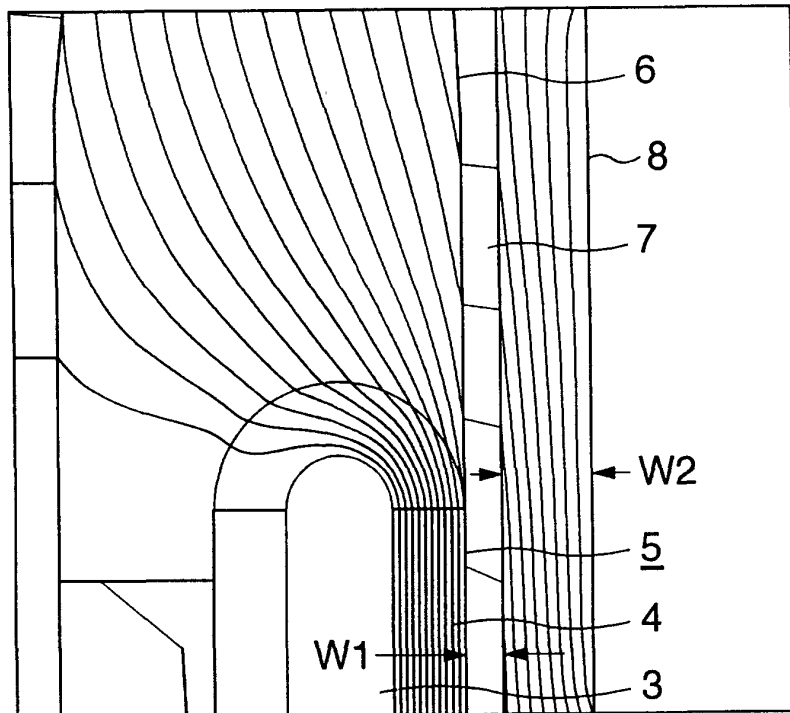

FIG. 6

