

(12) EUROPEAN PATENT APPLICATION

(43) Date of publication:  
08.10.1997 Bulletin 1997/41

(51) Int. Cl.<sup>6</sup>: C22C 23/02, C22C 1/02,  
B22D 21/00, B22D 21/04,  
B22D 17/00

(21) Application number: 97105641.1

(22) Date of filing: 04.04.1997

(84) Designated Contracting States:  
DE FR GB IT

(30) Priority: 04.04.1996 JP 82832/96

(71) Applicant: Mazda Motor Corporation  
Aki-gun, Hiroshima 735 (JP)

(72) Inventors:  
• Sakamoto, Kazuo  
Hiroshima-shi, Hiroshima 734 (JP)

• Yamamoto, Yukio  
Hiroshima-shi, Hiroshima 730 (JP)  
• Sakate, Nobuo  
Hiroshima-shi, Hiroshima 736 (JP)  
• Hirabara, Shoji  
Kure-shi, Hiroshima 737 (JP)

(74) Representative: Müller-Boré & Partner  
Patentanwälte  
Grafinger Strasse 2  
81671 München (DE)

(54) Heat-resistant magnesium alloy member

(57) A heat-resistant magnesium alloy member having specially excellent molding property and elongation while keeping creep resistance property, which comprises 2 to 6% by weight of aluminum and 0.5 to 4% by weight of calcium, and the balance comprising magnesium and inevitable impurities, having a Ca/Al ratio of no more than 0.8, preferably no more than 0.6. The method of preparing the heat-resistant magnesium alloy member is characterized in a semi-solid injection molding at a range between a solidus temperature of the alloy and a liquidus temperature of the alloy.

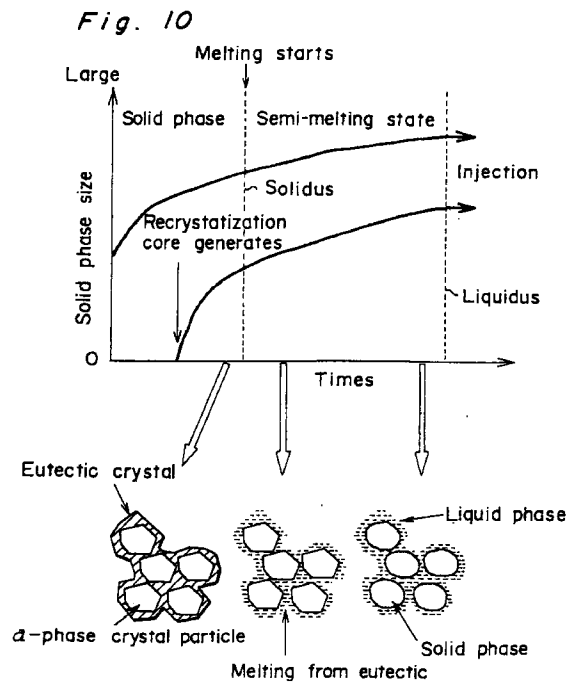

**Description**

The present invention relates to a heat-resistant magnesium alloy member having an excellent molding property and an excellent elongation property while keeping creep resistance property, its starting alloy compound, and a method of preparing the heat-resistant magnesium alloy member.

Magnesium alloy is the most low density one of the metal materials which are in practically use at present, and is strongly expected as a lightweight material for automobiles in future. The magnesium alloy which is most popularly used at present is Mg-Al-Zn-Mn alloy (e.g., AZ91D alloy), and as it has a high strength at a room temperature and a good corrosion resistance, it is applied to transmission cases for an automobile, cylinder head covers, and the like. However, it has such defects that, at a temperature range exceeding 120°C, it begins to show loss of strength characteristics, and especially becomes inferior in creep resistance, leading to a problem of yielding of bearing surface of the screw tightening part on the level of the packaged product.

On the other hand, as an aluminum alloy having an improved heat-resistance, there is used Mg-Al-Si AS41 magnesium alloy. However, though said alloy shows better creep resistance than the above AZ91D, it shows insufficient characteristics in the neighborhood of 150°C of the use temperature, and moreover, as it shows low tensile strength characteristics at both room temperature and high temperature, it is required to be of thick wall to secure the required strength, thereby providing a problem of lowering the weight lightening effect due to magnesium materials.

Besides, there are alloys such as QE22 with addition of silver or rare earth metals to improve a heat resistance thereof, but they have defects of being expensive and not suited to die-cast due to a poor casting property.

For the above reasons, there came to be newly proposed Mg-Al-Ca-Mn alloy (Japanese Laid-open Patent Publication HEI6-25790/1994) having excellent strength at high temperature. Here, it is said that, especially when the Ca/Al ratio is set to be more than 0.7, preferably more than 0.75, precipitates to be crystallized in the magnesium alloy convert into Mg-Ca compounds which crystallize, resulting in production of high temperature strength characteristics.

However, it has been found that, in a case of die-casting a member with a magnesium alloy having a high Ca/Al ratio, there often occur hot cracks, and due to a high melting temperature there easily occurs seizure to the metal mold.

In view of the problems held by the conventional techniques as above, a first object of the present invention is to provide a heat-resistant magnesium alloy member having excellent molding property and elongation while maintaining the physical properties, especially creep resistance, suited to the engine parts of automobiles and the like.

A second object of the present invention is to provide a pertinent molding method for preparing the above heat-resistant magnesium alloy member in place of conventional die-cast methods.

Further, a third object of the present invention is to provide an alloy composition suited for producing a heat-resistant magnesium alloy member having the excellent molding property and elongation while maintaining the creep resistance.

As a result of the repeated reviews to solve the above problems, the present inventors have found out that, in the Al-Ca magnesium alloy, when a semi-solid molding method of injection molding under the state of solid phase and liquid phase being present in mixture is applied in place of the die-cast method, the seizure of metal mold can be prevented, and also an excellent strength can be imparted to the molded member. However, in order to maintain the state of presence in mixture of solid phase and liquid phase, it is necessary to increase the addition amount of aluminum as large as possible.

On the other hand, aluminum dissolves in magnesium in solid state and shows age-hardening, and it is added to increase the mechanical properties of alloy, but it is recommended to add calcium so as to maintain the Ca/Al ratio to 0.7 or more to strengthen the high temperature strength which is in a tendency to be lowered by the addition of Al to Mg (Japanese Patent Laid-open Publication HEI6-25790/1994). However, when the Ca amount is large, casting cracks and seizure to metal mold often occur in molding, and additionally, a large amount of Mg-Ca compound crystallizes, with the result that there is a tendency of lowering of the elongation of the molded product, and it has been found that it is rather necessary to make the Ca/Al ratio no more than 0.8.

Accordingly, in the present invention, based on the above two findings, there is provided a magnesium alloy molding member comprising 2 to 6% by weight of aluminum and 0.5 to 4% by weight of calcium, and the balance of magnesium and unavoidable impurities, wherein a Ca/Al ratio is no more than 0.8, to have an excellent anti-creep property, molding property, and elongation.

In general, in the magnesium alloy, in order to obtain solid phase dissolution in magnesium, to exhibit age-hardening, and to elevate mechanical strength, it has been understood to be preferable to add 2 - 10% by weight of aluminum. While it is necessary in the present invention to add more than 2% by weight of aluminum, when the amount of addition exceeds 6% by weight, it has been found that the elongation is lowered even if the semi-solid injection molding would be carried out. Accordingly, in order to obtain the designed effect while carrying out the semi-solid injection molding, it has been found that the addition amount should be limited to no more than 6% by weight. On the other hand, calcium is added to increase the high temperature strength which is in a tendency to be lowered by the addition of aluminum to magnesium, but it has been found that it is necessary to suppress the Ca/Al ratio to no more than 0.8 to prevent lowering of the molding property and elongation of the molding member, and in addition, the Ca amount should be limited to

0.5 - 4% by weight.

Strontium is used as a micronizing agent in the casting of magnesium, and as it can display the micronizing effect in solid phase in the semi-solid injection molding of the present invention, it is preferably added. The suitable addition amount is no more than 0.15% by weight.

5 The above molding member shows the crystal particle size of no more than 30  $\mu\text{m}$  with the tensile strength of 180 Mpa (298°K; ref. Fig. 9) or more, and excellent creep resistance of the minimum creep rate of no more than  $4 \times 10^{-10}/\text{S}$  under the test temperature of 150°C and the test load of 50 MPa (according to JIS Z 2271 "method of tensile creep test of metal material"). Accordingly, it is suitable for the transmission part or engine part for automobiles. Especially, when the Ca/Al ratio is no more than 0.6, the molding member shows a more excellent creep resistance.

10 The present invention is to provide a heat-resistant magnesium alloy material to be molded by a semi-solid injection molding while maintaining excellent creep resistance property with the excellent molding property and elongation, comprising as an alloy material to be used for molding the above magnesium alloy molding part heat-resistant magnesium comprising 2 to 6% by weight of aluminum and 0.5 to 4% by weight of calcium, and the balance of magnesium and unavoidable impurities, and preferably further Sr of no more than 0.15% by weight, with adjustment, if necessary, of a Ca/Al ratio of no more than 0.8, preferably a Ca/Al ratio of no more than 0.6.

15 Especially, as for the alloy material, in case of molding by a semi-solid injection molding method, it has been found that the material in the form of metal particles or pellets into which internal strain is introduced is effective for micronizing the crystals (ref. Fig. 10). As for the processing method for the metal particles or pellets, a cutting method is advantageous costwise.

20 Further, in case of applying a semi-solid injection molding wherein an injection molding is carried out in the state of a solid phase and a liquid phase being present in mixture, practice can be made at a temperature lower than a liquidus temperature. Accordingly, the present invention is to provide a method for molding a heat-resistant magnesium alloy member characterized by carrying out a semi-solid injection molding, while maintaining an excellent creep resistance property with having an excellent molding property and elongation.

25 Against the fact that the die-cast method is in general to make injection into the metal mold at a temperature of 30 - 50°C above a melting temperature, in the semi-solid injection molding of the present invention, injection can be made at a temperature higher than the solidus temperature of the alloy and lower than the liquidus temperature, and accordingly the injection temperature is lowered by at least 30 - 60°C, so that the seizure to the metal mold can be prevented.

It can be understood that, since solidification takes place from a semi-solid state in the present invention, and coagulation stress therewith becomes small, generation of hot cracking can be prevented due to this method mechanism.

30 Especially, in the semi-solid molding method, in the range of no more than 30% by weight of the solid phase rate, these prevention and effect on a flow length become remarkable (ref. Fig. 8), and the generation of hot cracking can be effectively prevented. Accordingly, in case of carrying out the semi-solid molding, the solid phase ratio in the semi-solid state is preferably no more than 30%. In general, it has been understood that a higher solid phase ratio is more advantageous for the seizure and coagulation stress, but in the present invention method, when the solid phase rate is high, the fluidity is lowered to give a tendency of lowering in filling property and generation of cold shut, thereby making it difficult to obtain a sound molding member.

It has been found that, especially when the average particle size of these coagulation textures is no more than 30  $\mu\text{m}$ , the elongation amount shows specially large improvement.

40 The above magnesium alloy may further contain no more than 2% by weight of at least one element selected from the group consisting of zinc, manganese, zirconium, and silicon, and/or no more than 4% by weight of a rare earth metal (e.g., yttrium, neodymium, lanthanum, cerium, misch metal). These are to improve the strength or high temperature strength of the above magnesium alloy effectively in the range no more than the upper limit thereof.

45 Fig. 1 is a schematic diagram showing the constitution of the molding machine to be used for the semi-solid molding process and injection molding process according to the present invention.

Fig. 2 is a graph for making comparison of the creep characteristics of various magnesium alloy molding members.

Fig. 3 is a graph to show the relations between the Ca/Al ratio and the elongation at room temperature in various magnesium alloy molding members.

Fig. 4 is a schematic diagram showing a metal mold for testing casting cracks.

50 Fig. 5 is a graph showing the relation between the solid phase diameter and the staying time.

Fig. 6 is a graph showing the minimum creep strain rates of various magnesium alloy molding members.

Fig. 7 is a schematic diagram showing the metal mold for evaluating the flowing properties of various magnesium alloys.

Fig. 8 is a graph showing the relations between the solid phase ratio and the flowing length in the alloy composition in Example 2 measured by using a metal mold of Fig. 7.

Fig. 9 is a graph showing the relations between the average crystal particle size and the tensile strength of the member molded from the alloy composition of Example 3.

Fig. 10 is a schematic diagram showing the solid phase growth stages in the cases of using the metal particles having no work strain and those having the work strain.

In Fig. 1, there is shown the whole constitution of the molding machine 1 to be used for the semi-solid molding method according to the present invention. In the molding method of the present invention, the material 3 of magnesium alloy metal particles or pellets (more than 3 mm in diameter) manufactured by the method of cutting or the like is charged into the hopper 8 in the drawing. The material 3 is supplied to the cylinder 4 from the hopper 8 through the inlet 7 of argon atmosphere. In this cylinder 4, the material 3 is heated while being sent forward by the screw 2. This heating zone is shown by the mark 10. At an approximate liquidus temperature of heating, the magnesium alloy material 3 shows a molten state, but at a level lower than the liquidus temperature the material becomes semi-solid condition in which the solid phase and the liquid phase are present in mixture, as illustrated. Also, in the magnesium alloy which is in a semi-solid condition, its shearing force acts to separate the solid phase finely as illustrated by agitation by the screw rotation. Here, when the screw 2 is pushed forward with the rear high speed injection mechanism 5, the molten material in which the solid phase has been finely cut under the semi-solid state is injected at high speed from the nozzle 9 as illustrated and filled in the metal mold 6. Here, the contents in the metal mold are held under pressure until solidification, and thereafter the metal mold is opened to take out the molding product.

#### 15 Examples 1 - 7 and Comparative Examples 1 - 5

An iron crucible is installed in a low frequency furnace, and while flowing 1% of the SF<sub>6</sub> gas (rest is dry air) on the surface of the molten material, the alloys having the components of Examples and Comparative Examples were prepared by melting. The resulting alloys were cast on a plate to prepare 3 - 5 mm diameter pellets by milling. Using these as raw materials, semi-solid molding was carried out by using the above molding machine.

[Table 1]

		Chemical Composition (Wt.%)					
		Al	Ca	Si	Mn	Sr	Mg
Example 1	Mg-3Al-2Ca	2.98	2.05	0.30	0.25	-	Remainder
Example 2	Mg-4Al-2Ca	3.95	2.02	0.30	0.32	-	↑
Example 3	Mg-4Al-3Ca	4.02	3.06	0.25	0.28	-	↑
Example 4	Mg-6Al-3Ca	5.97	3.10	0.28	0.30	-	↑
Example 5	Mg-4Al-2Ca-0.03Sr	3.87	2.06	0.25	0.25	0.03	↑
Example 6	Mg-4Al-2Ca-0.09Sr	4.02	1.98	0.30	0.23	0.09	↑
Example 7	Mg-4Al-2Ca-0.15Sr	4.05	2.10	0.23	0.25	0.15	↑
Comparative Example 1	ASTM AS41 Equivalent	4.39	-	0.45	0.28	-	↑
Comparative Example 2	Mg-9Al-0.5Ca	8.70	0.49	0.90	0.21	-	↑
Comparative Example 3	ASTM AZ91D Equivalent	8.84	-	0.02	0.22	-	↑
Comparative Example 4	Mg-4Al-4Ca	4.02	3.96	0.32	0.32	-	↑
Comparative Example 5	Mg-3Al-3Ca	2.75	2.71	0.27	0.36	-	↑

For the semi-solid molding, a machine having the clamping force of 450 t was used under the conditions of injection speed at the metal mold gate part of 50 m/s, injection pressure of about 700 kg/cm<sup>2</sup>, and the temperature of the alloy at the nozzle part was set to be lower than the liquidus level of 550 - 580°C. Under the above molding conditions a tensile test piece (JIS No.4 test piece) was prepared, with which the creep property at 150°C, 50 MPa was examined by the tensile creep test method based on JIS Z 2271. The results are shown in Fig. 2. It can be seen that the magnesium alloy of the present invention is more excellent in creep resistance characteristic than AS41 which is commented as being superior in creep resistance to AZ91D of Comparative Example 3.

Further, the breaking strength and breaking elongation were measured with an instron tensile tester at a cross head rate of 10 mm/min. and at a measuring temperature of 25°C. The results are shown in Table 2. It can be seen that, in comparison with Comparative Example 2 in which the aluminum content exceeds the present invention range of 2 - 6% by weight and Comparative Example 4 in which the aluminum and calcium contents lie within the present invention range but the Ca/Al ratio exceeds by 0.8, the Examples containing 2 - 6% by weight of aluminum and 0.5 - 4% by weight of calcium and having the Ca/Al ratio of no more than 0.8 show excellent elongation.

[Table 2]

	Al amount (Wt.%)	Ca amount (Wt.%)	Elongation (%)
Example 2	3.95	2.02	6.7
Example 3	4.02	3.06	7.0
Example 4	5.97	3.10	5.2
Comparative Example 2	8.70	0.49	0.8
Comparative Example 4	4.02	3.96	1.2

Then, in Examples and Comparative Examples, the relations between the Ca/Al ratio and the above elongation are illustrated in Fig. 3, from which it can be seen that when the Ca/Al ratio exceeds 0.8, the elongation is sharply lowered. In this connection, when the relations between the Ca/Al ratio and the minimum creep rate of strain are observed, as shown in Fig. 6, in case of the Ca/Al ratio being no more than 0.6 (Example 2), the smaller creep rate of strain is shown, and it can be seen that the creep resistance property becomes more excellent.

Further, when the semi-melting molding was carried out by using the metal mold for test as shown in Fig. 4 and securing the illustrated running, there were obtained the results as shown in Table 3. As a result, it was seen that when the Ca/Al ratio approached 1, casting cracks were formed on the overflow side at the top end of the cylindrical part, but at the Ca/Al ratio of no more than 0.8, no such casting crack was formed at all.

[Table 3]

	Ca/Al weight ratio	Casting crack formed or not
Example 1	0.69	No
Example 2	0.51	No
Example 3	0.76	No
Example 4	0.52	No
Comparative Example 1	0.99	Yes
Comparative Example 5	0.99	Yes

In general, when the staying time in casting is extended, the solid phase diameter is sharply increased (Example in Fig. 5), but it can be seen that, when strontium is added, the crystal micronizing effect is actuated to suppress the increment in the solid phase diameter attributed to the staying time.

Using the alloy material of Example 2, the semi-solid molding temperature was varied in the metal mold for evaluating flowing property as shown in Fig. 7, the molten material was introduced in the illustrated direction, and its flowing property was evaluated. The results are shown in Fig. 8. From the results it can be seen that, when the solid phase rate exceeds 30%, the flow length is sharply lowered, and as this flow gives effect on the particle size of the texture crystals of the molding material, desirably the molding is made under the solid phase condition of no more than 30% in the semi-solid molding method.

In the semi-solid molding, the magnesium alloy material is used in the form of the metal particles or pellets. When work strain is given inside the metal particles by cutting work or the like, the metal particles form the nuclei of recrystallization shortly after the heating, and increase the solid phase diameter. Therefore, when comparison is made between the case of using the metal particles having no work strain and that of using the metal particles having work strain, it can be understood that the growth rates of the solid phase are different as shown in Fig. 10, and the latter is superior to the former in the point of micronization of the crystal particle size of the molding member.

As will be apparent from the above description, according to the present invention, it is possible to obtain a molding member having excellent creep resistance characteristic at high temperature by controlling Ca/Al ratio in Mg-Al-Ca heat resistant magnesium alloy member. Therefore, it is possible to produce the transmission parts for automobiles such as clutch piston and clutch drum and engine parts such as rocker arm with the lightweight magnesium alloy to give a suf-

ficient durability.

Further, according to the present invention, by carrying out semi-solid molding at a temperature lower than the liquidus level, the problems of hot crack and seizure to the metal mold which had been remarkable in the conventional die-cast process are dissolved, and on the other hand, the strength at room temperature and high temperature along with elongation equivalent to or higher than those of the conventional process can be retained.

### Claims

1. A heat-resistant magnesium alloy member having excellent creep resistance property which comprises 2 to 6% by weight of aluminum and 0.5 to 4% by weight of calcium, and the balance of magnesium and inevitable impurities, wherein a Ca/Al ratio thereof is no more than 0.8.
2. The heat-resistant magnesium alloy member according to Claim 1, having a Ca/Al ratio of no more than 0.6, and creep resistance property of no more than  $4 \times 10^{-10}$ /S of minimum creep rate under the test temperature of 150°C and the test load of 50 Mpa.
3. The heat-resistant magnesium alloy member according to Claim 1 or 2, wherein the magnesium alloy further contains no more than 0.15% by weight of Sr.
4. The heat-resistant magnesium alloy member according to any one of Claims 1 to 3, wherein the average particle size of the crystals is no more than 30  $\mu\text{m}$ .
5. The heat-resistant magnesium alloy member according to any one of Claims 1 to 4, wherein the molding parts are the transmission parts or engine parts for automobiles.
6. A heat-resistant magnesium alloy composition comprising 2 to 6% by weight of aluminum and 0.5 to 4% by weight of calcium, and the balance of magnesium and inevitable impurities, which gives excellent creep resistance property by a semi-solid injection molding at a temperature range between a solidus temperature of the alloy and a liquidus temperature of the alloy wherein the solid phase and the liquid phase are present in mixture.
7. The heat-resistant magnesium alloy composition according to Claim 6, wherein the magnesium alloy further contains no more than 0.15% by weight of Sr.
8. The heat-resistant magnesium alloy composition according to Claim 6 or 7, having a Ca/Al ratio of no more than 0.8.
9. The heat-resistant magnesium alloy composition according to Claim 8, having a Ca/Al ratio of no more than 0.6.
10. The heat-resistant magnesium alloy composition according to any one of Claims 6 to 9, being in the form of metal particles or pellets into which internal strain is introduced.
11. A method of molding a heat-resistant magnesium alloy having excellent creep resistance property, which comprises preparing an alloy composition comprising 2 to 6% by weight of aluminum and 0.5 to 4% by weight of calcium, and the balance of magnesium and inevitable impurities; subjecting said alloy composition to a semi-solid injection molding at a temperature range between a solidus temperature of the alloy and a liquidus temperature of the alloy wherein a solid phase and a liquid phase are present in mixture.
12. The method of molding a heat-resistant magnesium alloy member according to claim 11, wherein the solid phase rate in semi-melt state is no more than 30% at the time of carrying out an injection molding.

Fig. 1

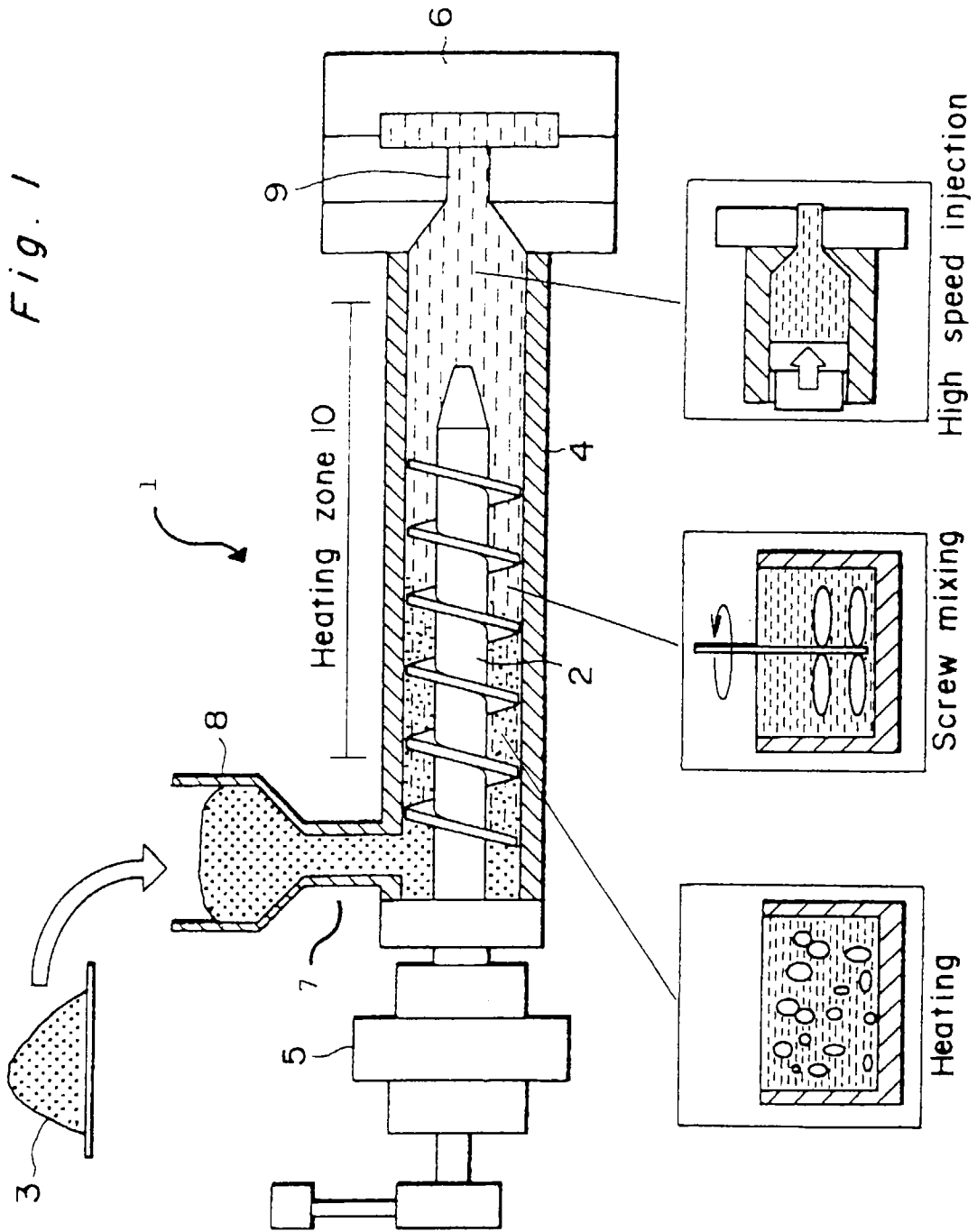

Fig. 2

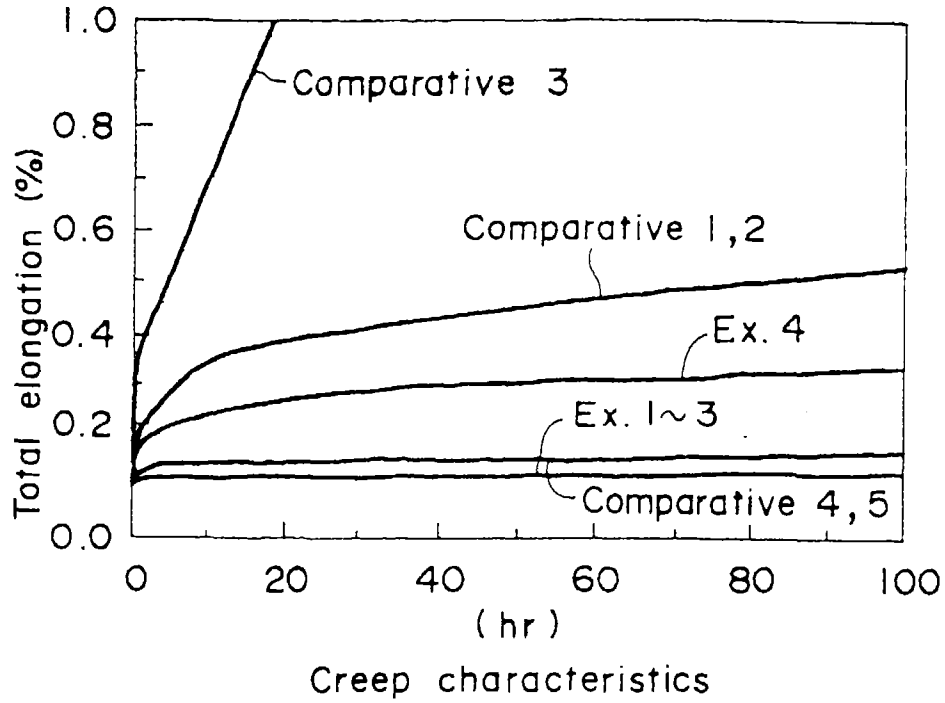

Fig. 3

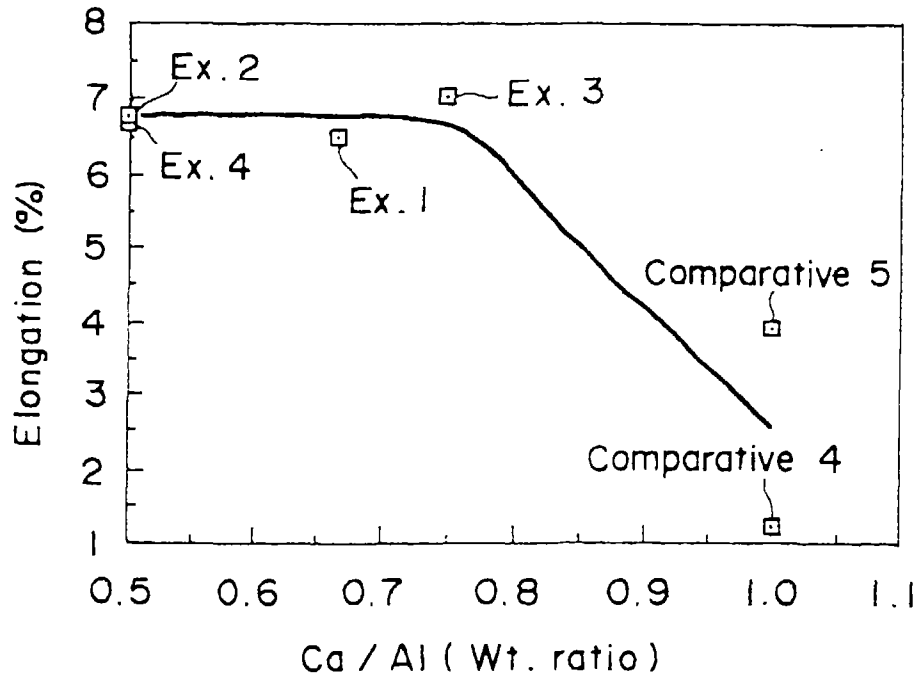



Fig. 4

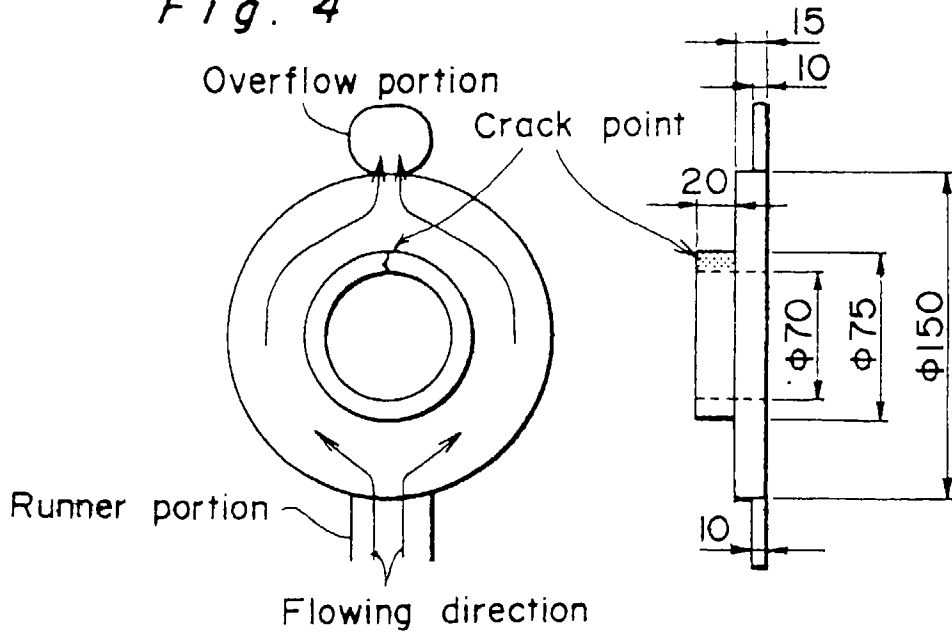

Fig. 5

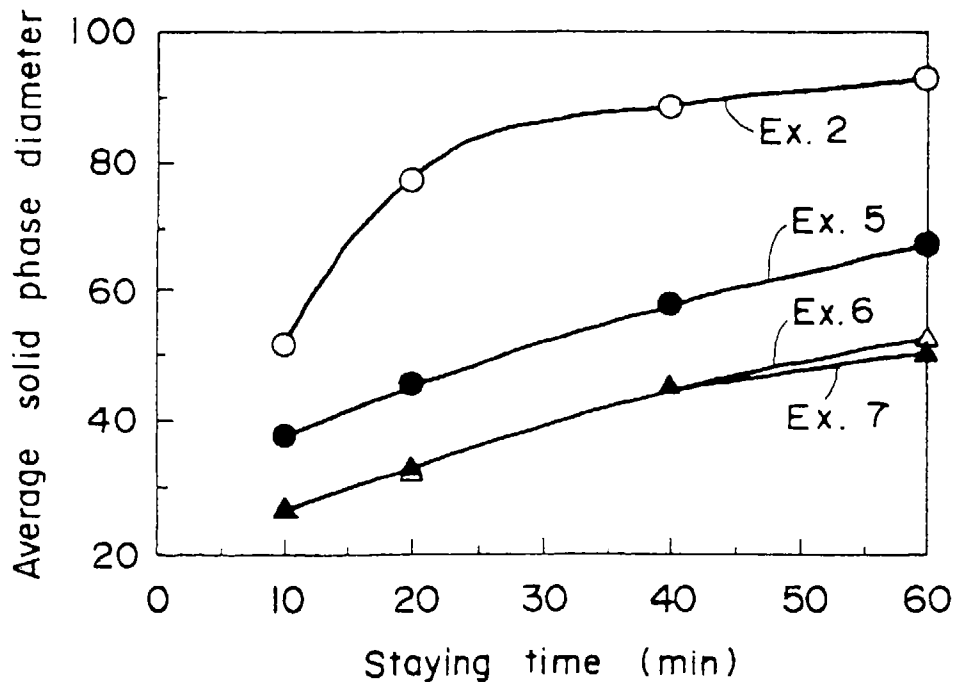

Fig. 6

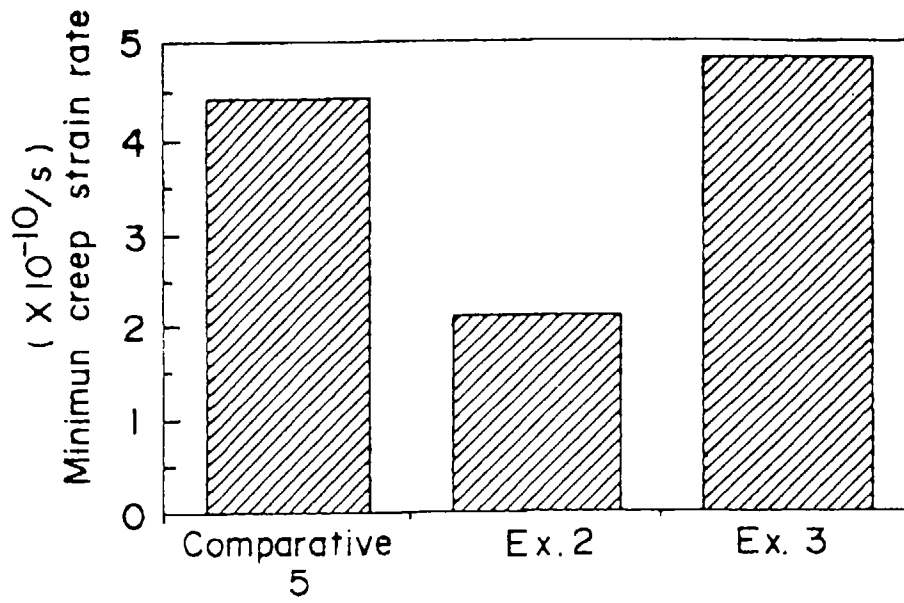

Fig. 7

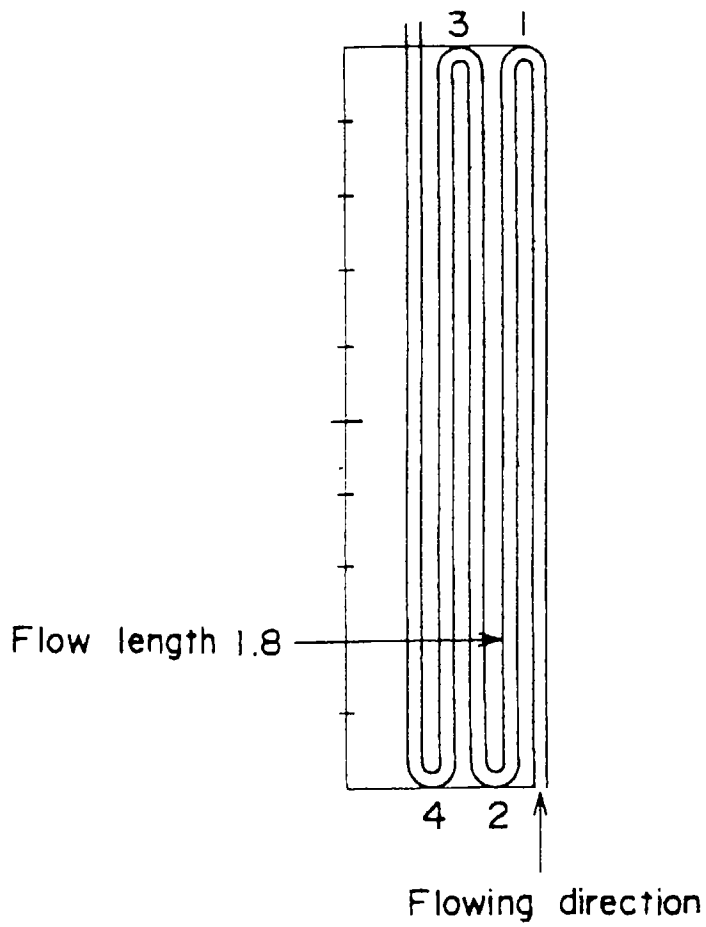

Fig. 8

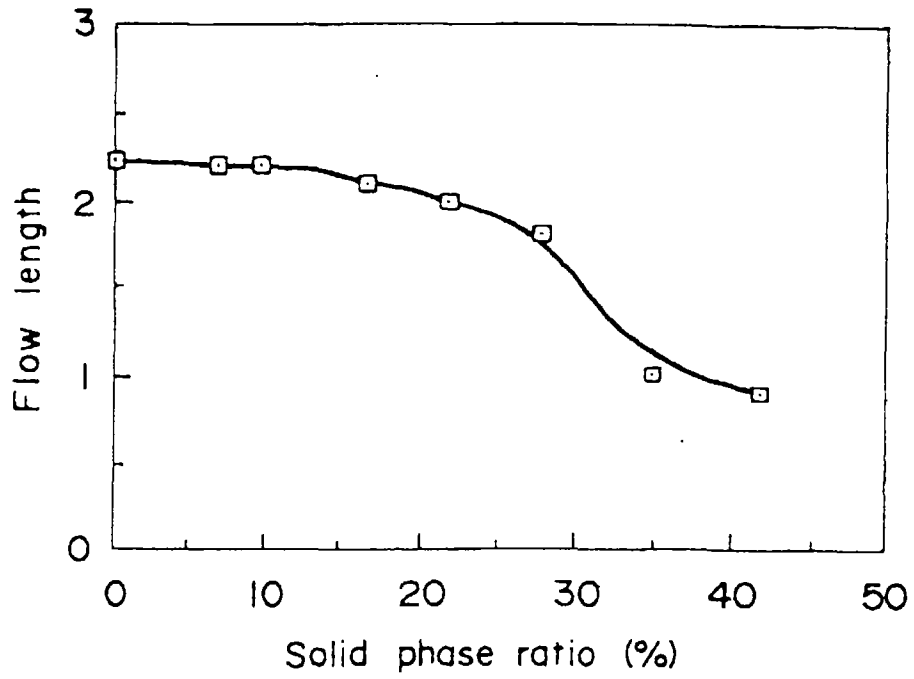

Fig. 9

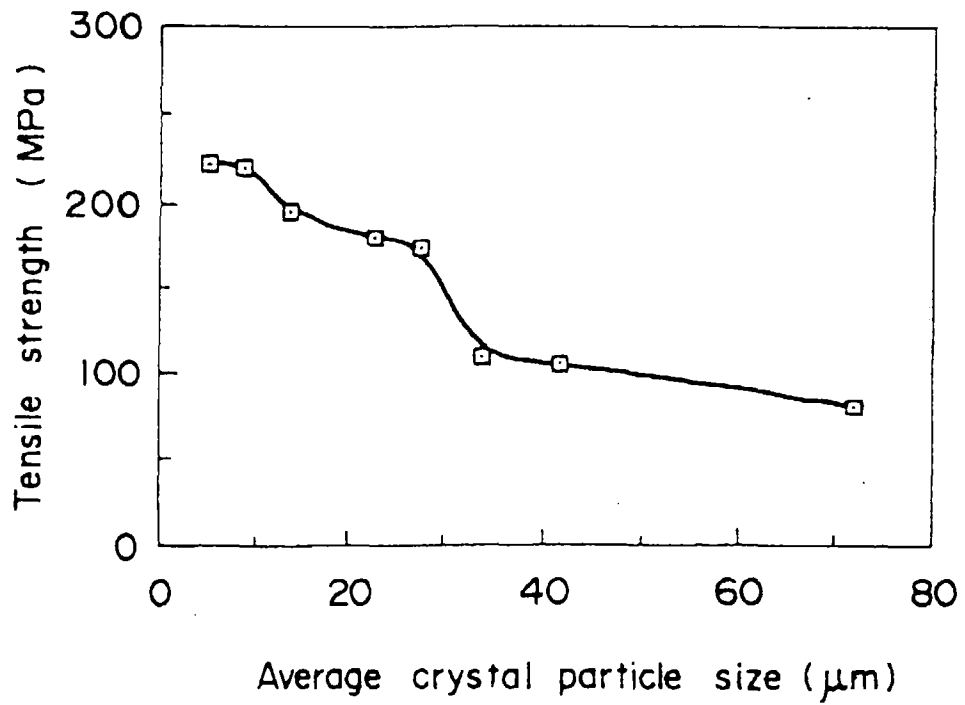
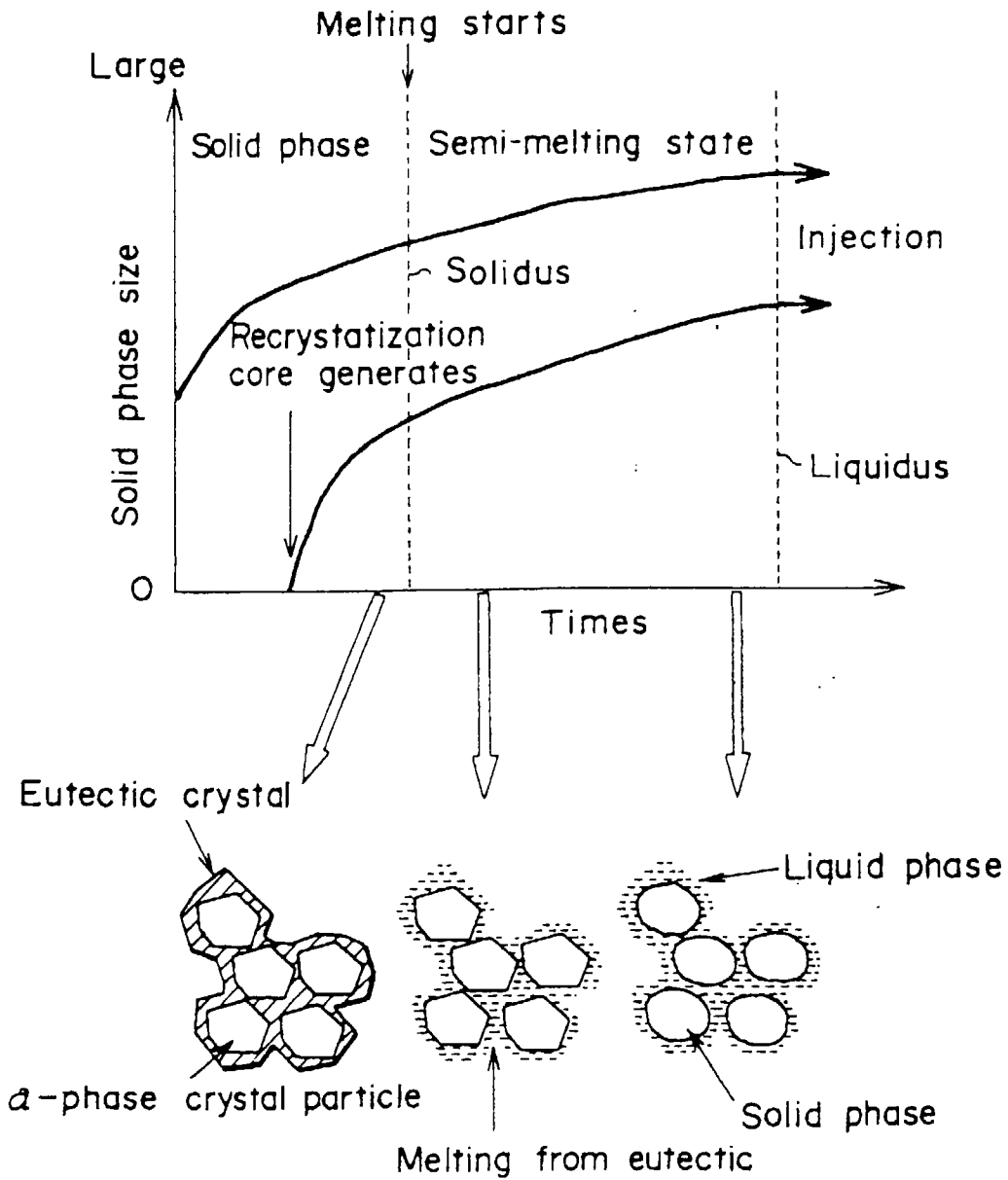

Fig. 10





European Patent  
Office

EUROPEAN SEARCH REPORT

Application Number  
EP 97 10 5641

DOCUMENTS CONSIDERED TO BE RELEVANT			
Category	Citation of document with indication, where appropriate, of relevant passages	Relevant to claim	CLASSIFICATION OF THE APPLICATION (Int.Cl.6)
X,P	WO 96 25529 A (INST LA TECHNOLOGIE DU MAGNESI) 22 August 1996 * tables 2,6 *	1-10	C22C23/02 C22C1/02 B22D21/00 B22D21/04 B22D17/00
X	--- PATENT ABSTRACTS OF JAPAN vol. 095, no. 004, 31 May 1995 & JP 07 011374 A (UBE IND LTD;OTHERS: 01), 13 January 1995, *see GB-A-2 296 256, table 1* * abstract *	1-10	
Y	---	11,12	
X	WO 89 08154 A (PECHINEY ELECTROMETALLURGIE ;NORSK HYDRO AS (NO)) 8 September 1989 * table 1 *	1-4,6-10	
Y	---	11,12	
X	EP 0 419 375 A (PECHINEY ELECTROMETALLURGIE ;NORSK HYDRO AS (NO)) 27 March 1991 *samples 9 and 11 on page 4*	1-4,6-8	
Y	---	11,12	
X	--- PATENT ABSTRACTS OF JAPAN vol. 096, no. 006, 28 June 1996 & JP 08 041576 A (HONDA MOTOR CO LTD), 13 February 1996, *see tables on pages 4 and 5 of patent document* * abstract *	1-10	TECHNICAL FIELDS SEARCHED (Int.Cl.6) C22C B22D
Y	---	11,12	
X	--- PATENT ABSTRACTS OF JAPAN vol. 096, no. 004, 30 April 1996 & JP 07 331375 A (TOYOTA MOTOR CORP;OTHERS: 01), 19 December 1995, *see sample A in table on page 4 of patent document* * abstract *	1-10	
Y	---	11,12	
	-/--		
The present search report has been drawn up for all claims			
Place of search MUNICH		Date of completion of the search 4 July 1997	Examiner Badcock, G
CATEGORY OF CITED DOCUMENTS		T : theory or principle underlying the invention E : earlier patent document, but published on, or after the filing date D : document cited in the application L : document cited for other reasons ..... & : member of the same patent family, corresponding document	
X : particularly relevant if taken alone Y : particularly relevant if combined with another document of the same category A : technological background O : non-written disclosure P : intermediate document			

EPO FORM 1503 03.82 (P/M/C01)



European Patent  
Office

## EUROPEAN SEARCH REPORT

Application Number  
EP 97 10 5641

DOCUMENTS CONSIDERED TO BE RELEVANT			
Category	Citation of document with indication, where appropriate, of relevant passages	Relevant to claim	CLASSIFICATION OF THE APPLICATION (Int.Cl.6)
X	PATENT ABSTRACTS OF JAPAN vol. 096, no. 002, 29 February 1996 & JP 07 278717 A (UBE IND LTD;OTHERS: 01), 24 October 1995,	1-10	
Y	*see tables on pages 4 and 5 of patent document* * abstract *	11,12	
X	--- PATENT ABSTRACTS OF JAPAN vol. 095, no. 008, 29 September 1995 & JP 07 118785 A (MITSUI MINING & SMELTING CO LTD), 9 May 1995,	1-10	
Y	*see samples in tables on pages 3 and 4 of patent document* * abstract *	11,12	
Y	--- CANADIAN INST. OF MINING, METALLURGY AND PETROLEUM, MONTREAL, CANADA; CONFERENCE: RECENT METALLURGICAL ADVANCES IN LIGHT METALS INDUSTRIES., 20 - 24 August 1995, VANCOUVER, CANADA, pages 473-479, XP002034402 GHOSH, D. ET AL.: "Development of ductile thixomolded magnesium alloys." *see whole document*	11,12	TECHNICAL FIELDS SEARCHED (Int.Cl.6)
Y	--- INSTITUTE OF METALS AND MATERIALS AUSTRALASIA, THE MATERIALS SOCIETY OF THE IEAUST., AUSTRALIA, CONFERENCE: MATERIALS IN THE AUTOMOTIVE INDUSTRY., 24 - 25 June 1992, MELBOURNE, AUSTRALIA, XP002034403 CHRISTODOULU, P. ET AL.: "Thixotropic forging of metals in the semi-solid state." *see whole document* -----	11,12	
The present search report has been drawn up for all claims			
Place of search MUNICH		Date of completion of the search 4 July 1997	Examiner Badcock, G
CATEGORY OF CITED DOCUMENTS		T : theory or principle underlying the invention E : earlier patent document, but published on, or after the filing date D : document cited in the application L : document cited for other reasons ..... & : member of the same patent family, corresponding document	
X : particularly relevant if taken alone Y : particularly relevant if combined with another document of the same category A : technological background O : non-written disclosure P : intermediate document			

EPO FORM 1503 01/82 (P04C01)