



Europäisches Patentamt
European Patent Office
Office européen des brevets



(11) **EP 0 806 353 B1**

(12) **EUROPEAN PATENT SPECIFICATION**

(45) Date of publication and mention
of the grant of the patent:
04.09.2002 Bulletin 2002/36

(51) Int Cl.7: **B65B 29/02, B65B 57/16**

(21) Application number: **97830192.7**

(22) Date of filing: **24.04.1997**

(54) **Machine for the automated manufacture of infusion bags**

Vorrichtung zum automatischen Herstellen von Aufgussbeuteln

Machine pour la fabrication automatisée de sachets d'infusion

(84) Designated Contracting States:
DE FR GB IT

• **Cicognani, Sergio**
48018 Faenza (FR)

(30) Priority: **09.05.1996 IT BO960259**

(74) Representative: **Lanzoni, Luciano**
c/o BUGNION S.p.A.
Via Goito, 18
40126 Bologna (IT)

(43) Date of publication of application:
12.11.1997 Bulletin 1997/46

(73) Proprietor: **I.M.A. INDUSTRIA MACCHINE**
AUTOMATICHE S.p.A.
40064 Ozzano Emilia (BO) (IT)

(56) References cited:
EP-A- 0 095 542 **EP-A- 0 548 057**
WO-A-93/07061 **US-A- 4 722 168**

(72) Inventors:
• **Ghirlandi, Dante**
40128 Bologna (FR)

EP 0 806 353 B1

Note: Within nine months from the publication of the mention of the grant of the European patent, any person may give notice to the European Patent Office of opposition to the European patent granted. Notice of opposition shall be filed in a written reasoned statement. It shall not be deemed to have been filed until the opposition fee has been paid. (Art. 99(1) European Patent Convention).

Description

[0001] The present invention relates to a machine intended for the automated manufacture of filter bags filled with infusible substances, for example tea, herbal powders and similar products.

[0002] The adoption of filter bags as a means of preparing individual beverages by infusion, both in the home and in catering, is now general practice the world over: it is indeed by virtue of their simplicity and ease of use that filter bags have become so widely accepted.

[0003] In the light of this increased popularity, attempts naturally have been made to maximize the appeal of the single bag, especially by those who distribute the product on the market; one has seen improvements in retention of the particulate substance, in the rate of interaction with liquids during the time allowed for infusion, in shelf life, in ease of final packaging, and so forth...

[0004] For example, one has seen a change from the original bag, appearing as a single envelope with a finger tab label or tag attached by a thread, to the now familiar pattern incorporating two envelopes (also with thread and finger tab label, and in some cases individually wrapped), which is fashioned from a tubular blank of filter paper filled with two distinct measures of the substance and folded double (thereby obtaining a more effective release of the substance due to the larger surface area in contact with the liquid), also to the simpler type of bag consisting in a plain rectangular or circular envelope with no thread or label, which is packed generally in boxes containing one or more rows and without any additional wrapping.

[0005] Reference is made in the present specification to a machine for the manufacture of this latter type of filter bag, and in particular to individual or one-cup bags consisting in single envelopes of rectangular or circular outline, fashioned generally in pairs side by side from a pair of plain filter paper strips placed one against another and sealed along the edges, each containing a measure of the infusible substance.

[0006] In their current form, automatic machines of the type in question (see also Italian patent n° 1 199 414 in the name of the present applicant) comprise a series of stations arranged along a substantially horizontal pass line, by which single bags of the infusible substance are fashioned and made ready for packaging into boxes.

[0007] At a decoiling station located first in sequence along the pass line, a continuous strip of filter paper is drawn from a roll and divided longitudinally into two halves; the first half is directed beneath a station from which measures of the infusible substance are dispensed singly, or alternatively in pairs arranged two abreast, whilst the second half is made to by-pass the dispensing station and then assume a position over the first half, covering the single or paired measures of the substance already deposited on the paper.

[0008] The station next in sequence, or rather positioned following the dispenser along the pass line, comprises means by which to heat seal the external border of the two joined halves and, where the bags are fashioned in pairs, also the mid-line dividing the measures of the infusible substance lying two abreast on the first half; such heat seal means will consist, typically, in a pair of rollers counter-rotating about respective horizontal axes and positioned one directly above the other.

[0009] The continuous strip of bags fashioned in this way is advanced along a table toward a station at which it is severed longitudinally by means of a special cutter, and thereafter through a further station at which it is divided transversely by a second rotary cutter into a plurality of single bags. The discrete bags are then stacked in pairs at a station immediately beyond the transverse cutting station. More exactly, the bags are stacked in a given predetermined number internally of a vertical duct, then, after descending vertically, released onto a moving horizontal surface and conveyed toward subsequent stations either incorporated into or separate from the machine, by which the end product is packed into boxes.

[0010] Each machine unit operating at the various stations mentioned above (dispenser, heat seal rollers, cutters and stackers) is set in motion by a drive system which normally will be centralized, and connected with the single units by way of mechanical transmission links comprising gears, chains or belts; the drive ratios and proportions of these are selected according to the output required from each unit, so as to maintain the production of bags steady and correct, or according to the dimensions of the end product. In other words, the machine operates to certain key parameters, namely the size of the filter bag, which if changed will require adaptation or replacement of the heat seal rollers and the dispenser, and the final packaging format, i.e. the number of bags or pairs of bags destined to make up one box.

[0011] It is also known, as explained in U.S. Pat. No. 4,722,168, a high speed wrapping machine, in which drive motors for an infeed conveyor, finwheels, cut/seal head and a discharge conveyor are electronically controlled by separate, closed-loop controllers, which receive commands from a programmed microprocessor. The microprocessor-based architecture of the horizontal wrapping machine affords significantly great flexibility in the overall setup, initialization, running and change-over upon different product selection.

[0012] Machines structured after this fashion by now have a long pedigree and are able to combine high output per unit of time with an appreciable guarantee of quality in respect of the finished product, but tend at the same time to betray a certain lack of "flexibility" as regards the material requirements of the manufacturer, typically the need to change quickly to a different packaging format (number of bags per box) for a given market, and possibly to make minor alterations to the size and/or shape of the bag. To change the setup of such a

machine, it becomes necessary on each occasion to alter the drive ratio for each one of the stations affected by the change, making manual adjustments to the transmission link between the drive system and the machine unit and thus changing the positions occupied by the units at the start of the cycle. This is done for example with the aid of a circular graduated scale fitted to each gear, which can be used to set a new "zero" or starting point for the unit, or perhaps by changing the transmission link wholly or in part.

[0013] However, this operation inevitably dictates a stoppage that may keep the machine idle for some considerable time and in consequence can have a negative impact on its overall productivity each time the need for such a changeover happens to arise.

[0014] Accordingly, the object of the invention is to provide a machine for the automated manufacture of filter bags containing infusible substances, designed in such a way that the output per unit of time and the ultimate packaging format can be changed automatically without the machine itself having to stand still for prolonged periods and with no need for mechanical adjustments to be made directly to any of its component parts, beyond the obvious replacement of machine units or assemblies directly influenced by the shape and site of the bag, namely the dispenser, heat seal rollers etc.; instead, both the angular position of the shafts driving the various machine units and the absolute position in space of said machine units are controlled directly in such a manner that the motors can be retimed in a few moments and the operating cycle of the machine restarted without delay.

[0015] The stated object is realized according to the present invention as disclosed in claim 1.

[0016] The invention will now be described in detail, by way of example, with the aid of the accompanying drawings, in which:

- fig 1 illustrates a machine according to the present invention for the automated manufacture of filter bags containing infusible substances, seen in a general schematic elevation;
- fig 2 illustrates the succession of steps involved in fashioning a filter bag using the machine of fig 1, starting from a strip of filter paper and terminating with the emergence of a single bag, viewed partly in plan and partly in a side elevation;
- fig 3 is a block diagram of the elements making up the control system to which the drives of the machine disclosed are interlocked;
- fig 4 is an enlarged detail of the machine shown in fig 1, illustrating the manner in which longitudinal and transverse cutters and a stacking station are connected to respective drives, viewed schematically and in elevation with certain parts omitted better to reveal others.

[0017] As discernible from the accompanying draw-

ings, and in particular fig 2, the present invention relates to an automatic machine for the continuous production of filter bags 1 containing an infusible substance (typically tea leaves, camomile flowers, etc.).

[0018] The bag 1 (see fig 2) is of the type fashioned from two breasted strips 2 and 3 of filter paper enveloping a measure 4 of the substance and heat sealed together at the edges. Fig 2 shows a continuous strip of such bags 1 which in the particular example illustrated are generated in pairs two abreast by the various units of the machine for reasons concerned purely with output, albeit the principle clearly would stay the same were the bags to be generated in a single file utilizing two narrower strips: in short, the inventive concept underlying the machine remains unaffected.

[0019] The machine in question incorporates a succession of stations (see fig 1) arranged along a horizontal pass line indicated by the arrow denoted A.

[0020] Located first in sequence along the pass line A is a station 5 at which a continuous film F of filter paper is decoiled from a bulk roll 6 secured to a freely revolving pivot 37; the film can be fed initially in one piece and then divided as in the example of the drawings, or alternatively, two separate rolls might be utilized.

[0021] The decoiling film F is directed by way of transfer rollers 38 toward longitudinal cutting means 7, shown in the drawings as a circular cutter 7c anchored to a fixed structure 36 of the machine, and divided into two films F2 and F3 of identical width that will be heat sealed together ultimately to fashion the bag 1 (as discernible from fig 2).

[0022] Thereafter, the first strip 2 or first film F2 is directed into a second station 8 from which measures 4 of the infusible substance are dispensed through the agency of metering means 9 embodied as a revolving drum 39 and set in motion by a relative motor 8m; the measures 4 are deposited pair by pair in succession on the advancing strip 2, two abreast (see fig 2). The drum 39 in turn receives the substance from a hopper unit 40 (conventional in embodiment and therefore illustrated only in part) mounted above and connected to the drum.

[0023] Following the longitudinal cut, the second strip 3 or second film F3 advances toward the second station 8, which it joins at a given point beyond the revolving drum 39: in practice the second strip 3 is caused to bypass the second station 8, being diverted instead through transfer means 10 afforded by a set of idle rollers 10r positioned above the drum 39, thereafter descending and covering the first strip 2 with the measures 4 already in place.

[0024] The two joined strips 2 and 3 advance toward a third station 11 at which they are heat sealed together in the longitudinal and transverse directions. This third station comprises a pair of contrarotating rollers 11a and 11b set in motion by a drive comprising a single motor 11m and a timing belt 41; the two rollers 11a and 11b present a contoured and heated contact surface (conventional in embodiment and therefore indicated only in

part) such as will seal a peripheral area of the strips 2 and 3 circumscribing each measure 4 (the outline will be selected on the basis of packaging and marketing requirements) and thus generate a plurality of single bags 1, still united in a continuous strip and advancing in pairs two abreast (as indicated to advantage in fig 2).

[0025] Referring to fig 1, the two contrarotating rollers 11a and 11b are mounted overhung, each rotatable about a pivot coinciding with the relative horizontal axis of rotation, denoted 11ay and 11by. The pivots 11ay and 11by are associated permanently, to the front of the machine, with relative moving arms 42 associated in their turn at the rear of the machine with respective ends of a pair of rods 25 and 26; the two rods combine to create a toggle mechanism 27, connected pivotably to the end of a pneumatic actuator 28 (a cylinder in practice) disposed horizontally and anchored to the aforementioned fixed structure 36, by which the two rollers 11a and 11b can be drawn together and spread apart respectively at the start of a cycle and when the cycle is interrupted, in response to control media that will be described more fully in due course.

[0026] Continuing along the pass line beyond the heat seal rollers 11a and 11b, the advancing strip of bags 1 is cut longitudinally at a sixth station 12 through the agency of a second circular cutter 13 and divided into two halves, with the result that two parallel files of bags 1 are generated (the numbering of the stations is derived from the chronology of the appended claims, hence the slight discrepancy in terms of descriptive sequence when reading the specification).

[0027] More exactly, the second longitudinal cutter 13 (see figs 1 and 4) is positioned beneath the pass line A followed by the continuous strip of bags 1, whilst the station 12 also comprises a reaction wheel 29 located above the cutter 13 and the strip, mounted rotatably to a block 30 secured to the fixed structure 36 of the machine. 29a denotes a pair of pinch wheels positioned immediately preceding the cutter 13.

[0028] The strip of bags 1 (not separated longitudinally as yet) can be restrained by means of a clamp element 31 located between the two wheels 29 and 29a and anchored to the selfsame block 30, of which the operative end portion is capable of movement vertically between an inactive raised position, distanced from the strip in such a manner as to allow its advance, and an active lowered position of stable contact in which the strip is prevented both from advancing any further and from returning toward the third station 11 in the event of the operating cycle being interrupted.

[0029] Once beyond the sixth station 12, the two continuous strips of bags 1 are severed transversely at a fourth station 14 comprising a first cutter 15, consisting in a roller 15r fitted with a double edged blade, in such a way as to generate the discrete bags (see fig 2); the cutter 15 is driven by a relative motor 14m, which also transmits rotation to the second cutter 13 by way of a further timing belt 14c.

[0030] The cut bags 1 are collected and stacked at a fifth station 16 through the agency of means 17 by which the stacks are formed according to subsequent packaging requirements and in predetermined number.

[0031] More exactly, the means 17 in question are embodied as a vertical duct 32 with open top and bottom ends by which the single bags 1 are accommodated two abreast, one on top of another (creating a pair of stacks P1 and P2 each composed of single bags), and supported initially on two bearers 48 before dropping down onto a movable platform denoted 33.

[0032] It is by these two bearers 48, disposed one on either side of the duct 32, that the bags 1 are divided and sorted into the number per relative stack P1 and P2 required to make up the final package. The bearers 48 are essentially C-shaped, and positioned facing one another with the active top finger ends insertable through respective slots afforded by the walls of the duct 32; the bottom ends are pivotably associated with a support 49 which is secured in its turn to a belt 50 driven by a further motor 48m, in such a way that the bearers 48 can be set in motion along the duct 32.

[0033] The bearers 48 are designed to spread apart and draw together respectively into open and closed positions, utilizing the pivotable association mentioned above (see fig 4): anchored by their bottom ends to the piston rod 48a of a vertically disposed actuator 48p associated rigidly with the support 49, the bearers 48 can be distanced from one another by the actuator 48p (as illustrated in fig 4) when the stack of bags 1 is due to drop onto the platform 33, then drawn together to create a temporary second platform above and thus separate the stacked bags 1, already deposited on the movable platform 33 and descending toward the bottom of the duct 32, from the cut bags continuing to enter above and destined to make up the next package.

[0034] The platform 33 is capable of ascending and descending movement within the duct 32, its operation timed in relation to the opening and closing movement of the bearers 48 in such a way that bags 1 can be assembled in the numbers required for subsequent packaging steps at other stations.

[0035] To obtain this same ascending and descending movement, the platform 33 is rigidly associated with a support element 43 capable of sliding along a rod 44 anchored to the fixed structure 36 of the machine; the support element 43 is set in motion by way of a lever arm 45 pivotably associated at one end with the element and at the opposite end with the fixed structure 36, and coupled also to a crank mechanism comprising a rod 46 of which one is anchored to a slot 45a afforded by the arm 45 and the remaining end to a wheel 47 driven by a motor denoted 16m. In this way, the arm 45 is invested with alternating motion and the platform 33 supporting the bags 1 will rise and fall with each revolution of the power driven wheel 47.

[0036] Each time the movable platform 33 reaches its lower travel limit, a diverter 51 located at the bottom of

the duct 32 directs the two stacks P1 and P2 of bags 1 in a horizontal direction toward the aforementioned packaging stations (not illustrated in the drawings, being conventional in embodiment and no more than incidental to the present invention).

[0037] The diverter 51 is set in motion by a rod 52 connected via a transmission link, denoted 53 in its entirety, to a cam 47c which is also connected to the motor 16m driving the platform in such a way that the diverter and platform 51 and 33 are permanently synchronized.

[0038] Located at the top end of the stacking station 16 is an arm 34 by which the bags 1 are directed forcibly into the duct 32; disposed transversely to the duct and anchored by way of a fulcrum pivot 35 to the fixed structure 36 of the machine, the arm 34 is caused to alternate in time with the movements of the remaining stations, being connected likewise to the motor 14m driving the first cutter 15, and to move in a vertical direction V in such a way that its free end 34a will impinge firmly on the bags 1 advancing from the first cutter 15, thus favouring and ensuring their correct entry into the duct 32.

[0039] The main machine units at the majority of the stations described thus far, and in particular the dispensing station 8, the heat seal station 11, the transverse cutting station 14 and the stacking station 16, are driven by dedicated motors, i.e. 8m, 11m, 14m and 16m respectively, also 48m in the case of the bearers 48; each motor operates both independently of and in timed coordination with the remainder, providing e.m.f. for a respective machine axis 8x, 11x, 14x, 16x and 48x of which the angular position is controlled electrically.

[0040] In other words, each single axis 8x, 11x, 14x, 16x and 48x performing a given work cycle in the machine is controlled independently in respect of predetermined operating parameters (described in due course) by way of elements connected directly and indirectly to the movement of the selfsame axis.

[0041] More exactly, one of these electrically controlled axes, and in particular the axis 14x driving the first or transverse cutter 15, provides the master axis to which all remaining axes are referred: in this way, it becomes possible to establish operating parameters for the start of the cycle or for changing these selfsame parameters during the cycle.

[0042] All axes of the machine, the term "axis" signifying the electric motor together with the unit 8g, 11g, 14g, 16g and 48g by which its operation is controlled (as indicated in the diagram of fig 3) are interlocked to a monitoring and control unit 21 (e.g. utilizing printed circuit modules) such as will keep track of their angular positions one relative to another on the basis of variable operating parameters, i.e. the type of cycle adopted in manufacture of the filter bags 1, the number of bags per package, also the pattern and size of the single bag.

[0043] To this end, still referring to fig 3, each axis 8x, 11x, 14x, 16x and 48x is equipped with respective first means 18 (typically conventional encoders keyed directly to the relative motor shaft) by which to monitor the

position of the axis both as an angular value and in relation to the corresponding station 8, 11, 14, 16 and 48, also second means 19 (typically conventional proximity sensors connected indirectly to the relative motor shaft) by which to determine the absolute position in space of the machine components associated with the single axes 8x, 11x, 14x, 16x and 48x, i.e. the drum 39, heat seal rollers 11a and 11b, first cutter 15, platform 33 and bearers 48.

[0044] In short, each machine component is monitored in terms both of its expected position at a given moment in the context of the operating cycle, and of its prescribed absolute position in the light of the aforementioned operating parameters, which are pre-programmable by way of the monitoring and control unit 21.

[0045] As discernible from fig 3, the monitoring and control unit 21 might comprise one circuit module 22 for each one of the axes 8x, 11x, 14x, 16x and 48x, which will monitor and control the respective angular position on the basis of values Va and Va' received by the module from the first and second position sensing means 18 and 19, and of values Vb and Vb' derived from the master axis 14x. Alternatively, use could be made of multiple modules controlling a plurality of axes (i.e. depending on the design of the modules) as indicated in fig 3, where a single module 22 controls two axes.

[0046] In addition, the monitoring and control unit 21 will comprise means 23 by which to vary the speed of the master axis 14x and as a result obtain a simultaneous adjustment in speed of the subordinate axes driving the remaining stations of the machine, by virtue of their connection through the respective modules 22. To provide control over speed variations, the monitoring and control unit 21 is connected in turn to a unit 24 such as will display and allow manual or programmable changes to the variable operating parameters utilizing suitable software.

[0047] With a machine structured in this way, a manufacturer can bring about swift changes in the operating cycle without necessarily stopping the machine for lengthy periods to allow adjustments, and without any loss of control over the machine units as regards their normal operation. In the case of a straightforward variation in the operating speed and therefore the output of the machine, the act of simply entering a new output value gives place to a direct variation in the speed of the master motor; as a result, all of the modules 22 will take up the new value from the master and pilot the control unit of the connected motor (see arrows C in fig 3) to adjust and adapt the speed of the relative shaft to the new value. Again, in the slightly less simple case of a change to a new packaging format, for example with stacks P1 and P2 comprising a different number of bags, the relative combination is selected by way of the unit denoted 24; this then generates an instruction by way of the interlocked modules 22 to run the relative motors (16m and 48m in this instance) at new angular velocities such as will produce the new format. Accordingly, with

the various motors and the corresponding axes controlled electrically, changes of speed and format can be effected swiftly, with machine down times having very little influence on output.

[0048] The solution of first sensing means 18 keyed directly to the motor shafts is instrumental in enabling the monitoring and control unit to recognize the angular position of the relative machine axis at any given moment, whilst with second absolute position sensing means 19 applied preferably to the low speed axes or located along the trajectory of the components driven by them, the monitoring and control unit is able to establish the position in space of a given component without reference to the number of revolutions that must be completed by the shaft of the relative motor per operating cycle, i.e. information dependent upon the cycle.

[0049] Another example of the flexibility afforded by the machine disclosed is reflected in the ease with which the lines of the heat seal can be varied in relation to the subsequent transverse cut, so as to obtain a correct alignment between the heat seal and the cut; the operation is simple, and effected by way of the relative motor 11m. This same flexibility is similarly evident in the process whereby the measures 4 of the substance are dispensed onto the strip 2, inasmuch as the position of the measures in relation to the stroke made subsequently by the transverse cutter 15 can be altered by piloting a corresponding adjustment of the motor 8m which drives the dispensing means 9.

[0050] With machine units interlocked to an automatic control system as described and illustrated, positioning and timing adjustments can be made with a simplicity not afforded by prior art machines having all-mechanical transmission linkages. Furthermore, in the event of an interruption occasioned by a stall in the cycle or a change to a different style of bag 1, this is handled directly by the monitoring and control unit 21 which, when the machine restarts, will readjust the axes as required according to the relative position occupied by each one at the moment when the stoppage occurred, and according to the absolute position in the context of the operating cycle.

[0051] In addition, the opening and closing movement of the heat seal rollers 11a and 11b could be automated so as to prevent any damage to the strips 2 and 3 occupying the station 11 at the moment when a stoppage occurs.

[0052] As the rollers 11a and 11b open, the monitoring and control unit 21 will detect the movement and cause the clamp element 31 to descend, restraining the strips of bags 1 currently advancing through the longitudinal cut; these would otherwise be pulled back toward the heat seal rollers 11a and 11b and the already formed bags 1 consequently lost.

[0053] A further advantage afforded by the machine disclosed is that the components of one or more stations could be embodied as interchangeable modular assemblies and selected on the basis of the aforementioned

variable operating parameters. When changing to a different size of film F2 and F3 utilized for a given pattern of bag 1, for example, the heat seal rollers 11a and 11b might easily be released from the arms 42 and replaced with others; the arms thus provide means by which the assembly is associated removably with the respective electric motor 11m, this being a non-interchangeable part.

Claims

1. A machine for the automated manufacture of bags (1) containing infusible substances, in particular a bag of the type fashioned from two joined strips (2, 3) of filter paper enveloping at least one measure (4) of the substance, which comprises a plurality of stations ordered along a pass line (A) :

a first station (5) at which a first film (F2) of filter paper serving to establish a first strip (2) is decoiled from a roll (6) and directed toward a second station;

a second station (8) at which a measure (4) of the infusible substance is dispensed, onto the advancing first strip (2) by metering means (9) positioned along the pass line (A), and at which the selfsame first strip (2) is joined and covered at a point beyond the metering means (9) by a second film (F3) constituting the second strip (3);

a third station (11) at which the united strips (2, 3) are heat sealed longitudinally and transversely by a pair of contrarotating rollers (11a, 11b), thereby generating a continuous strip or bags (1) ordered in linear succession;

a fourth station (14) at which the continuous strip is divided by a first transverse cutter (15) into a plurality of discrete bags (1); and

a fifth station (16) at which bags (1) advancing from the fourth station (14) are taken up by stacking means (17) and allowed to accumulate in predetermined number as required for subsequent packaging;

at least the second, third, fourth and fifth stations (8, 11, 14, 16) being set in motion by drive means (8m, 11m, 14m, 16m) operating independently of and synchronously with one another, each identifiable as a relative machine axis (8x, 11x, 14x, 16x)

characterized in that:

each one of the machine axes (8x, 11x, 14x, 16x) is electrically controlled and is equipped with first means (18) by which to monitor the angular position of the axis in relation so the corresponding station (8, 11, 14, 16), and second means (19) by which to monitor the absolute position in space of

the machine units (9, 11a, 11b, 15, 17) set in motion by the respective axes (8x, 11x, 14x, 16x), the absolute position being a function of variable operating parameters programmable by way of the monitoring and control unit (21);

all the electrically controlled axes (8x, 11x, 14x, 16x) being interlocked to a monitoring and control unit (21) such as will verify their angular position one in relation to another on the basis of variable operating parameters, namely the number of bags (1) manufactured per unit of time, the number of bags per single package and the site and/or pattern of the individual bag;

at least one of the electrically controlled axes (8x, 11x, 14x, 16x) functions as a master axis to which all the remainder are subordinate.

2. A machine as in claim 1, wherein the bags (1) of the continuous strip are arranged in pairs, two abreast and ordered in linear succession: comprising a sixth station (12) located between the third and fourth stations (11, 14) and comprising a second cutter (13) by which the continuous strip is cut longitudinally into two parts in such a way as to create two parallel lines of bags advancing one alongside the other.
3. A machine as in claim 1, wherein the master axis (14x) to which the remaining axes are subordinated coincides with the drive means (14m) of the first transverse cutter (15) operating at the fourth station (14).
4. A machine as in claim 1, wherein the monitoring and control unit (21) comprises one circuit module (22) governing each of the electrically controlled axes (8x, 11x, 16x) subordinate to the master axis (14x), such as will monitor and control the angular position of the corresponding axis on the basis of values (Va, Va') received by the module from the first and second position sensing means (18, 19), and of values (Vb, Vb') generated by the master axis (14x).
5. A machine as in claim 1, wherein the monitoring and control unit (21) comprises one circuit module (22) governing at least two of the electrically controlled axes (8x, 11x, 16x) subordinate to the master axis (14x), such as will monitor and control the angular position of the corresponding axes on the basis of values (Va, Va') received by the module from the first and second position, sensing means (18, 19), and of values (Vb, Vb') generated by the master axis (14x).
6. A machine as in claim 1, wherein the monitoring and control unit (21) comprises means (23) by which to vary the operating speed at least of the master axis (14x), and is connected also to a unit (24) such as

will both display and allow manual or programmable changes to the variable operating parameters.

7. A machine as in claim 1, wherein the first station (5) comprises a roll (6) from which a single film (F) is decoiled and divided successively into two parts (F2, F3) by longitudinal cutting means (7) to create the two strips (2, 3), of which the part (F3) providing the second strip (3) is caused to by-pass the second station (8) through the agency of transfer means (10) and joined thereafter to the first strip (2) at a given point on the pass line (A) beyond the metering means (9).
8. A machine as in claim 1, wherein any one or any number of the stations (5, 8, 11, 14, 16) comprises machine units (6, 9, 11a, 11b, 15, 17) consisting in modular assemblies that are interchangeable according to the variable operating parameters and associated removably with the relative electric drive means (8m, 11m, 14m, 16m), which are non-interchangeable.
9. A machine as in claim 1, wherein the rollers (11a, 11b) of the third station (11) are contrarotatable about respective horizontal axes (11ay, 11by) and disposed one above the other, each associated at the rear of the machine with respective ends of a pair of rods (25, 26) combining to create a toggle mechanism (27) connected pivotably to one end of a horizontally disposed pneumatic actuator (28) by which the two rollers (11a, 11b) can be drawn together and spread apart, in response to a command from the monitoring and control unit (21), respectively at the start of a cycle and when the cycle is interrupted.
10. A machine as in claim 2, wherein the continuous strip of bags (1) is divided longitudinally by a second cutter (13) located beneath a pass line (A) followed by the strip, directly under at least one reaction wheel (29) mounted rotatably to a block (30) secured to the machine above the pass line (A), and the sixth station (12) further comprises a clamp element (31) occupying a position following the reaction wheel (29) and preceding the cutter (13) relative to the pass line, anchored slidably to the block (30) and capable of movement vertically between an inactive raised position, distanced from the strip in such a manner as to allow its advance, and an active lowered position of contact assumed in response to a command from a monitoring and control unit (21) in the event of the operating cycle being interrupted, whereby the strip is prevented both from advancing any further and from returning toward the third station (11).
11. A machine as in claim 1, wherein stacking means

(17) at the fifth station (16) consist in at least one vertical duct (32) with open top and bottom ends designed to accommodate the single bags (1) one on top of another and resting on a platform (33) located within and capable of movement along the duct (32), into which the bags (1) are directed forcibly by an arm (34) disposed transversely and adjacent to the open top and, anchored by way of a fulcrum pivot (35) to a fixed structure (36) of the machine and capable thus of alternating movement synchronously with the movements of the remaining stations and in a vertical direction (V), in such a way that its free end (34a) will enter into contact with the bags (1) advancing from the fourth station (14) and favour their entry into the duct (32).

Patentansprüche

1. Vorrichtung zum automatischen Herstellen von Beuteln (1) enthaltend eine aufgiessbare Substanz, insbesondere von einem Beutel vom Typ aus zwei zusammengefügteten Streifen (2, 3) von Filterpapier, die wenigstens eine Dosis (4) der Substanz einschliessen, welche Vorrichtung eine Anzahl von entlang einer Vorlaufbahn (A) angeordnete Stationen enthält:
 - eine erste Station (5), an welcher eine erste Folie (F2) von Filterpapier, die den ersten Streifen (2) bildet, von einer Spule (6) abgewickelt und zu einer zweiten Station geleitet wird;
 - eine zweite Station (8), an welcher eine Dosis (4) der aufgiessbaren Substanz auf den vorlaufenden ersten Streifen (2) abgegeben wird, und zwar durch Dosiermittel (9), die entlang der Vorlaufbahn (A) angeordnet sind, und an welcher derselbe erste Streifen (2) an einem Punkt im Anschluss an die Dosiermittel (9) von einer den zweiten Streifen (3) bildenden zweiten Folie (F3) erreicht und von dieser abgedeckt wird;
 - eine dritte Station (11), an welcher die zusammengefügteten Streifen (2, 3) in Längsrichtung und in Querrichtung durch ein Paar von sich entgegengesetzt drehenden Rollen (11a, 11b) heissversiegelt werden, wobei ein kontinuierlicher Streifen von in linearer Folge geordneten Beuteln (1) hergestellt wird;
 - eine vierte Station (14), an welcher der kontinuierliche Streifen durch ein erstes Schneidwerkzeug (15) zum Querschneiden in eine Anzahl von einzelnen Beuteln (1) getrennt wird; und
 - eine fünfte Station (16), an welcher die aus der vierten Station (14) vorlaufenden Beutel (1) durch Stapelmittel (17) aufgenommen werden, welche das Stapeln in einer zum anschliessenden Verpacken erforderlichen Zahl erlauben;
2. Vorrichtung nach Patentanspruch 1, bei welcher die Beutel (1) des kontinuierlichen Streifens paarweise nebeneinander liegend und in linearer Folge angeordnet sind; enthaltend eine sechste Station (12), angeordnet zwischen der dritten und der vierten Station (11, 14) und enthaltend ein zweites Schneidwerkzeug (13), durch welches der kontinuierliche Streifen in Längsrichtung auf solche Weise in zwei Teile getrennt wird, dass zwei parallele und nebeneinander liegende Reihen von vorlaufenden Beuteln erzeugt werden.
3. Vorrichtung nach Patentanspruch 1, bei welcher die Bezugsachse (14x), welcher die verbleibenden Achsen untergeordnet sind, mit den Antriebsmittel (14m) des ersten Schneidwerkzeugs (15) für den Querschnitt übereinstimmt, das an der vierten Station (14) arbeitet.
4. Vorrichtung nach Patentanspruch 1, bei welcher die Überwachungs- und Steuereinheit (21) ein Schaltmodul (22) enthält, welches jede der elektrisch gesteuerten und der Bezugsachse (14x) untergeordneten Achsen (8x, 11x, 16x) auf solche Weise verwaltet, dass die Winkelposition der entsprechenden Achse überwacht und gesteuert wird, und zwar auf der Basis von Werten (Va, Va'), die von dem Modul

seitens der ersten und zweiten Positionsabtaster (18, 19) empfangen wurden, sowie von Werten (Vb, Vb'), die von der Bezugsachse (14x) erzeugt wurden.

5. Vorrichtung nach Patentanspruch 1, bei welcher die Überwachungs- und Steuereinheit (21) ein Schaltmodul (22) enthält, welches wenigstens zwei der elektrisch gesteuerten und der Bezugsachse (14x) untergeordneten Achsen (8x, 11x, 16x) auf solche Weise verwaltet, dass die Winkelposition der entsprechenden Achse überwacht und gesteuert wird, und zwar auf der Basis von Werten (Va, Va'), die von dem Modul seitens der ersten und zweiten Positionsabtaster (18, 19) empfangen wurden, sowie von Werten (Vb, Vb'), die von der Bezugsachse (14x) erzeugt wurden.
6. Vorrichtung nach Patentanspruch 1, bei welcher die Überwachungs- und Steuereinheit (21) Mittel (23) enthält, durch welche die Betriebsgeschwindigkeit von wenigstens der Bezugsachse (14x) verändert werden kann, und die auch an eine Einheit (24) angeschlossen ist, durch welche die Sichtbarmachung und der manuelle oder programmierbare Wechsel der variablen Betriebsparameter erlaubt ist.
7. Vorrichtung nach Patentanspruch 1, bei welcher die erste Station (5) eine Spule (6) enthält, von welcher eine einzelne Folie (F) abgewickelt und anschließend durch Schneidmitteln (7) für den Längsschnitt in zwei Teile (F2, F3) geteilt wird, um zwei Streifen (2, 3) zu erzeugen, von welchen der den zweiten Streifen (3) bildende Teil (F3) durch die Wirkung von Umlenkmitteln (10) an der zweiten Station (8) vorbei geführt und dann an einem bestimmten Punkt an der Vorlaufbahn (A) im Anschluss an die Dosiermittel (9) mit dem ersten Streifen (2) zusammengefügt wird.
8. Vorrichtung nach Patentanspruch 1, bei welcher eine jede oder eine Anzahl der Stationen (5, 8, 11, 14, 16) Betriebseinheiten (6, 9, 11a, 11b, 15, 17) enthält, die aus Baukastengruppen bestehen, die je nach den variablen Betriebsparametern austauschbar und lösbar mit den jeweiligen elektrischen Antriebsmitteln (8m, 11m, 14m, 16m) verbunden sind, diese wiederum nicht austauschbar.
9. Vorrichtung nach Patentanspruch 1, bei welcher die Rollen (11a, 11b) der dritten Station (11) gegeneinander um jeweilige horizontale Achsen (11ay, 11by) drehbar und eine über der anderen angeordnet sind, jede an der Rückseite der Vorrichtung entsprechenden Enden von einem Paar von Stangen (25, 26) zugeordnet, die zusammen ein Kniehebelgetriebe (27) bilden, das drehbar an ein Ende von

einem horizontal angeordneten Drucklufttrieb (28) angeschlossen ist, durch welchen die beiden Rollen (11a, 11b) auf einen Befehl der Überwachungs- und Steuereinheit (21) hin einander genähert und voneinander entfernt werden können, und zwar jeweils bei Beginn eines Zyklus und wenn der Zyklus unterbrochen wird.

10. Vorrichtung nach Patentanspruch 2, bei welcher der kontinuierliche Streifen von Beuteln (1) in Längsrichtung durch ein zweites Schneidwerkzeug (13) getrennt wird, das unterhalb einer der von dem Streifen durchlaufenen Vorlaufbahn (A) angeordnet ist, und zwar direkt unter wenigstens einer Gegen- druckrolle (29), die drehbar an einem oberhalb der Vorlaufbahn (A) an der Vorrichtung befestigten Block (30) montiert ist, und bei welcher die sechste Station (12) weiter ein Klemmelement (31) enthält, das eine Position im Anschluss an die Gegendruck- rolle (29) einnimmt und im Verhältnis zu der Vorlauf- bahn dem Schneidwerkzeug (13) vorausgeht, gleit- bar an dem Block (30) befestigt und in der Lage ist, sich vertikal zwischen einer nicht aktiven, angeho- benen Position, in welcher es auf solche Weise von dem Streifen entfernt ist, dass es seinen Vorlauf er- laubt, und einer aktiven, gesenkten Position des Kontaktes zu bewegen, die als Antwort auf einen Befehl der Überwachungs- und Steuereinheit (21) für den Fall eingenommen wird, dass der Betriebs- zyklus unterbrechen sollte, wodurch der Streifen am weiteren Vorlauf und am Rücklauf zu der dritten Station (11) gehindert wird.
11. Vorrichtung nach Patentanspruch 1, bei welcher die Stapelmittel (17) an der fünften Station (16) aus wenigstens einem vertikalen Kanal (32) mit offenen oberen und unteren Enden bestehen, der dazu be- stimmt ist, die einzelnen Beutel (1) einen über dem anderen aufzunehmen, wobei diese auf einer Platt- form (33) liegen, welche innerhalb des Kanals (32) angeordnet ist und sich entlang diesem bewegen kann, und in welchen die Beutel (1) zwangsläufig durch einen Arm (34) geleitet werden, der quer und an das obere Ende angrenzend angeordnet ist, ver- ankert mit Hilfe eines Drehzapfens (35) an einer feststehenden Struktur (36) der Vorrichtung und in der Lage, eine wechselweise Bewegung in vertikaler Richtung (V) synchron mit den Bewegungen der verbleibenden Stationen auszuführen, und zwar auf solche Weise, dass sein freies Ende (34a) in Kontakt mit den aus der vierten Station (14) vorlau- fenden Beuteln (1) gelangt und deren Eintritt in den Kanal (32) erleichtert.

Revendications

1. Une machine pour la fabrication automatisée de sa-

chets (1) contenant des substances à infuser, en particulier un sachet du type réalisé à partir de deux bandes jointes (2, 3) de papier filtre enveloppant au moins une dose (4) de la substance, qui comprend

une première station (5) au niveau de laquelle un premier film (F2) de papier filtre constituant une première bande (2) est déroulé d'une bobine (6) et dirigé vers une deuxième station ; une deuxième station (8) au niveau de laquelle une dose (4) de la substance à infuser est distribuée sur la première bande (2) qui avance par des moyens de dosage (9) positionnés le long de la ligne d'avancement (A), et au niveau de laquelle cette même première bande (2) est rejointe et recouverte en un point situé au-delà des moyens de dosage (9) par un deuxième film (F3) constituant la deuxième bande (3) ; une troisième station (11) au niveau de laquelle les bandes (2, 3) réunies sont thermoscellées longitudinalement et transversalement par une paire de rouleaux contre-rotatifs (11a, 11b), définissant ainsi une bande continue de sachets (1) disposés l'un à la suite de l'autre ; une quatrième station (14) au niveau de laquelle la bande continue est divisée par un premier couteau transversal (15) en une série de sachets unitaires (1) ; et une cinquième station (16) au niveau de laquelle les sachets (1) qui sortent de la quatrième station (14) sont prélevés par des moyens d'empilage (17) et s'accumulent selon un nombre prédéterminé en fonction de leur conditionnement successif ; au moins la deuxième, troisième, quatrième et cinquième stations (8, 11, 14, 16) étant mues par des moyens d'actionnement (8m, 11m, 14m, 16m) fonctionnant indépendamment et en synchronisation avec les autres, chacun d'eux étant identifiable comme un axe opérationnel correspondant (8x, 11x, 14x, 16x) ;

ladite machine étant **caractérisée en ce que** chacun des axes opérationnels (8x, 11x, 14x, 16x) est commandé électriquement et est équipé de premiers moyens (18) destinés à contrôler la position angulaire de l'axe par rapport à la station correspondante (8, 11, 14, 16), et de deuxièmes moyens (19) destinés à contrôler la position absolue dans l'espace des unités opérationnelles (9, 11a, 11b, 15, 17) actionnées par les axes respectifs (8x, 11x, 14x, 16x), la position absolue étant une fonction des paramètres de fonctionnement variables programmables par l'intermédiaire d'une unité de contrôle et de commande (21) ; tous les axes à commande électrique (8x, 11x, 14x, 16x) étant asservis à l'unité de

contrôle et de commande (21) destinée à vérifier leur position angulaire l'un par rapport à l'autre en fonction des paramètres de fonctionnement variables, à savoir, le nombre de sachets (1) fabriqués par unité de temps, le nombre de sachets par boîte de conditionnement et le format et/ou type du sachet unitaire ; au moins l'un des axes à commande électrique (8x, 11x, 14x, 16x) servant d'axe maître auquel sont subordonnés tous les autres axes.

2. La machine selon la revendication 1, où les sachets (1) de la bande continue sont arrangés deux par deux de front, les uns à la suite des autres, **caractérisée en ce qu'elle** comprend une sixième station (12) située entre les troisième et quatrième stations (11, 14) et comprenant un deuxième couteau (13) destiné à couper longitudinalement la bande continue en deux parties pour définir deux lignes parallèles de sachets avançant l'une à côté de l'autre.
3. La machine selon la revendication 1, **caractérisée en ce que** l'axe maître (14x) auquel sont subordonnés les autres axes coïncide avec les moyens d'actionnement (14m) du premier couteau transversal (15) fonctionnant au niveau de la quatrième station (14).
4. La machine selon la revendication 1, **caractérisée en ce que** l'unité de contrôle et de commande (21) comprend un module à circuits (22) pilotant chacun des axes à commande électrique (8x, 11x, 16x) subordonnés à l'axe maître (14x), et destiné à contrôler et commander la position angulaire des axes correspondants en fonction de valeurs (Va, Va') envoyées à ce même module par les premiers et deuxièmes moyens (18, 19) de détection de la position, et en fonction de valeurs (Vb, Vb') générées par l'axe maître (14x).
5. La machine selon la revendication 1, **caractérisée en ce que** l'unité de contrôle et de commande (21) comprend un module à circuits (22) pilotant au moins deux des axes à commande électrique (8x, 11x, 16x) subordonnés à l'axe maître (14x), et destiné à contrôler et commander la position angulaire des axes correspondants en fonction de valeurs (Va, Va') envoyées à ce même module par les premiers et deuxièmes moyens (18, 19) de détection de la position, et en fonction de valeurs (Vb, Vb') générées par l'axe maître (14x).
6. La machine selon la revendication 1, **caractérisée en ce que** l'unité de contrôle et de commande (21) comprend des moyens (23) destinés à faire varier la vitesse opérationnelle d'au moins l'axe maître (14x), et est également reliée à une unité (24) qui affichera et permettra d'apporter des changements manuels ou programmables aux paramètres de

fonctionnement variables.

7. La machine selon la revendication 1, **caractérisée en ce que** la première station (5) comprend une bobine (6) à partir de laquelle un film unitaire (F) est déroulé puis divisé en deux parties (F2, F3) par des moyens de coupe longitudinale (7) pour définir les deux bandes (2, 3), dont la partie (F3) constituant la deuxième bande (3) est déviée de la deuxième station (8) par l'intermédiaire de moyens de transfert (10) pour venir rejoindre la première bande (2) en un point donné de la ligne d'avancement (A) au-delà des moyens de dosage (9). 5
8. La machine selon la revendication 1, **caractérisée en ce qu'**une ou plusieurs des stations (5, 8, 11, 14, 16) comprend des unités opérationnelles (6, 9, 11a, 11b, 15, 17) consistant en groupes modulaires qui sont interchangeables en fonction des paramètres de fonctionnement variables et sont associés de manière amovible aux moyens d'actionnement électriques correspondants (8m, 11m, 14m, 16m), ces derniers n'étant pas interchangeables. 10
9. La machine selon la revendication 1, **caractérisée en ce que** les rouleaux (11a, 11b) de la troisième station (11) peuvent tourner en sens de rotation contraire autour de leur axe horizontal (11ay, 11by) respectif et sont placés l'un au-dessus de l'autre, associés chacun à l'arrière de la machine avec les extrémités respectives d'une paire de tiges (25, 26) qui se combinent pour définir un mécanisme de bascule (27) relié de manière pivotante à une extrémité d'un actionneur pneumatique (38) placé à l'horizontale, destiné à rapprocher ou éloigner les deux rouleaux (11a, 11b) l'un de l'autre, suite à une commande envoyée par l'unité de contrôle et de commande (21), respectivement, au début d'un cycle et lors d'une interruption du cycle. 25
10. La machine selon la revendication 2, **caractérisée en ce que** la bande continue de sachets (1) est divisée longitudinalement par un deuxième couteau (13) situé au-dessous d'une ligne d'avancement (A) suivie par la bande, directement sous au moins un galet de contraste (29) monté de manière à pouvoir tourner sur un bloc (30) fixé à la machine au-dessus de la ligne d'avancement (A), et **en ce que** la sixième station (12) comprend également un élément de blocage (31) positionné après le galet de contraste (29) et avant le couteau (13) par rapport à la ligne d'avancement, ancré de manière coulissante au bloc (30) et pouvant se déplacer verticalement entre une position haute non opérationnelle, dans laquelle il est distancé de la bande de manière à permettre à cette dernière d'avancer, et une position basse opérationnelle dans laquelle il est en contact avec cette même bande et qu'il prend suite à une 30
- 35
- 40
- 45
- 50
- 55

commande envoyée par l'unité de contrôle et de commande (21) dans le cas d'une interruption du cycle de fonctionnement, empêchant ainsi la bande d'avancer ou de retourner vers la troisième station (11).

11. La machine selon la revendication 1, **caractérisée en ce que** les moyens d'empilage (17) de la cinquième station (16) sont constitués par au moins un conduit vertical (32), ouvert aux extrémités supérieure et inférieure, destinés à recevoir les sachets unitaires (1) l'un sur l'autre et en appui sur un plan (33) situé à l'intérieur et pouvant se déplacer le long de ce même conduit (32), dans lequel les sachets (1) sont forcés à entrer par un bras (34) transversal et adjacent à l'extrémité supérieure ouverte, ancré au moyen d'un pivot (35) à une structure fixe (36) de la machine et pouvant ainsi se déplacer par mouvement alternatif, en synchronisation avec les mouvements des autres stations, dans une direction verticale (V), de manière à ce que son extrémité libre (34a) vienne en contact avec les sachets (1) sortant de la quatrième station (14) et favorise leur introduction dans le conduit (32).

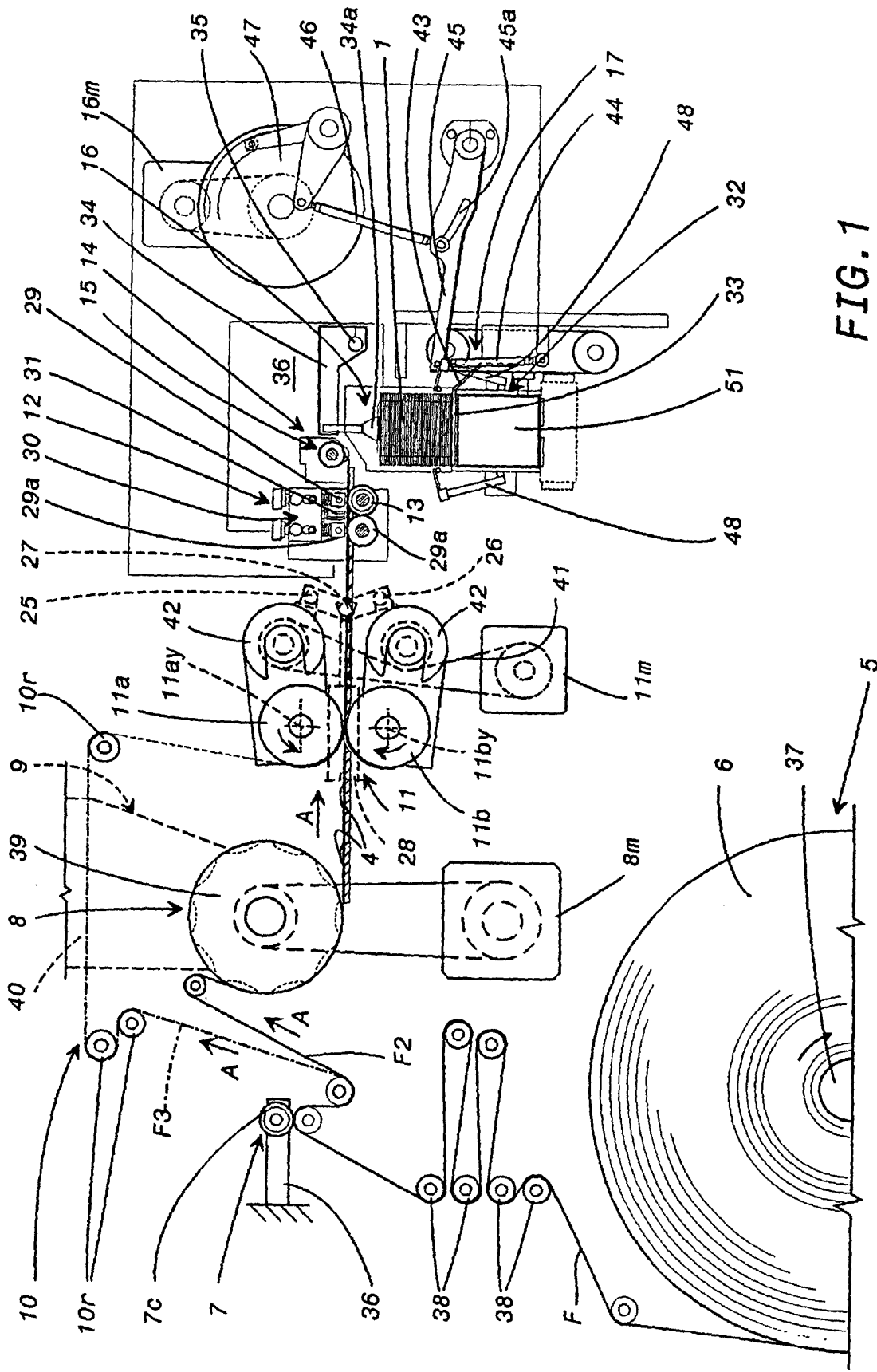

FIG. 1

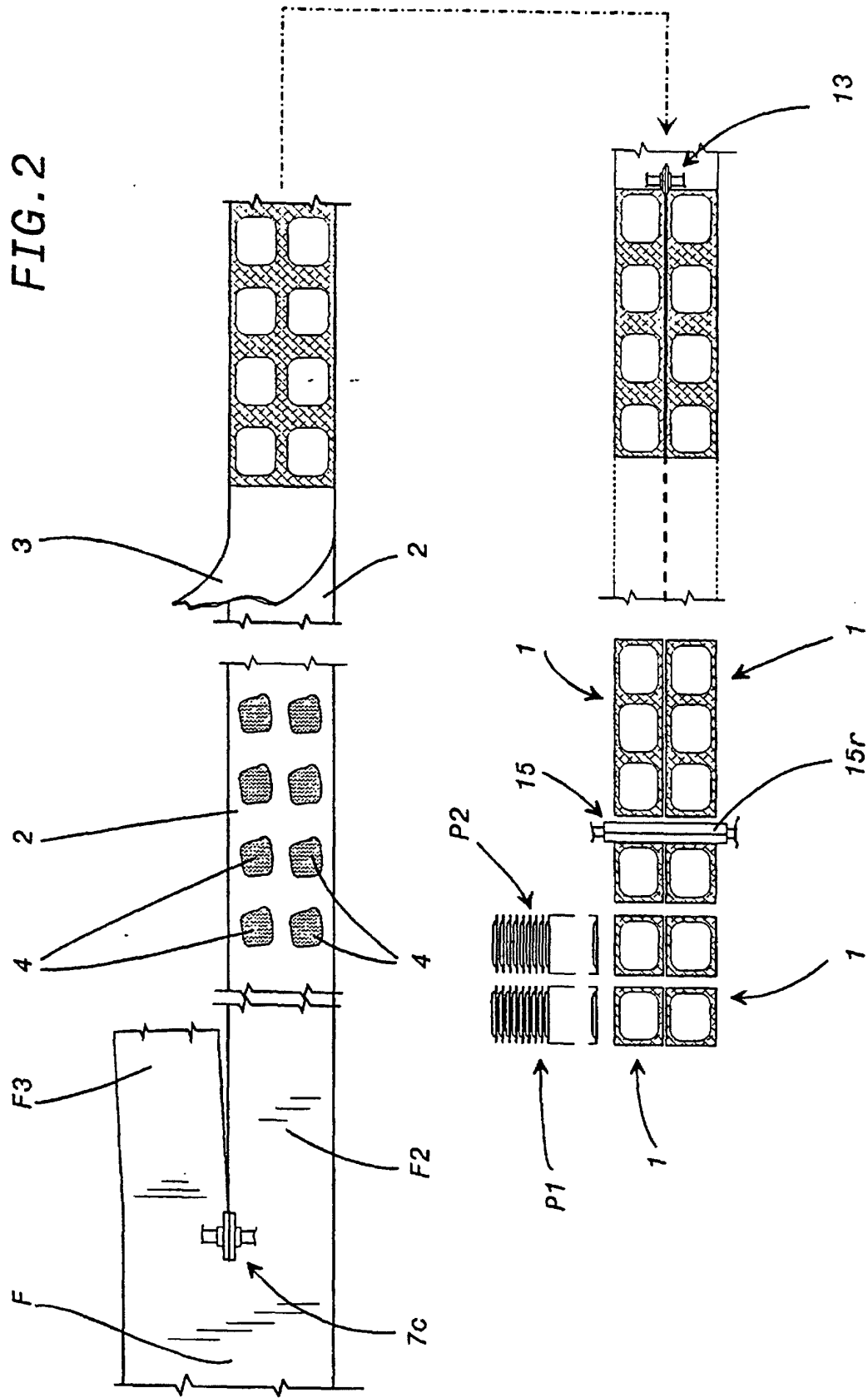

FIG. 3

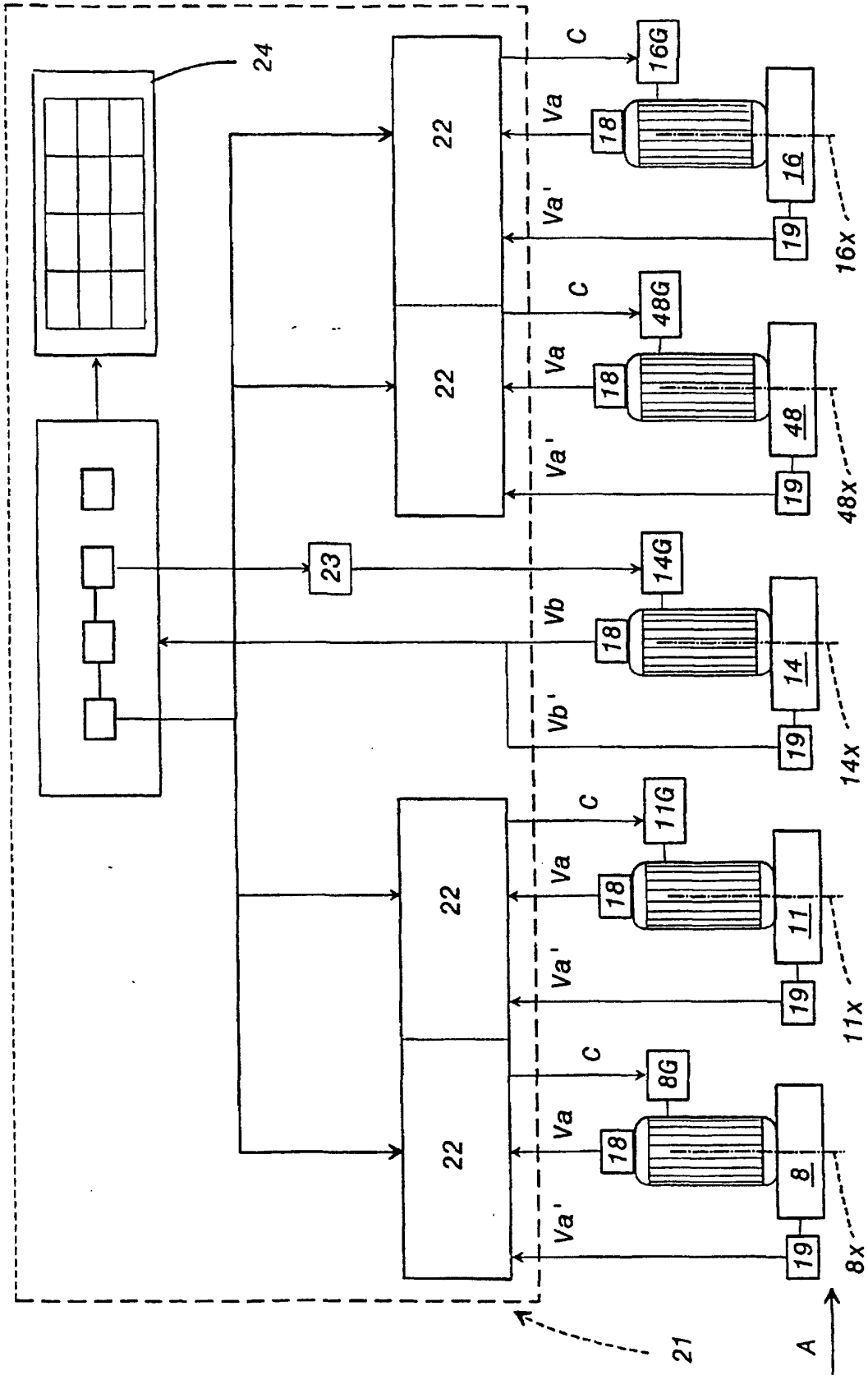

FIG. 4

