

(19)



Europäisches Patentamt
European Patent Office
Office européen des brevets



(11)

EP 0 806 511 B1

(12)

EUROPEAN PATENT SPECIFICATION

(45) Date of publication and mention
of the grant of the patent:
21.10.1998 Bulletin 1998/43

(51) Int Cl.⁶: **D06B 23/20**

(21) Application number: **96107052.1**

(22) Date of filing: **04.05.1996**

(54) **Textile dyeing machines of the overflow or jet type mounted in series or in parallel**

Für Einzel- oder Parallelbetrieb ausgerüstete Maschinen zum Färben von Textilien

Machines pour la teinture des textiles équipées pour fonctionner en série ou en parallèle

(84) Designated Contracting States:
CH DE ES FR GB GR IT LI PT

(56) References cited:
US-A- 5 228 318

(43) Date of publication of application:
12.11.1997 Bulletin 1997/46

- **PATENT ABSTRACTS OF JAPAN vol. 14, no. 143 (C-0703), 19 March 1990 & JP-A-02 014065 (TOYOBO CO. LTD.)**

(73) Proprietor: **PAGGI Srl**
20083 Vigano di Gaggiano, Milano (IT)

- **DATABASE WPI Section Ch, Week 8420 Derwent Publications Ltd., London, GB; Class F06, AN 84-123674 XP002015764 & JP-A-59 059 966 (JAPAN SENSHOKU KIKAI KK; OZAWA SENKO KK)**

(72) Inventor: **Paggi, Roberto**
20123 Milano (IT)

(74) Representative: **de Pasquale, Carlo**
Via Carlo Ravizza 53
20149 Milano (IT)

EP 0 806 511 B1

Note: Within nine months from the publication of the mention of the grant of the European patent, any person may give notice to the European Patent Office of opposition to the European patent granted. Notice of opposition shall be filed in a written reasoned statement. It shall not be deemed to have been filed until the opposition fee has been paid. (Art. 99(1) European Patent Convention).

Description

In the field of textile dyeing with machines of Overflow or Jet type, installing a certain number of machines in series is known.

By means of this system, one can define several operating configurations as a function of the amount of fabric to be dyed per each colour using some machines connected in cascade (this type of connection is called in parallel in common tinctorial language), and using other machines on individual basis.

For example, with four machines in series, the six following operating combinations can be obtained:

- all machines operating individually;
- the first two machines connected in parallel and the other two operating individually;
- the first two machines operating individually and the other two operating in parallel;
- two series of two machines, each operating in parallel;
- the first three machines operating in parallel and the fourth machine operating individually ;
- all machines operating in parallel.

The problem arising with the machines being so used derives from the need for completely mixing the dyeing bath which must be perfectly homogeneous in all machines operating in parallel, with the dyeing bath contained in each of machines operating in parallel having to be caused to flow also through the other machines which constitute the cascade of machines, in such a way that all dyeing baths are mixed with one another, thus rendering homogeneous the dye.

The system known from the prior art consists in transferring, by means of the same circulation pump of the dyeing bath of the machine which delivers the bath through the exchanger unit to the Overflow funnel or to the Jet, all the bath of a dyeing machine to the following, or preceding, dyeing machine, until the last machine operating in the parallel configuration receives the dyeing bath from the first machine of the cascade, and vice-versa, and so on, in continuous, throughout the dyeing time.

At present, in order to do so, the dyeing machines, for example, a series of four machines like those which are mentioned in the example set forth in the following, are connected with one another by means of a complex system of large diameter pipes, i.e., having a same diameter as of the flow or Jet duct, on which 26 automatic valves are installed in order to control the bath circulation according to the required path by the selected operating configuration; each valve is provided with a pneumatic, double-effect servocontrol unit which causes the valve to rotate by 90°. in both directions; each servocontrol unit must be provided with two limit switches in order to check that the valve is actually opened or closed, consequently with a total number of 52 limit

switches. Summing-up, in order to allow a known system consisting of four machines in series to operate in parallel mode, additionally to the inherently quite complex piping system, 26 valves, 26 servocontrol units and 52 limit switches are required.

Among other things, such a complex structure complicates also the electronic control unit which must control 26 valves and 52 limit switches with a rather complex logics, because many solenoid valves and relevant limit switches must be operated in different modes for each of the possible six configurations for in parallel operating mode.

A flow configuration interconnecting first and second textile dyeing machines such that dye circulated through the first dyeing machine is homogeneously intermixed with dye circulated through the second dyeing machine is disclosed in US-A-5 228 318.

Overcoming a kind of technical prejudice existing in this field as to the possibility of applying to textile dyeing processes an analogous system to the system used in skein or package yarn dyeing, by means of the present invention we thought of simplifying the muddled system of pipes and valves as described above.

The present invention consists in having separated the loop for mixing the bath of the several machines from the loop used for circulating the dyeing both inside each machine and in having used, for circulating the bath from a dyeing machine to another dyeing machine, a suitable pump of reversible type and having simply connected each tank of each dyeing machine to the tank of the immediately downstream dyeing machine by means of two pipes, wherein the one pipe is installed in a low position at tank bottom level, on which the pump and a valve are installed; and the other pipe being installed slightly under the maximal level reached by the dyeing bath inside the tank, and on which a second valve is installed.

The circulation pump for the dyeing bath of each dyeing machine is used in this case only to circulate the dyeing bath inside the same machine, by collecting it from the bottom of the tank and supplying it, through the exchanger unit, to the Overflow funnel or Jet.

For four machines installed in series, in this case only three connections of the above disclosed type are enough, and consequently: three pumps, six valves and simple pipe lengths which respectively connect mutually adjacent machines at the levels of their respective tank bottom and at a level which is slightly lower than the surface of the maximal level reached by the bath and namely: the first machine with the second machine, the second machine with the third machine and the third machine with the fourth machine, on each pipe length the following devices being installed: on the bottom pipe length, a reversible pump and a two-way valve and on the top pipe length a second two-way valve, with each valve being provided with a relevant pneumatic servocontrol unit and two limit switches.

It consequently occurs that the dyeing bath of each dyeing machine is collected by the pump from the bot-

tom of the tank and is sent to the tank of the downstream dyeing machine, so that on this second machine the level of the dyeing bath contained in its tank rises and, through the second, higher-level pipe, overflows into the tank of the preceding dyeing machine, and so forth, according to the desired operating combinations, as it is disclosed in greater detail in the following.

This procedure is performed during a certain time in a direction and is then reversed during a same time period, because the pumps are of reversible type.

By this system, one obtains, in a very simple and effective way, a complete homogenizing of the dyeing bath contained in all tanks in parallel also when all the dyeing machines are connected in this way.

The present invention will be better understood on the basis of the disclosure of an exemplifying embodiment supplied for merely exemplifying, non-limitative purpose, as illustrated by the accompanying figures, which represent:

Figure 1 shows a side view of a dyeing machine of Overflow type;

Figure 2 shows the front view of four dyeing machines of said type installed in series;

Figure 3 shows a top plan view of said four dyeing machines;

Figures 4, 5, 6, 7, 8, and 9 show the possible several flow patterns which can be obtained from four dyeing machines, with the relevant positioning of flow control valves.

Referring to Figures 1, 2 and 3, (1), (2), (3) and (4) are the four machines which constitute the set of dyeing machines in question, suitable for operating in parallel.

Each of them is equipped with a pump (P1), (P2), (P3) and (P4) which causes the dyeing bath of the respective machines to circulate, i.e., collects the dyeing bath from the tank bottom and delivers it, after flowing through the exchanger unit (S), to the Overflow funnel or Jet nozzle of each dyeing machine, in known way.

According to the present invention, the dyeing machine (1) is connected with the dyeing machine (2) by means of a pipe (5) installed at the level of the tank bottom portions of said dyeing machines, on which pipe (5), the pump (M1) and the valve (V1) are installed; and by a second pipe (6) positioned slightly under the maximal level which will be reached by the dyeing bath inside the tanks, and on which the valve (V4) is installed.

In its turn, the dyeing machine (2) is connected with the dyeing machine (3) by means of a pipe (7) installed at the level of their tank bottom portions, on which pipe (7) the pump (M2) and the valve (V2) are installed; and by a second pipe (8) positioned slightly under the maximal level which will be reached by the dyeing bath inside the tanks, and on which the valve (V5) is installed.

The dyeing machine (3) is connected with the dyeing machine (4) by means of a pipe (9) installed at the level of the tank bottom portions of said dyeing ma-

chines, on which pipe (9), the pump (M3) and the valve (V3) are installed; and by a second pipe (10) positioned slightly under the maximal level which will be reached by the dyeing bath inside the tanks, and on which the valve (V6) is installed.

When the dyeing machines are operating, the pumps (P1), (P2), (P3) and (P4) are kept operating as it normally occurs in Overflow or Jet dyeing machines operating on an individual basis, whereas the corresponding pumps (M1), (M2) and (M3), performing the task of homogenizing the dyeing bath by alternatively transferring it in both directions from each dyeing machine to the adjacent machine arranged in parallel to it, are caused to operate, or not according to the preselected parallel configuration as a function of the amount of fabric to be dyed into a determined colour.

It therefore happens that during a certain time period, by means of a pump (M) the dyeing bath is sucked from the bottom portion of a dyeing machine and is delivered to the immediately downstream dyeing machine, with the increase in dyeing bath level in said immediately downstream dyeing machine causing, by overflow through the higher positioned pipe, a stream of dyeing bath to flow from the top portion of the dyeing bath contained in said immediately downstream dyeing machine, towards the immediately upstream dyeing machine; during a same time period such operating way is reversed, and, during a subsequent time period of a same length, it is the dyeing bath contained in said downstream dyeing machine which is sucked from the bottom portion of the dyeing bath and is delivered to the immediately upstream dyeing machine, with the consequent increase in dyeing bath level inside said upstream dyeing machine, causing, by overflow through the higher positioned pipe, a dyeing bath stream to flow from the top portion of the dyeing bath contained in the upstream machine to the immediately downstream machine, and so on.

The present Applicant could find that according to this system, the dyeing bath contained inside a dyeing machine is caused to flow cyclically to another dyeing machine, and from each dyeing machine to all other dyeing machine, and a perfect homogenizing of the dyeing bath is thus obtained even in the case of a configuration with all machines being connected in parallel, with the dyeing bath being thoroughly mixed and with a surely homogeneous fabric dyeing being obtained.

Referring to Figures 4, 5, 6, 7, 8, and 9, the operating way is disclosed of a set of four machines in the various possible operating configurations.

Figure 4 discloses the case when all machines operate on an individual basis. In this case, pumps (M1), (M2) and (M3) do not operate and valves (V1)-(V4), (V2)-(V5) and (V3)-(V6) are closed.

Figure 5 shows the case when dyeing machines (1) and (2) operate in parallel and machines (3) and (4) operate individually. In this case, valves (V1)-(V4) are open, all other valves are closed and pump (M1) is run-

ning.

Figure 6 discloses the case when machine (1) and (2) operate individually and machines (3) and (4) operate in parallel. Consequently, in this case pumps (M1) and (M2) will be stationary, valves (V1)-(V2) and (V4)-(V5) will be closed, and valves (V3)-(V6) will be open and pump (M3) will be running.

Figure 7 shows the dyeing machines as being in a configuration of 2x2 in parallel. In this case, valves (V1)-(V4) will be open, pump (M1) will be running, valves (V2)-(V5) will be closed, pump (M2) does not operate, valves (V3)-(V6) will be open and pump (M3) will be running.

Figure 8 shows the machines (1), (2) and (3) as operating in parallel, with machine (4) operating individually. In this case, valves (V1)-(V4) and (V2)-(V5) are open, pumps (M1) and (M2) are running, valves (V3)-(V6) are closed and pump (M3) is stationary.

Figure 9 shows all four machines as operating in parallel.

In this case, all valves (V) are open and all pumps (M) are running.

Thanks to this system, besides reducing the number of valves and servocontrol units from 26 to 6 and limit switches from 52 to 12, the internal diameters of the pipes can be reduced because, while the dyeing bath from the upstream dyeing machine is flowing towards the immediately downstream dyeing machine, the dyeing bath from said immediately downstream dyeing machine is being simultaneously delivered back to the upstream dyeing machine owing to the effect of dyeing bath level increase.

Consequently, also the internal diameters of valves, as well as the size of the relevant drive means can be reduced, with overall costs being consequently reduced as well.

Furthermore, the electronic control system is much simpler, because it must control only 6 valves and 12 limit switches with a simple logics which must check only three well-defined combinations which are always the same.

The above exemplifying embodiment is supplied for merely explanatory, non-limitative purposes, and the technical solutions in order to implement the invention can be several; for example, the number of dyeing machines in the dyeing machine series can be higher or lower than in the example set forth hereinabove.

Claims

1. Machines (1,2,3,4) for textile dyeing of Overflow or Jet type installed in series, useable, according to requirements, according to different operating configurations, i.e., all operating in cascade (with this connection configuration being called, according to normal tinctorial language in parallel), or all machines individually, or connected in cascade (in parallel)

according to groups, or with a part of the machines being connected in cascade (in parallel) and part of them operating individually, characterized in that the loop for mixing the bath of the several machines is separated from the loop used for circulating the dyeing bath inside each machine; a pump of reversible type (M1,M2,M3) is used for circulating the bath from a dyeing machine to another dyeing machine, whereby the tank of each dyeing machine is connected to the tank of the immediately downstream dyeing machine by means of two pipes, wherein the one pipe (5,7,9) is installed in a low position at tank bottom level, on which a pump of reversible type (M1,M2,M3) and a valve (V1,V2,V3) are installed; and the other pipe (6,8,10) being installed at a higher level, slightly lower than the maximal level reached by the dyeing bath inside the tank, and on which a second valve (V4,V5,V6) is installed.

2. Machines according to claim 1, characterized in that for four machines (1,2,3,4) in series, six pipe lengths (5, 6, 7, 8, 9, 10) are provided which respectively connect mutually adjacent machines at the level of their respective tank bottom and at a higher level, slightly lower than the surface of the maximal level reached by the bath, on each pipe length the following devices being installed: on the bottom one, a pump of reversible type (M1, M2, M3) and a two-way valve (V1, V2, V3) and on the top pipe length a second two way valve (V4, V5, V6), with each valve being provided with pneumatic servocontrol unit and two limit switches.
3. Machines according to claim 1, characterized in that, in order to obtain a perfect bath mixing, the revolution direction of said pumps of reversible type (M1, M2, M3) is reversed at time intervals all of a same length, based on the preselected operating configuration.

Patentansprüche

1. Maschinen (1, 2, 3, 4) von Overflow- oder Jet Typ zum Färben von Geweben, die in Reihe aufgestellt und je nach den Anforderungen in verschiedenen Konfigurationen verwendbar sind, d.h. alle in Reihe angeschlossen (was im Jargon der Färbereien "paralleler" Anschluß genannt wird) oder alle im Einzelbetrieb oder gruppenweise in Reihe ("parallel") angeschlossen oder teilweise in Reihe ("parallel") angeschlossen und teilweise im Einzelbetrieb, die durch die Tatsache gekennzeichnet sind, da der Kreislauf zum Mischen der Färbedäer der verschiedenen Maschinen getrennt ist vom Kreislauf zur Zirkulation des Färbebad in jeder einzelnen Maschine; eine Umkehrpumpe (M1, M2, M3) wird

zur Zirkulation des Färbebad es von einer Färbemaschine zur anderen Färbemaschine verwendet, wobei die Wanne jeder Färbemaschine mit der Wanne der folgenden Maschine durch zwei Rohre verbunden ist, wovon ein Rohr (5, 7, 9), auf dem eine Umkehrpumpe (M1, M2, M3) und ein Ventil (V1, V2, V3) montiert ist, auf der Höhe des Wannenbodens angebracht ist; und das andere Rohr (6, 8, 10), auf dem ein zweites Ventil (V4, V5, V6) montiert ist, auf einem höheren Niveau etwas unterhalb des Höchststandes des Färbebad es in der Wanne angebracht ist.

2. Maschine gemäß Patentanspruch 1, die durch die Tatsache gekennzeichnet ist, daß für vier in Reihe angeschlossene Maschinen (1, 2, 3, 4) sechs Rohrabschnitte (5, 6, 7, 8, 9, 10) vorgesehen sind, die jeweils die nebenstehenden Maschinen auf der Höhe des Wannenbodens und wenig unterhalb des Höchststandes des Färbebad es miteinander verbinden, wobei auf jedem Rohrabschnitt jeweils montiert sind: auf dem unteren eine Umkehrpumpe (M1, M2, M3) und ein 2-Wegeventil (V1, V2, V3) und auf dem oberen ein zweites 2-Wege-Ventil (V4, V5, V6), wobei jedes Ventil mit einer pneumatischen Servosteuerung und zwei Endschaltern ausgestattet ist.

3. Maschinen nach Patentanspruch 1, die durch die Tatsache gekennzeichnet sind, daß der Drehsinn dieser Umkehrpumpen (M1, M2, M3) in gleichen Zeitabständen auf der Grundlage der gewählten Betriebskonfiguration umgekehrt wird, um eine perfekte Mischung des Färbebad es zu erreichen.

l'autre tube (6, 8, 10) étant installé à un niveau supérieur un peu au-dessous du niveau maximum du bain dans la cuve et sur lequel est montée une seconde valve (V4, V5, V6).

2. Machines selon la revendication 1 caractérisées par le fait que pour quatre machines (1, 2, 3, 4) en batterie sont prévus six tronçons de tube (5,6,7,8,9,10) qui unissent respectivement les manchons adjacents entre eux en correspondance avec le fond de la cuve et un peu au-dessous de la surface du niveau maximum atteint par le bain; sur chaque tronçon de tube sont montés les éléments suivants: sur le tronçon inférieur une pompe de type réversible (M1, M2, M3) et une valve à deux voies (V1, V2, V3) et sur le tronçon supérieur une seconde valve à deux voies (V4, V5, V6), chaque valve étant équipée de commande pneumatique assistée et de deux systèmes de fin de course.

3. Machines selon la revendication 1 caractérisées par le fait que, pour obtenir un mélange parfait du bain, le sens de rotation des dites pompes de type réversible (M1, M2, M3) est inversé à des intervalles de temps équivalents sur la base de la configuration opérationnelle choisie;

Revendications

1. Machines (1, 2, 3, 4) pour teindre des tissus de type Overflow ou Jet montées en batterie, utilisables sur la base des nécessités selon différentes configurations, et c'est-à-dire fonctionnantes toutes en série (branchement dit "en parallèle" dans le jargon des teintureries) ou toutes séparément ou par groupe reliées en série ("en parallèle") ou en partie reliées en série ("en parallèle") et en partie séparément, caractérisées par le fait que le circuit de mélange des bains des différentes machines est séparé du circuit utilisé pour la circulation du bain dans chaque machine; une pompe de type réversible (M1, M2, M3) est utilisée pour la recirculation du bain par une machine pour teindre à l'autre machine pour teindre où la cuve de chaque machine pour teindre est reliée à la cuve de la machine successive avec deux tubes, où un tube (5, 7, 9) est installé est installé en bas, en correspondance avec le fond de la cuve, sur lequel sont montées une pompe de type réversible (M1, M2, M3) et une valve (V1, V2, V3); et

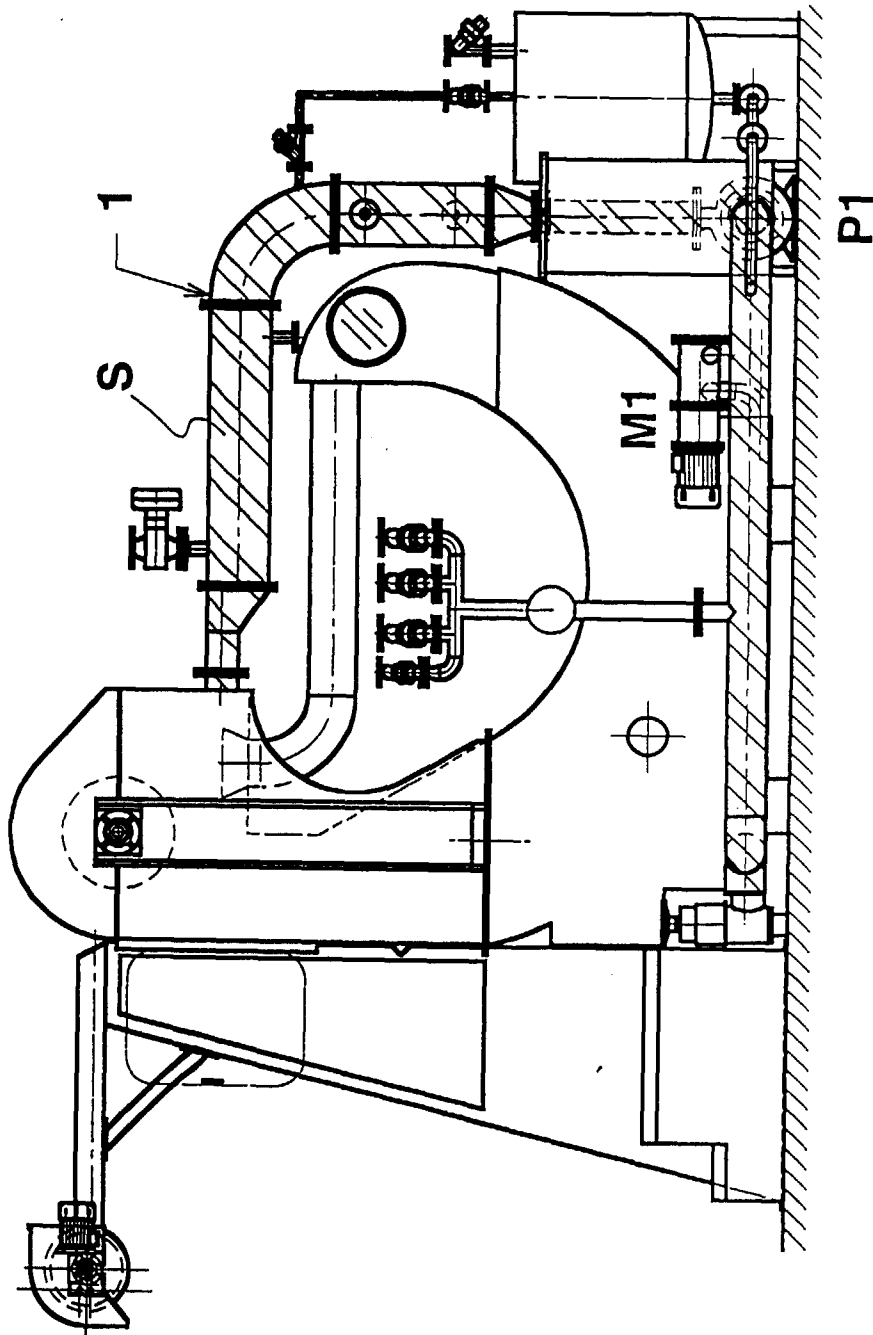

Fig.1

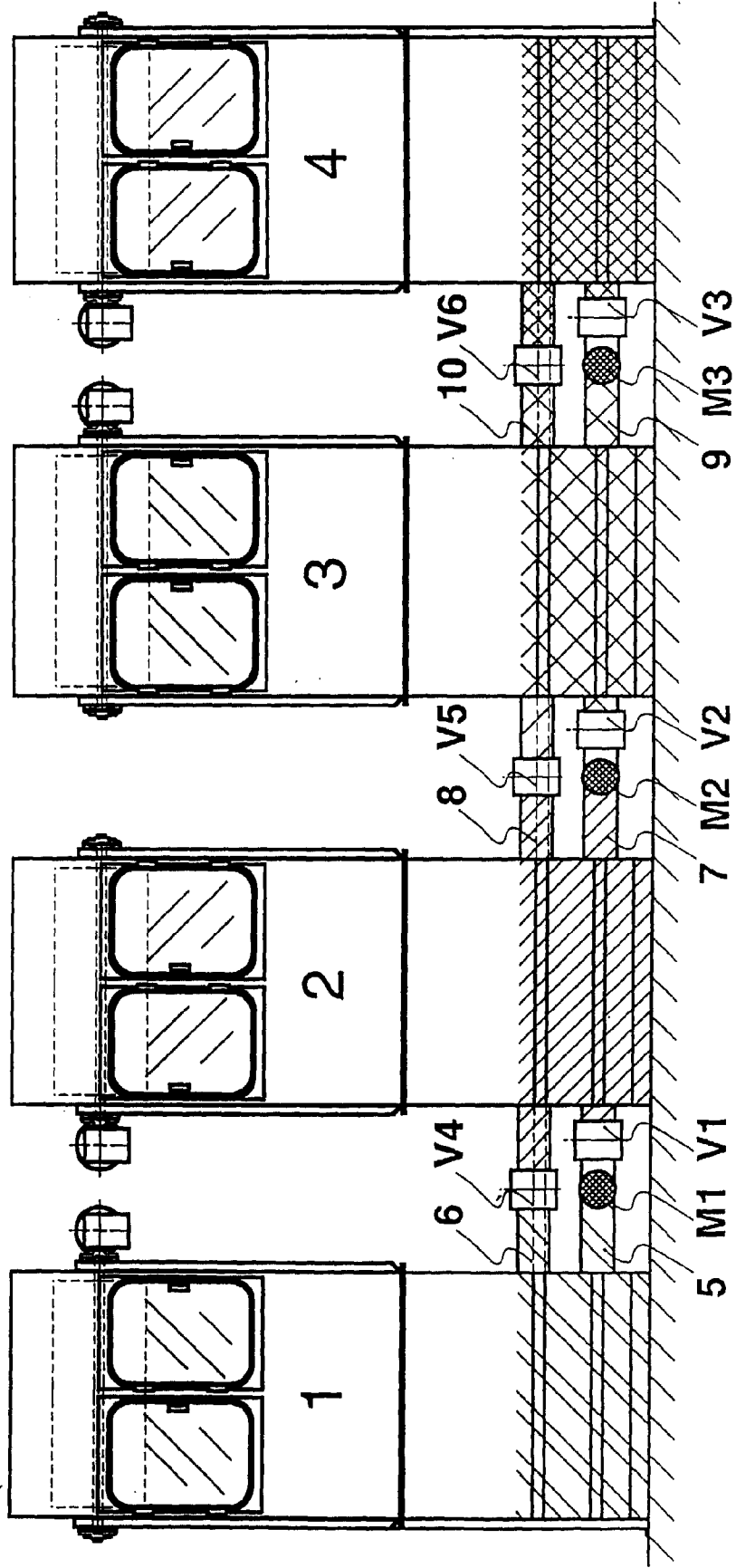

Fig.2

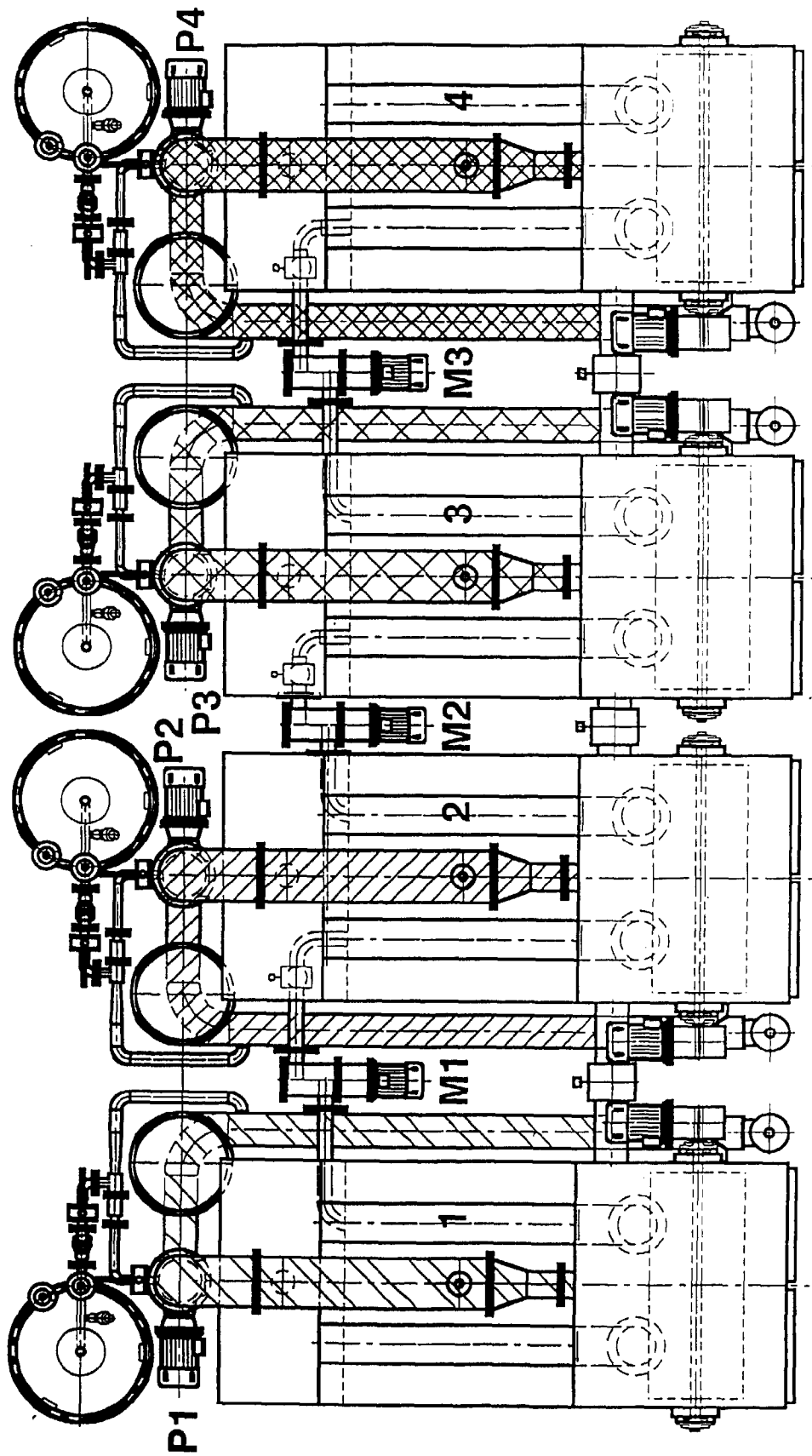

Fig.3

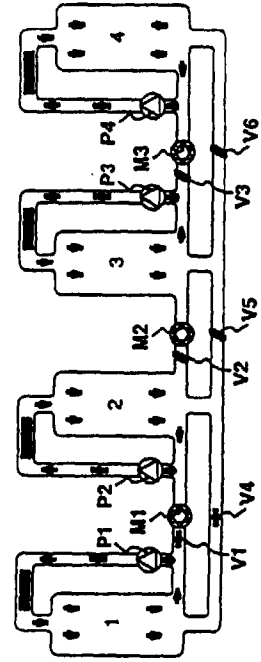

Fig.5

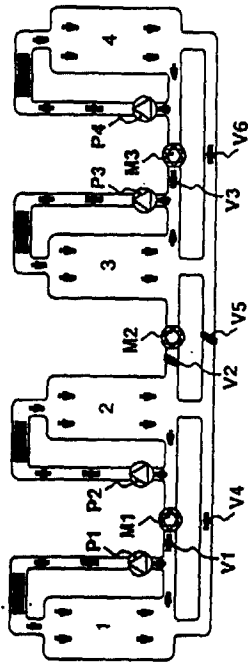

Fig.7

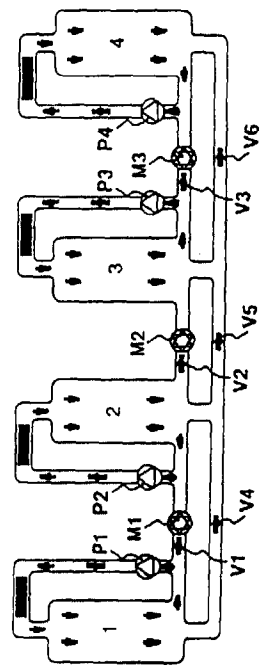

Fig.9

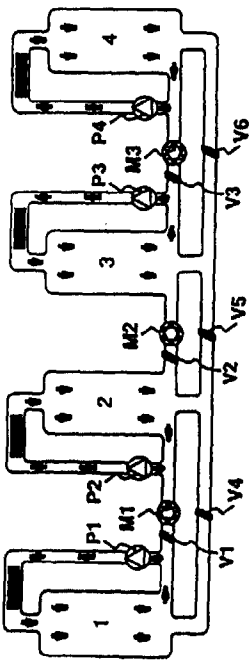

Fig.4

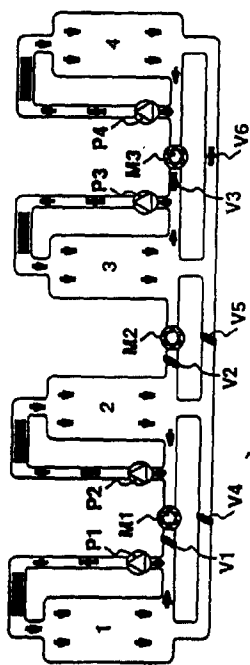

Fig.6

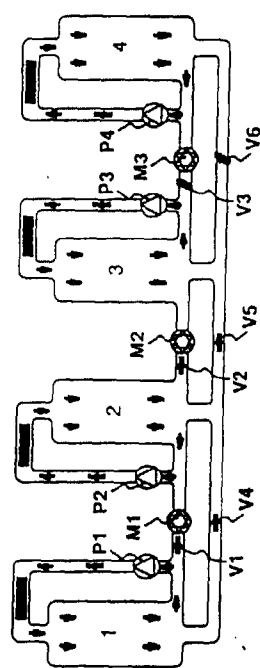

Fig.8