



(12) **EUROPEAN PATENT APPLICATION**

(43) Date of publication:  
19.11.1997 Bulletin 1997/47

(51) Int Cl. 6: **E05C 17/22, B60J 5/00**

(21) Application number: **97303260.0**

(22) Date of filing: **13.05.1997**

(84) Designated Contracting States:  
**DE ES FR IT SE**

(72) Inventor: **Taylor, Colin Jeffrey**  
**Walsall, West Midlands WS3 5BT (GB)**

(30) Priority: **14.05.1996 GB 9410046**

(74) Representative: **Spall, Christopher John**  
**BARKER, BRETTELL & DUNCAN**  
**138 Hagley Road**  
**Edgbaston Birmingham B16 9PW (GB)**

(71) Applicant: **Bloxwich Engineering Limited**  
**Bloxwich Walsall West Midlands, WS3 2JR (GB)**

(54) **Door checks for vehicles**

(57) A door check for vehicles in which a link (20) in the form of a strap is adapted to be pivotally connected at one end (21) to a door frame and is adapted to be withdrawn through a housing (1), mounted on a complementary part of the door against a restraining force applied to the strap by the frictional co-operation with the

strap of a restraining mechanism housed within the housing, and providing a mounting for a pair of rollers (9,7) which are resiliently urged into engagement with opposite faces of the link (20) and which provide a restraining force to the link (20). The link (20) is so profiled that the resistance to movement of the link (20) through the rollers (9,7) varies during the length of its travel.

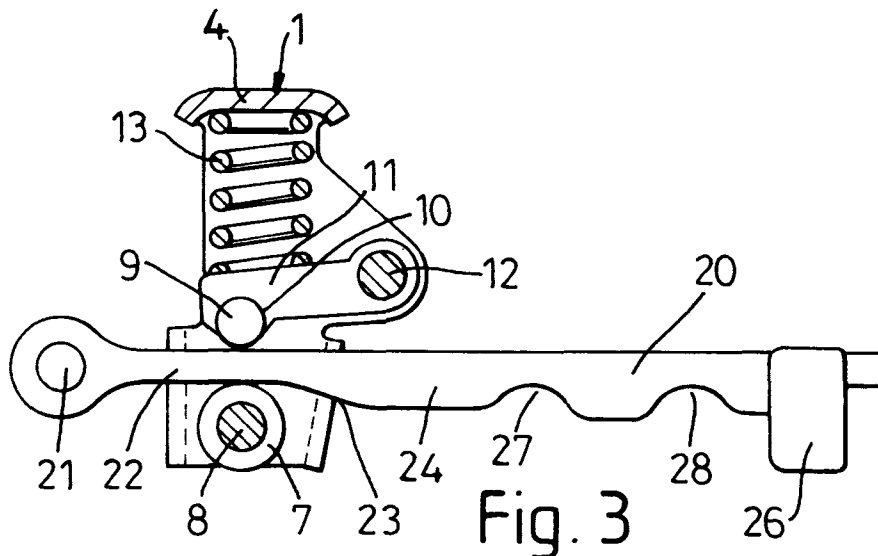

## Description

This invention relates to door checks for vehicles of the kind in which a link in the form of a strap adapted to be pivotally connected at one end to a door frame is withdrawn through a housing mounted on a complementary part of the door against a restraining force applied to the strap by the frictional co-operation with the strap of a restraining mechanism housed within the housing.

Most known door checks of the kind set forth include metal housings which are relatively heavy and relatively expensive to produce.

According to our invention, in a door check of the kind set forth for vehicles, the strap comprises a profile blank, and the housing provides a mounting for a pair of rollers which are resiliently urged into engagement with opposite faces of the link, the link being so profiled that the resistance to movement of the link through the rollers varies during the length of its travel.

Preferably the resistance to movement of the link through the rollers is smallest at a position of minimum travel, such as when the door is in a closed position, and increases as the door approaches an intermediate or a fully open position.

The fully opened position may be defined by the co-operation of an abutment on the link with at least one of the rollers to form a bump stop.

In one embodiment the housing comprises a pressed metal casing or bracket of substantially U-shaped formation between opposite limbs of which one of the rollers is journaled for rotation, and the other roller is carried by an arm in the form of a rocker which is angularly movable about a pivot between the limbs, a spring acting on the arm in a direction to urge the roller which it carries towards the other roller, whereby to apply a restraining force to the opposite surfaces of the link.

We therefore provide a light-weight door check which is simple in construction and cheap to produce.

One of the surfaces of the link may be planar and the other face may be of an irregular or undulating outline so that the resistance to movement of the link varies throughout the length of its travel. For example this surface may include an inclined face leading into axially spaced recesses adapted to receive one of the rollers whereby to define intermediate open positions for the door.

One embodiment of our invention is illustrated in the accompanying drawings in which:-

**Figure 1** is an inverted plan view of a door check for a vehicle door with the strap omitted for clarity;

**Figure 2** is an end view of the check; and

**Figure 3** is a section on the line 3-3 of Figure 2 and including the link.

The door check illustrated in the drawings comprises a housing 1 in the form of a light-weight pressed metal casing or bracket of generally U-shaped outline including spaced limbs 2, 3 which depend from an end plate 4. The limbs 2, 3 terminate at their distal ends in oppositely directed cranked portions comprising a pair of aligned lugs 5 which provide mountings for fixing studs 6 by means of which the casing can be secured to a vehicle door.

A roller 7 is journaled for rotation on a pin 8 fixedly secured at opposite ends in the limbs 2 and 3, and a second roller 9 is rotatably mounted in a recess 10 at the inner end of an arm 11 of which the outer end is mounted for angular movement about a pivot pin 12 also extending between the limbs 2 and 3. A compression spring 13 acts between the rocker 11 and the end plate 4 to urge the roller 9 towards the roller 7.

A strap 20 in the form of a profiled link extends through the casing between the rollers 9 and 7 with a restraining force applied to it by the load in the spring 13 which is transmitted through the rocker 11. The link 20 has a planar upper surface with which the movable roller 9 is in rolling engagement, and a lower surface of irregular or undulating configuration. As illustrated the link 20 at one end is provided with an opening 21 to form a pivotal connection with a door frame and which is disposed at all times on one side of the casing. A portion 22 of constant thickness leads from the opening 21 to an outwardly inclined face 23, and the face 23 in turn, leads into a second, parallel sided portion 24 of greater thickness than the portion 22. The portion 24 terminates at an enlarged abutment 26 at the opposite free end of the link. A pair of axially spaced semi-circular recesses 27, 28 are formed in the portion 24, spaced axially between the inclined face 23 and the abutment 26.

When the door check is installed in a vehicle and the door is in the closed position, the relative positions of the link 20 and the casing 1 are similar to that shown in Figure 3 with a minimum restraining force applied to the link 20 since the rocker 11 is at an extreme position. As the door is opened and the link 20 is withdrawn through the rollers 7 and 9, the resistance to movement of the link 20 increases as the roller 7 engages with the inclined face 23 and which provides a gradual lead into the portion 24. At this point the resistance to movement is increased due to compression of the spring 13 caused by angular movement of the rocker 11, in order to accommodate the increased effective width of the link at that point. Further movement in the same direction causes the roller 7 to be received in the recess 24 to define a first intermediate open position. If this position is insufficient for the needs of the occupant of the vehicle then the door may be opened further with the roller 7 being received in the recess 28 to define a second intermediate open position. Further movement of the door in the same direction to disengage the roller 7 from the recess 28 causes the abutment 26 to engage with the roller 7 and define a bump stop limiting further travel of

the link 20 and limiting further movement of the door in a opening direction.

In the construction described above the resistance to movement of the link 20 through the rollers 7, 9 is smallest at a position of minimum travel, when the door is substantially in a closed position, and increases as the door approaches an intermediate or fully open position. 5

In a modification the fixing stud 6 may be omitted, the casing 1 may be fixed to the door by the use separate screws screwed into tapped holes in the flanges 5. 10

### Claims 15

1. A door check for vehicles in which a link in the form of a strap is adapted to be pivotally connected at one end (21) to a door frame and is adapted to be withdrawn through a housing (1), mounted on a complementary part of the door against a restraining force applied to the strap by the frictional co-operation with the strap of a restraining mechanism housed within the housing, and providing a mounting for a pair of rollers (9,7) which are resiliently urged into engagement with opposite faces of the link (20) and which provide a restraining force to the link (20), characterised in that the link (20) is so profiled that the resistance to movement of the link (20) through the rollers (9,7) varies during the length of its travel. 20 25 30
2. A door check as claimed in claim 1, in which the resistance to movement of the link (20) through the rollers (9,7) is smallest at a position of minimum travel, such as when the door is in a closed position, and the resistance to movement increases as the door approaches an intermediate or a fully open position. 35
3. A door check as claimed in claim 2, in which the fully opened position is defined by the co-operation of an abutment (26) on the link (20) with at least one of the rollers (9,7) to form a bump stop. 40
4. A door check as claimed in any preceding claim, in which the housing (1) comprises a pressed metal casing or bracket of substantially U-shaped formation between opposite limbs (2,3) of which one of the rollers (7) is journalled for rotation, and the other roller (9) is carried by an arm (11) in the form a rocker which is angularly movable about a pivot (12) between the limbs (2,3). 45 50
5. A door check as claimed in claim 4, in which a spring (13) acting on the arm (11) in a direction to urge the roller (9) which it carries towards the other roller (7) applies a restraining force to opposite surfaces of the link (20). 55

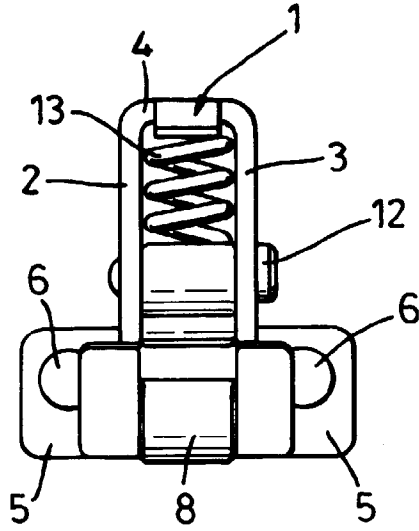

Fig. 1

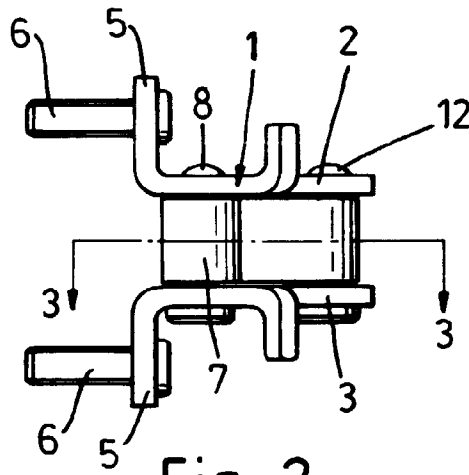

Fig. 2

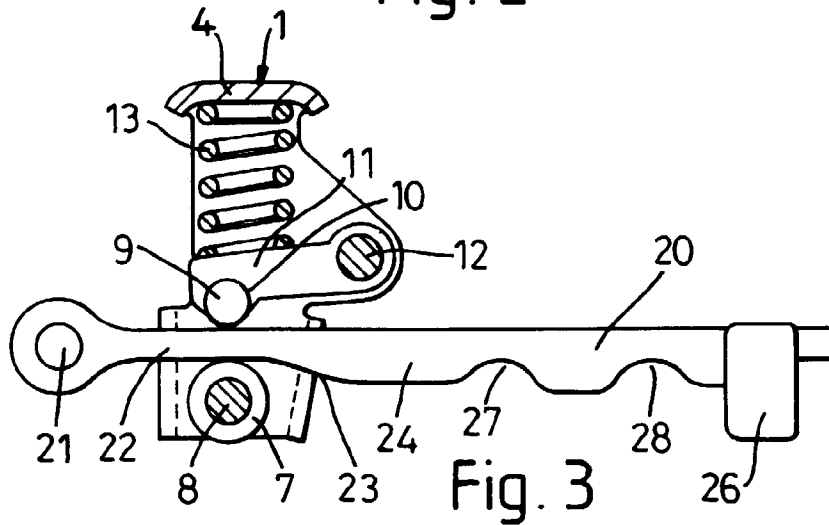

Fig. 3