



Europäisches Patentamt
European Patent Office
Office européen des brevets



(11) **EP 0 808 723 B1**

(12) **EUROPEAN PATENT SPECIFICATION**

(45) Date of publication and mention
of the grant of the patent:
19.01.2000 Bulletin 2000/03

(51) Int Cl.7: **B41N 3/00, B24B 5/04**

(21) Application number: **97108377.9**

(22) Date of filing: **23.05.1997**

(54) **Method to remove chromium plating and engraving from gravure rollers and machine suited to carry out such a method**

Verfahren und Maschine zum Entfernen von Gravuren und Chromschichten von Tiefdruckzylindern
Procédé pour enlever la couche de chrome et les gravures d'un cylindre de gravure et machine pour l'application de ce procédé

(84) Designated Contracting States:
AT BE CH DE DK ES FR GB IT LI NL SE

(72) Inventor: **Rosa, Valerio**
36030 Zugliano (VI) (IT)

(30) Priority: **23.05.1996 IT VI960084**
28.02.1997 IT VI970036

(74) Representative: **Forattini, Amelia et al**
c/o Internazionale Brevetti
Ingg. ZINI, MARANESI & C. S.r.l.
Piazza Castello 1
20121 Milano (IT)

(43) Date of publication of application:
26.11.1997 Bulletin 1997/48

(73) Proprietor: **Rosa, Valerio**
36030 Zugliano (VI) (IT)

(56) References cited:
BE-A- 728 907 **CH-A- 156 773**
CH-A- 160 773 **DE-C- 530 991**

EP 0 808 723 B1

Note: Within nine months from the publication of the mention of the grant of the European patent, any person may give notice to the European Patent Office of opposition to the European patent granted. Notice of opposition shall be filed in a written reasoned statement. It shall not be deemed to have been filed until the opposition fee has been paid. (Art. 99(1) European Patent Convention).

Description

[0001] The invention concerns a method for removing the chromium plating and the engraving from gravure rollers and a machine suited to applying such a method.

[0002] It is known that gravure rollers consist of a steel cylinder covered with a copper coat galvanically obtained, on which a drawing can be impressed to be reproduced on the paper. On the copper coat a chromium protective covering, which is itself galvanically obtained, is then settled.

[0003] After a certain number of working hours, the cylinder diameter has to be reduced to eliminate the engraving imprinted on the copper coat and such an operation, which is quite difficult as it is well known to those skilled in the art, consists of a first step in which the chromium is submitted to a galvanic treatment for chromium plating removal and a second step in which special machines work the copper coat removing the engraving imprinted on it, as known e.g. from CH-A-156773.

[0004] Such a method presents the disadvantage of requiring the use of very expensive machines and being divided into two steps, performs quite long working cycles because of the set up time necessary to move the cylinders from the galvanic chromium plating removal plant to the machine tools.

[0005] Otherwise instead of the removing of the protective chromium covering by a galvanic treatment of chromium plating removal, treatments are known which use lathe - smoothing machines which turn the cylinder and at the same time remove the chromium coat and the down below engraving on the copper.

[0006] Then the copper coat is smoothed.

[0007] Such a working method, however rarely used, requires cheaper equipment than the previously described but it requires longer working times.

[0008] The present invention proposes to overcome such disadvantages.

[0009] In particular, the object of the present invention is to realize a method and a machine suited to put into effect such a method, which allows the working of gravure rollers, obtaining:

- the removing of the chromium plating and of the down below engraving on the copper with only one operation;
- the smoothing and the polishing of the copper coat down below said chromium surface;
- the realization of a perfectly cylindrical surface;
- the breaking and the removing of the chromium surface from the cylinders without causing stress and damage to the down below copper coat;
- said operations are performed with working times and with costs lower than the ones realized by the known methods.

[0010] Said objects are achieved providing a method for removing the chromium plating and the engraving

from gravure rollers formed by a metallic shell galvanically covered with a copper coat on which said engraving is realized and a protective chromium covering is galvanically settled, said method, according to the main claim is characterized in that it includes the following operations:

- making said cylinder turn around its longitudinal axis;
- removing said chromium covering by contrasting bodies belonging to at least one first rotating disk;
- smoothing said copper coat, down below said chromium covering, by at least a second rotating disk provided with abrasive elements, said removing of said chromium covering being determined by the breaking of the covering itself which is obtained through the elastic collapsing of the down below copper coat when said contrasting bodies interfere against said chromium coat.

[0011] Advantageously and according to a preferred embodiment, said contrast bodies are diamond granules inserted on a disk surface fixed to a working operative head which makes it turn.

[0012] Each diamond granule, during the disk rotation to which it is fixed, forces the chromium covering against the down below copper coat that, being stronger, collapses elastically causing the chromium breaking that is more rigid. The chromium is, in this way, shattered into many pieces and can be easily torn up from the down below copper coat to which is galvanically secured.

[0013] Preferably in order to remove such chromium coat, two disks are used and one mainly performs the chromium breaking whereas the second one performs even the engraving removal.

[0014] After the chromium and engraving removing, the down below copper coat is smoothed by the second rotating disk provided with abrasive elements belonging to the known technique.

[0015] Advantageously, the method of the invention is applied using a modular smoothing - polishing machine comprising a basement which includes a support and a rotating group of a cylindrical body to be smoothed and a lateral surface working group of said cylindrical body, said working group comprising:

- a plurality of operating heads, each of them supplied with at least a rotating disk provided with abrasive elements and suited to realize the working of the lateral surface of said cylindrical body;
- a frame supporting said operating heads and which is supported by on supporting elements fixed to said basement to which it is connected by sliding means cooperating with handling means suited to obtain the shifting of said smoothing group against said cylindrical body to be smoothed, and it is characterized in that said operating heads are connected to kinematic elements supported by said frame and

getting them moving according to a longitudinal direction substantially parallel to the generatrices of the lateral surface of said cylindrical body to be worked, each of said operating heads being provided with an oscillating group suited to realize the shifting of the rotating disk belonging to each of them, in a substantially vertical direction, contemporary to the moving of each of said heads according to said longitudinal direction.

[0016] According to a preferred embodiment, the supporting and rotating group of the cylindrical body to be worked, includes a couple of opposed tailstocks that support the cylinder to be worked and a motorization group fixed to one extremity of said cylinder suited to put it under rotation around the horizontal axis. Said tailstocks and said motorization group are supported by the basement of the machine.

[0017] Said sliding means, which allow the shifting of said operating heads, are formed by slides which cooperate with said handling means consisting of ropes connected to said sliding means and wound on drums and transmission pulleys.

[0018] The operative heads are connected to the frame by kinematic elements consisting of closed jack chains which engage with sprocket wheels supported by a central structure which insists on the same frame. At least one of said sprocket wheels, which engage with each chain, is connected with an engine which makes it turn on clockwise or anticlockwise direction according to the operative needs.

[0019] The oscillation group, with which each operative heads is equipped, is a mechanic-pneumatic group operating by an engine, the rotation of which is controlled by an electronic system with amperometric control, suited to change the position of the rotating disk which present an abrasive surface against the working surface and suited to maintain the pressure constant during the machining.

[0020] Said aims and said advantages will be better stressed during the description of a preferred embodiment of the method and of the machine object of the invention, with reference to the enclosed drawings wherein:

- Fig. 1 shows a gravure roller applied to the machine, object of the invention, by which the method, also object of the invention, is applied;
- Fig. 2 shows the breaking and removing step of the chromium covering;
- Fig. 3 shows the surface of the gravure roller after the chromium removing and before undergoing the smoothing step;
- Fig. 4 is a front view of the machine object of the invention;
- Fig. 5 is a side view of the machine of Fig. 4;
- Fig. 6 shows a front view of the details of the smoothing groups with which the machine object of

the invention is equipped;

- Fig. 7 is an axonometric view of the detail of one vertical rod which connects the frame to the basement of the machine object of the invention;
- 5 - Fig. 8 is a front view of the vertical rod of Fig. 7;
- Fig. 9 shows the vertical moving system of the frame which supports the operating heads, the last ones not drawn for an easy representation;
- 10 - Fig. 10 shows the detail of sliding means of the frame against the vertical rod represented in Fig. 7;
- Fig. 11 shows the horizontal moving system of the frame which supports the operating heads, the last ones not drawn;
- 15 - Figs 12, 13, 14 and 15 show different steps of the work of the machine according to the invention;
- Fig. 16 is a front view of an operating unit of the machine object of the invention;
- Figs. 17 and 18 show the operating unit of Fig. 16 during two different steps of the work;
- 20 - Fig. 19 is a partial sectioned view of the top side view of the operating unit represented in Fig. 18.

[0021] As it can be observed in Fig. 1, the method of the invention is applied using an operating head 1 of an operating machine, object of the invention too and visible in Fig. 2, where this is indicated as a whole with 200, by which it can be carried out the machining of the surface of the gravure roller 2 which is made turn around its longitudinal axis 3 by rotating means.

25 **[0022]** A first disk 4 is applied to the operating head 1, this disk being formed, as it can be observed, by a small plateau which is made turn around the longitudinal axis 10 of said operating head. Said small plateau 4, as it can be observed in the detail of Fig. 2, is provided with a plurality of contrasting bodies 41 which are formed by a plurality of diamond granules applied to said disk 4.

30 **[0023]** Alternatively, said contrasting bodies 41 can be even made of a plurality of synthetic or artificial granules for instance boron carbide or similar material which present a lower hardness than the diamond but close to it.

35 **[0024]** The cylinder 2, as it can be observed in the detail of Fig. 2, is formed by a shell 21, preferably made of steel, on which a copper coat 22 that supports the engraving is galvanically settled and it is covered by a protective chromium coat 23.

40 **[0025]** During the rotation of the cylinder 2 and the disk 4, each of them around their own longitudinal axis 3 and 10 respectively, each contrasting body 41 forces the protective chromium covering 23 and breaks it because of the elastic collapsing of the down below copper coat 22. It is just the collapsing of said copper coat 22 and the hardness of the chromium covering which allow the diamond granules 41 to break the chromium, crumbling it in very little pieces 230 without abrading it, but detaching it from the copper and moving it away.

45 **[0026]** During such steps of crumbling and moving away the chromium, the engraving present in the copper

coat is eliminate too. In some cases the use of another rotating disk may be necessary to obtain the complete removal of the engraving and of the possible chromium residuals.

[0027] After the chromium and copper engraving removal, the copper surface itself, indicated with 222 in Fig. 3, appears lightly wrinkled and is smoothed by the use of other rotating disks belonging to respective operating heads.

[0028] The operating machine which realizes the above described method of the invention and object of the invention too, is represented in Figs. 4 and 5 where it is indicated as a whole with 200 and comprises a basement 202 which includes a support and a rotating group 3 of a cylindrical body to be worked 2 and a smoothing group, indicated as a whole with 5, of the surface 41 of said cylindrical body 2.

[0029] Said supporting and rotating group 3 consists of a couple of tailstocks 40 which support the extremities of said cylinder to be smoothed 2 which is made turn by a motorization group 42. The surface 441 of said cylinder body 2 is maintained wet by a wetting parallel cylinder which gets the refrigerating liquid from a basin 32 which insists on the basement 202.

[0030] The lateral surface 441 of said cylindrical body 2 is smoothed by said smoothing group indicated as a whole with 5 which, as it can be observed even in Fig. 3, is formed by a plurality of operating heads 1.

[0031] Said operating heads 1 are connected to kinematic elements more visible on the detail of Fig. 3, said elements belonging to a central structure 50 supported by a frame 51 which is supported by supporting elements formed by a couple of vertical rods 35 located at its extremities and fixed to said basement 202.

[0032] Said kinematic elements visible in Fig. 3 comprise sprocket wheels 52 spaced out among them and located on two, substantially horizontal and parallel planes where a chain 53 is placed in connection of each plane on which such sprocket wheels 52 lie. Such a chain 53 is connected as a ring between at least two of said sprocket wheels 52 with which it is engaged and at least one of those is connected with rotation means suited to make it turn to obtain the movement of said chain with which it is engaged.

[0033] Said operating heads 1 are fixed to said chains 53 each one by a support 81 and are provided with wheels 91 sliding on tracks 92 realized in the central structure 50 and which have the function of supporting each operating head and of driving it when the chains 53 are put into action.

[0034] It can be observed in Figs. 16, 17 and 18 that each support 81 is provided with driving means 83 which include an engine 82 and permit the vertical shifting along the axis 84 of the support 81 when said engine 82 is put into vertical alternate movement by an oscillation group indicated as a whole with 8 and supported by the same support 81.

[0035] In order to move said smoothing group 5

against said cylinder 2, the frame 51 is vertically and horizontally moved by sliding means which connect it to each vertical rod 35 and which comprise, as it can be observed in Figs. from 7 to 10:

- vertical sliding means, indicated as a whole with 70 and visible in Figs. 7, 8 and 9, which are formed by a plate 71, vertically sliding along the columns 72 fixed to said vertical rod 35 and insisting on said basement 202, which allows the raising and the lowering of said frame 51;
- sliding means moving in transversal direction against the longitudinal axis 45 of the cylinder 2, indicated as a whole with 73 and visible in Figs. 8, 9 and 10, which are formed by a slide 74 fixed to said plate 71 which allows the horizontal moving of the extremity 77 of the frame 51 against said plate 71.

[0036] In order to carry out vertical and transversal shifting of said frame 51, moving means are used which comprise:

- vertical handling means, indicated as a whole with 75 in Fig. 9, which comprise a couple of ropes 175, supported by pulleys 375, each rope presenting an end connected to one of said plates 71 and the opposite end rolled up on a rolling up drum 275 which is made turn by an engine.
- handling means in transversal direction against the axis of the cylinder 2, indicated as a whole with 76 and visible in Fig. 11, which comprise a couple of ropes 176 supported by pulleys 376, each rope presenting an end connected to one extremity 77 of said frame 51 and the opposite end connected to a rolling up drum 276 which is made turn by an engine 376.

[0037] Regarding said engine 376 it can be observed in Fig. 10 that it is fixed to said plate 71 by a bracket 171 and so it is fixed to the frame 51. Moreover, said bracket 171 supports a shaft 174 passing inside a tubular element 274 with the interposition of a spring 374 coaxial to said shaft 174, wherever said shaft 174 and said tubular element 274 are transversally placed to the frame 51. A plate 474 fixed to the frame is located on the opposite side of the engine 376 and contrasts against the spring 374. When the pull of the rope 176 moves the frame 51 in the direction of 251, the plate 474 presses the spring 374 and its elastic recovery allows the coming back of the frame 51 according to the moving direction 151 opposite to the direction 251, when the rope 176 is released.

[0038] In order to begin the working is necessary to place the cylindrical body 2 to be smoothed between the tailstocks 40 in a way that the surface to be smoothed 441 is horizontal and parallel to the abrasive surface of each rotating disk 4. The operating heads 1 are then brought near to the surface 441 to be smoothed, moving

the frame 51 by sliding means and by handling means and feeding with compressed air the pneumatic cylinder 100 with which the oscillation group 8 belonging to each operating unit is equipped.

[0039] The rotating disks 4 are then aligned on a level 162 tangent to the surface 441 to be smoothed, as it can be observed in Fig. 12, and then in contact with the surface to be worked as it can be observed in Figs. 13 and 14.

[0040] The engine 82 of each operating head 6 is switched on, so that the rotating disk 4 of each head starts the working while at the same time motorizing means, not represented, put in rotation the sprocket wheel 52 which by the chain movement 53 move all the operating heads 1 according the longitudinal direction, parallel to the axis 45 of the cylinder 2.

[0041] This cylinder is made turn around its own axis 45 by the motorization group 42 and it is worked on its whole length and on its whole lateral surface.

[0042] During the working, acting on the handling transversal means 76, the frame 51 and so the smoothing group 5 and the operating heads 1 are horizontally shifted in such a way that, as it can be observed in Figs. 14 and 15, additional points 163, 164 and successively all the points of the abrasive surface of the rotating disk 4 enter progressively in contact with the generatrix of the surface 441 of the cylinder 2 to be smoothed.

[0043] This allows a uniform use of the abrasive surface of the rotating disk and avoids the kneading phenomenon.

[0044] It is important to stress that all the rotating disks 4 must work the surface 441 of the cylinder 2 being placed in contact with it in correspondence of an intermediate point of their internal surface that, as it can be observed in Figs. 13, 14, and 15, corresponds respectively to the points 163, 164, and 165 as the heads are transversally moved against the cylinder, so to affect successively all the abrasive working area of the disk.

[0045] In order to optimise the working, the action of the first rotating disk 4 is all-important and eventually even the action of the second one, which enter in contact with the surface to be worked and, operating as it has been already described, realize the breaking of the chromium coat causing the keeping away not by abrasion similar to the one which happens in the machine tools of known technique but instead for breaking which cuts it into pieces 230 without abrading it.

[0046] The rotating disks which are subsequent to the first one, are provided with abrasive means which have an abrasive finishing action.

[0047] During the working, each rotating disk 4 is even vertically moved in an alternate way, up and down against the working surface 441 by the already said oscillation group, indicated as a whole with 8, with which each operating unit 1 is equipped.

[0048] The presence of such oscillation group has a fundamental function in the smoothing action of the cylinder and it allows to realize a cylindrical surface sub-

stantially free from depressions as it allows to maintain a constant pressure of the rotating disks 4 against the surface to be smoothed 441.

[0049] Each oscillation group 8, as it can be observed in Figs. 16, 17, 18 and 19, comprises the already said pneumatic cylinder 100 whose stem 109 is fixed to said engine 82 and whose body 108 is fixed by the bracket 111 to the structure 81 fixed to the chains 53 and which support the engine 82.

[0050] When the rotating disk 4 finds a point with stronger resistance, the engine 82 absorbs more current because of the greater hardness of the cylinder to be smoothed in that point that require higher abrasive power from the abrasive surface 41 of the disk 4. This higher absorption of current is noticed by an amperometric card belonging to a control group 300, visible in Fig. 4, whereas the relative absorption of the current is indicated on the display 301.

[0051] In particular, on the group 300 a plurality of digital displays are available, each one connected by an amperometric card to the engine 82 with which a specific operating unit 1 is equipped.

[0052] When the engine 82 requires more current, it is necessary to put up the rotating disk 4 and this is obtained by the oscillation group 8. In fact the pneumatic cylinder 100 presents the body 108 provided with a female thread 110 with which a screw 113 is coupled belonging to an engine 114 fixed by a square 112 to the same bracket 111.

[0053] The body 108 of the pneumatic cylinder 100 is integral with the engine 82 by a pneumatic auxiliary cylinder 115 which is provided with a first connecting element 116 which contrasts a second connecting element 117 fixed to a plate 118 which is fixed to the engine itself 82.

[0054] Said connecting means 116 and 117 are formed by a plurality of metallic points fixed to a support suited to realize mutual friction when they are coupled, in such a way to avoid relative sliding among the members of the own system.

[0055] When said auxiliary cylinder 115 puts in mutual adhesion said connecting means 116 and 117, the body 108 of the pneumatic cylinder 100 forms a single body with said engine 82 and so any possibility of relative moving between the two, due to the pneumatic action that is to say to the moving of the stem 109 is prevented.

[0056] On the contrary, a signal sent by the amperometric card as it detects an increase or a decrease of the current absorbed by the engine 82, puts in rotation according the anticlockwise or the clockwise direction the engine 114 which accordingly puts in rotation the screw 113 that as engages the female screw 110, causes the raising or the lowering of the body 108 of the pneumatic cylinder 100 and so even of the engine 82 and of the relative rotating disk 4. In such a way to each pressure variation found by the abrasive disk 4 during the working and which corresponds to a current absorbing variation, the system reacts with a signal sent by the

control amperometric card to the engine 114, acting it and putting up or down, according to the situations, the whole engine 82 and changing in this way the contact between each disk 4 and the surface 441 of the cylinder 2 under working.

[0057] During the horizontal moving and the contemporary rotation of the disks 4, also a vertical oscillatory movement is performed in function of the variations of the absorbed current caused by the different hardness that each abrasive disk finds during the working.

[0058] According to what has been described, it is understood that the method and the machine that realizes such method, both being object of the invention achieve all the prefixed objects.

[0059] Above all, it is reached the aim to release a method that allows the removing of the protective chromium covering by breaking and not by abrasive action.

[0060] Further, the chromium and the engraving removal, the polishing of the copper coat are provided with the same machine obtaining a global reduction of the cycle time. The working method of the invention results in this way faster and cheaper than the methods of the known technique.

[0061] The machine that realizes the method of the invention allows to obtain a surface quite cylindrical, quite polished and free from waving, because of the presence in each operating unit of the oscillation group that during the longitudinal moving of the rotating abrasive disks allows the raising and the lowering of the disks against the surface to be smoothed, by an amperometric control and as a function of the current variations due to the variations of the resistance that each abrasive disk finds during the working.

[0062] It is clear that to obtain the best results related to the hardness of the surface to be removed, abrasive disks with different grains and the most useful rotating speed of the same disks, will be used.

[0063] Further, the amperometric cards, which drive the current absorption in a differentiated way for each operating unit, allow to change the smoothing pressure for each one.

[0064] Advantageously, as the rotating disks of the operating heads work parallel to the generatrix of the cylinder to be worked, it is possible to eliminate all the helicoidal marks produced by previous turning or grinding operations.

[0065] It is necessary to point out that the number of the operating heads with which the machine is equipped could be whichever, and each of them forms a smoothing "module".

[0066] During the Manufacturing phase, the machine according to the invention could undergo variations which can consist for instance, of different embodiments of the sliding devices and of the moving means of the frame and the operating units supported by the frame or different embodiments of the oscillation group with which each operating unit is provided.

[0067] It is obvious that the machine of the invention

could be realized with consistent dimensions suited to work cylindrical bodies of whichever diameter and length.

[0068] It is to be understood that all the described variations and any other possible, without departing from the scope of the appended claims, are to be considered protected by the present invention.

10 Claims

1. A method for removing the chromium plating and the engraving from gravure rollers (2), consisting of a metallic shell (21) galvanically covered by a copper coat (22) on which said engraving is made and a protective chromium covering (23) is galvanically settled, **characterized in that** it comprises the following operations:

- making said cylinder (2) turn around its longitudinal axis (3);
- removing said chromium covering (23) by contrasting bodies (41) belonging to at least one first vertically shiftable rotating disk (4) while the rotating disk is maintained at a constant pressure against the surface of the gravure roller (2);
- smoothing said copper coat (22) down below said chromium covering (23), by at least a second rotating disk provided with abrasive elements, said removing of said chromium covering (23) being determined by the breaking of the chromium covering (23) which is obtained through the elastic collapsing of the down below copper coat (22) when said contrasting bodies (41) interfere against said chromium coat (23).

2. A method according to the claim 1) **characterized in that** said contrasting bodies are made of diamond granules (41) which are fixed in said rotating disk by a bonding agent (42).

3. A modular smoothing - polishing machine (200) for cylindrical surfaces (441) suited to realize the removing method of the chromium plating according to the claim 1) comprising a basement (202) which holds a support and a rotating group (3) of a cylindrical body (2) to be worked and a smoothing group (5) of the lateral surface (441) of said cylindrical body (2), said smoothing group (5) comprising:

- a plurality of operating heads (1), each of them provided with at least a rotating disk (4) having contrasting bodies (41) suited to realize the working of the lateral surface (441) of said cylindrical body (2);
- a frame (51) supporting said operating heads

- (1) and which is supported by supporting elements (35) fixed to said basement (202) is connected to said support elements (35) by sliding means (70, 73) cooperating with handling means (75, 76) suited to obtain the shifting of said smoothing group (5) against said cylindrical body (2) to be worked, **characterized in that** said operating heads (1) are connected to kinematic elements (52, 53) supported by said frame (51) for moving said operating heads (1) according to a longitudinal direction (45) substantially parallel to the generatrices of the lateral surface (441) of said cylindrical body (2) to be smoothed, each of said operating heads (1) being provided with an oscillation group (8) suited to realize the shifting of the rotating disk (4) belonging to each of them, in a substantially vertical direction, contemporary to the moving of each of said heads according to said longitudinal direction (45), for maintaining a constant pressure of the rotating disks (4) against the surface to be smoothed.
4. A modular smoothing - polishing machine (200) according to the claim 3) **characterized in that** each operating head (1) comprises an engine (82) smoothly connected by driving means (83) with a support (81) fixed to said kinematic elements (53) and it is provided with said oscillation group (8) which comprises a pneumatic cylinder (100) whose stem (109) is fixed to said engine (82) and whose body (108) is fixed by a bracket (111) to said structure (81), said body (108) being provided with a female thread (110) with which a screw (113) is coupled belonging to an engine (114) fixed by a square (112) to said bracket (111), locking means made suitable for a fixed connection between said body (108) of said pneumatic cylinder (100) and said engine (82).
5. A modular smoothing - polishing machine (200) according to the claim 4) **characterized in that** said locking means comprise a pneumatic auxiliary cylinder (115) fixed to the body (108) of said pneumatic cylinder (100) which is provided with a first connecting element (116) which is coupled with a second connecting element (117) belonging to a plate (118) fixed to said engine (82).
6. A smoothing - polishing machine (200) according to the claim 3) **characterized in that** said supporting and rotating group (3) of said cylindrical body (2) comprises opposite tailstocks (40) and a motorization group (42) connected to one extremity of said cylindrical body (2), said tailstocks (40) and said motorization group (42) being fixed to said basement (202) of said smoothing - polishing machine (200).
7. A modular smoothing - polishing machine (200) according to the claim 3) or 4) **characterized in that** said cylindrical body (2) is in contact towards a generatrix with a wetting parallel cylinder (31) which get the refrigerating liquid from a basin (32) which insists on said basement (202).
8. A modular smoothing - polishing machine (200) according to the claim 3) **characterized in that** said sliding means comprise:
- vertical sliding means (70) located between the extremity of said frame (51) each one consisting of a plate (71), vertically sliding along the columns (72) fixed to said supporting element (35) and insisting on said basement (202) suited to realize the raising and the lowering of said frame (51);
 - sliding means moving in transversal direction (73) against the longitudinal axis (45) of the cylinder to be smoothed (2) located between the extremity of said frame (51), each one consisting of a slide (74) fixed to said plate (71) which allows the moving of said frame (51) against said plate (71), said vertical sliding means cooperating with vertical handling means (75) and said transversal sliding means cooperating with handling means (76) moving transversally to the cylinder axis to be smoothed.
9. A modular smoothing - polishing machine (200) according to the claim 7) **characterized in that** said vertical handling means (75) comprise a couple of ropes (175), supported by pulleys (375), each rope presenting an end connected to one of said plates (71) of said vertical sliding means (70) and the opposite end rolled up on a rolling up drum (275) which is made turn by an engine.
10. A modular smoothing - polishing machine (200) according to claim 7) **characterized in that** said transversal handling means (76) comprise a couple of ropes (176), supported by pulleys (376), each rope presenting an end connected to one extremity (77) of said frame (51) and the opposite end connected to a rolling up drum (276) which is made turn by an engine (376).
11. A modular smoothing - polishing machine (200) according to the claim 3) **characterized in that** said kinematic elements which move said operating heads (1) comprise sprocket wheels (52) fixed to a central structure (50) insisting on said frame (51), spaced out among them and located on two horizontal and parallel planes where at least one chain (53) is placed in relation of each plane on which such sprocket wheels (52) lie, such a chain being connected as a ring between at least two of said

sprocket wheels (52) with which said chain engages, at least one of said sprocket wheels (52) being connected with rotation means.

12. A modular smoothing - polishing machine (200) according to the claim 11) **characterized in that** each of said operating heads (1) is fixed to said at least one of said chains (53) and it is supported by wheels (91) sliding on rails (92) realized in said central structure (50). 5
13. A modular smoothing - polishing machine (200) according to the claim 3) **characterized in that** each of said connecting means (116, 117) consists of a plurality of protruding metallic points fixed to a support, said metallic points of each connecting element being suitable to realize a mutual friction when they are coupled to avoid sliding among the members which are belonging to. 10 15 20

Patentansprüche

1. Verfahren zum Entfernen von Chromschichten und Gravuren von Tiefdruckzylindern (2) mit einem metallischen Mantel (21), der galvanisch mit einer Kupferschicht (22) beschichtet ist, in die die Gravur eingebracht ist und auf die eine schützende Chrom-Deckschicht (23) aufgebracht ist, **dadurch gekennzeichnet**, daß es folgende Schritte beinhaltet: 25 30
- Versetzen des Zylinders (2) in eine Rotation um seine Längsachse (3), 35
 - Entfernen der Chromschicht (23) mittels zu mindestens einer ersten, vertikal verschiebbaren, sich drehenden Scheibe (4) gehörenden, sich von dieser abhebenden Körpern (41), wobei die sich drehende Scheibe unter einem konstanten Druck gegen die Oberfläche des Tiefdruckzylinders (2) gehalten wird, 40
 - Abflachen der Kupferschicht (22) unterhalb der Chromschicht (23) mittels mindestens einer zweiten, sich drehenden Schleifenelemente aufweisenden Scheibe, wobei das Entfernen der Chrom-Deckschicht (23) bestimmt ist durch das Aufbrechen der Chrom-Deckschicht (23), was durch elastisches Eindringen der unterhalb der Decksicht liegenden Kupferschicht (22) erreicht wird, wenn die abstehenden Körper (41) gegen die Chrom-Deckschicht (23) wirken. 45 50
2. Verfahren nach Anspruch 1, dadurch gekennzeichnet, daß die abstehenden Körper aus Diamantkörnern (41) bestehen, die an der sich drehenden 55

Scheibe mit einem Haftmittel (42) befestigt sind.

3. Modulare Abflach- und Poliermaschine (200) für zylindrische Oberflächen (441), die geeignet ist, das Verfahren zum Entfernen einer Chromschicht gemäß Anspruch 1 zu verwirklichen, mit einem Basiselement (202) welches eine Stütz- und Drehanordnung (3) für einen zu bearbeitenden zylindrischen Körper (2) und eine Abflachanordnung (5) für eine laterale Oberfläche (441) des zylindrischen Körpers (2) trägt, wobei die Abflachgruppe (5) folgende Elemente aufweist:
- Eine Vielzahl von Funktionsköpfen (1), von denen jeder zumindest eine sich drehende Scheibe (4) mit von dieser abstehenden Körpern (41) aufweist und die geeignet sind, die Bearbeitung der lateralen Oberfläche (441) des zylindrischen Körpers (2) auszuführen,
 - Einen die Funktionsköpfe (1) tragenden Rahmen (51), welcher auf an dem Basiselement (202) befestigten Tragelementen (35) ruht und mit den Tragelementen (35) über mit Handhabungsmitteln (75, 76) zusammenwirkenden Gleitmitteln (70, 73) verbunden ist, so daß die Bewegung der Abflachanordnung (5) gegen den zu bearbeitenden zylindrischen Körper (2) ermöglicht wird, **dadurch gekennzeichnet**, daß die Funktionsköpfe (1) mit durch den Rahmen (51) getragenen kinematischen Elementen (52, 53) zur Bewegung der Funktionsköpfe (1) entlang einer longitudinalen, im wesentlichen zu den Erzeugenden der abzuflachenden lateralen Oberfläche (441) des zylindrischen Körpers (2) parallelen Richtung (45) verbunden sind, wobei jeder der Funktionsköpfe (1) mit einer Oszilationsanordnung (8) versehen ist, die dazu geeignet ist, die Bewegung der zu jedem der Funktionsköpfe (1) gehörenden sich drehenden Scheibe (4) in eine im wesentlichen vertikale Richtung zeitgleich zu der Bewegung eines jeden der Köpfe entlang der longitudinalen Richtung (45) zu ermöglichen, um einen konstanten Andruck der sich drehenden Scheiben (4) gegen die abzuflachende Oberfläche zu halten.
4. Modulare Abflach- und Poliermaschine (200) gemäß Anspruch 3, dadurch gekennzeichnet, daß jeder Funktionskopf (1) einen Motor (82) aufweist, der über Antriebsmittel (83) mit einem an dem kinematischen Elementen (53) fest angeordneten Träger (81) beweglich verbunden ist, und daß die Oszilationsanordnung (8) an ihm angeordnet ist, welche einen pneumatischen Zylinder (100) aufweist, dessen Stempel (109) mit dem Motor (82) fest verbunden ist und dessen Körper (108) mittels einer Klam-

- mer (111) mit der Struktur (81) fest verbunden ist, wobei der Körper (108) ein Innengewinde (110) aufweist, mit welchem eine Schraube (113) verbunden ist, welche mit einem durch einen Vierkant (112) mit der Klammer (111) fest verbundenen Motor (114) verbunden ist, wobei Befestigungsmittel vorgesehen sind, die eine feste Verbindung zwischen dem Körper (108) des Pneumatikzylinders (100) und dem Motor (82) bewirken.
- 5
5. Modulare Abflach- und Poliermaschine (200) gemäß Anspruch 4, dadurch gekennzeichnet, daß das Befestigungsmittel einen mit dem Körper (108) des Pneumatikzylinder (100) fest verbundenen pneumatischen Hilfszylinder (115) aufweist, welcher ein erstes Verbindungselement (116) aufweist, das mit einem zweiten, zu einer mit dem Motor (82) fest verbundenen Platte (118) gehörenden Verbindungselement (117) verbunden ist.
- 10
6. Modulare Abflach - und Poliermaschine (200) gemäß Anspruch 3, dadurch gekennzeichnet, daß die Stütz- und Drehanordnung (3) für den zylindrischen Körper (2) gegenüberliegend angeordnete Reitstöcke (40) und eine Motorisierungsanordnung (42) aufweist, die mit einem Ende des zylindrischen Körpers (2) verbunden ist, wobei die Reitstöcke (40) und die Motorisierungsgruppe (42) mit dem Basiselement (202) der Abflach- und Poliermaschine (200) fest verbunden sind.
- 15
7. Modulare Abflach - und Poliermaschine (200) gemäß Anspruch 3 oder 4, dadurch gekennzeichnet, daß der zylindrische Körper (2) mit einem parallelen Benetzungszylinder (31) in Richtung einer Erzeugenden in Kontakt ist, der eine Kühllösung aus einem Becken (32) erhält, welches auf dem Basiselement (202) ruht.
- 20
8. Modulare Abflach - und Poliermaschine (200) gemäß Anspruch 3, dadurch gekennzeichnet, daß die Gleitmittel folgendes aufweisen:
- 25
- vertikale Gleitmittel (70), die an den äußeren Enden des Rahmens (51) angeordnet sind, und jeweils eine Platte (71), die vertikal entlang mit dem Stützelement (35) verbundenen Säulen (75) gleiten enthalten und auf dem Basiselement (202) ruhen, um ein Heben und Absenken des Rahmens (51) zu ermöglichen,
 - Gleitmittel, die in transversaler Richtung (73) gegen die Längsachse (45) des abzuflachenden Zylinders (2) beweglich sind und an den äußeren Enden des Rahmens (51) angeordnet sind, wobei jedes aus einem mit der Platte (71) fest verbundenen Gleitstück (74) besteht, welches eine Bewegung des Rahmens (51) gegen
- 30
- die Platte (71) ermöglicht, wobei die vertikalen Gleitmittel mit vertikalen Handhabungsmitteln (75) zusammenwirken und die transversalen Gleitmittel, die transversal auf die Achse des abzuflachenden Zylinders zu beweglich sind, mit Handhabungsmitteln (76) zusammenwirken.
- 35
9. Modulare Abflach- und Poliermaschine (200) gemäß Anspruch 7, dadurch gekennzeichnet, daß die vertikalen Handhabungsmittel (75) eine Vielzahl von über Rollen (375) geführte Seile (175) aufweisen, wobei jedes Seil ein mit einer der Platten (71) der vertikalen Gleitmittel (70) verbundenes Ende aufweist und wobei ein entgegengesetztes Ende auf einer Aufrolltrommel (275) aufgewickelt ist, die durch einen Motor drehbar angetrieben ist.
- 40
10. Modulare Abflach - und Poliermaschine (200) gemäß Anspruch 7, dadurch gekennzeichnet, daß die transversalen Handhabungsmittel (76) eine Vielzahl von über Rollen (376) geführten Seilen (176) aufweisen, wobei jedes Seil ein mit einem äußeren Ende (77) des Rahmens (51) verbundenes Ende aufweist und wobei ein entgegengesetztes Ende mit einer Aufrolltrommel (276) verbunden ist, welche durch einen Motor (376) drehbar angetrieben ist.
- 45
11. Modulare Abflach - und Poliermaschine (200) gemäß Anspruch 3, dadurch gekennzeichnet, daß die kinematischen Elemente, welche die Funktionsköpfe (1) bewegen, mit einer auf dem Rahmen (51) angeordneten zentralen Struktur (50) fest verbundene Zahnkränze (52) aufweisen, die zwischen diesen verteilt sind und in zwei horizontalen und parallelen Ebenen angeordnet sind, wobei mindestens jeweils eine Kette (53) in Beziehung zu jeweils einer dieser Ebenen, in welchen die Zahnkränze (52) liegen, angeordnet ist, wobei eine solche Kette zwischen zumindest zwei der Zahnkränze (52), mit welchen die Kette in Eingriff steht, ringförmig verbunden ist und wobei zumindest einer der Zahnkränze (52) mit einem Rotationsmittel verbunden ist.
- 50
12. Modulare Abflach - und Poliermaschine (200) gemäß Anspruch 11, dadurch gekennzeichnet, daß jeder der Funktionsköpfe (1) mit der mindestens einen Kette (53) verbunden ist und durch Räder (91) gestützt wird, welche auf Schienen (92) gleiten, die in der zentralen Struktur (50) ausgeformt sind.
- 55
13. Modulare Abflach - und Poliermaschine (200) gemäß Anspruch 3, dadurch gekennzeichnet, daß jedes der Verbindungsmittel (116, 117) aus einer Vielzahl von überstehenden, mit einem Träger verbundenen, metallischen Elementen bestehen, wobei die metallischen Elemente eines jeden Verbind-

dingselementes geeignet sind, um eine wechselseitige Reibung zu erzeugen, wenn sie miteinander verbunden sind, um ein Abgleiten der Glieder, zu denen sie gehören, zu verhindern.

Revendications

1. Procédé pour enlever le placage de chrome et la gravure de rouleaux gravés (2), constituée d'une enveloppe métallique (21) revêtue galvaniquement d'un revêtement de cuivre (22) sur lequel ladite gravure est effectuée et un recouvrement de chrome de protection (23) est établi galvaniquement, caractérisé en ce qu'il comporte les opérations suivantes :

- amener ledit cylindre (2) à tourner autour de son axe longitudinal (3),
- enlever ledit recouvrement de chrome (23) par des corps de contrastes (41) appartenant à au moins un premier disque rotatif (4) pouvant être déplacé verticalement alors que le disque rotatif est maintenu avec une pression constante contre la surface du rouleau gravé (2),
- lisser ledit revêtement de cuivre (22) situé en-dessous dudit recouvrement de chrome (23), par au moins un second disque rotatif muni d'éléments abrasifs, ledit enlèvement dudit recouvrement de chrome (23) étant déterminé par la rupture du recouvrement de chrome (23) qui est obtenue par l'écrasement élastique du revêtement de cuivre (22) situé dessous lorsque lesdits corps de contrastes (41) interfèrent contre ledit recouvrement de chrome (23).

2. Procédé selon la revendication 1, caractérisé en ce que lesdits corps de contrastes sont constitués de granulés de diamant (41) qui sont fixés dans le disque rotatif par un agent de fixation (42).

3. Machine de lissage-polissage modulaire (200) pour surfaces cylindriques (441) adaptée pour mettre en oeuvre le procédé d'enlèvement du placage de chrome selon la revendication 1 comportant une base (202) qui supporte un support et un groupe rotatif (3) constitué d'un corps cylindrique (2) à usiner et un groupe de lissage (5) de la surface latérale (441) dudit corps cylindrique (2), ledit groupe de lissage (5) comportant :

- une pluralité de têtes actives (1), chacune d'elles étant munie d'au moins un disque rotatif (4) ayant des corps de contrastes (41) adaptés pour réaliser l'usinage de la surface latérale (441) dudit corps cylindrique (2),
- un châssis (51) supportant lesdites têtes actives (1) et qui est supporté par des éléments de

support (35) fixés sur ladite base (202) et est relié aux-dits éléments de support (35) par des moyens coulissants (70, 73) coopérant avec des moyens de manipulation (75, 76) adaptés pour obtenir le déplacement dudit groupe de lissage (5) contre ledit corps cylindrique (2) à usiner, caractérisé en ce que lesdites têtes actives (1) sont reliées à des éléments cinématiques (52, 53) supportés par ledit châssis (51) pour déplacer lesdites têtes actives (1) selon une direction longitudinales (45) sensiblement parallèle aux génératrices de la surface latérale (441) dudit corps cylindrique (2) à lisser, chacune desdites têtes actives (1) étant munie d'un groupe d'oscillation (8) adapté pour réaliser le déplacement du disque rotatif (4) appartenant à chacun d'eux, dans une direction sensiblement verticale, simultanément au déplacement de chacune desdites têtes selon ladite direction longitudinale (45) pour maintenir une pression constante des disques rotatifs (4) contre la surface à lisser.

4. Machine de lissage-polissage modulaire (200) selon la revendication 3, caractérisée en ce que chaque tête active (1) comporte un moteur (82) relié de manière douce par des moyens d'entraînement (83) à un support (81), fixé sur lesdits éléments cinématiques (53) et muni dudit groupe d'oscillation (8) qui comporte un vérin pneumatique (100) dont la tige (109) est fixée sur ledit moteur (82) et dont le corps (108) est fixé par un étrier (111) sur ladite structure (81), ledit corps (108) étant muni d'un filet femelle (110) avec lequel une vis (113) est accouplée en appartenant à un moteur (114) fixé par un carré (112) sur ledit étrier (111), des moyens de blocage étant réalisés de manière adaptée pour une liaison fixe entre ledit corps (108) dudit vérin pneumatique (100) et ledit moteur (82).

5. Machine de lissage-polissage modulaire (200) selon la revendication 4, caractérisée en ce que les moyens de blocage comportent un vérin auxiliaire pneumatique (115) fixé sur le corps (108) du vérin pneumatique (100) qui est muni d'un premier élément de liaison (116) qui est relié à un second élément de liaison (117) appartenant à une plaque (118) fixée sur ledit moteur (82).

6. Machine de lissage-polissage modulaire (200) selon la revendication 3, caractérisée en ce que ledit groupe de support rotatif (3) dudit corps cylindrique (2) comporte des contre-pointes opposées (40) et un groupe de motorisation (42) relié à une première extrémité dudit corps cylindrique (2), lesdites contre-pointes et ledit groupe de motorisation (42) étant fixés sur ladite base (202) de ladite machine de lissage-polissage (200).

7. Machine de lissage-polissage modulaire (200) selon la revendication 3 ou 4, caractérisée en ce que ledit corps cylindrique (2) est en contact vers une génératrice avec un cylindre parallèle d'humectage (31) qui prend le liquide de réfrigération dans un bassin (32) qui est en appui sur ladite base (202). 5
8. Machine de lissage-polissage modulaire (200) selon la revendication 3, caractérisée en ce que lesdits moyens coulissants comportent : 10
- des moyens de coulissement vertical (70) positionnés entre l'extrémité dudit châssis (51), chacun étant constitué d'une plaque (71), coulissant verticalement le long des colonnes (72) fixées sur ledit élément de support (35) et en appui sur ladite base (202) adaptée pour réaliser le levage et l'abaissement dudit châssis (51), 15
 - des moyens de coulissement se déplaçant dans une direction transversale (73) contre l'axe longitudinal (45) du cylindre à lisser (2), positionnés aux extrémités dudit châssis (51), chacun étant constitué d'un coulissant (74) fixé sur ladite plaque (71) qui permet le déplacement dudit châssis (51) contre ladite plaque (71), lesdits moyens de coulissement vertical coopérant avec les moyens de manipulation verticale (75) et lesdits moyens de coulissement transversal coopérant avec les moyens de manipulation (76) se déplaçant transversalement à l'axe du cylindre à lisser. 20 25 30
9. Machine de lissage-polissage modulaire (200) selon la revendication 7, caractérisée en ce que lesdits moyens de manipulation verticale (75) comportent un couple de câbles (175), supporté par des poulies (375), chaque câble présentant une extrémité reliée à une desdites plaques (71) desdits moyens de coulissement vertical (70) et une extrémité opposée roulée sur un tambour d'enroulement (275) qui est amené à tourner par un moteur. 35 40
10. Machine de lissage-polissage modulaire (200) selon la revendication 7, caractérisée en ce que lesdits moyens de manipulation transversale (76) comportent un couple de câbles (176) supporté par des poulies (376), chaque câble présentant une extrémité reliée à une extrémité (77) dudit châssis (51) et une extrémité opposée reliée à un tambour d'enroulement (276) qui est amené à tourner par un moteur (376). 45 50
11. Machine de lissage-polissage modulaire (200) selon la revendication 3, caractérisée en ce que lesdits éléments cinématiques qui déplacent lesdites têtes actives (1) comprennent des roues dentées (52) fixées sur une structure centrale (50) en appui 55
- sur ledit châssis (51), espacées entre elles et positionnées sur deux plans horizontaux et parallèles où au moins une chaîne (53) est placée par rapport à chaque plan sur lesquels se trouvent de telles roues dentées (52) de sorte qu'une chaîne est reliée sous forme d'un anneau entre au moins deux desdites roues dentées (52) avec lesquelles ladite chaîne coopère, au moins une desdites roues dentées (52) étant reliée à des moyens de mise en rotation.
12. Machine de lissage-polissage modulaire (200) selon la revendication 11, caractérisée en ce que chacune desdites têtes actives (1) est fixée sur ladite au moins une desdites chaînes (53) et est supportée par des roues (91) coulissant sur des rails (92) réalisés dans ladite structure centrale (50).
13. Machine de lissage-polissage modulaire (200) selon la revendication 3, caractérisée en ce que chacun desdits moyens de liaison (116, 117) est constitué d'une pluralité de points métalliques en saillie fixés sur un support, lesdits points métalliques de chaque élément de liaison étant adaptés pour réaliser une friction mutuelle lorsqu'ils sont accouplés pour éviter un coulissement entre les éléments auxquels ils appartiennent.

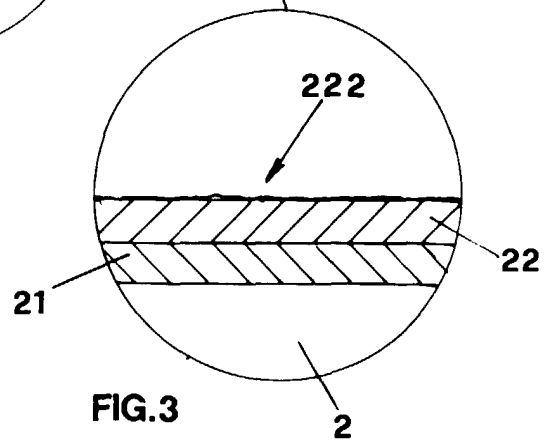
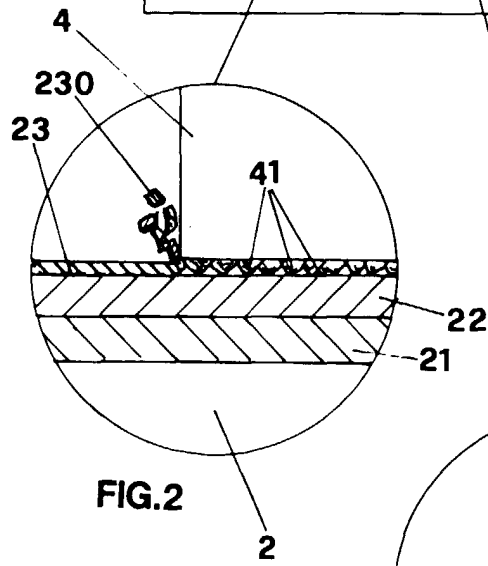
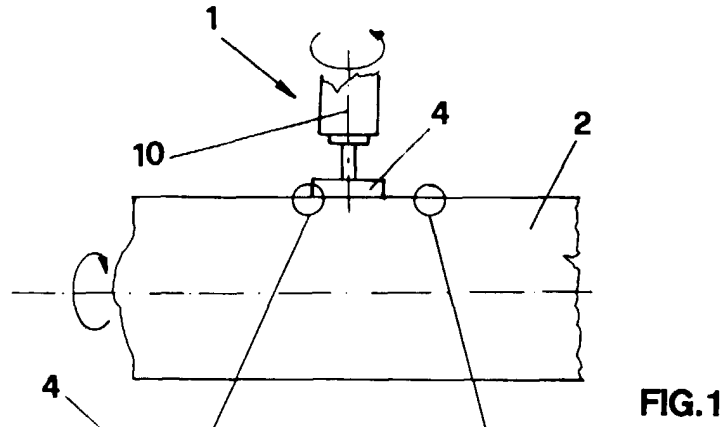

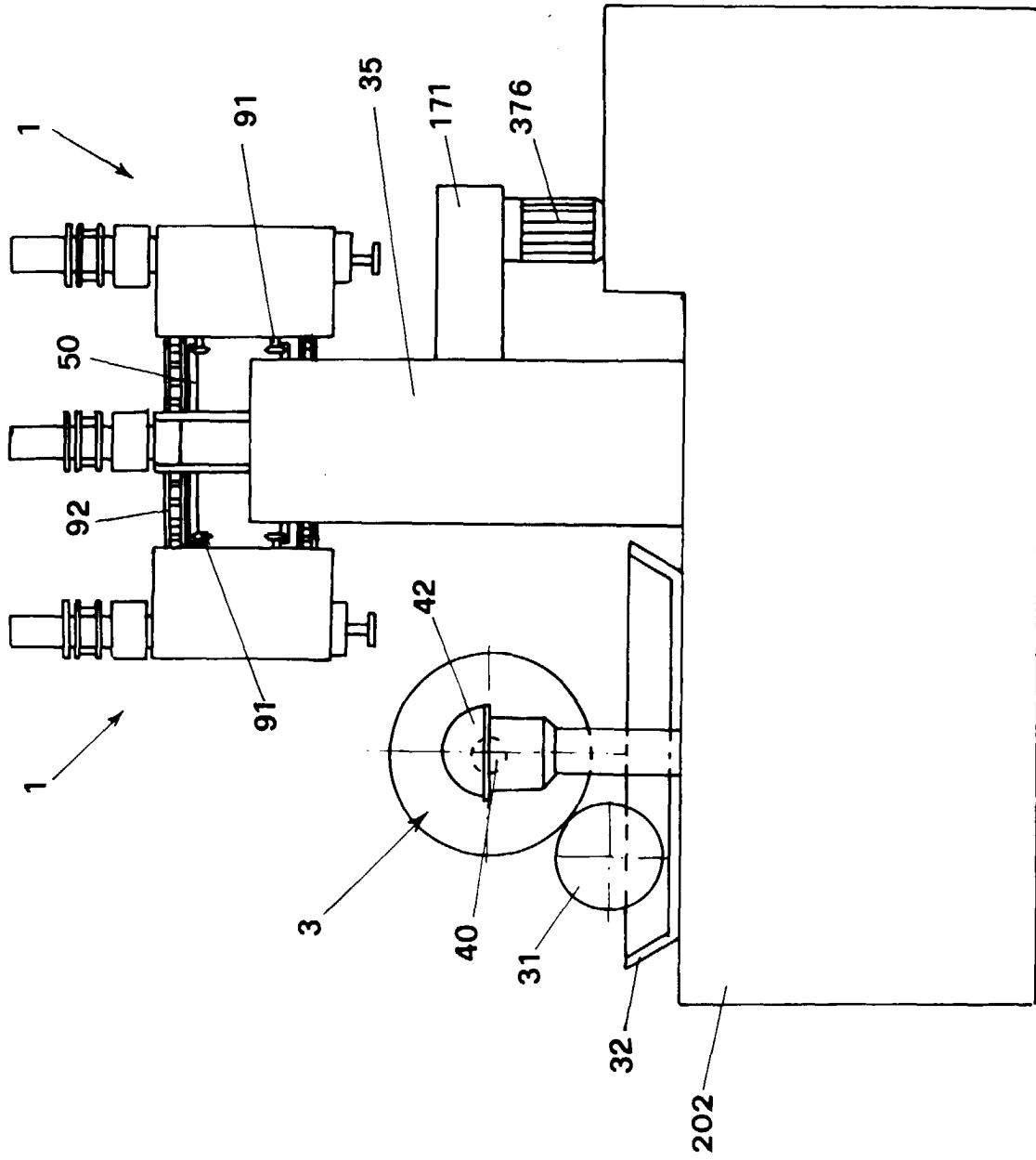

FIG.5

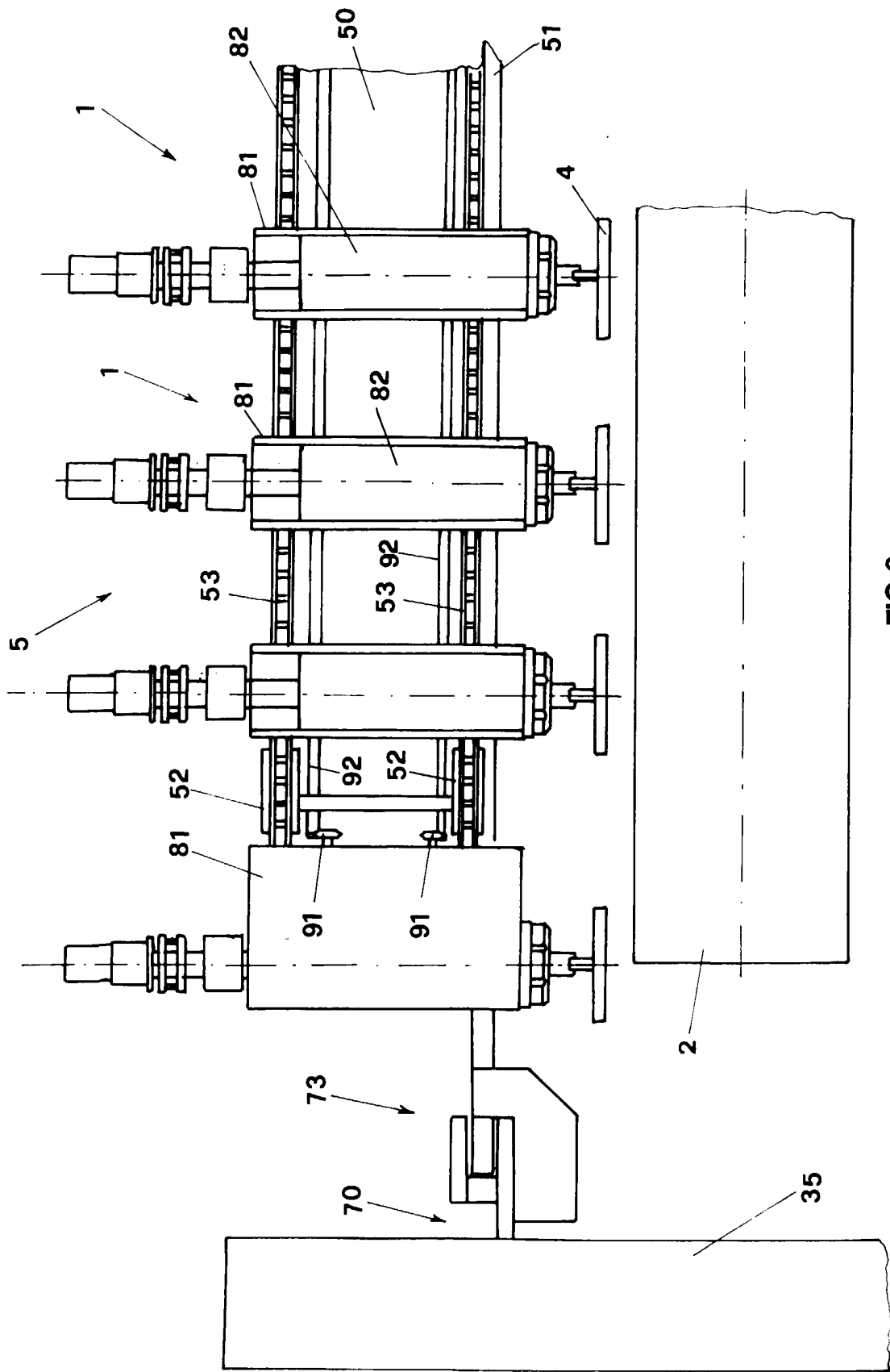
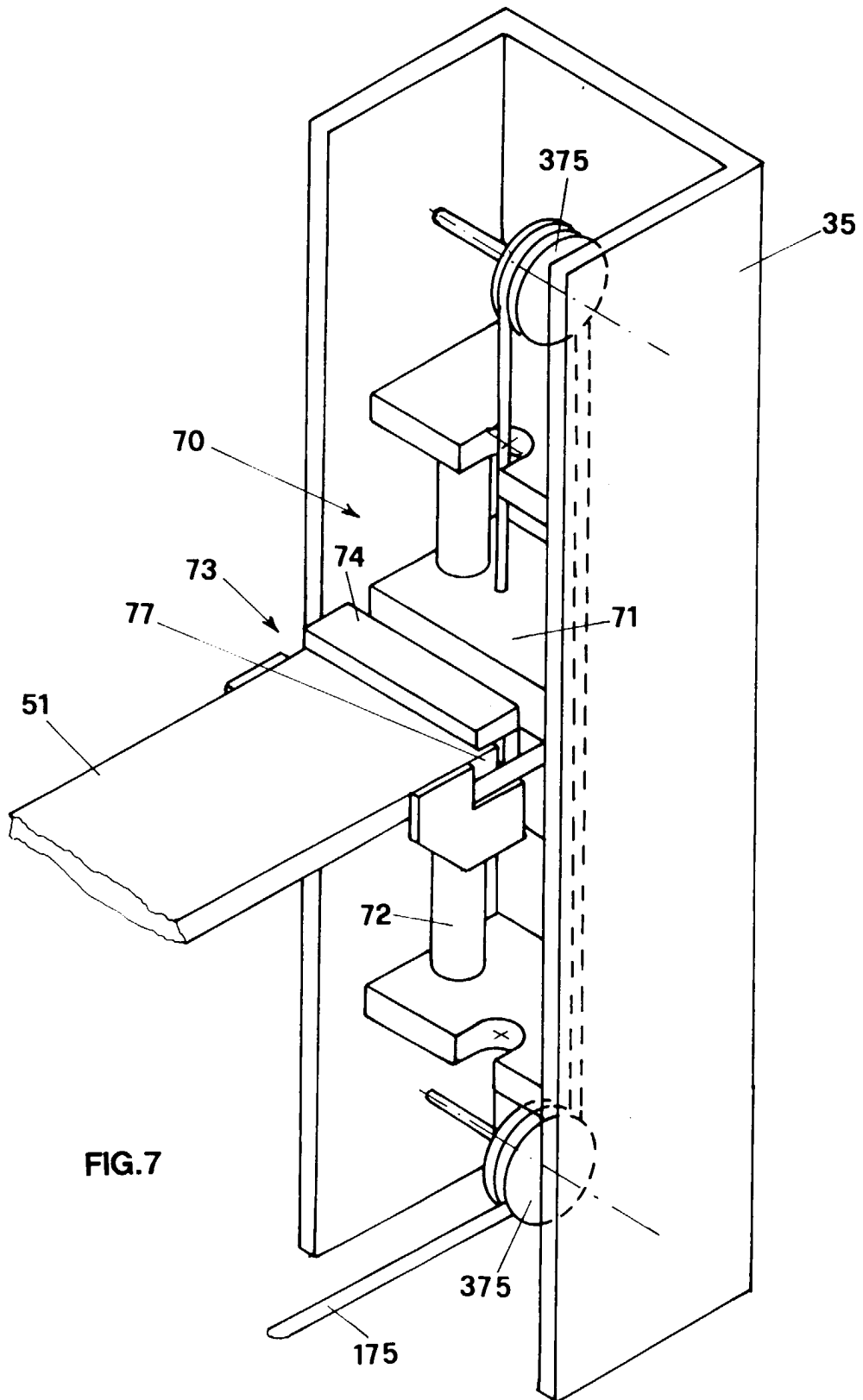
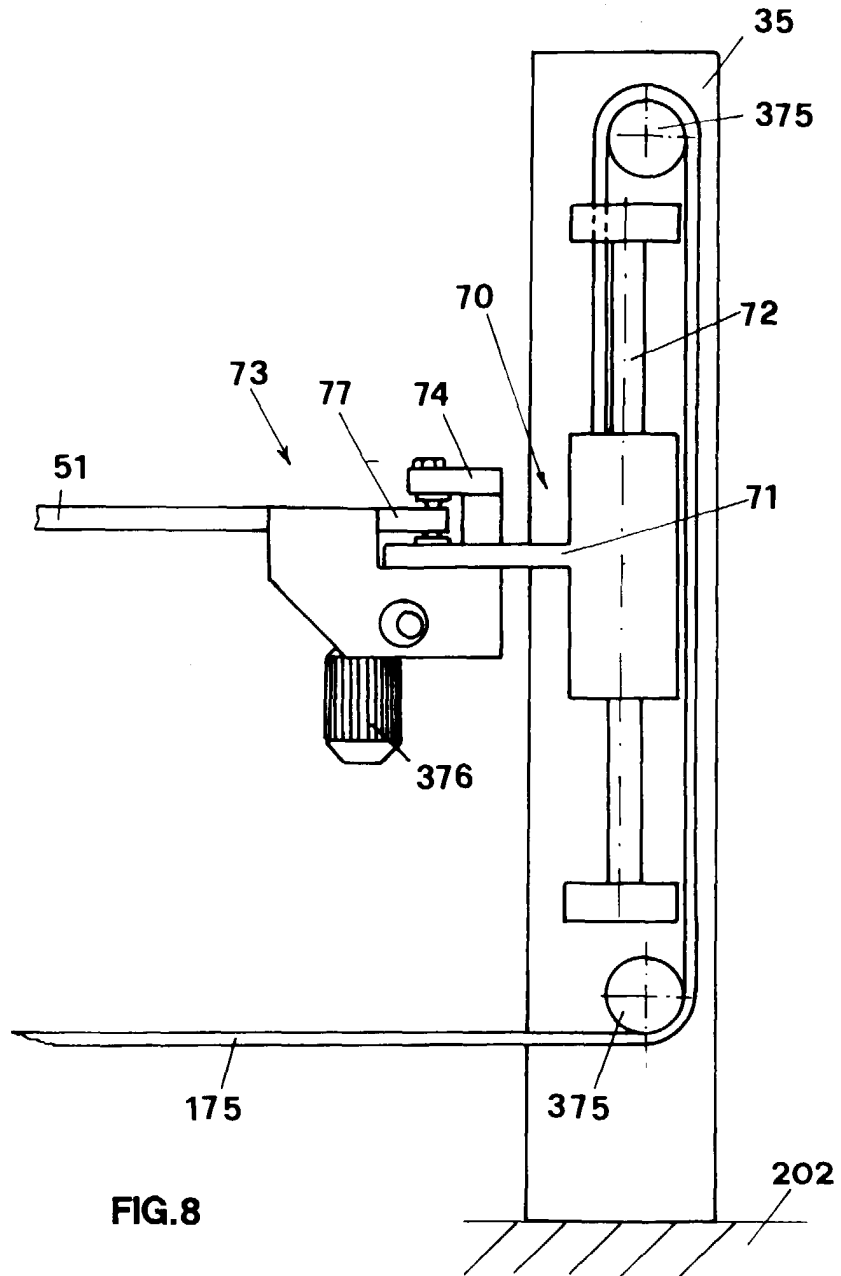
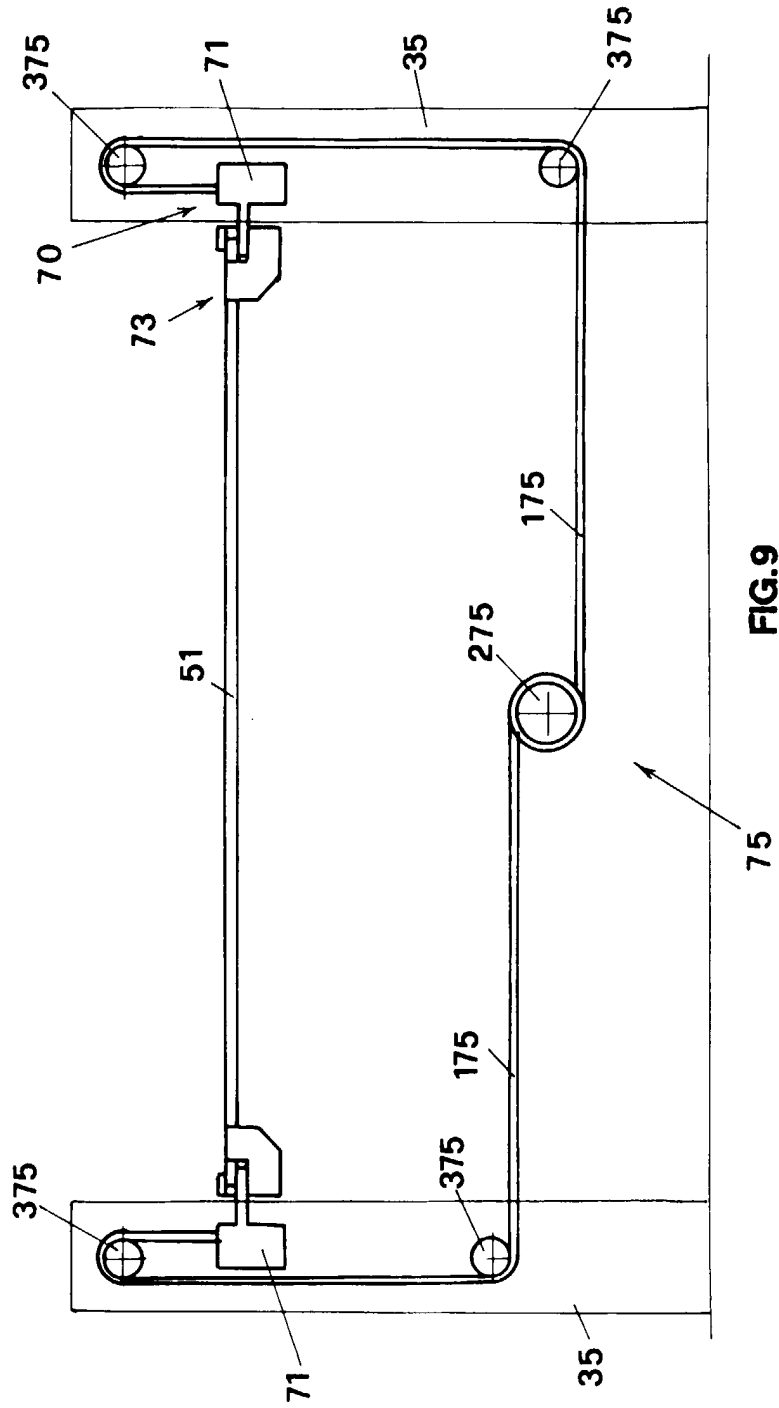
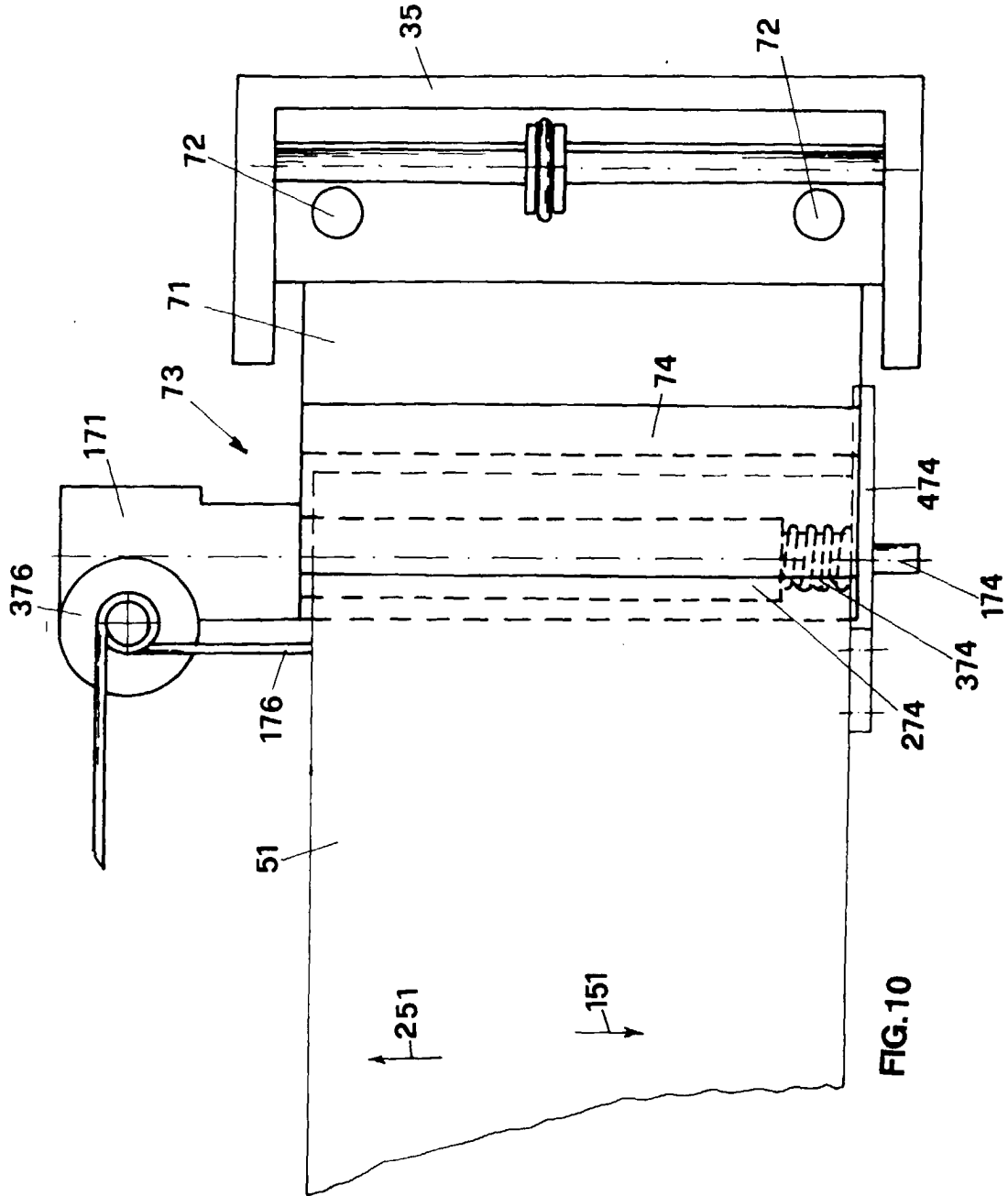

FIG. 6









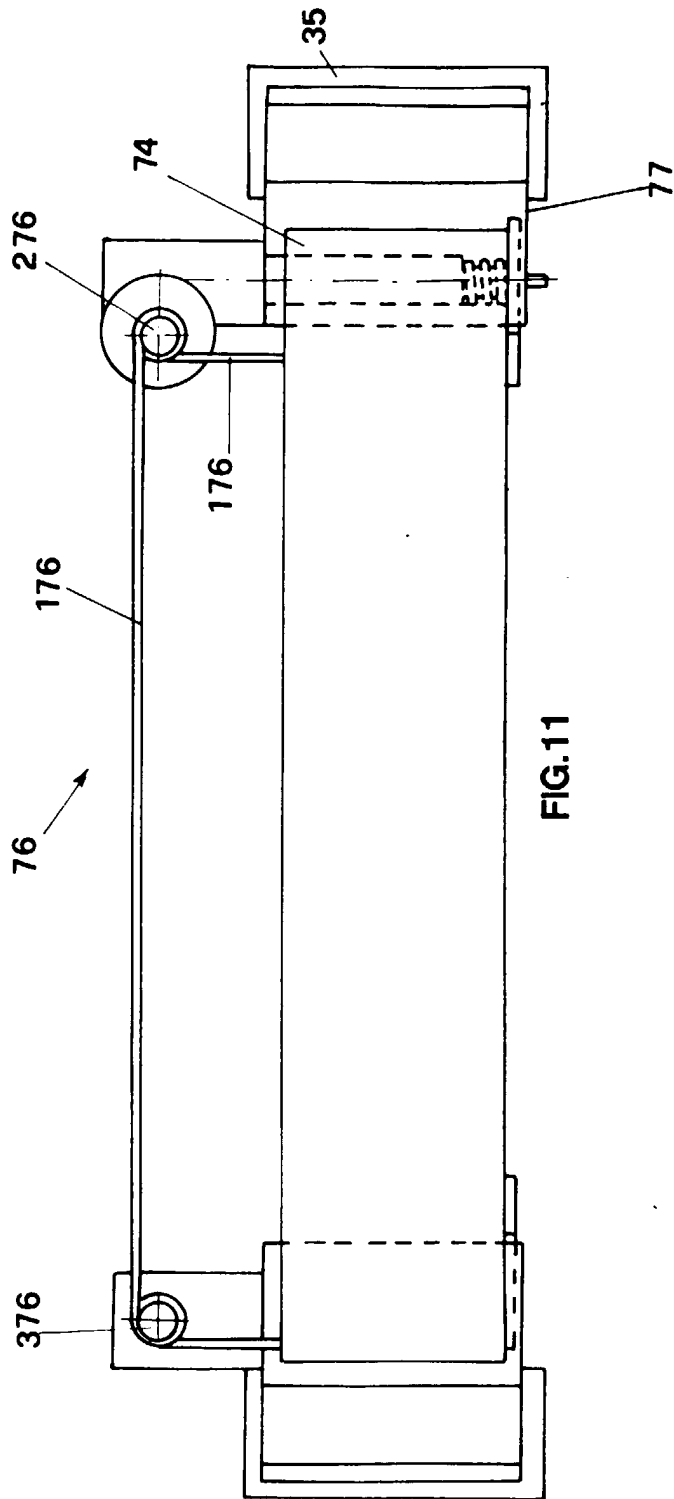

FIG. 11

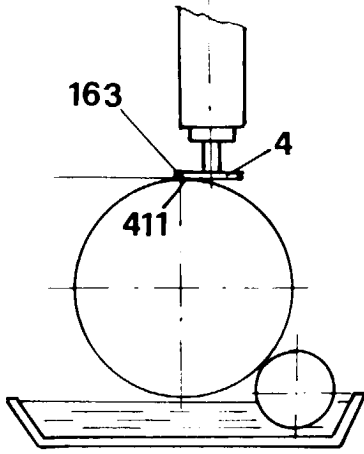

FIG. 13

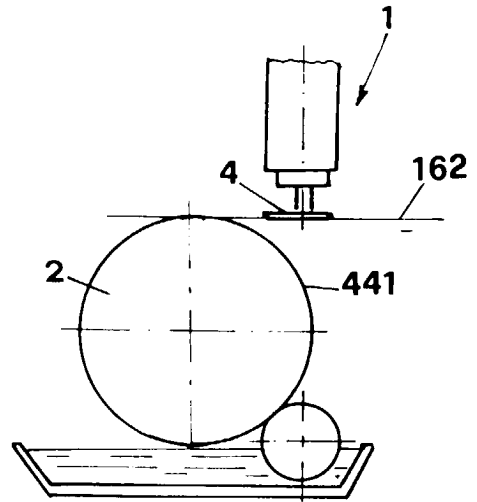

FIG. 12

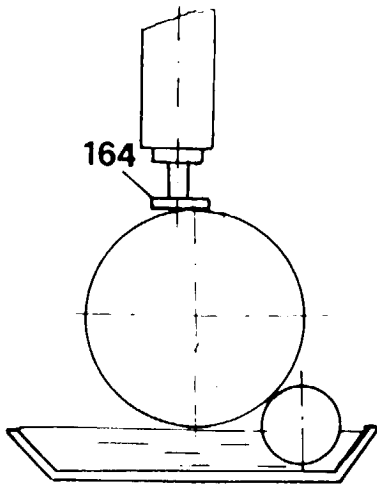

FIG. 14

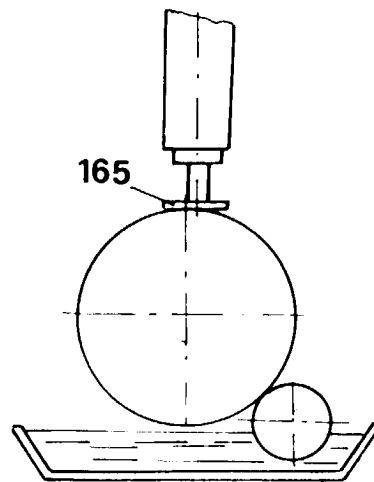

FIG. 15

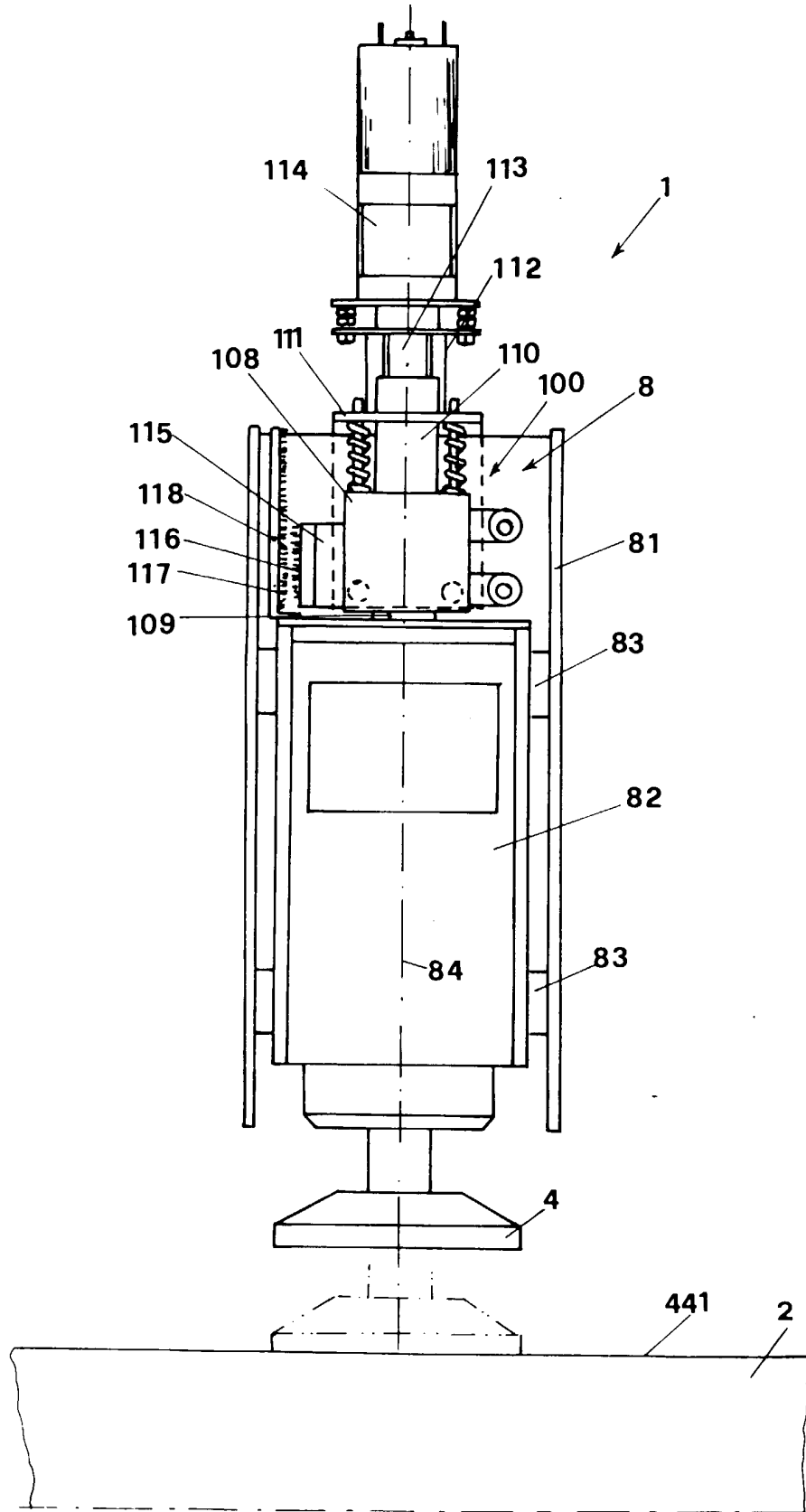

FIG. 16

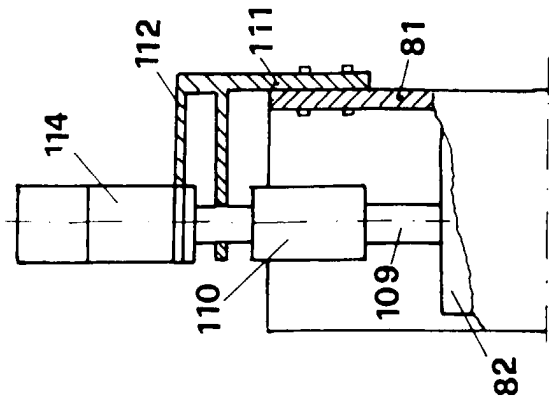

FIG. 19

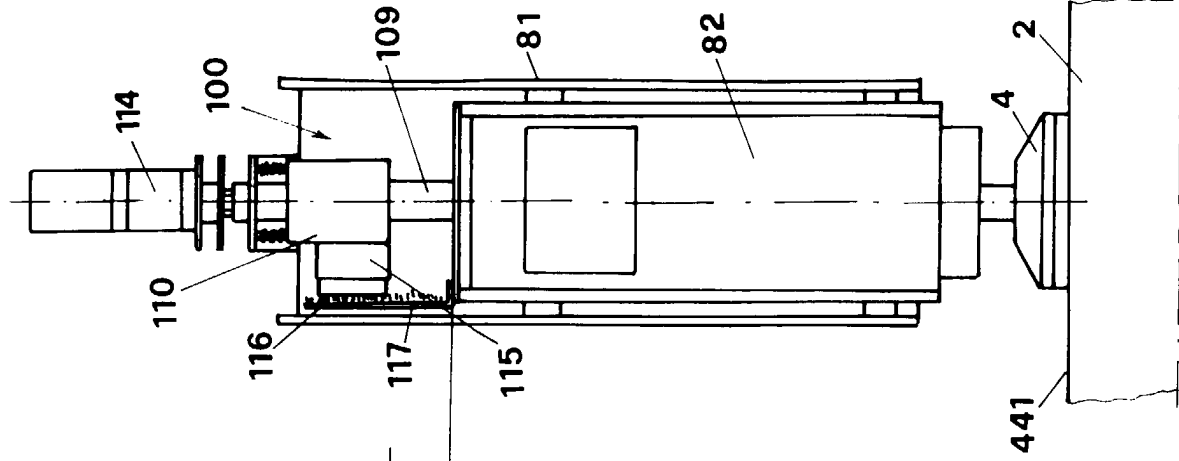

FIG. 18

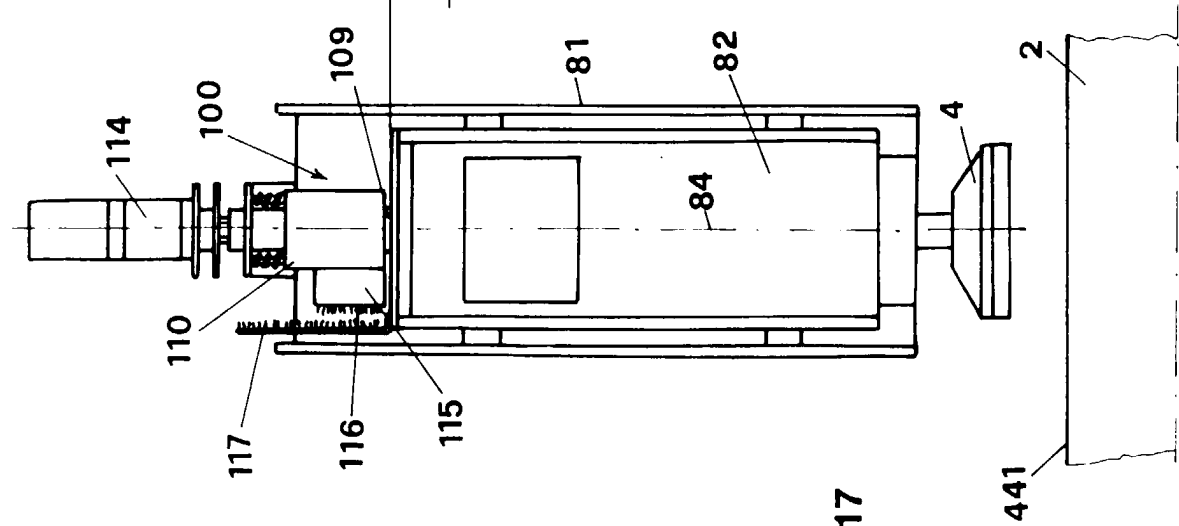

FIG. 17