



Europäisches Patentamt
European Patent Office
Office européen des brevets



(11) **EP 0 811 535 A3**

(12) **EUROPEAN PATENT APPLICATION**

(88) Date of publication A3:
04.10.2000 Bulletin 2000/40

(51) Int. Cl.⁷: **B60R 22/415**

(43) Date of publication A2:
10.12.1997 Bulletin 1997/50

(21) Application number: **97109088.1**

(22) Date of filing: **05.06.1997**

(84) Designated Contracting States:
**AT BE CH DE DK ES FI FR GB GR IE IT LI LU MC
NL PT SE**

(72) Inventor:
**Sumiyashiki, Akira,
K.K. Tokai-Rika-Denki
Ohguchi-cho, Niwa, Aichi-ken (JP)**

(30) Priority: **06.06.1996 JP 14408896
04.03.1997 JP 4935097**

(74) Representative:
**Dreiss, Fuhlendorf, Steimle & Becker,
Patentanwälte
Postfach 10 37 62
70032 Stuttgart (DE)**

(71) Applicant:
**KABUSHIKI KAISHA TOKAI-RIKA-DENKI-
SEISAKUSHO
Niwa Aichi-ken (JP)**

(54) **Webbing retractor**

(57) A webbing retractor comprises: a winding shaft (14) onto which a webbing (11) used for restraining a vehicle occupant is wound; locking means (32) which is actuated to stop rotation of the winding shaft in a direction in which the webbing is pulled out; an ALR lever (94) which can be moved at an operating position where the locking means is actuated and at a non-operating position where the locking means is not actuated, and which is usually urged toward the operating position by urging force; a cam member (50) to which rotation of the winding shaft is transmitted via a gear mechanism (26,62,66,52) so as to hold the ALR lever (94) at the non-operating position from a first state in which the webbing is wound onto the winding shaft substantially to its full length to a second state immediately before the webbing is pulled out substantially to its full length and also set the ALR lever (94) in a state of being movable to the operating position; and stopping means (70) to which rotation of the winding shaft is transmitted via the gear mechanism, the stopping means holding the ALR lever at the non-operating position from the second state to the third state and allowing movement of the ALR lever at the operating position by the urging force when the winding shaft is rotated, from the third state, in a direction in which the webbing is wound, the direction being opposite to the direction in which the webbing is pulled out. Accordingly, the ALR lever (94) is held at the non-operating position by the stopping means (70) from the second state to the third state, and therefore, the webbing can be pulled out to its full length without stop-

ping rotation of the winding shaft in the direction in which the webbing is pulled out.

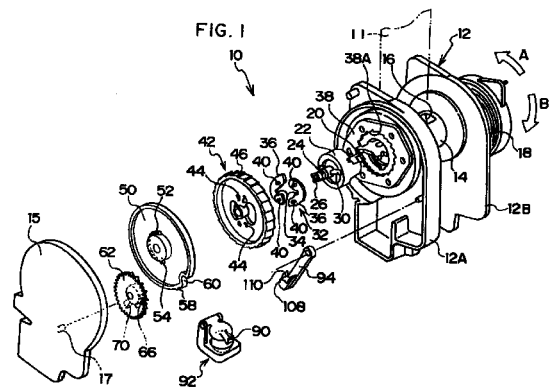

EP 0 811 535 A3



European Patent
Office

EUROPEAN SEARCH REPORT

Application Number
EP 97 10 9088

DOCUMENTS CONSIDERED TO BE RELEVANT			
Category	Citation of document with indication, where appropriate, of relevant passages	Relevant to claim	CLASSIFICATION OF THE APPLICATION (Int.Cl.6)
X	US 4 566 649 A (PETERSEN III CARL M) 28 January 1986 (1986-01-28) * the whole document *	1,4,9, 11,15	B60R22/415
Y	---	12-14	
A	---	5	
Y	US 3 806 678 A (QUINTING R ET AL) 23 April 1974 (1974-04-23) * abstract; figures 2,3 * * column 3, line 54 - column 4, line 32 * * column 4, line 62 - column 5, line 12 *	12-14	
X	US 5 505 400 A (BOELSTLER RICHARD A ET AL) 9 April 1996 (1996-04-09) * the whole document *	1,2,9, 11,15	TECHNICAL FIELDS SEARCHED (Int.Cl.6) B60R
A	---	3,10	
A	US 3 853 284 A (HASEGAWA T ET AL) 10 December 1974 (1974-12-10) * abstract; figures * -----	12-14	
The present search report has been drawn up for all claims			
Place of search THE HAGUE		Date of completion of the search 3 August 2000	Examiner Dubois, B
CATEGORY OF CITED DOCUMENTS X : particularly relevant if taken alone Y : particularly relevant if combined with another document of the same category A : technological background O : non-written disclosure P : intermediate document		T : theory or principle underlying the invention E : earlier patent document, but published on, or after the filing date D : document cited in the application L : document cited for other reasons & : member of the same patent family, corresponding document	

EPO FORM 1503 03.02 (P04C01)

**ANNEX TO THE EUROPEAN SEARCH REPORT
ON EUROPEAN PATENT APPLICATION NO.**

EP 97 10 9088

This annex lists the patent family members relating to the patent documents cited in the above-mentioned European search report. The members are as contained in the European Patent Office EDP file on
The European Patent Office is in no way liable for these particulars which are merely given for the purpose of information.

03-08-2000

Patent document cited in search report	Publication date	Patent family member(s)	Publication date
US 4566649 A	28-01-1986	NONE	
US 3806678 A	23-04-1974	NONE	
US 5505400 A	09-04-1996	NONE	
US 3853284 A	10-12-1974	NONE	

EPO FORM P0450

For more details about this annex : see Official Journal of the European Patent Office, No. 12/82