



Europäisches Patentamt  
 European Patent Office  
 Office européen des brevets



(11) **EP 0 811 563 A1**

(12) **EUROPEAN PATENT APPLICATION**

(43) Date of publication:  
 10.12.1997 Bulletin 1997/50

(51) Int. Cl.<sup>6</sup>: **B65D 83/44**, B65D 83/56

(21) Application number: **96201604.4**

(22) Date of filing: **08.06.1996**

(84) Designated Contracting States:  
**AT BE CH DE DK ES FI FR GB GR IE IT LI LU NL  
 PT SE**

• **Rogers, Neil John**  
 1020 Brussel (BE)

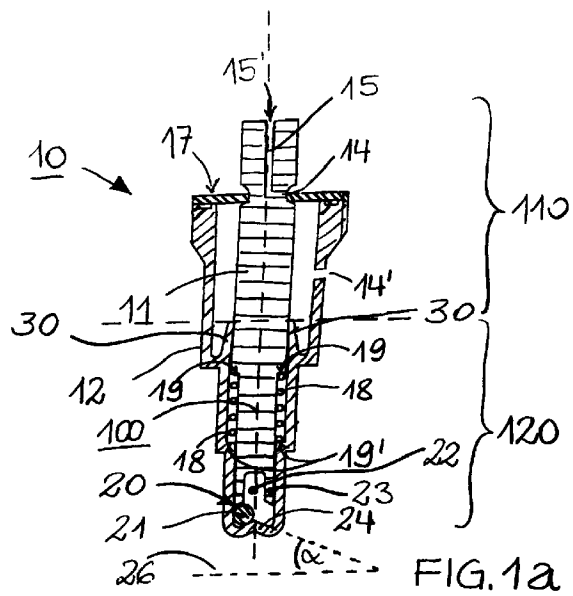
(71) Applicant:  
**THE PROCTER & GAMBLE COMPANY**  
 Cincinnati, Ohio 45202 (US)

(74) Representative:  
**Mather, Peter Geoffrey et al**  
**Procter & Gamble**  
**European Technical Center N.V.**  
**Temseleen 100**  
**1853 Strombeek-Bever (BE)**

(72) Inventors:  
 • **Oder, Rueben**  
 1785 Hamme (BE)

(54) **A valve for pressurized containers**

(57) The present invention provides a valve (10) comprising a stem (11), a housing (12) and a blocking means (20). The stem (11) is movable within the housing (12) to allow the opening and the closing of the valve (10). The stem (11) comprises a discharging opening (14) connected to a discharging channel (15), whereby the discharging channel (15) is located on one end of the stem (11). The housing comprises an orifice. The blocking means (20) prevents the opening of the valve (10) when the discharging channel (15) is in an undesired orientation. The blocking means is separated from the discharging opening (14). The blocking means (20) is located at the other end of the stem (11) opposed to the discharging channel (15).



EP 0 811 563 A1

## Description

The present invention relates to a valve for a pressurized container.

A pressurized container usually contains a product together with a propellant. The propellant usually creates the necessary pressure inside the container. The propellant may be a liquid or a gaseous propellant. When the propellant is a liquid propellant, the pressure inside the container is created by the vapour pressure of the liquid propellant. The gaseous propellant and the vapour phase of the liquid propellant are usually located in the headspace of the container when the container stands in its upright position. The pressure inside the container is higher than the normal outside atmospheric pressure. The inside pressure of the container is maintained by closing the container with a valve. Consequently, the propellant tends to exit from the inside of the container once the valve of the container is opened. Thereby the propellant also drives the product out of the container.

In order that all of the product can be expelled out of the container it has to be ensured that enough propellant is available in the container with respect to the amount of product. Consequently, it has to be ensured that the propellant is not allowed to exit unnecessarily, i.e. the product must be expelled at the same time as the propellant. If product is not expelled at the same time as the propellant, the propellant may be progressively emptied out of the pressurized container until the remaining amount of propellant may become too low with respect to the rest of product remaining in the container to ensure the complete dispensing of the rest of product from inside the pressurized container. The rest of the product which cannot be expelled from inside the pressurized container is then wasted. Other possible drawbacks of propellant exiting unnecessarily from the container are deterioration of the characteristics of the expelled product. For example, when the product is a foaming product, the density of the foam may increase in an undesirable manner.

The discharge of propellant without product may happen whenever the product is not placed between the propellant and the discharging opening of the pressurized container. Indeed, it has to be ensured that the propellant is obliged to pass through the product pushing at least part of the product out of the pressurized container. This undesirable positioning of the propellant with respect to the product and the discharging opening of the pressurized container may be reached when the pressurized container is allowed to discharge in an undesired direction.

For example, when the pressurized container comprises a dip tube connecting the discharging opening at the top of the container with the inside of the pressurized container, the undesired direction would be to invert the pressurized container, i.e. to turn it upside down. In this position the gaseous propellant in the headspace is capable of escaping directly from the

inside of the container through the dip tube without pushing the product through the dip tube. By contrast, when the pressurized container does not comprise any dip tube, the undesired direction would be when the container is not inverted, i.e. the container is held upright. This substantially upright position leads to the escape of gaseous propellant from the inside of the container, because the product is not positioned between the discharging opening and the propellant. In both cases this leads to the escape of propellant from the inside of the container without any corresponding expulsion of product, resulting in the corresponding drawbacks as discussed before.

It is well known in the industry making pressurized containers that there is a need to provide the pressurized containers with a blocking mechanism which prevents the opening of the pressurized container when the pressurized container is in an undesired orientation. WO-91/03 408 and WO-95/06 606 describe blocking mechanisms, e.g. in form of a ball, located inside the pressurized container so as to block the discharging opening of the pressurized container when the pressurized container is in an undesired orientation. The blocking mechanism is thereby in direct contact with the product and the propellant during the discharging flow when the valve of the pressurized container is opened.

It has been found that the blocking mechanism positioned in this way in the discharging flow only works for low discharging rates of about 2 grams of product per second as the maximum limit. Indeed, the discharging rate has to be low enough such that the blocking means, e.g. the ball, is not dragged in the product and/or propellant flow. Otherwise the blocking means may be pushed by the discharging product and/or propellant into the blocking position of the valve even when the valve is oriented in the correct position. Therefore, it would be preferable to have a blocking mechanism separated from the discharging flow of the product and/or the propellant.

A blocking mechanism which is separated from the discharging flow of the product and/or of the propellant is, for example, described in US-3 186 605. This patent describes a valve comprising a blocking mechanism along a side of a valve stem. The blocking means comprises a circular transverse wall member, a circular plate and a non-compressible ball. The transverse wall member and the circular plate are rigidly connected to each other. The non-compressible ball is placed between the transverse wall member and the circular plate. The circular plate is smaller in diameter than the transverse wall member. To open the valve, the transverse wall member has to slide axially within the valve chamber towards a transverse shelf wall. The valve is free to be opened when the ball remains within the diameter of the circular plate. The valve is blocked when the ball rolls away from the circular plate onto the transverse shelf wall, since the transverse wall member is now prevented by the non-compressible ball from sliding towards the transverse shelf wall.

However this valve is quite bulky, since the overall diameter of the valve is increased by the transverse wall member and the valve chamber with respect to standard valves for standard pressurized containers. Furthermore, the part of the valve comprising the blocking mechanism is located on one side of the valve stem. Consequently, the container needs to have a wider opening to allow the insertion of this valve into the container with respect to usual valves, i.e. the containers in which to insert this valve of '605 have to be specially adapted and made. This increases also the manufacturing costs of a container with this kind of valve.

Another type of blocking mechanism is described in WO-89/10881, FR-A-2 637 870 and EP-A-0 526 298. The blocking mechanism is now located within the nozzle outside the pressurized container. It has been found that having the blocking mechanism in the nozzle limits the form and the dimension of the nozzle itself. Indeed, the nozzle has to be constructed in such a manner that it allows the functioning of the blocking mechanism. Furthermore, it has been found that such a specific nozzle comprising the blocking means has an increased cost with respect to usual nozzles available on the market. This means that when the blocking mechanism is not part of the valve, only specific, usually not cost effective nozzles can be used.

Therefore, it is an object of the present invention to provide a valve comprising a blocking mechanism, the blocking mechanism preventing the opening of the valve when the discharging opening of the valve is in an undesired orientation, being separated from the discharging flow of the discharging product and/or propellant from inside the pressurized container when the valve is applied to a pressurized container and is in the open position, allowing the use of any cost effective nozzle available on the market and having dimensions which allow the application of the valve to conventional containers.

#### Summary of the Invention

The present invention is a valve comprising a stem, a housing and a blocking means. The stem is movable within the housing to allow the opening and the closing of the valve. The stem comprises a discharging opening connected to a discharging channel. The discharging channel is located on one end of the stem. The housing comprises an orifice. The blocking means prevents the opening of the valve when the discharging channel is in an undesired orientation. The blocking means is separated from the discharging opening. The blocking means is located at the other end of the stem opposed to the discharging channel.

#### Brief description of the drawings

Figure 1a is a cross sectional view of an embodiment of a valve according to the present invention adapted to be applied to the top of a container, and is

shown as it would be when the container is in its upright position. Figure 1b is the same cross sectional view of the valve of Figure 1a when the valve is inverted, i.e. turned upside down. Figure 1c to 1e are alternative executions of the embodiment of Figure 1a. Figure 1f is a cross sectional view of another embodiment of a valve according to the present invention equivalent to the valve shown in Figure 1a when the container is in its upright position.

Figure 2a is a schematic cross sectional partial view of another embodiment of a valve according to the present invention adapted to be applied to the top of a container, and is shown as it would be when the container is in its upright position. Figure 2b is the same schematic cross sectional partial view of the valve of Figure 2a when the valve is inverted, i.e. turned upside down.

Figure 3a is a cross sectional view of yet another embodiment of a valve according to the present invention arranged and disposed as in the embodiments of Figure 1. Figure 3b is a cross sectional view of the valve of Figure 3a when the valve is inverted, i.e. turned upside down. Figure 3c is a perspective view of part of the valve of Figures 3a and 3b.

Figure 4a is a schematic cross sectional partial view of another embodiment of a valve according to the present invention adapted to be applied to the top of a container, and is shown as it would be when the container is in its upright position. Figure 4b is the same schematic cross sectional partial view of the valve of Figure 4a when the valve is inverted, i.e. turned upside down.

Figure 5a is a schematic cross sectional partial view of another embodiment of a valve according to the present invention adapted to be applied to the top of a container, and is shown as it would be when the container is in its upright position. Figure 5b is the same schematic cross sectional partial view of the valve of Figure 5a when the valve is inverted, i.e. turned upside down.

Figure 6a is a schematic cross sectional partial view of another embodiment of a valve according to the present invention adapted to be applied to the top of a container, and is shown as it would be when the container is in its upright position. Figure 6b is the same schematic cross sectional partial view of the valve of Figure 6a when the valve is inverted, i.e. turned upside down.

Figure 7a is a schematic cross sectional partial view of another embodiment of a valve according to the present invention adapted to be applied to the top of a container, and is shown as it would be when the container is in its upright position. Figure 7b is the same schematic cross sectional partial view of the valve of Figure 7a when the valve is inverted, i.e. turned upside down.

Figure 8a is a schematic cross sectional partial view of another embodiment of a valve according to the present invention adapted to be applied to the top of a

container, and is shown as it would be when the container is in its upright position. Figure 8b is the same schematic cross sectional partial view of the valve of Figure 8a when the valve is inverted, i.e. turned upside down.

Figures 9a and 9b are respectively schematic cross sectional partial views of other embodiments of a valve according to the present invention adapted to be applied to the top of a container, and is shown as it would be when the container is in its upright position.

Figures 10a and 10b are cross sectional views of embodiments of a valve according to the present invention adapted to be applied to the top of a container, and is shown as it would be when the container is in its upright position.

#### Detailed Description of the Invention

An embodiment of a valve (10) according to the present invention is shown in Figure 1a. The valve comprises a stem (11) surrounded by a housing (12). The housing can be made of a single piece or made of two parts which are attached to each other. In both cases the housing allows an easy insertion of the stem and of other parts of the valve into the housing. The housing may comprise as a second part a top wall (17), as shown in Figures 1a to 1d, or a top wall together with part of the side wall (13) of the housing (12), as shown in Figure 1e. The top wall (17) may be a gasket sealing the interior of the housing from the exterior. The housing comprises an orifice (14') connecting the interior of the housing with the interior of a container, when the valve is applied to the top of the container.

The valve further comprises a discharging opening (14), a discharging channel (15) and a blocking means (20). The discharging channel has an open end (15'). The valve is suitable to be applied to a container. The valve is applied to a container in such a manner that the orifice (14') of the housing (12) is placed inside the container, whereas the open end (15') of the discharging channel (15) is outside the container. As hereinafter referred to, "upright position of the valve" is the position of the valve where the open end (15') of the discharging channel is upwardly directed as shown, for example, in Figure 1a.

The valve has an open position and a closed position. The stem (11) is movable over a limited axial distance within the housing (12) between the open and the closed position of the valve. The closed position of the valve prevents any substantial escape of product and/or propellant from a filled container when the valve is applied to the filled container. In the present embodiment the closed position of the valve is achieved when the discharging opening (14) is not in direct fluid communication with the orifice (14') in the housing (12). Indeed, the valve is constructed so that, in the closed position, the discharging opening (14) is located within or above the thickness of the top wall (17) of the housing, i.e. the discharging opening (14) is not in connec-

tion with the inside of the housing. In this closed position of the valve, the product and/or the propellant is prevented from exiting the container when the valve is applied to a filled container.

The open position of the valve allows the discharge of the product and/or of the propellant from inside the container when the valve (10) is applied to a filled container. The valve is in the open position in the present embodiment when the discharging opening (14) is moved to below the underside of the top wall (17) inside the housing (12). The valve is in the open position when an external pressure is applied onto the valve. Specifically, the end part of the stem (11) comprising the open end (15') of the discharging channel (15) is subject to external pressure for the opening of the valve.

Preferably, the valve further comprises a spring (18). The spring is placed inside the housing (12) around the stem (11). Preferably, the spring is maintained under a certain compression such that the stem (11) of the valve is pushed in the closed position to ensure a tight closing of the valve. The spring is put under an increased compression when the valve is in the open position. Indeed, the open position of the valve is reached when the stem is pushed partially downwards along the axis (100) until the discharging opening (14) is inside the housing (12), whereby the spring is further compressed in this open position of the valve. Consequently, the spring automatically pushes the valve back into the closed position once the external force needed for the open position of the valve is released. The spring is preferably placed between annular shoulders (19) and (19'). The annular shoulder (19) is located on the outermost surface of the stem and the annular shoulder (19') on the innermost surface of the housing, as shown in Figure 1a. Preferably, the distance between the wings is such to keep the spring under compression also when the valve is in the closed position.

The discharging opening (14) in the stem (11) is directly connected to the discharging channel (15). The discharging channel leads towards the outside of the container when the valve is applied to a container. The discharging opening (14) is located on the outermost surface of the stem (11). The discharging channel is located on one end of the stem (11). Preferably, the dispensing opening (14) faces the orifice (14') in the housing (12) when the valve is in the open position. In this manner, the distance between the discharging opening (14) and the orifice (14') is minimized. Indeed, when the valve is applied to a filled container, the content of the container exits the container by passing first through the orifice (14') and then through the discharging opening (14) and discharging channel (15). The orifice (14') in the housing may be connected with a dip tube to the inside of the container.

The valve according to the present invention further comprises blocking means (20). The blocking means prevents the opening of the valve when the discharging channel (15) is in an undesired orientation. The undesired orientation of the discharging channel is whenever

the propellant is able to exit through the discharging opening (14) without being obliged to pass through the product, when the valve is applied to a filled pressurized container. This may happen as already described previously in an example with or without the dip tube. The blocking means of the valve according to the present invention is separated from the discharging opening (14). Thereby, the blocking means is not in direct fluid communication with the discharging flow of the discharging product and/or propellant from inside the pressurized container when the valve is applied to a pressurized container.

Indeed, the blocking valve is located in the embodiment of Figure 1 under separation means (30) between the end part (23) of the stem (11) and the end wall (24) of the housing (12). The separation means is such that the blocking means can not be dragged into the discharging flow of the product and/or of the propellant when the valve is in the open position. In practice, the separation means separates the stem in two part: one part (110) of the stem comprising the discharging opening (14) and discharging channel (15), the other part (120) comprising the blocking means. Thereby the part (120) of the stem is separated from part (110) such that the blocking means is prevented from being dragged into the discharging flow of the product and/or of the propellant when the valve is in the open position.

The separation means (30) may be an interrupted wall. An "interrupted wall" is herewith intended that the interruption in the wall allows the equalization of the pressure between parts (120) and (110) of the stem. The equalization of the pressure between part (120) and (110) of the stem can be achieved also by at least an orifice positioned on the parts of the walls of the housing located in part (120) of the stem, like the end wall (24). Consequently, also product and/or propellant may be allowed to pass into part (120) of the stem. However, the interrupted wall prevents that the blocking means comes into the discharging flow when the valve is in the open position. In this manner, a higher discharging rate of the product and/or of the propellant through the valve is allowed. In practice, the valve according to the present invention is not limited by any specific discharging rate, since the blocking means of the present valve is intended to block the movement of the valve stem when the valve is correctly oriented and the valve is in the open position. This was not always the case in the prior art as discussed above.

Preferably, the separation means (30) located between part (120) and part (110) of the stem is a seal completely isolating part (120) from part (110), i.e. the seal is preferably a continuous wall without interruption. Consequently, the blocking means is completely isolated from the discharging opening (14) and from the product and/or propellant. It has further been found that the viscosity of the product may adversely affect the functioning of the blocking mechanism. Indeed, part of the product may remain stuck around the blocking mechanism which facilitates a sticking of the blocking

mechanism on part of the valve. In this case, it may happen that the blocking mechanism blocks the valve even if the pressurized container is oriented in the correct way. It may also happen that the blocking means is slow to get to the blocking position from the non-blocking position, and vice versa the blocking means may be slow to return from the non-blocking position back to the blocking position. Consequently, the blocking means may still allow discharge through the valve when the position of the valve is already such that it should already prevent further discharge, and vice versa. Furthermore, the blocking means is also protected from corrosion when the separation is provided by a seal. The corrosion may be due to certain product and/or propellant characteristics, like the pH. Therefore, the blocking means completely isolated by the seal from the discharging opening (14) and from the product and/or propellant is a preferred execution of the valve according to the present invention.

The seal can be achieved with different sealing techniques. A possibility is the friction fit (Fig. 1a - 1e, 30a) in which the seal elastically presses against the outermost surface of the stem (11), as shown in Figure 1a. The pressing of the seal against the stem ensures that the product and/or the propellant is substantially prevented to enter into part (120) of the stem. Another possibility is given by an O-ring (Fig. 10a, 60) located around the stem and pressing against the innermost surface of the housing (12) isolating part (120) from part (110) of the stem, as shown in Figure 10a. A further possibility is a gasket (Fig. 10b, 70) located between the stem and the innermost surface of the housing again able to achieve an isolation of part (120) from part (110), as shown in Figure 10b. Preferably, when the seal is an O-ring or a gasket the housing (12) is made of two parts (13) and (13') attached to each other as shown in Figures 10a and 10b. The two parts (13) and (13') are preferably clamped together.

Preferably, the spring (18) is also located in part (120) of the stem (11) under the seal (30). In this manner, the spring as well as the blocking means (20) is protected from the product and/or propellant coming into part (110) of the stem through the orifice (14'). As a preferred option the valve further comprises a supporting means (50) for the stem (11) as illustrated in Figures 1c and 1d. The supporting means improves the stability of the stem within the housing when the valve is moved from the closed to the open position. Indeed, the stem is therefore supported at different points along the length of the stem: at the seal and at the supporting means. Another support for the stem may be located between the spring (18) and the blocking means (20) such to have three supporting points for the stem.

The blocking means (20) is located at the other end of the stem (11) with respect to the end of the stem comprising the discharging channel (15) and around the axis (100) of the stem. The blocking means is further located between the stem and the end wall (24) of the housing. Consequently, the blocking means does not

substantially further increase the radial or lateral dimension of the valve, since the blocking means is substantially within the thickness of the stem. Therefore, the valve with the blocking means according to the present invention does not need an enlarged opening in the container when the valve is applied to a container. In practice, the valve according to the present invention has substantially the same dimensions as valves without any blocking means, i.e. the container on which to apply the valve has not to be specially made for the valve according to the present invention.

In the embodiment of Figure 1a, the blocking means (20) comprises a movable, non-compressible barrier (21), like a non-compressible ball (21), and a recess (22) able to contain at least partially the movable, non-compressible barrier. The movable, non-compressible barrier (21) is located between the end part (23) of the stem (11) and the end wall (24) of the housing (12). The recess in Figure 1a is located in the end part (23) of the stem (11). However, as will be seen in an alternative embodiment of the valve according to the present invention, the recess may be also located in the end wall (24) of the housing (12). The recess (22) is of corresponding dimension to the ball such that the ball can enter at least partially into the recess. The recess may have a cylindrical shape, as shown in Figures 1a to 1e, or conical, as shown in Figure 1f. It has been found that the conical shaped recess as shown in Figure 1f allows a quicker entrance of the movable, non-compressible barrier (21) into the recess.

Preferably, the end wall (24) of the housing is inclined such that the movable, non-compressible barrier tends to be removed from the recess by the action of gravity when the valve is in the upright position as shown in Figure 1a. In this position the stem is prevented from moving towards the end wall (24) of the housing, since the ball remains between the stem and the end wall of the housing. However, when the valve is inverted, as shown in Figure 1b, the ball tends to fall at least partially into the recess. The ball being at least partially in the recess is sufficient to allow the stem to be moved towards the end wall opening the valve.

Consequently, the valve with the blocking means described in Figures 1a and 1b prevents the opening of the valve when the valve is in its upright position as shown in Figure 1a. The inclined end wall (24) of the housing (12) may preferably have a conical shape with the vertex (25) pointing towards the interior of the recess (22) as shown in Figure 1a. Alternatively, the end part (23) of the stem (11) may be inclined with the angle  $\alpha$ . Preferably, both, the end part (23) of the stem and the end wall (24) of the housing, may be inclined with the same angle  $\alpha$ . The angle  $\alpha$  is measured between the horizontal plane (26) and the plane parallel to the end wall (24) oriented towards the vertex, or between the horizontal plane (26) and the plane parallel to the end part (23) of the stem oriented towards the recess (22). The angle  $\alpha$  determines the angle at which the ball (21) is more likely to fall into the recess (22). Indeed, by

increasing this angle  $\alpha$ , the ball falls into the recess when the valve is inverted to a lesser extent than if the angle  $\alpha$  would be smaller.

Consequently, by choosing the angle  $\alpha$  the blocking means can be selected to let the ball fall into the recess when the valve is completely turned upside down (at 180 deg from the upright position) or already before the complete upside down position at 180 deg. Preferably, the blocking means of Figures 1a and 1b have an angle  $\alpha$  such to allow the opening of the valve between about 90° and about 180° from the upright position, more preferably between about 110° and about 180°, most preferably between about 135° and about 180°.

As a further preferred option, the end wall (24) of the housing may further comprise edges (31) or grooves (32), as shown in Figures 9a and 9b. These ledges or grooves placed on the surface of the end wall directly facing the stem reduce the probability that the incompressible barrier falls into the recess by chance without having properly inverted the valve. In practice these ledges or grooves further increase the angle at which the valve has to be inverted before allowing the valve to open.

Figures 2a and 2b show in a partial view another embodiment of the valve according to the present invention in which the valve opens when the valve is substantially in the upright position. Indeed, in Figure 2a the inclined end wall (24) is an inverted cone with respect to the end wall of Figure 1a. Consequently, the ball (21) rolls always towards the concave part of the vertex (25) by the action of gravity when the valve is in the upright position. In this position the stem is able to be moved towards the end wall (24) of the housing, thereby opening the valve, since the ball enters the recess (22). However, if the valve is turned away from the upright position, the ball, under the action of gravity rolls between the stem and the end wall away from the recess. Consequently, the stem is prevented to be moved towards the end wall and the valve stays in the closed position.

Figures 3a and 3b show an alternative embodiment of the valve according to the present invention. The end part (23) of the stem comprising the recess (22) is sufficiently flexible to narrow the access to the inside of the recess. The narrowing to the access to the recess can be achieved by converging the side wall (27) of the housing towards the end wall (24) of the housing. In this manner the space in which the stem (11) is housed is narrowed towards the end wall (24) of the housing. Preferably, the narrowing of the side wall is achieved by having the side wall (27) of slightly conical shape whereby the dimension of the hollow body between the side wall (27) diminishes towards the end wall (24) of the housing, as shown in Figure 3a. As a preferred option, the end wall (24) of the housing comprises a supporting wall (28) on which the non-compressible ball rests when the valve is in its upright position, as shown in Figure 3a.

The dimension of the ball is such to prevent the end part (23) of the stem to be further moved towards the

base of the housing, if the ball is not completely within the recess before the stem is moved, i.e. the valve is blocked in the closed position. Indeed, the valve has first to be inverted such that the ball enters into the recess and then the stem is free to move further towards the end wall (24) of the housing to allow the opening of the valve, as shown in Figure 3b. Preferably, the end part (23) of the stem is made of flexible fingers (23a) interrupted by slots (23b) surrounding the recess, as shown in Figure 3c. This configuration of the end part (23) of the stem improves the flexibility of the end part (23) itself. Thereby this supporting wall does not impede the movement of the stem once the ball is entered into the recess.

Figures 4 to 6 show alternative embodiments of the non-compressible barrier (21) for a blocking means according to the present invention. Instead of a spherical, non-compressible ball, a pin having an oval cross section can also be foreseen as a non-compressible barrier, as shown in Figure 4a. The recess (22) is shaped and dimensioned to correspond to the shape of the non-compressible barrier. Figure 4b shows the pin located in the recess when the valve is turned in the inverted position with respect to the upright position of Figure 4a.

Figure 5a shows another non-compressible barrier (21) pivotally attached to the end wall (24) of the housing (12) of a valve (10) partially shown. Preferably, the non-compressible barrier is a pin as described in Figures 4a and 4b. One end of the non-compressible barrier is pivotally attached to the end wall (24) such that the non-compressible barrier is directed by the action of the gravity force into a position which prevents the opening of the valve when the valve is in its upright position, as shown in Figure 5a. In this case, the pivotally attached pin is directed away from the recess (22). Instead, when the valve is inverted completely from the upright position as shown in Figure 5b, the non-compressible barrier is directed still by the action of the gravity force towards the interior of the recess. In this position the stem of the valve can be moved towards the end wall (24) of the housing, since the non-compressible barrier enters into the recess without impeding the movement of the stem.

Figures 6a and 6b show a similar a blocking means as described before in Figures 5a and 5b, however which allows the opening of the valve only in the upright position as shown in Figure 6a. Indeed, the non-compressible barrier or pin is pivotally attached at one end on the end part (23) of the stem (11) and the recess (22) is located in the end wall (24) of the housing. Consequently, the pin enters the recess (22) when the valve is in its upright position, as shown in Figure 6a. Whereas, when the valve is inverted the pin is directed away from the recess by the action of the gravity force, as shown in Figure 6b, blocking the opening of the valve.

Other alternative non-compressible barriers can be achieved also by liquids which are not compressible. In Figure 7a the recess (22) in the end wall (24) of the

housing (12) is at least partially filled with a non-compressible liquid, like water. The end part (23) of the stem comprises a finger (29) having the corresponding dimension of the recess. The dimensions of the finger and of the recess are respectively dimensioned such to achieve a sealing between the finger and the recess. In this manner it is substantially prevented that the liquid in the recess escapes from the recess when the finger is inserted into the recess. Preferably, the finger further comprises a sealing element (40) to improve the sealing between the finger and the recess. Preferably, such a sealing element is an O-ring surrounding the finger.

This finger (29) cannot enter completely into the recess (24), since the liquid inside the recess is incompressible and cannot exit from the recess because of the sealing between the finger and the recess. Only when the valve is first inverted can the finger of the stem enter into the recess, allowing the opening of the valve. Indeed, as shown in Figure 7b, the liquid exits at least partially from the recess and the finger has enough space in the recess to allow the opening of the valve. As a preferred option, the end wall (24) of the housing may comprise more than one recess. Each recess is filled at least partially with an incompressible liquid and corresponding to each recess a finger (29) on the end part (23) of the stem has to be moved into the recess to allow the opening of the valve, as shown in Figures 8a and 8b. The blocking mechanism is identical to that one described for Figures 7a and 7b.

Preferably, the valve according to the present invention is used on a pressurized container. A pressurized container is usually obtained by filling the container with a product and a propellant. The container is hollow body which may be made from any material, preferably metal, plastics including polyethylene terephthalate (= PET), oriented polypropylene (= OPP), polyethylene (= PE) or polyamide and including mixtures, laminates or other combinations of these. The metal can may be made from tin plated steel or other metals such as aluminium. Preferably, the interior surface of the metal container is laminated with a plastic material or coated with a lacquer or with a varnish. The lacquer or varnish are such to protect the interior surface of the container from corrosion. The corrosion may lead to a weakening of the container and may also lead to a discoloration of the container's content. Preferred plastic materials for lamination and lacquers or varnishes for coating are epoxy phenolic, polyamide imide, organosol, PET, PP, PE or a combination thereof.

The pressure inside the container is mainly created by the propellant. The pressure inside the pressurized container is such that the product and the propellant is expelled through the discharging opening (14) and through the discharging channel (15) to the outside of the container once the valve is in the open position. The pressure inside the container is therefore higher than the external atmospheric pressure outside the container. The pressure inside the container is preferably at least 5 bar at 20°C, more preferably the inside pressure

is in the range between 8 bar and 10 bar at 20°C.

The propellant, as said before, helps to discharge the product from inside the container. The quantity of propellant contained in the container is such that substantially all the product can be expelled out of the container throughout the life of the pressurized container at the correct pressure. The quantity also depends from the type of propellant used. Suitable propellants known in the art are liquid and gaseous propellants. Preferred propellants are gaseous propellants for environmental friendliness. As herein referred to, the words "gaseous" and "non-liquifiable" are used interchangeably in regard to the propellant. Indeed, gaseous propellants or non-liquifiable propellants are propellants which are in a gaseous state of matter at room temperature (about 20°C) and at pressures up to 12 bar. Furthermore, it is preferred to use 'ozone-friendly' propellants such as compressed air, carbon dioxide, nitrogen and oxides thereof or mixtures thereof. Carbon dioxide is the more preferred gaseous propellant. Minor amounts of low molecular weight hydrocarbons, such as propane, butane, pentane, hexane, may optionally be included provided that flammability requirements are not exceeded. Various ways to pressurise the propellant gas are known in the art. For example the gas may be pressurised at the time of packing. The product may be physically separated from a compressed gas by a membrane such as rubber under tension. Alternatively a means for pressurising the gas subsequently by mechanical action may be provided (so-called "pump and spray" systems).

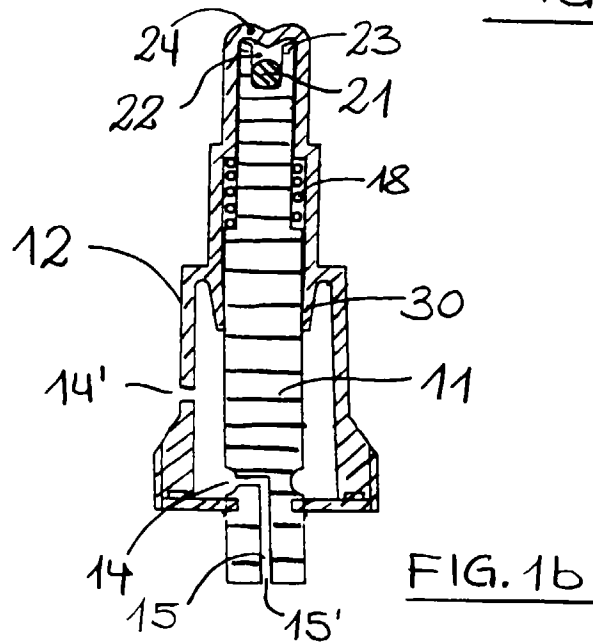
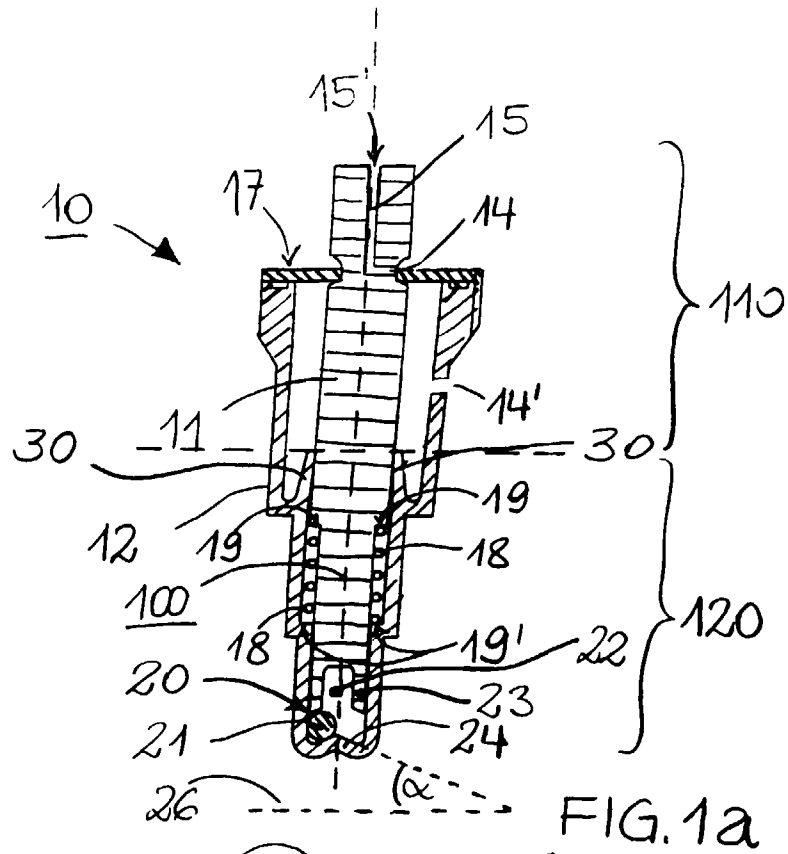
Any gaseous, liquid or foaming product can be discharged through the valve according to the present invention. Preferred are foaming products when discharged with gaseous propellant. The propellant expands to form many bubbles within the composition thereby creating the foam. Specific hard surface cleaners are examples of foaming products. Such a foaming product is disclosed, for example, in EP-A-546 828. A preferred foaming product according to the present invention is a foaming laundry cleaning detergent. A foaming laundry cleaning composition is disclosed in EP-A-677 577 and in the co-pending European Patent Application No. 95870084.1.

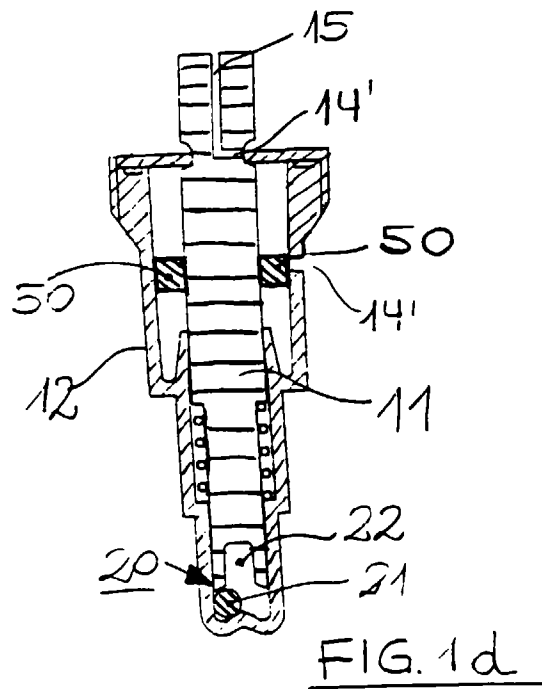
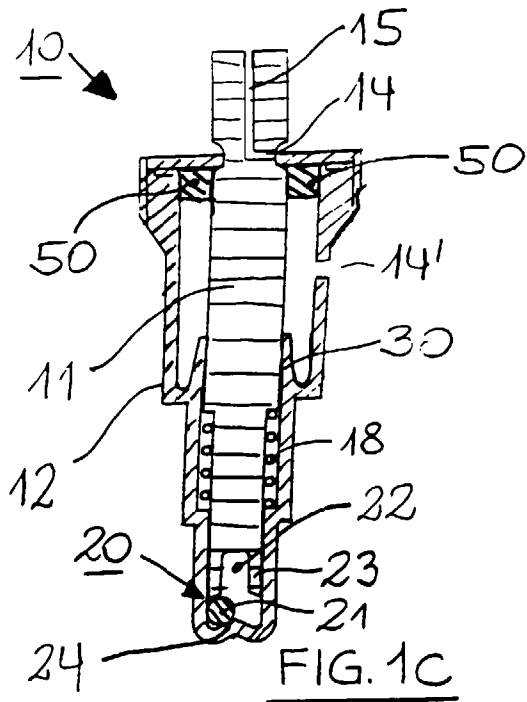
## Claims

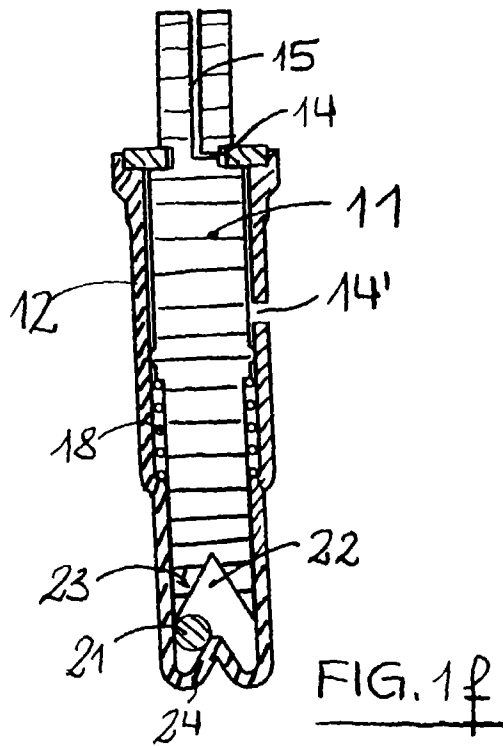
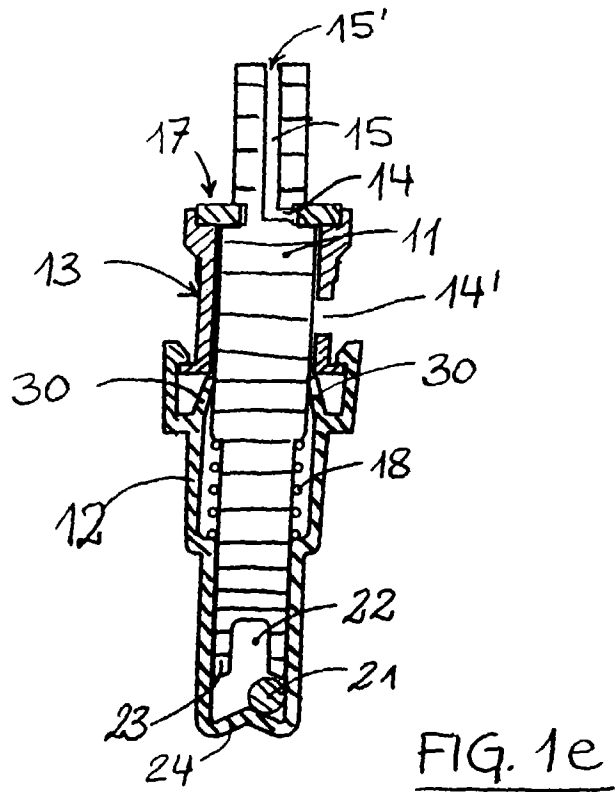
1. A valve (10) comprising a stem (11), a housing (12) and a blocking means (20), the stem (11) being movable within the housing (12) to allow the opening and the closing of the valve (10), the stem (11) comprising a discharging opening (14) connected to a discharging channel (15), the discharging channel (15) being located on one end of the stem (11), the housing comprising an orifice, the blocking means (20) preventing the opening of the valve (10) when the discharging channel (15) is in an undesired orientation, the blocking means being separated from the discharging opening (14),

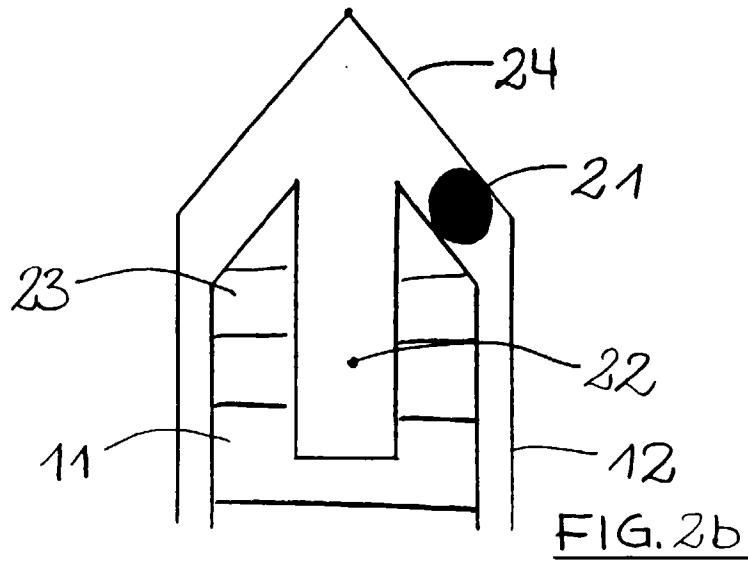
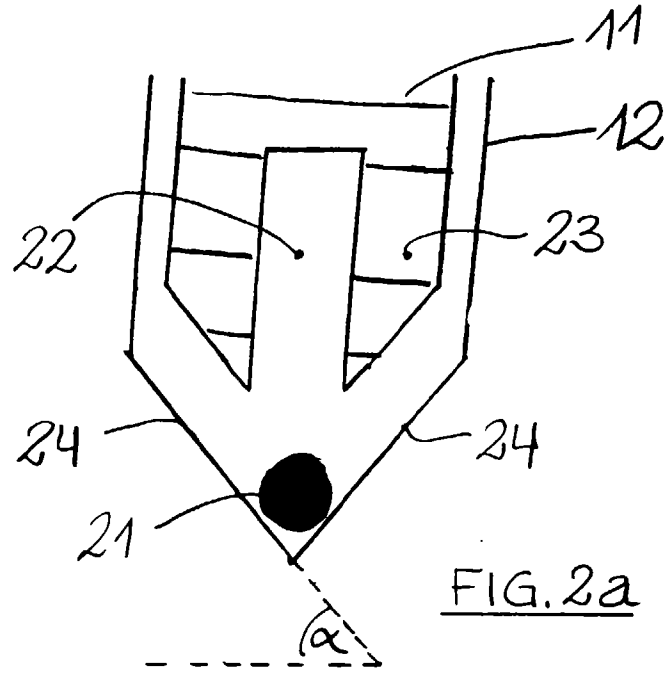
characterized in that the blocking means (20) is located at the other end of the stem (11) opposed to the discharging channel (15).

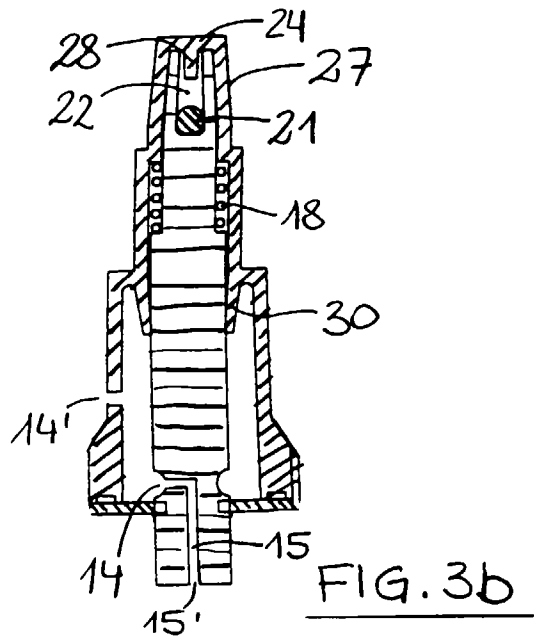
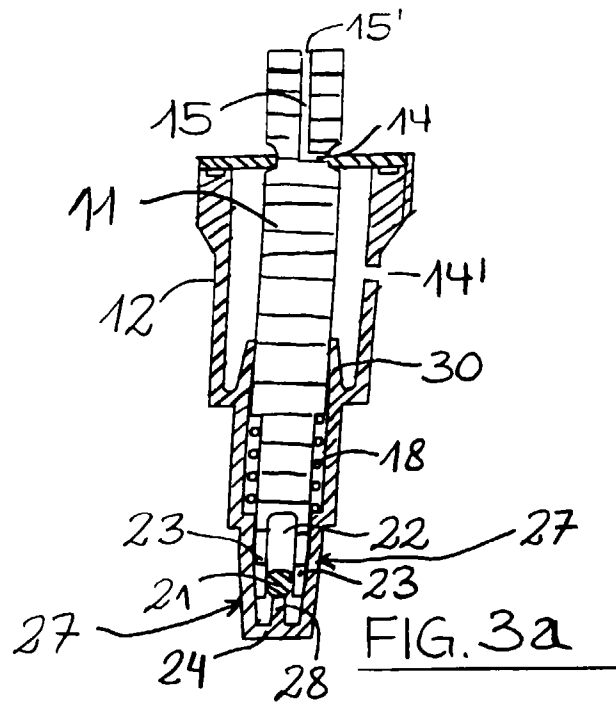
2. A valve according to claim 1 characterized in that the blocking means (20) comprises a movable non-compressible barrier (21) and a recess (22), the barrier being located between the end of the stem (11) opposed to the discharging channel and the end wall (24) of the housing (12).
3. A valve according to claim 2 characterized in that the recess (22) is located in the end part (23) of the stem (11) or in the end wall (24) of the housing (12).
4. A valve according to claim 3 characterized in that the end wall (24) of the housing (12) is inclined.
5. A valve according to claim 3 or 4 characterized in that the end part (23) of the stem (11) is inclined.
6. A valve according to any of claims 2 to 5 characterized in that the movable, non-compressible barrier (21) is a spherical ball or an oval pin.
7. A valve according to claim 3 characterized in that the movable, non-compressible barrier (21) is pivotally attached to the end part (23) of the stem (11) or in the end wall (24) of the housing (12).
8. A valve according to claims 2 to 5 characterized in that the movable non-compressible barrier (21) is a liquid.
9. A valve according to any of the preceding claims characterized in that the blocking means (20) is separated from the discharging opening (14) by an interrupted wall.
10. A valve according to claim 9 characterized in that the valve (10) further comprises a spring (18) separated from the discharging opening (14) by the interrupted wall.
11. A valve according to any of claims 1 to 8 characterized in that the blocking means (20) is completely isolated from the discharging opening (14) by a seal (30).
12. A valve according to claim 11 characterized in that the valve (10) further comprises a spring (18) which is completely isolated from the discharging opening (14) by the seal (30).

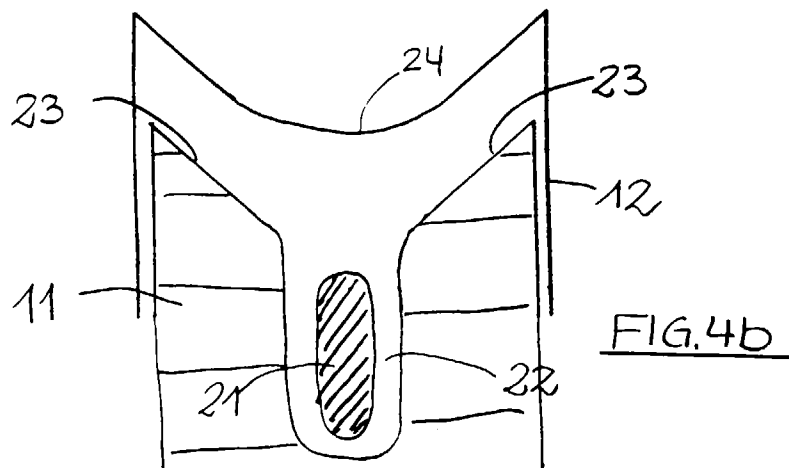
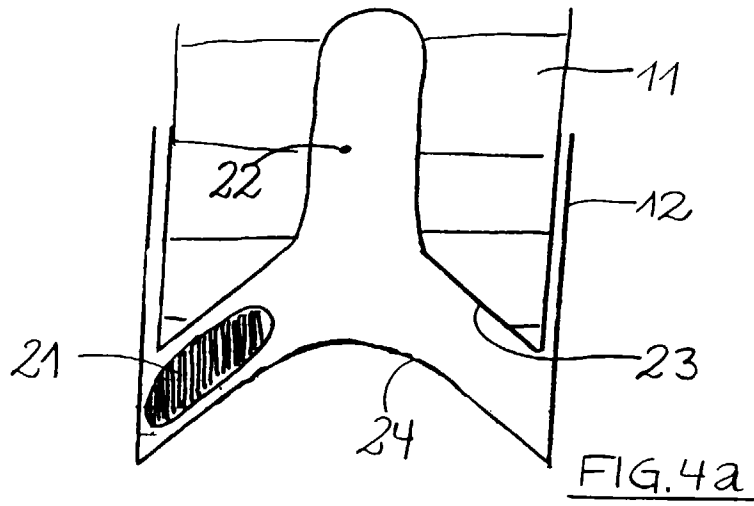
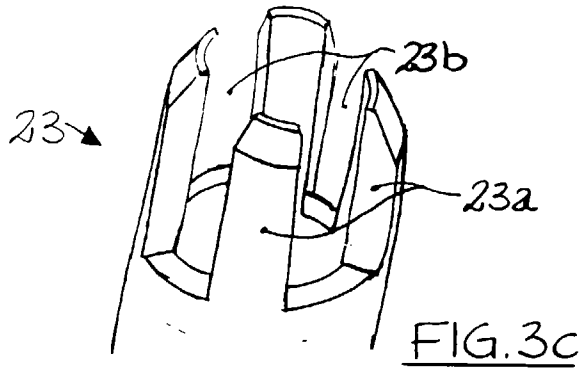


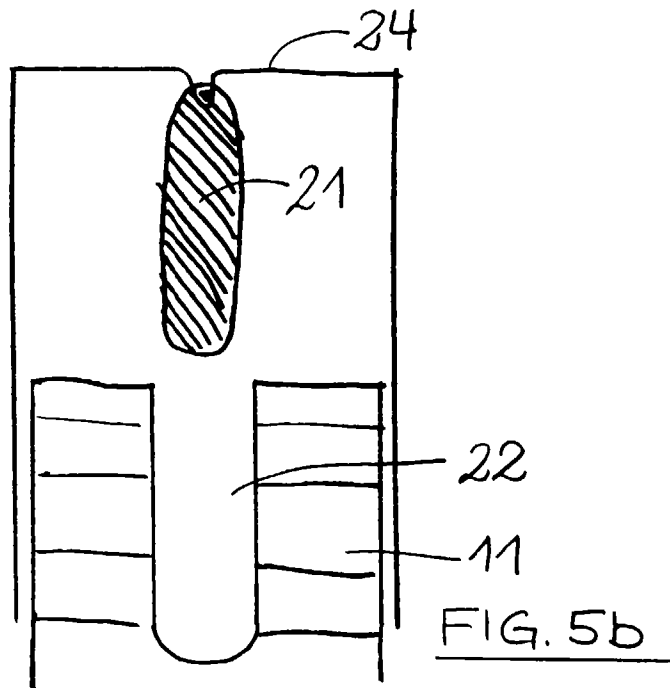
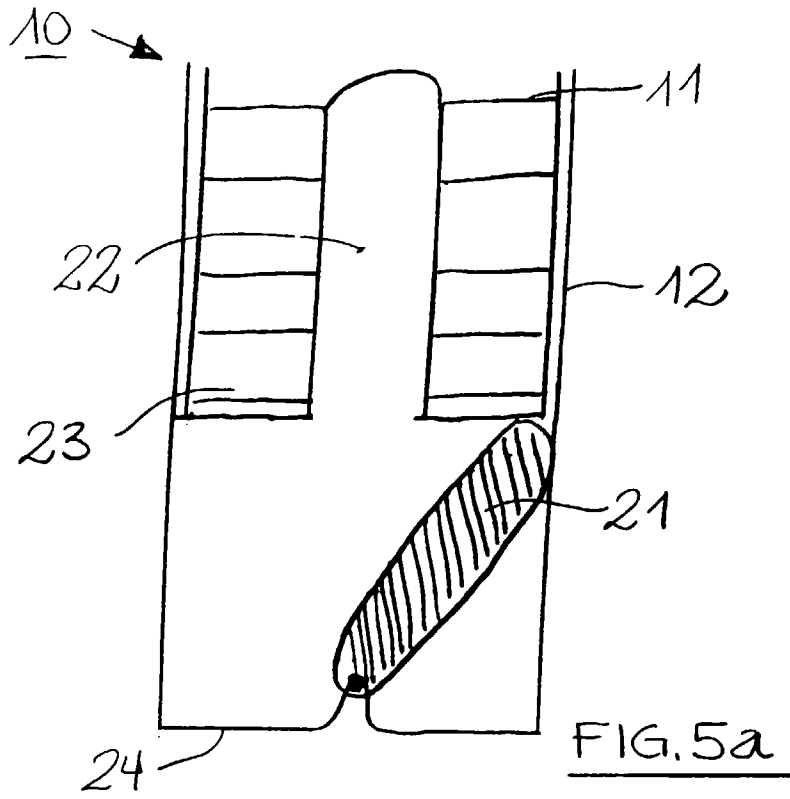


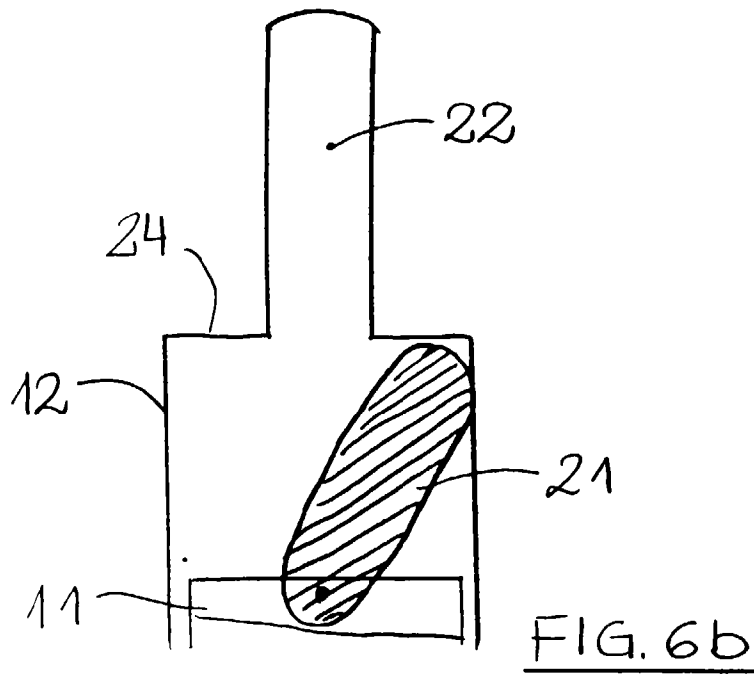
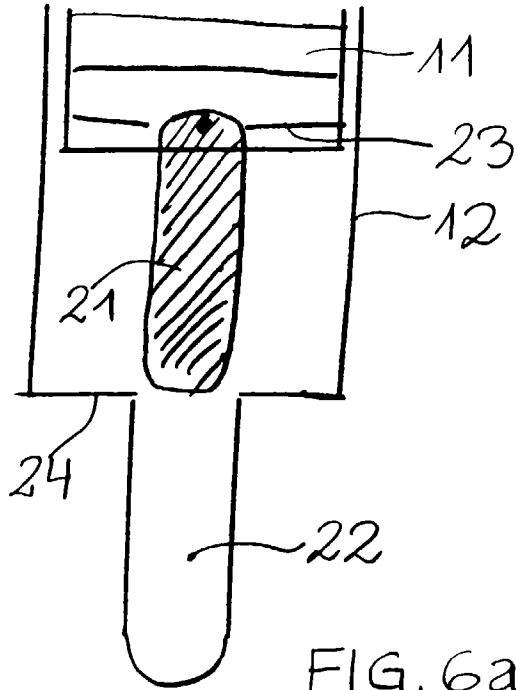


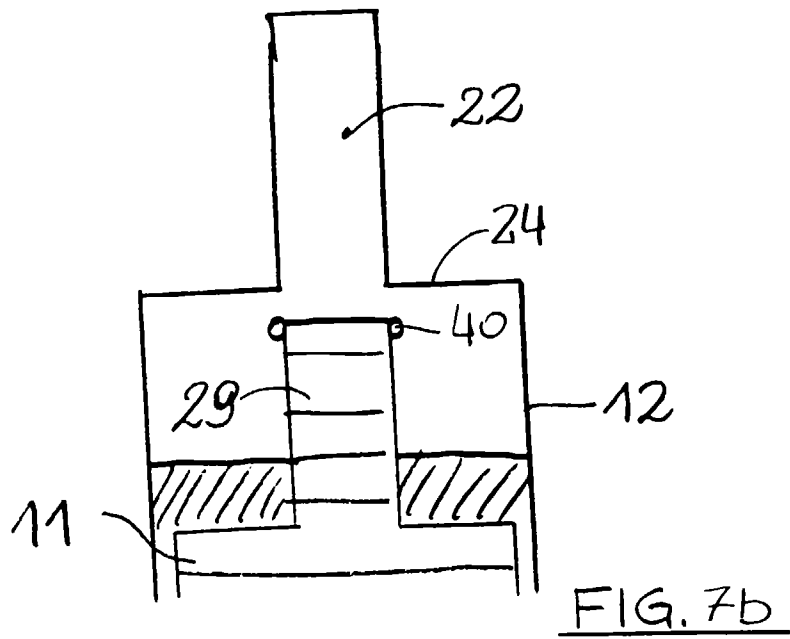
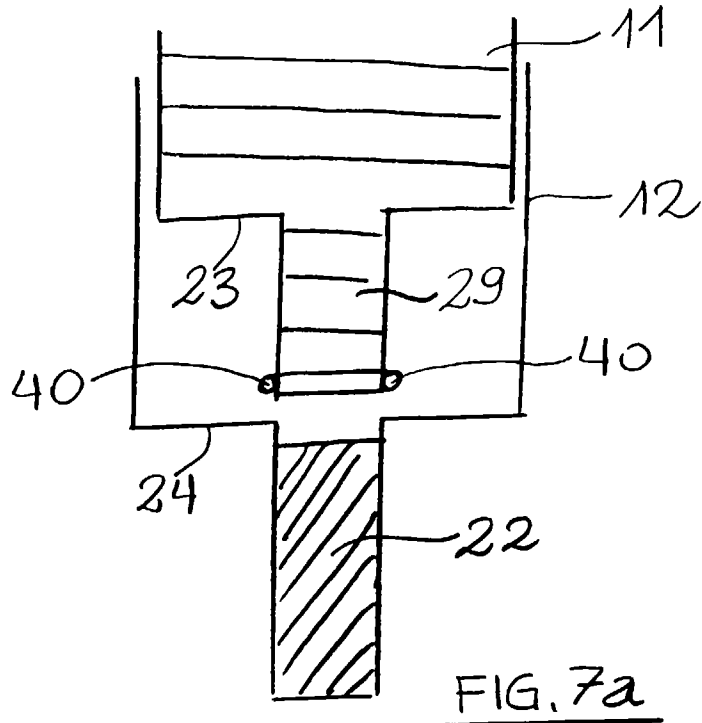












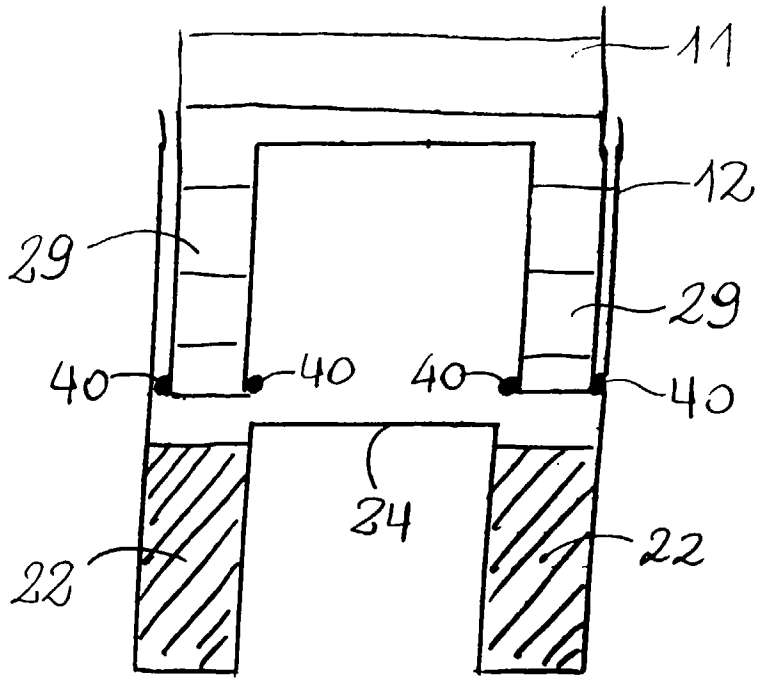


FIG. 8a

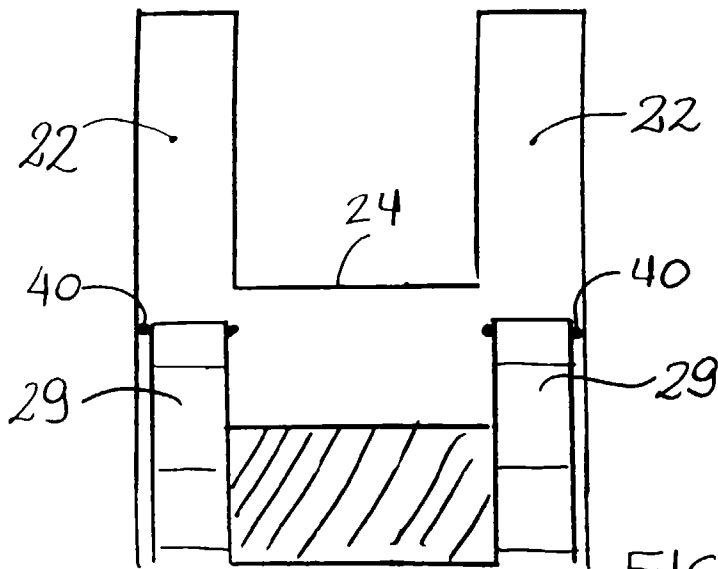
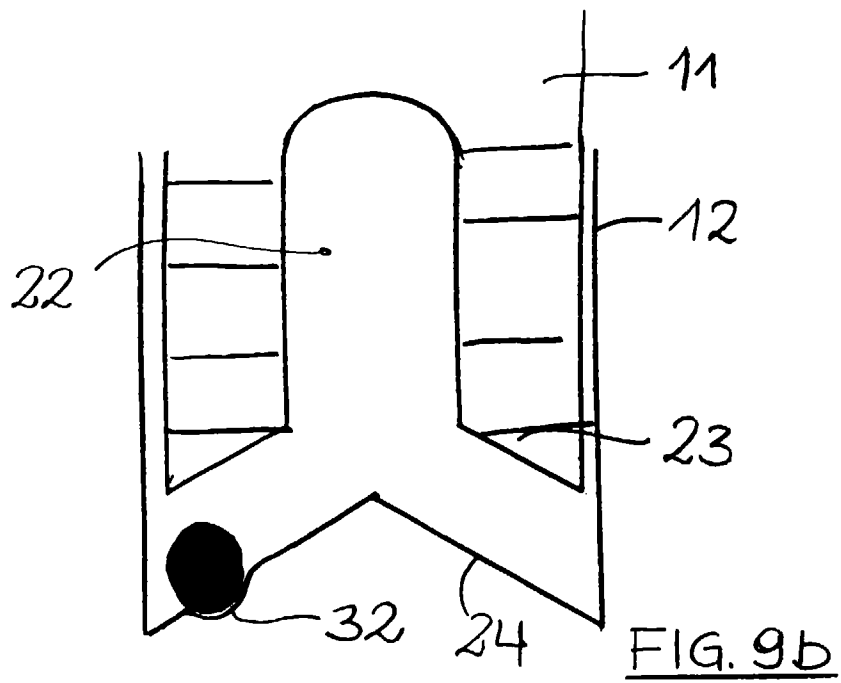
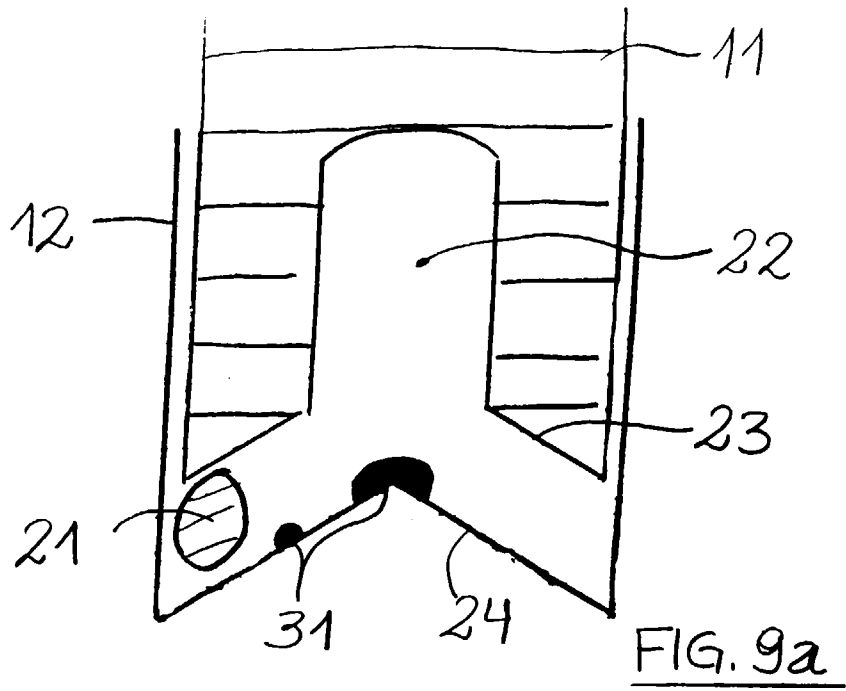


FIG. 8b



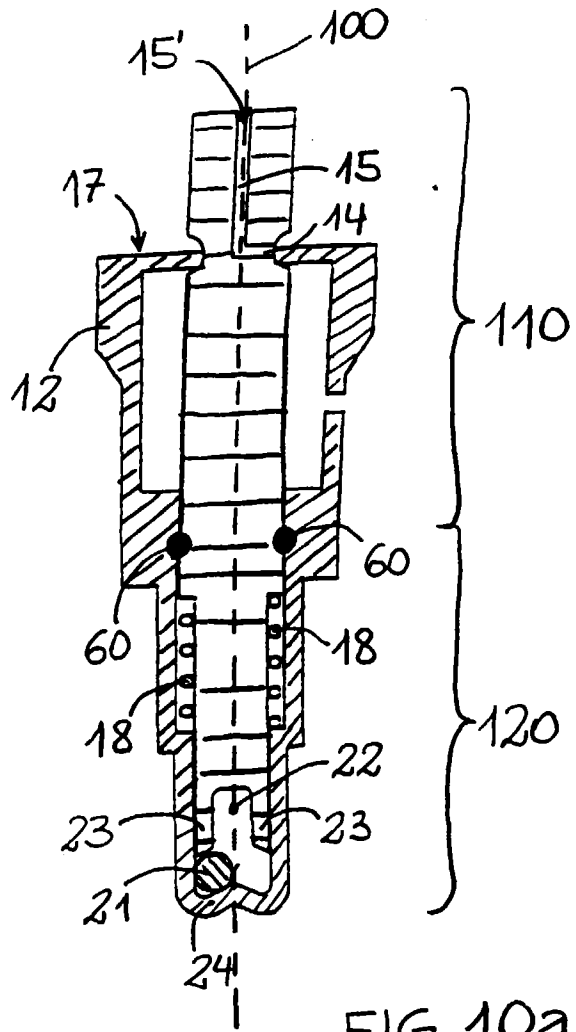


FIG. 10a

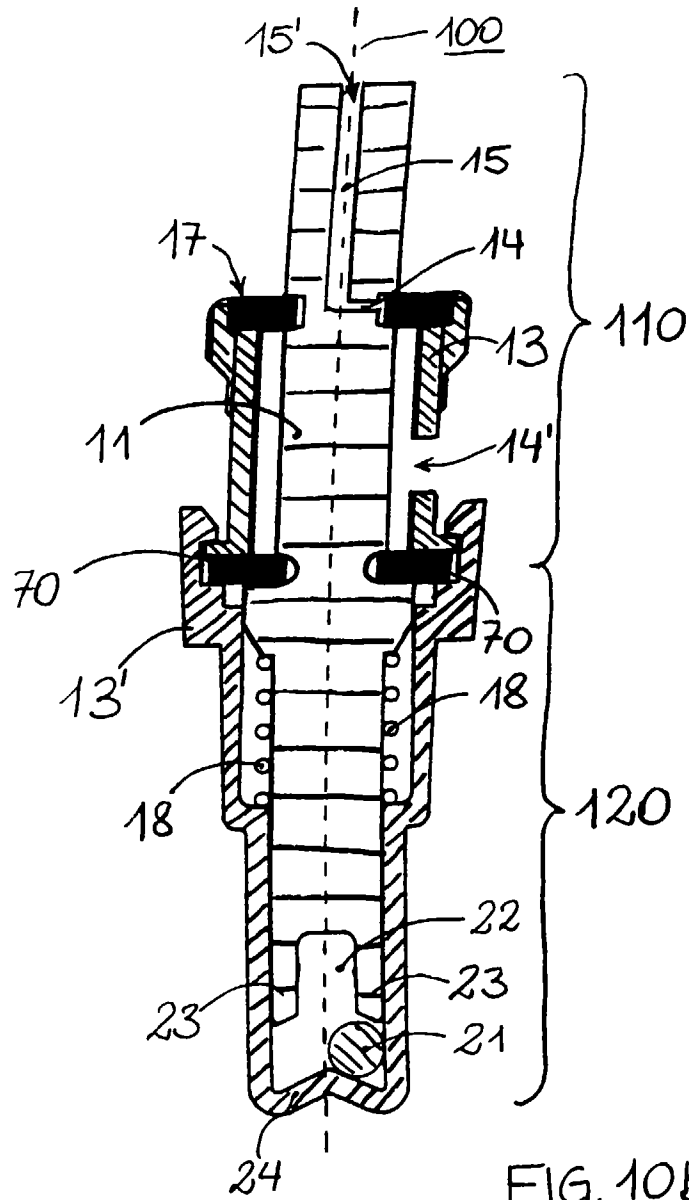


FIG. 10b



European Patent  
Office

## EUROPEAN SEARCH REPORT

Application Number  
EP 96 20 1604

DOCUMENTS CONSIDERED TO BE RELEVANT			
Category	Citation of document with indication, where appropriate, of relevant passages	Relevant to claim	CLASSIFICATION OF THE APPLICATION (Int.Cl.6)
X	FR-A-2 295 332 (AEROSOL INVENTIONS AND DEVELOPMENT)	1,9	B65D83/44 B65D83/56
Y	* page 2, line 33 - page 3, line 8; figures *	10	
X	---		
	PATENT ABSTRACTS OF JAPAN vol. 96, no. 002 & JP-A-08 048379 (SEIICHI KITABAYASHI;OTHERS: 01), 20 February 1996, * figure *	1-6	
Y	---	8	
Y	GB-A-854 047 (POTOCZKY) * page 5, line 12 - line 45; figures 6,7 *	8	
Y	---		
Y	US-A-3 900 139 (MYERS)	10	
A	* column 3, line 54 - line 65; figure 2 *	12	
A	---		
	PATENT ABSTRACTS OF JAPAN vol. 016, no. 030 (M-1203), 24 January 1992 & JP-A-03 240680 (SEIICHI KITABAYASHI;OTHERS: 01), 28 October 1991, * abstract; figures *	7	
	-----		
The present search report has been drawn up for all claims			
Place of search		Date of completion of the search	Examiner
THE HAGUE		6 November 1996	Bridault, A
CATEGORY OF CITED DOCUMENTS			
X : particularly relevant if taken alone		T : theory or principle underlying the invention	
Y : particularly relevant if combined with another document of the same category		E : earlier patent document, but published on, or after the filing date	
A : technological background		D : document cited in the application	
O : non-written disclosure		L : document cited for other reasons	
P : intermediate document		.....	
		& : member of the same patent family, corresponding document	