



(19)

Europäisches Patentamt

European Patent Office

Office européen des brevets



(11)

**EP 0 811 756 A3**

(12)

**EUROPEAN PATENT APPLICATION**

(88) Date of publication A3:  
18.03.1998 Bulletin 1998/12

(51) Int. Cl.<sup>6</sup>: **F01P 5/10**, F02B 67/06,  
F01P 11/04, F02F 7/00

(43) Date of publication A2:  
10.12.1997 Bulletin 1997/50

(21) Application number: **97114938.0**

(22) Date of filing: **28.10.1994**

(84) Designated Contracting States:  
**DE FR GB**

(30) Priority: **29.10.1993 JP 294118/93**

(62) Document number(s) of the earlier application(s) in  
accordance with Art. 76 EPC:  
**94117108.4 / 0 651 141**

(71) Applicant:  
**YAMAHA HATSUDOKI KABUSHIKI KAISHA**  
Iwata-shi Shizuoka-ken, 438 (JP)

(72) Inventor: **Saito, Tetushi**  
Iwata-shi, Shizuoka-ken, 438 (JP)

(74) Representative:  
**Grünecker, Kinkeldey,**  
**Stockmair & Schwanhäusser**  
**Anwaltssozietät**  
**Maximilianstrasse 58**  
**80538 München (DE)**

(54) **Four-cycle engine**

(57) The present invention relates to a four-cycle engine, specifically to a cooling arrangement thereof, said engine comprising a cylinder block (15) and a cylinder head (14), a chain drive (100) means for driving at least one camshaft (64,65) from a primary drive shaft (11) and a chain cover (16) extending along a side of the engine wherein in said chain cover (16) forms part of a case for the water pump (5) which, therefore, can be integrated smoothly into the engine allowing to drive the water pump (5) in common to the other auxiliary equipment and to avoid hoses or the like for cooling other components of the engine.

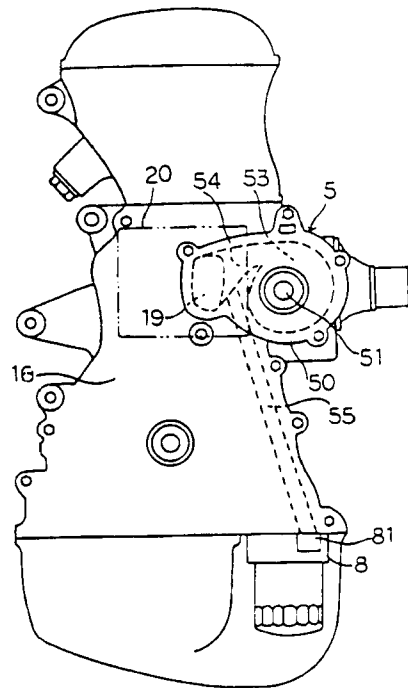

Fig. 8

**EP 0 811 756 A3**



European Patent  
Office

EUROPEAN SEARCH REPORT

Application Number  
EP 97 11 4938

DOCUMENTS CONSIDERED TO BE RELEVANT			
Category	Citation of document with indication, where appropriate, of relevant passages	Relevant to claim	CLASSIFICATION OF THE APPLICATION (Int.Cl.6)
A	US 2 852 009 A (TURLAY) * the whole document * ---	1	F01P5/10 F02B67/06 F01P11/04 F02F7/00
A	US 5 148 784 A (HIRAOKA) * abstract; figures * ---	1	
A	DE 960 326 C (SCHEITERLEIN) * the whole document * ---	1	
A	DE 933 902 C (BERTRAM) * figure * ---	1	
A	DE 42 11 896 A (MERCEDES-BENZ) * figures * -----	1	
The present search report has been drawn up for all claims			TECHNICAL FIELDS SEARCHED (Int.Cl.6)
			F01P F02F F02B F01M
Place of search		Date of completion of the search	Examiner
THE HAGUE		13 January 1998	Kooijman, F
CATEGORY OF CITED DOCUMENTS			
X : particularly relevant if taken alone Y : particularly relevant if combined with another document of the same category A : technological background O : non-written disclosure P : intermediate document		T : theory or principle underlying the invention E : earlier patent document, but published on, or after the filing date D : document cited in the application L : document cited for other reasons & : member of the same patent family, corresponding document	

EPO FORM 1503 03 82 (F04C01)