

(19)



Europäisches Patentamt
European Patent Office
Office européen des brevets



(11) EP 0 812 766 A1

(12) EUROPEAN PATENT APPLICATION

(43) Date of publication:
17.12.1997 Bulletin 1997/51

(51) Int. Cl.⁶: B65B 25/06, B65D 77/00,
B65D 85/76, B26D 3/18

(21) Application number: 96109614.6

(22) Date of filing: 14.06.1996

(84) Designated Contracting States:
AT BE CH DE DK ES FI FR GB GR IE IT LI LU MC
NL PT SE
Designated Extension States:
AL LT LV SI

(71) Applicant:
KRAFT JACOBS SUCHARD R & D, INC.
Rye Brook, New York 10573 (US)

(72) Inventors:
• Simbürger, Stephan
81375 München (DE)

• Wernecke, Klaus
83052 Bruckmühl/Götting (DE)
• Marder, Uwe
28865 Lilienthal (DE)

(74) Representative:
Weickmann, Heinrich, Dipl.-Ing. et al
Patentanwälte
H. Weickmann, Dr. K. Fincke
F.A. Weickmann, B. Huber
Dr. H. Liska, Dr. J. Prechtel, Dr. B. Böhm
Postfach 86 08 20
81635 München (DE)

(54) A food packaging unit, a method for manufacturing said food packaging unit and an apparatus for performing said method

(57) A packaging unit (40) for food stuff bodies and more particularly cubic cheese bodies (22) comprises a carrier tray (10) with a carrier surface (12) and side walls (14). A layer of food stuff bodies is obtained by pressing of a disc-shaped preproduct through a cutting grid. At least one of the said layer of cubic cheese bodies (22) is loaded on the carrier surface (12) and laterally secured by side walls (14). The cubic cheese bodies have a

height larger than the height of the side walls (14). A bag shaped film (32) covers the packaging unit (40) and encapsulates the tray (10) and cheese bodies (22). The said bag (32) is sealed and filled with protective gas and secures the cheese bodies (22) on the carrier surface (12) of the tray (10).

Fig. 3

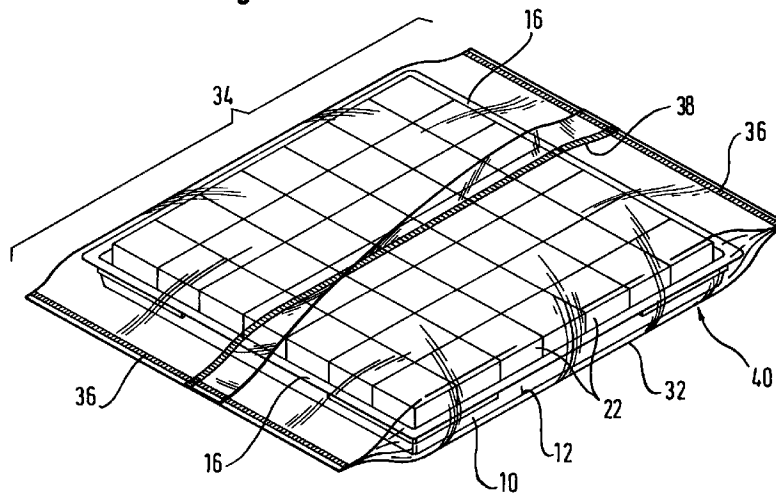

EP 0 812 766 A1

Description

This invention relates to a food packaging unit and more particularly to a cheese packaging unit.

The presentation of cheese in the shape of cubic bodies of about 10 mm edge length is well known. These cubic bodies are e. g. offered as snacks which are handled by tooth picks. Further, it is known to use cubic cheese bodies as additives for certain food preparations, e. g. spaghetti. The cheese bodies for the latter use have an edge length of about 5 to 10 mm. Usually, these cubic cheese bodies are prepared immediately before use without packaging problems.

It is an object of the present invention to provide cheese bodies and similar food stuff bodies for the above-mentioned fields and for similar fields of use such that they can easily be handled on the way from the industrial manufacturer to the final consumer and by the final consumer himself.

In view of this object a food packaging unit is proposed according to this invention, this food packaging unit comprising at least one carrier member having a carrier surface and a plurality of food product bodies and more particularly cheese bodies being positioned in at least one layer with their respective bottom faces on the carrier surface. The food stuff bodies are allowed to have body contact with each other by respective side faces. The food stuff or food product bodies have a body structure of sufficient stability for maintaining their respective shape during packing, shipping, distribution and use, substantially until the time of human consumption. The food stuff bodies have a surface structure preventing substantial coherence of mutually contacting side faces. The food product bodies are covered and secured with respect to the carrier surface by a covering film.

This food packaging unit allows the industrial production of the food product bodies in such a way that the food product bodies can be easily handled even if there is a long way from the food product manufacturer to the final consumer. The food product bodies, when coming in the hands of the final consumer, still are arranged in good order on the carrier member and thus have a considerable sales appeal. The food stuff bodies can easily be handled by party service organizations who want to offer them e. g. at a cocktail party. They can also easily be handled by a housewife who wants to use the cheese bodies e. g. as an additive to a spaghetti preparation. It is easily possible to remove the cheese bodies from the carrier member and to spread them over the respective food preparation. If all the food stuff bodies on the carrier are to be spread on the food preparation, this can easily be done by tilting the carrier member. If only a part of the food stuff bodies on the respective carrier member is to be used as an additive for a respective food preparation, one can remove the food stuff bodies, e. g. by a knife engaging one or several rows of food stuff bodies and shift these rows along the carrier surface to one of the edges of the carrier surface so that

they can fall from the possibly inclined carrier surface onto the respective food preparation.

The covering film may have several functions. One function is to secure the food stuff bodies on the carrier member during shipping and distribution. In view of this purpose, the covering film is preferably in intimate contact with at least the top faces of the food stuff bodies so that they are maintained in the vicinity of the carrier surface even when the carrier member is tilted or turned. A further function of the covering film is to protect the food stuff bodies against contamination. A still further purpose of the covering film may be to provide a cavity around the food stuff bodies which prevents fast exchange of the surrounding atmosphere and possibly even allows to maintain a protecting atmosphere for the food stuff bodies.

The covering film may be made of a large variety of usual materials like paper, plastic film, metal foil, or combinations thereof.

The food stuff bodies are preferably shaped with substantially planar top and bottom faces and further with side faces extending in a substantially orthogonal direction with respect to the carrier surface. Such an arrangement of faces is not only helpful for easy packing, but also helpful for easily manufacturing the food stuff bodies by cutting techniques.

The side faces of the food stuff bodies may be substantially planar and arranged in a prismatic relationship with respect to each other. Such, it is possible to fully cover the carrier surface with a closed layer of food stuff bodies.

While mutually adjacent side faces can define substantially right angles therebetween, it is also possible to provide food stuff bodies with polygonal circumference or even food stuff bodies with complicated cross-sectional circumference, e. g. fish-like circumference as frequently used in pavement designs. It is also possible to use different shapes of food stuff bodies on one carrier member. In this case, the food stuff bodies may be shaped like the elements of a puzzle which are different from each other but in combination provide a closed surface.

The dimension of the food stuff bodies is selected according to the expected use. Food stuff bodies to be used as cocktail snacks e. g. may have a cube edge length of 10 to 20 mm, whereas food stuff cubes to be spread over a food preparation may have a cube edge length of 5 to 10 mm. Generally spoken, the volume of the food stuff bodies is preferably between 350 and 16000 mm³ and most preferably in a range of 1000 to 2000 mm³.

In case of cubic food stuff bodies the edge length is preferably in a range of 8 mm to 25 mm and most preferably in a range of 10 to 12 mm.

For making cheese bodies according to the invention, natural cheese, process cheese and fresh cheese can be easily used. These cheese types have the required stability. Natural cheese includes e. g. Emmentaler cheese, Gouda cheese, or Edamer cheese. Proc-

ess cheese includes e. g. a cheese as frequently offered as "Scheibletten", a product of Kraft Jacobs Suchard. Fresh cheese includes e. g. the well-known Philadelphia cheese of Kraft Jacobs Suchard.

Besides cheese bodies other food stuff bodies are taken into consideration, e. g. bodies of liver sausage or liver pudding.

If the respective food product has sticky surface structure, it is proposed that at least a part of the bottom, top, and side faces of the food stuff bodies is provided with a layer of an anticoherence agent or anticaking agent. This anticoherence agent should be physiologically acceptable and neutral in taste. Alternatively, however, it is also possible that agents are used which simultaneously have an anticoherence and a spicing effect.

A most effective anticoherence agent may be powder-shaped or fibre-shaped. It is, however, not excluded that also liquid anticoherence agents are applied and more particularly such anticoherence agents which are subject to a quick hardening effect after application in liquid status.

The carrier member may comprise side walls along at least part of the circumference of the carrier surface. These side walls may have the purpose of strengthening the structure of the carrier elements at a minimum of material and cost consumption in manufacturing the carrier elements. This is particularly true when manufacturing the carrier members from plastics materials.

A further purpose of the side walls may be to better secure the food stuff bodies on the carrier surface, possibly in combination with the covering film. A further purpose of the side walls may be to maintain adjacent food stuff bodies in mutual contact so as to avoid acceleration and friction and deterioration of the surface structure as a result thereof.

Preferably, the height of possible side walls is smaller than the height of the food stuff bodies above the carrier surface. This dimensioning of relative height is of importance for the final consumer for easily removing the food stuff bodies from the carrier surface, particularly in situations in which only a part of the food stuff bodies lying on the carrier surface is to be removed from the carrier surface. The final consumer, e. g. a housewife, may engage the food stuff bodies to be removed along a separation line between two subsequent rows of food stuff bodies with a knife entering between said subsequent rows with a knife entrance depth corresponding to the height difference between the food stuff bodies and the side walls. Then, it is easily possible to shift the food stuff bodies to be removed from the carrier surface beyond a respective side wall. Preferably, the height of the side walls is about 50 to 80 % and more preferably about 75 % of the height of the food stuff bodies above the carrier surface. This is regarded as a good compromise between securing the food stuff bodies, on the one hand, and facilitating removal of the food stuff bodies from the carrier member, on the other hand.

The carrier member and the side walls may be

shaped as a tray, which tray may have a circumferential side wall arrangement along its total circumference. The side walls may be inclined with respect to the carrier surface, e. g. such that they define an angle of more than 90° and preferably less than 110° or 120° with respect to the carrier surface. This inclination is still sufficient to laterally secure the food stuff bodies on the respective carrier member. On the other hand, this inclination facilitates the introduction of the food stuff bodies into the respective tray. Moreover, the removal of the food stuff bodies from the carrier surface is facilitated by this inclination, especially in cases in which - as stated above - the height of the food stuff bodies is larger than the height of the side walls.

For further facilitating the removal of the food stuff bodies from the carrier element by means of a knife as explained above, it may be helpful to provide the side walls with outwardly extending flange means at their respective upper edges. By such flanges a sharp edge contact of the food stuff bottom faces with upper edges of the side walls is avoided so that the food stuff bodies can more easily be displaced beyond the upper edges of the side walls with the bottom faces sliding on the flanges. The flanges may have e. g. a width in a direction parallel to the carrier surface of 1 to 3 mm and more preferably of about 2 mm.

The flanges may also help to stiffen the carrier member in case of being made from flexible plastics material.

A further possibility of stiffening the carrier member is to provide outwardly projecting ribs on respective outer surfaces of the walls. These ribs may also be useful, when the carrier members are stacked before being loaded with food stuff bodies. The ribs can prevent or limit an excessive engagement of two subsequent trays, such as to facilitate removal of a respective tray from a stack of trays during a tray loading operation. Moreover, the ribs may also be helpful when conveying the trays to a loading station and when conveying the loaded trays from the loading station to a wrapping station.

The carrier members can be easily made from plastics foil material, e. g. by thermoforming such as by a deep-drawing operation. This deep-drawing operation easily allows the formation of flanges and/ or ribs.

The carrier members are preferably provided with a rectangular and more particularly with a square-shaped circumference. Due to square-shaped or rectangular circumference the handling of the carrier members is further facilitated and the construction of the handling equipment is simplified. Moreover, rectangular and square-shaped circumference allows tight loading of the respective carrier members, when the food stuff bodies are in accordance with a most common embodiment also of rectangular cross-section.

The carrier surface of the carrier member has e. g. a surface area of 6000 to 35000 mm². Preferably, the smaller values of this range are used for smaller food stuff body volumes and vice versa. For use in a normal family household the surface area of the carrier surface

is preferably square-shaped and has a side length of 70 to 180 mm.

The covering film may be made of flexible plastics material and preferably transparent material. Transparent material gives the advantage of making the food stuff bodies visible for the buying public and also for quality control purposes.

It is to be understood that the covering film may be fixed to the upper edges of the side walls, especially in cases in which the side walls are provided with flanges. This allows a smooth and aesthetic package unit, especially when the covering film is stretched on the top side of the food stuff bodies.

According to a still more preferred embodiment, the covering film is made as a wall portion of a bag completely encapsulating the carrier member and the food stuff bodies. This embodiment has the advantage that the plastics film can easily completely be removed from the carrier member. Complete removal of the plastics film from the carrier member is helpful for facilitating subsequent removal of the food stuff bodies from the carrier surface beyond possible side walls. The removal of the bag is possible without substantial damage to the body of the bag, e. g. by using scissors or by providing easy-opening features such as weakening lines in the body of the bag material. Then, the bag can be opened in such a way as to be further useful for covering a possible rest of food stuff bodies, when this rest of food stuff bodies is to be brought into a refrigerator.

The bag can be constructed in a usual way, e. g. as used in packing the above-mentioned "Scheibletten". Preferably, the bag is made of a tubular film section closed at two opposite ends by welding seams substantially parallel to respective edges of the carrier member. The tubular film may be shaped as a seamless tubular film section cut e. g. from a tubular film extruded from a circular nozzle. Alternatively, the tubular film section may be made from flat film material by at least one longitudinal welding seam.

The bag is preferably constructed with such dimensions as to secure the food stuff bodies on the carrier surface by contact of the top faces of the food stuff bodies with the bag material.

The covering film may be made of usual plastics materials such as polyethylene, polypropylene or copolymers thereof. The selection of the respective plastics material is dependent on the requirements, e. g. the requirements of gas-permeability or -impermeability.

The food stuff bodies may be accommodated within a closed cavity containing a protective gas. In this case the closed cavity should substantially prevent exchange of the protective gas with the surrounding air. The closed cavity principle may be solved by confining the food stuff bodies between the carrier member and the covering film. Alternatively, it may be solved by using a separate bag for obtaining the closed cavity.

The protective gas may be one of nitrogen, carbon dioxide, and mixtures thereof.

The food stuff bodies may be arranged in one single

layer on the carrier surface. Alternatively, it is also possible to provide a plurality of layers one above the other on the carrier surface. The various layers may be stacked one above the other in direct food stuff contact between subsequent layers. Alternatively, a thin separation foil may be provided between subsequent layers contained within one single package. The use of the above-mentioned separating agents allows, however, to avoid such separating layers.

According to a preferred embodiment of the invention, a packaging unit comprises a circumferential group of food stuff bodies. These food stuff bodies of the circumferential group are laterally positioned with respect to the carrier members by a circumferential side wall arrangement of the carrier member. Further food stuff bodies within a central field are surrounded by the circumferential group of food stuff bodies and are laterally secured by the circumferential group of food stuff bodies. Thus, one can maintain intimate contact between adjacent food stuff bodies throughout the layer even when the package is subject to heavy acceleration during shipping and distribution.

According to a further aspect of the invention, a multilayer cheese package may be assembled by a plurality of cheese packages as described before. These cheese packages within a multiple layer cheese package may be stacked one above the other with substantially mutually aligned circumferential edges. The plurality of cheese packages may be accommodated within an outer container which secures the individual food stuff packages with respect to each other in stacked relationship. The outer container may be e. g. a cardboard box or preferably again a bag, as described before in connection with packing of the individual packaging units.

A further object of the present invention is to provide a method for industrially manufacturing a food stuff package with a plurality of food stuff bodies and more particularly cheese bodies which are available e. g. as snacks or as an additive for food preparations.

In view of this object the method comprises:

a) providing a disc-shaped preproduct of said food stuff having main faces and circumferential faces;

b) providing a cutting grid having an axis of food stuff passage and comprising a plurality of mutually adjacent passage cells, said passage cells being confined and separated from each other by knife sections, said knife sections having upstream knife edges defining an upstream face of said cutting grid and further having downstream knife edges defining a downstream face of said cutting grid;

c) positioning said disc-shaped preproduct onto the upstream face of said cutting grid;

d) pressing said disc-shaped preproduct by a first substantially uninterrupted pressing face into the

cutting cells of said cutting grid by approaching said first pressing face toward said upstream face of said cutting grid, substantially until said first pressing face engages said upstream face of said cutting grid, thus obtaining a plurality of food stuff bodies from said disc-shaped preproduct having respective cross-sectional areas corresponding to respective cross-sectional areas of said cutting cells, said food stuff bodies being retained within said cutting cells;

e) replacing said first substantially uninterrupted pressing face by a second slotted pressing face, said second slotted pressing face having slots aligned with said knife sections and having a depth substantially sufficient to receive the full height of said knife sections along said food stuff passage axis, said slots confining ejecting plungers aligned with respective cutting cells, said food stuff bodies remaining within said cutting cells during said replacement;

f) moving said second slotted pressing face along said food stuff passage axis with said ejecting plungers entering into respective cutting cells and thereby ejecting said food stuff bodies with their respective bottom faces toward said carrier surface.

The disc-shaped preproduct may be provided by cutting from a food stuff bar in a disc cutting station and may be transferred from said disc cutting station to the upstream face of the cutting grid.

The weight of the food product provided for loading a respective carrier member may be corrected to the desired value. This may be done by controlling the thickness of the disc-shaped preproducts in the disc cutting station.

The thickness of the disc-shaped preproduct may be selected in response to weight measuring of preceding disc-shaped preproducts. The weight measuring may be performed along a way of the preceding disc-shaped preproducts from the disc cutting station to the cutting grid.

More particularly, the thickness of the preproduct disc may be selected by conveying a food stuff bar with a leading end portion thereof against abutment means, and the position of these abutment means in conveying direction with respect to a disc cutting knife may be controlled in response to measuring the weight of the preceding disc-shaped preproduct or preproducts cut from the food stuff bar.

The food stuff bodies may be provided on at least part of their respective top, bottom and side faces with an anticoherence agent or anticaking agent. E. g. the food stuff bodies may be treated with a powder- or fibre-shaped anticoherence agent. The anticoherence agent may be provided on at least one of said top and bottom faces by treating at least one of the main faces of the respective disc-shaped preproduct. The treatment of

the at least one main face may be performed during the transfer of the respective disc-shaped preproduct to the cutting grid. This may be done e. g. during the passage of a respective disc-shaped preproduct through a powder fog chamber.

The side faces may be treated with anticoherence agent by applying the anticoherence agent onto the knife sections of the cutting grid after ejection of a group of food stuff bodies from the cutting grid and before positioning a subsequent disc-shaped preproduct onto the cutting grid. A powder- or fibre-shaped anticoherence agent may be applied to the knife sections by dipping the cutting grid into a bed of powder- or fibre-shaped anticoherence agent.

Cutting residues obtained at the cutting grid may be removed from the cutting grid periodically, preferably after each cutting step performed by the cutting grid. The cutting residues may be removed e. g. by a cleaning gas jet and possibly collected in a residue receiving container. Surplus treating agent may be removed from the knife sections after applying the anticoherence agent thereto. The surplus anticoherence agent may be removed by a cleaning gas jet and may be, possibly, collected in a collector vessel.

The cutting grid may be one of a group of cutting grids mounted on a moving carrier. This moving carrier may be used for transferring each of said group of cutting grids one after the other to a plurality of stations including a preproduct inlet station, a first pressing station comprising said first uninterrupted pressing face and a second pressing station comprising said slotted pressing face.

The food stuff bodies lying on the carrier surface may be covered after having been positioned on the carrier surface by a covering film. This covering film may be applied as part of a bag enclosing both the carrier member and the food stuff bodies.

The food stuff bodies may be accommodated within a packaging cavity substantially closed with respect to surrounding atmosphere, and this packing cavity may be filled with a protective gas.

The food stuff packages may be arranged in groups of food stuff packages. These groups of food stuff packages may be encapsulated within an outer common container.

The food stuff bodies may be positioned on the carrier surface with mutual lateral contact. This lateral contact may be obtained or maintained by using a carrier member with downwardly and inwardly inclined side walls.

The preproduct may be conveyed on a powder-permeable conveyor through a powder fog chamber for applying the anticoherence agent to the main faces of the preproduct.

According to a further aspect of the invention, an apparatus for manufacturing a food stuff package is proposed. The food stuff package to be obtained comprises at least one carrier member having a carrier surface and a plurality of food stuff bodies having

respective top, bottom and side faces. The food stuff bodies are positioned in at least one layer with their respective bottom faces on the carrier surface.

The apparatus comprises:

a) preproduct provision means for providing a disc-shaped preproduct of the respective food stuff;

b) first conveyor means extending from said preproduct provision means toward preproduct subdividing means, the preproduct subdividing means being adapted for subdividing the preproduct into the food stuff bodies;

c) food stuff body transferring means for transferring the food stuff bodies from the subdividing means onto the carrier surface;

d) second conveyor means for conveying the carrier member with the food stuff bodies positioned thereon into an encapsulating station.

Encapsulating means are provided in the encapsulating station for encapsulating the food stuff bodies positioned on the carrier member.

The preproduct provision means may comprise bar conveyor means moving a food stuff bar along a conveying direction parallel to a longitudinal axis of the food stuff bar towards movable abutment means. A bar cutting knife movable in a direction substantially orthogonal with respect to the conveying direction of the bar conveyor means, and actuating means for actuating the bar cutting knife and the abutment means in a predetermined time sequence may be provided.

The distance of the abutment means and of the bar cutting knife along the conveying direction of the bar conveyor means may be variable. This distance may be variable in response to weight measuring of preceding disc-shaped preproducts cut from the bar. Preproduct weighing means may be provided between the bar conveyor means and the preproduct subdividing means, said weighing means being operatively connected with distance control means controlling the distance between the bar cutting knife and the abutment means.

Main face treatment means may be provided between the preproduct provision means and the preproduct subdividing means. This main face treating means may be used for applying an anticoherence agent to the main faces. These main face treating means may comprise a powder fog chamber, and the said first conveyor means may extend through the powder fog chamber. The first conveyor means may comprise a powder-permeable preproduct supporting face adapted to expose both main faces of a disc-shaped preproduct to powder fog treatment.

The preproduct subdividing means may comprise a cutting grid and pressure means for urging the disc-shaped preproduct through the cutting grid.

The cutting grid may be mounted on a movable grid

carrier. Then, the cutting grid may be movable by the grid carrier through a plurality of stations including a preproduct inlet station in which the disc-shaped preproduct is positioned on the cutting grid, a grid entrance station in which the preproduct is pressed into cutting cells of the cutting grid and a food stuff body ejecting station in which the food stuff bodies are located on the carrier surface of the carrier member.

A carrier supply conveyor may be provided for conveying the carrier members from a carrier member supply to the food stuff body ejecting station. The carrier supply conveyor may join the second conveyor means.

The plurality of stations may further comprise a cutting grid treatment station for applying a treatment agent to the cutting grid so that the treatment agent may be hereupon transferred from the cutting grid to side faces of the food stuff bodies.

The plurality of stations may further comprise a grid cleaning station for cleaning the cutting grid by removing cutting residues of the food stuff.

Gas filling means may be allocated to the encapsulating station for introducing protective gas into the food stuff package.

The apparatus may further comprise a stacking station for stacking a plurality of at least and preferably two food stuff packages and securing the stacked food stuff packages with respect to each other.

For further features of the invention it is referred to the attached claims which are to be understood as a part of the disclosure.

Further details of the invention will be subsequently described by reference to the accompanying drawings in which:

- 35 Fig. 1 shows a carrier member with an associated layer of cheese bodies before being loaded onto the carrier member;
- Fig. 2 shows a cheese body;
- 40 Fig. 3 shows a finished packaging unit;
- Fig. 4 shows a side view of a multilayer cheese packaging unit composed of two individual packaging units;
- 45 Fig. 5 shows a first section of an apparatus for manufacturing cheese packaging units according to Figs. 1 to 4;
- 50 Fig. 6 shows a second section of the apparatus, i. e. a section in which disc-shaped preproducts are treated with anticoherence agents on their main faces in combination with an entrance station in which the disc-shaped preproducts are located on a cutting grid;
- 55 Fig. 7 shows a plane view of a further section of the apparatus in which the disc-shaped pre-

products are cut into individual cheese bodies located on carrier members and encapsulated;

- Fig. 8 shows a partial end view according to line VIII-VIII of Fig. 7 and Fig. 6;
- Fig. 9 shows a section according to line IX-IX of Fig. 7;
- Fig. 10 shows a section according to line X-X of Fig. 7;
- Fig. 11 shows a section according to line XI-XI of Fig. 7;
- Fig. 12 shows a section according to line XII-XII of Fig. 7;
- Fig. 13 shows a section according to line XIII-XIII of Fig. 7;
- Fig. 14 shows a diagrammatic view of a folding station in which the loaded carrier members are encapsulated by a wrapping film or foil;
- Fig. 15 shows a further station in which the encapsulated packaging units are separated from each other and closed by welding seams and
- Fig. 16 shows a combination of two apparatus into an overall plant in which multiple layer cheese packaging units are stacked and encapsulated.

In Fig. 1 a carrier member shaped as a tray is designated by 10. This tray comprises a carrier surface 12 and a side wall arrangement 14. The side walls 14 are inclined with respect to the carrier surface 12 by an angle α . The upper edges of the side walls 14 are provided with flanges 16 directed substantially parallel to the carrier surface 12 in outward direction with respect to the tray 10. The side walls 14 are provided on their outer faces with ribs 18 corresponding to recesses 19 on the inner faces of the side walls. The tray 10 is manufactured from a stiff plastics film by a punching and deep-drawing operation during which the ribs 18 and the flanges 16 are obtained. The tray 10 is to be loaded with a layer 20 of individual cheese bodies 22 having cubic shape. One of these cubic cheese bodies 22 is shown in Fig. 2 in larger scale. The cheese bodies have a structural stability which is sufficient for maintaining the shape of the cheese bodies during preparation, loading, shipping, distributing, and preparation for final consumption. One can further see from Fig. 2 that the cubic cheese bodies 22 are provided with a surface structure consisting of respective layers 24 of granular or fibrous anticoherence agent, such as microcrystalline

cellulose or starch. These layers of anticoherence agent allow the cubic cheese bodies 22 to be brought into intimate contact with each other as shown in Fig. 1 without the risk of sticking to each other in a substantial degree. Thus, the layer 20 can be dimensioned such as to fully cover the carrier surface 12 of the carrier member 10 without separation of the cheese bodies from each other. In Fig. 2, the side faces of the cubic cheese body 22 are designated by 26, whereas the top face and the bottom face are designated by 28 and 30, respectively. The bottom face 30 may also be covered by a layer of anticoherence agent so as to prevent a sticking of the cubic cheese body to the carrier surface 12.

According to Fig. 3, the loaded carrier member 10 is encapsulated by a plastics material bag 32. This bag 32 is made from a section 34 of a tubular film which has been closed at both ends thereof by welding seams 36 parallel to opposite flanges 16. The tubular material is made from a flat material which has been welded along a welding seam 38 in longitudinal direction of the tubular material.

The packaging unit as shown in Fig. 3 is designated by 40 in Fig. 3.

In Fig. 4 one can see two packaging units 40a and 40b as shown in Fig. 3. The two packaging units 40a and 40b are stacked one above the other and are wrapped by an outer container 42. This outer container 42 has the same construction as the bag 32 shown in Fig. 3. Thus, the two packaging units 40a and 40b are secured in the position as shown in Fig. 4 with respect to each other.

As shown in Fig. 3, the cubic cheese bodies are secured on the carrier surface 12 by the bag 32. The bag 32 is dimensioned such as to prevent separation of the cubic cheese bodies 22 from the carrier surface 12. The bag 32 is substantially completely closed and contains a protective atmosphere of e. g. nitrogen.

In Fig. 5, there is shown a bar conveyor 44 comprising rollers 46 and a belt 48. The bar conveyor 44 is intended for conveying a cheese bar 50 along the bar axis 52. The cheese bar 50 is urged by the bar conveyor 44 against two abutment plates 54. The abutment plates 54 are pivotally mounted by pivot shaft 56; they can swing along the arrows 58. A disc cutting knife 60 is allocated to the abutment plates 54 in a distance therefrom which is indicated as a in Fig. 5. The disc cutting knife 60 is movable along the arrows 62 through the cheese bar 50 down to the upper surface of the conveyor belt 48 such that a disc-shaped preproduct 64 can be cut from the cheese bar 50. When the disc cutting knife 60 has cut the disc-shaped preproduct 64 along the cutting face 66, the abutment plates 54 swing along the arrows 58 thus allowing the transfer of the disc-shaped preproduct 64 by a transferring mechanism 66 to a further belt conveyor 68. The further belt conveyor 68 is constituted by rollers 70 and two narrow conveyor belts 72. The transferring mechanism 66 comprises a vacuum gripper 74 which transfers by a linear movement 76 and two rotational movements 78,80 the disc-shaped pre-

product 64 from the cutting position to the position on the belt conveyor 68.

Subsequent disc-shaped preproducts 64 are moved on the belt conveyor 68 in direction of the arrow 82. The narrow belts 72 are supported by a weighing apparatus 84 which is adapted for weighing the average weight of the disc-shaped preproducts 64. The weighing mechanism 84 is operatively connected with an adjusting mechanism 86. This adjusting mechanism 86 moves the pivoting shaft 56 along arrow 88 for adjusting the width of the disc-shaped preproduct. The width is adjusted such that the weight of the disc-shaped preproduct 64 is maintained at a predetermined value, irrespective of irregularities of the cheese bar 50. Thus, one can make sure that the weight of the subsequent disc-shaped preproduct 64 is constant, and this is necessary for making sure that the filling weight of the packaging units 40 as shown in Fig. 3 is also constant and corresponds to a predetermined value declared on the bag 32 by a print (not shown).

In Fig. 6 one can recognize a downstream portion of the conveyor 68 with the narrow belts 72. One can see that the conveyor 68 runs through a powder fog chamber 90. This powder fog chamber 90 is provided with an upper powder sprayer unit 92 and a lower powder sprayer unit 94. The upper powder sprayer unit 92 is completely covered by the walls of the chamber 90. The lower powder sprayer unit 94 may be covered in a similar way by walls not shown. Thus, the main faces 64a and 64b as shown in Fig. 5 of the disc-shaped preproduct 64 are exposed to anticoherence powder sprayed from the powder sprayer units 92 and 94. The upstream and downstream walls of the powder fog chamber 90 are provided with flexible doors 96 and 98 which allow the disc-shaped preproducts 64 to pass through the powder fog chamber without substantial loss of powder fog to the atmosphere.

From Figs. 6 and 7 one can see that the downstream end of the belt conveyor 68 joins a rotary table 100. The rotary table 100 is rotatable about an axis B and is provided with six cutting grids 102I to 102VI. The cutting grids 102I to 102VI are located in Fig. 7 in six mutually subsequent stations Stat. I to Stat. VI. In Stat. I a disc-shaped preproduct 64 has been loaded on the cutting grid 102I, as one can see from Fig. 8.

Loading blades 104a and 104b are provided above the cutting grid 102I. The disc-shaped preproduct 64 moves on the belt conveyor 68 onto the loading blades 104a and 104b into contact with stoppers 106a and 106b (see Fig. 6). When the leading edge of the disc-shaped preproduct 64 abuts the stoppers 106a and 106b, the loading blades 104a and 104b move outwards with respect to the center of the cutting grid 102I in the direction of the arrows 108a and 108b. Thus, the disc-shaped preproduct 64 is loaded on the upper face 110 of the cutting grid 102I, as shown in Fig. 8 in more detail. The rotary table 100 is rotated in angular steps of 60°.

In Fig. 9 corresponding to Stat. II the disc-shaped preproduct 64 is located below a first cutting block 112

which has a plane, uninterrupted pressing face 114. In Stat. II the cutting block 112 moves downward, until the pressing face 114 abuts the upper face of the cutting grid 102I. Thus, the disc-shaped preproduct 64 is pressed into the cutting cells 116 which are separated from each other by knife sections 118. This status is shown in Fig. 10 corresponding to Stat. III. Possible residues of the preproduct which might have collected at the upper face 110 are removed in Stat. III by a cleaning jet 120 into a residue collector pan 122. This cleaning action is, however, avoidable, if no substantial residues are found on the upper face 110.

In Fig. 11 corresponding to Stat. IV, the cutting grid 102I has been located below a second cutting block 124. This cutting block 124 has a pressing face 126. This pressing face 126 is provided with slots 128 aligned with the knife sections 118. In Fig. 11, the cutting block 124 makes a downward and upward movement according to arrow 130. Fig. 11 shows the status after the cutting block has made a downward and an upward movement such that cheese bodies 22 have been loaded on the carrier surface 12 of the tray 10. One can see from Fig. 7 that the trays 10 are conveyed in empty condition to Stat. IV, where they are loaded as seen in Fig. 11. The transport of the empty trays 10 to Stat. IV is performed by a transfer mechanism 132 equipped with a suction plate 134 from a tray supply 136 and is continued by an empty tray conveyor 138 leading to Stat. IV. In Stat. IV the trays 10 are delivered to a further conveyor 140 the upstream end of which is located below Stat. IV as shown in Fig. 11. The loaded trays 10 are moved by the conveyor 140 in the direction of arrow 142 through an encapsulating station 144 and a sealing and separating station 146 as seen in Fig. 7 to a delivery station (not shown) where the loaded and encapsulated trays may be packed into further containers for shipping.

When the cheese bodies 22 have been loaded onto the tray 10, as shown in Fig. 11, by ejecting plungers 148 of the pressing block 124, the cutting cells 116 extending between the upper face 110 and the lower face 150 are empty. This condition is shown in more detail in Fig. 12 corresponding to Stat. V. In this Stat. V some cheese residues may stick to the knife sections 118. These residues may be removed by cleaning gas jets 152 and may be collected in a collector tray 154 located below the cutting grid 102I.

In Stat. VI as shown in Fig. 13 the cutting grid 102I has been moved into a position vertically aligned with a treatment bed 156. This treatment bed 156 is filled with a coherence preventing powder 158. The treatment bed 156 is movable upwards and downwards along the arrow 160 such that the knife sections 118 are dipped into the anticoherence powder 158 by at least part of their height between the upper face 110 and the lower face 150 of the cutting grid 102I. Thus, the knife sections 118 are provided with respective layers of anticoherence powder for the next cutting operation to be expected, when the cutting grid 102I will again have

arrived in Stat. II. Thus, the spreading of anticoherence powder on the side faces 26 (as shown in Fig. 2) is warranted, as shown in Fig. 13. Surplus anticoherence powder may be removed from the knife sections 118 by a gas jet 119. This may be done in a separate station. E. g. the cleaning operation of Station III may be avoided such that a separate station of totally six stations becomes available for the removing of surplus anticoherence powder subsequent to the dipping station.

The encapsulating station 144 is shown in Fig. 14. A wrapping film 162 is introduced between the upper face of the conveyor 140 and the lower main face 64b of the respective disc-shaped preproduct 64. The wrapping film 162 is folded by folding blades 164 into a circularly closed bag 32, such as shown in Fig. 3. The bag is longitudinally closed by a welding seam 38. For providing this welding seam 38 a welding beam 166 and a welding roller 168 are provided. A gas filling tube or a gas flushing tube 170 is provided for filling a protective gas into the bag 32.

According to Fig. 15, the bag 32 is closed by a welding beam 172 at the ends thereof, thus obtaining the welding seams 36 as shown in Fig. 3. The welding beam 172 is combined with a separating knife 174 for separating subsequent packaging units 40 from each other. The belt conveyor 140 as shown in Fig. 14 brings the packaging units 40 to a delivery station in the direction of arrow 176.

In Fig. 16, one can recognize two rotary tables 100A and 100B as shown at 100 in Fig. 7. Both rotary tables 100A and 100B join a belt conveyor 68A and 68B, respectively, as shown in Figs. 6 and 7. Both rotary tables 100A and 100B are followed by an encapsulating station 144A and 144B, respectively. The belt conveyors 140A and 140B converge into an overlapping relationship, as one can see in the right-hand part of Fig. 16. Packaging units 40A and 40B are stacked one above the other in a stacking and packaging station 178 in which the double packaging units 42, as shown in Fig. 4, are assembled and encapsulated.

Claims

1. A food packaging unit (40) comprising at least one carrier member (10) having a carrier surface (12), a plurality of food stuff bodies (22), and more particularly cheese bodies (22) having respective bottom, top and side faces (30,28,26), said food stuff bodies (22) being positioned in at least one layer (22) with their respective bottom faces (30) on said carrier surface (12) and having body contact with each other by respective side faces (26), said food stuff bodies (22) having a body structure of sufficient stability for substantially maintaining their respective shape during packing, shipping, distribution and use, said food stuff bodies (22) further having a surface structure (24) preventing substantial coherence of mutually contacting side faces (26), said food stuff bodies (22) being covered and secured with respect to said carrier surface (12) by a covering film (32).
2. A food packaging unit as set forth in claim 1, said food stuff bodies (22) having substantially planar top and bottom faces (28,30) and further having side faces (26) extending in a substantially orthogonal direction with respect to said carrier surface (12).
3. A food packaging unit as set forth in claim 2, said side faces (26) of a food stuff body (22) being substantially planar and arranged in prismatic relationship with respect to each other.
4. A food packaging unit as set forth in claim 3, mutually adjacent side faces (26) defining substantially right angles.
5. A food packaging unit as set forth in one of claims 1 to 4, said food stuff bodies (22) having a volume of 350 to 16000 mm³, preferably a volume of 1000 to 2000 mm³ (one thousand to two thousand).
6. A food packaging unit as set forth in one of claims 1 to 5, said food stuff bodies (22) having cubic shape with a side length of 8 mm to 25 mm, preferably 10 to 12 mm.
7. A food packaging unit as set forth in one of claims 1 to 6, said food stuff bodies (22) consisting of one of natural cheese, process cheese, and fresh cheese.
8. A food packaging unit as set forth in one of claims 1 to 7, at least part of said bottom, top and side faces (30,28,26) of respective food stuff bodies (22) being provided with a layer (24) of an anticoherence agent which is physiologically acceptable and neutral in taste.
9. A food packaging unit as set forth in claim 8, said anticoherence agent being powder-shaped or fibre-shaped.
10. A food packaging unit as set forth in claim 8 or 9, said anticoherence agent consisting of one of microcrystalline cellulose and starch.
11. A food packaging unit as set forth in one of claims 1 to 10, said carrier member (10) comprising side walls (14) along at least part of the circumference of said carrier surface (12).
12. A food packaging unit as set forth in claim 11,

- said side walls (14) having a height smaller than the height of said food stuff bodies (22) above said carrier surface (12).
13. A food product packaging unit as set forth in claim 11 or 12, said height of said side walls (14) above said carrier surface (12) being about 50 to 80 %, preferably about 75 %, of the height of said food stuff bodies (22) above said carrier surface (12). 5
14. A food packaging unit as set forth in one of claims 11 to 13, said carrier member (10) and said walls (14) being shaped as a tray. 10
15. A food packaging unit as set forth in one of claims 11 to 14, said side walls (14) defining an angle α of more than 90° and preferably less than 110° with respect to said carrier surface (12). 15
16. A food packaging unit as set forth in one of claims 11 to 15, said side walls (14) being provided with outwardly extending flange means (16) at their respective upper edges. 20
17. A food packaging unit as set forth in claim 16, said flanges having a width in a direction substantially parallel to said carrier surface (12) of 1 to 3 mm, preferably about 2 mm. 25
18. A food packaging unit as set forth in one of claims 11 to 17, said side walls (14) being provided with outwardly projecting ribs (18) on their respective outer surfaces, said ribs (18) being shaped for at least one of stiffening and stacking purpose. 30
19. A food packaging unit as set forth in one of claims 1 to 18, said carrier member (10) being made of plastics material. 35
20. A food packaging unit as set forth in one of claims 1 to 19, said carrier member (10) being shaped by thermoforming such as deep drawing. 40
21. A food packaging unit as set forth in one of claims 1 to 20, said carrier member (10) having a substantially rectangular circumference. 45
22. A food packaging unit as set forth in claim 21, said carrier member (10) having a square-shaped circumference. 50
23. A food packaging unit as set forth in one of claims 1 to 22, said carrier surface (12) having a surface area of 6000 to 35000 mm², the smaller values of the surface area preferably corresponding to the smaller values of the cheese body volume as indicated above. 55
24. A food packaging unit as set forth in claim 23, said carrier surface (12) being substantially square-shaped and having a side length of 70 to 180 mm, preferably 80 to 150 mm.
25. A food packaging unit as set forth in one of claims 1 to 24, said covering film (32) being made of flexible plastics material.
26. A food packaging unit as set forth in one of claims 1 to 25, said covering film (32) being made of transparent material.
27. A food packaging unit as set forth in one of claims 1 to 26, said covering film (32) being a wall portion of a bag (32) completely encapsulating said carrier member (10) and said food stuff bodies (22).
28. A food packaging unit as set forth in claim 27, said bag (32) being made of a tubular film section closed at two opposite ends by welding seams (36) substantially parallel to respective edges of said carrier member (10).
29. A food packaging unit as set forth in claim 28, said tubular film section (34) being shaped as a seamless tubular film section.
30. A food packaging unit as set forth in claim 28, said tubular film section (34) being made from flat film material by at least one longitudinal welding seam (38).
31. A food packaging unit as set forth in one of claims 27 to 30, said bag (32) having such dimensions as to secure said food stuff bodies (22) on said carrier surface (12).
32. A food packaging unit as set forth in one of claims 1 to 31, said covering film (32) being made of one of polyethylene, polypropylene, and copolymers thereof.
33. A food packaging unit as set forth in one of claims 1 to 32, said food stuff bodies (22) being accommodated within a closed cavity (32) containing a protective

- gas, said closed cavity (32) substantially preventing exchange of said protective gas with surrounding air.
34. A food packaging unit as set forth in claim 33, said closed cavity (32) being confined by said carrier member (10) and said covering film (32).
35. A food packaging unit as set forth in claim 33, said closed cavity (32) being confined by a bag (32).
36. A food packaging unit as set forth in one of claims 33 to 35, said protective gas being one of nitrogen, carbon dioxide and mixtures thereof.
37. A food packaging unit as set forth in claim 36, said food stuff bodies (22) being arranged in one single layer (20) on said carrier surface (12).
38. A food packaging unit as set forth in one of claims 1 to 37, said food stuff bodies (22) comprising a circumferential group of food stuff bodies (22), said food stuff bodies (22) of said circumferential group being laterally positioned with respect to said carrier member (10) by a circumferential side wall arrangement (14) of said carrier member (10), further food stuff bodies (22) within a field of food stuff bodies (22) surrounded by said circumferential group of food stuff bodies (22) being laterally positioned by said circumferential group of food stuff bodies (22).
39. A multiple layer food stuff package comprising a plurality of food stuff packages as set forth in one of claims 1 to 38, said food stuff packages (40) of said plurality of food stuff packages (40) being stacked one above the other with substantially mutually aligned circumferential edges, said plurality of food stuff packages (40) being accommodated within an outer container (42) securing said food stuff packages (40) with respect to each other in stacking relationship.
40. A multiple layer food stuff package as set forth in claim 39, said outer container (42) being a bag of film material.
41. A method of manufacturing a food stuff package (40), said food stuff package (40) comprising at least one carrier member (10) having a carrier surface (12) and a plurality of food stuff bodies (22) having respective top, bottom and side faces (28,30,26), said food stuff bodies (22) being positioned in at least one layer (20) with their respective bottom faces (30) on said carrier surface (12),
- said method comprising
- a) providing a disc-shaped preproduct (64) of said food stuff having main faces(64a,64b) and circumferential faces;
- b) providing a cutting grid (102) having an axis of food stuff passage and comprising a plurality of mutually adjacent cutting cells (116), said cutting cells (116) being confined and separated from each other by knife sections (118), said knife sections (118) having upstream knife edges defining an upstream face (110) of said cutting grid (102) and further having downstream knife edges defining a downstream face (150) of said cutting grid (102);
- c) positioning said disc-shaped preproduct (64) onto the upstream face (110) of said cutting grid (102);
- d) pressing said disc-shaped preproduct (64) by a first substantially uninterrupted pressing face (114) into the cutting cells (116) of said cutting grid (102) by approaching said first pressing face (114) toward said upstream face (110) of said cutting grid (102), substantially until said first pressing face (114) engages said upstream face (110) of said cutting grid (102), thus obtaining a plurality of food stuff bodies (22) from said disc-shaped preproduct (64) having respective cross-sectional areas corresponding to respective cross-sectional areas of said cutting cells (116), said food stuff bodies (22) being retained within said cutting cells (116);
- e) replacing said first substantially uninterrupted pressing face (114) by a second slotted pressing face (126), said second slotted pressing face (126) having slots (128) aligned with said knife sections (118) and having a depth substantially sufficient to receive the full height of said knife sections (118) along said food stuff passage axis, said slots (128) confining ejecting plungers (148) aligned with respective cutting cells (116), said food stuff bodies (22) remaining within said cutting cells (116) during said replacement;
- f) moving said second slotted pressing face (126) along said food stuff passage axis with said ejecting plungers (148) entering into respective cutting cells (116) and thereby ejecting said food stuff bodies (22) with their respective bottom faces (30) toward said carrier surface (12).
42. A method as set forth in claim 41, said disc-shaped preproduct (64) being provided by cutting from a food stuff bar (50) in a disc cutting station (Fig. 5) and transferring the respective disc-shaped preproduct (64) from said disc cutting station to the upstream face (110) of said cutting grid

- (102).
43. A method as set forth in claim 41 or 42, the weight of said food product provided for loading a respective carrier member (10) being corrected to a desired value. 5
44. A method as set forth in claim 43, the weight being corrected by controlling the thickness of said disc-shaped preproducts (64) in a disc cutting station (Fig. 5). 10
45. A method as set forth in claim 44, the thickness (a) of the disc-shaped preproduct (64) being selected in response to weight measuring of preceding disc-shaped preproducts (64), said weight measuring being performed along a way of said preceding disc-shaped preproducts (64) from said disc cutting station (Fig. 5) to the cutting grid (102). 15 20
46. A method as set forth in claim 45, the thickness (a) of the disc-shaped preproduct(64) being selected by conveying a food stuff bar (50) with a leading end portion thereof against abutment means (54), the position of said abutment means (54) in conveying direction with respect to a disc cutting knife (60) being controlled in response to measuring the weight of the preceding disc-shaped preproduct (64) cut from the food stuff bar (50). 25 30
47. A method as set forth in one of claims 41 to 46, said food stuff bodies (22) being provided on at least part of their respective top, bottom and side faces (28,30,26) with an anticoherence agent. 35
48. A method as set forth in claim 47, said food stuff bodies (22) being treated with a powder- or fibre-shaped anticoherence agent. 40
49. A method as set forth in claim 47 or 48, said anticoherence agent being provided on at least one of said top and bottom faces (28,30) by treating at least one of said main faces (64a,64b) of the respective disc-shaped preproduct (64). 45
50. A method as set forth in claim 49, said treatment of said at least one main face (64a,64b) being performed during the transfer of the respective disc-shaped preproduct (64) to said cutting grid (102). 50
51. A method as set forth in claim 50, said treatment of said at least one main face (64a,64b) being performed during the passage of a respective disc-shaped preproduct (64) through a powder fog chamber (90). 55
52. A method as set forth in one of claims 47 to 51,
- said side faces (26) being treated with anticoherence agent by applying said anticoherence agent onto said knife sections (118) of said cutting grid (102) after ejection of a group of food stuff bodies (22) from the cutting grid (102) and before positioning a subsequent disc-shaped preproduct (64) onto the cutting grid (102).
53. A method as set forth in claim 52, a powder- or fibre-shaped anticoherence agent being applied to said knife sections (118) by dipping said cutting grid (102) into a bed (156) of powder- or fibre-shaped anticoherence agent (158).
54. A method as set forth in one of claims 41 to 53, cutting residues obtained at said cutting grid (102) being removed from said cutting grid (102) periodically, preferably after each cutting step performed by said cutting grid (102).
55. A method as set forth in claim 54, cutting residues being removed by a cleaning gas jet (152) and possibly collected in a residue receiving container (154).
56. A method as set forth in one of claims 52 to 55, surplus treating agent being removed from said knife sections (118) after applying the anticoherence agent (158) thereto.
57. A method as set forth in claim 56, said surplus anticoherence agent being removed by a cleaning gas jet (119) and being, possibly, collected in a collector vessel (156).
58. A method as set forth in one of claims 41 to 57, said cutting grid (102) being one of a group of cutting grids (102I-102VI) mounted on a moving carrier (100), said moving carrier (100) transferring each of said group of cutting grids (102I-102VI) one after the other to a plurality of stations (Stat.I-Stat.IV) including a preproduct inlet station (Stat.I), a first pressing station (Stat.II) comprising said first uninterrupted pressing face (114) and a second pressing station Stat. IV) comprising said slotted pressing face (126).
59. A method as set forth in one of claims 41 to 58, said food stuff bodies (22) lying on said carrier surface (12) being covered after having been positioned on said carrier surface (12) by a covering film (32).
60. A method as set forth in claim 59, said covering film (32) being applied as part of a bag (32) enclosing both said carrier member (10) and said food stuff bodies (22).
61. A method as set forth in claim 59 or 60,

said food stuff bodies (22) being accommodated within a packing cavity substantially closed with respect to surrounding atmosphere, said packing cavity being filled with a protective gas.

62. A method as set forth in one of claims 41 to 61, said food stuff packages (40) being arranged in groups, preferably in pairs, of food stuff packages (40A,40B), said groups of food stuff packages (40A,40B being encapsulated within an outer common container (42).

63. A method as set forth in one of claims 41 to 62, said food stuff bodies (22) being positioned on said carrier surface (12) with mutual lateral contact.

64. A method as set forth in claim 63, said lateral contact being obtained or maintained by using a carrier member (10) with downwardly and inwardly inclined side wall means (14).

65. A method as set forth in one of claims 51 to 64, said preproduct (64) being conveyed on a powder-permeable conveyor means (68) through said powder fog chamber (90).

66. An apparatus for manufacturing a food stuff package (40), said food stuff package (40) comprising at least one carrier member (10) having a carrier surface (12) and a plurality of food stuff bodies (22) having respective top, bottom and side faces (28,30,26), said food stuff bodies (22) being positioned in at least one layer (20) with their respective bottom faces (30) on said carrier surface (12), said apparatus comprising

a) preproduct provision means (Fig. 5) for providing a disc-shaped preproduct (64) of said food stuff;

b) first conveyor means (68) extending from said preproduct provision means (Fig. 5) toward preproduct subdividing means (102,112), said preproduct subdividing means (102,112) being adapted for subdividing said disc-shaped preproduct (64) into said food stuff bodies (22);

c) food stuff body transferring means (124) for transferring said food stuff bodies (22) from said subdividing means (102,112) onto said carrier surface (12);

d) second conveyor means (140) for conveying said carrier member (10) with said food stuff bodies (22) positioned thereon into an encapsulating station (144).

67. An apparatus as set forth in claim 66, further comprising encapsulating means (164) in said encapsulating station (144) for encapsulating said food stuff bodies (22) positioned on said carrier

member (10).

68. An apparatus as set forth in claim 67, said preproduct provision means (Fig. 5) comprising bar conveyor means (44) moving a food stuff bar (50) along a conveying direction (52) parallel to a longitudinal axis of said food stuff bar (50) towards movable abutment means (54), a bar cutting knife (60) movable in a direction substantially orthogonal with respect to the conveying direction (52) of said bar conveyor means (44), and actuating means for actuating said bar cutting knife (60) and said abutment means (54) in a predetermined time sequence.

69. An apparatus as set forth in claim 68, the distance of said abutment means (54) and of said bar cutting knife (60) along the conveying direction (52) of said bar conveyor means (44) being variable.

70. An apparatus as set forth in claim 69, said distance being variable in response to the measuring of preceding disc-shaped preproducts (64) cut from said bar (50).

71. An apparatus as set forth in claim 70, a preproduct weighing means (84) being provided between said bar conveyor means (44) and said preproduct subdividing means (102,112), said weighing means (84) being operatively connected with distance control means (86) controlling the distance between said bar cutting knife (60) and said abutment means (54).

72. An apparatus as set forth in one of claims 66 to 71, a main face treating means (90) being provided between said preproduct provision means (Fig. 5) and said preproduct subdividing means (102,112).

73. An apparatus as set forth in claim 72, said main face treating means (90) comprising a powder fog chamber (90), said first conveyor means (68) extending through said powder fog chamber (90).

74. An apparatus as set forth in claim 73, said first conveyor means (68) comprising a powder-permeable preproduct supporting face (72-72) adapted to expose both main faces (64a,64b) of said disc-shaped preproduct (64) to powder fog treatment.

75. An apparatus as set forth in one of claims 66 to 74, said preproduct subdividing means (102,112) comprising a cutting grid (102) and pressure means for (112) urging said disc-shaped preproduct (64) through said cutting grid (102).

76. An apparatus as set forth in claim 75,
 said cutting grid (102) being mounted on a movable
 grid carrier (100), said cutting grid (102) being mov-
 able by said grid carrier (100) through a plurality of
 stations (Stat.I-Stat.VI) including a preproduct inlet
 station (Stat.I) in which said disc-shaped preprod- 5
 uct (64) is positioned on said cutting grid (102), a
 grid entrance station (Stat.II) in which said preprod-
 uct (64) is pressed into cutting cells (116) of said
 cutting grid (102) and a food stuff body ejecting sta- 10
 tion (Stat. IV) in which said food stuff bodies (22)
 are located on said carrier surface (12) of said car-
 rier member (10).
77. An apparatus as set forth in claim 76, 15
 a carrier supply conveyor (132,138) being provided
 for conveying said carrier members (10) from a car-
 rier member supply (136) to said food stuff body
 ejecting station (Stat.IV). 20
78. An apparatus as set forth in claim 77,
 said carrier supply conveyor (132,138) joining said
 second conveyor means (140).
79. An apparatus as set forth in claims 76 to 78, 25
 said plurality of stations (Stat.I-VI) further compris-
 ing a cutting grid treatment station Stat.VI) for
 applying a treatment agent (158) to said cutting
 grid, said treatment agent (158) being hereupon
 transferred from said cutting grid (102) to side faces 30
 (26) of said food stuff bodies (22).
80. An apparatus as set forth in one of claims 76 to 79,
 said plurality of stations (Stat.I-VI) further compris- 35
 ing a grid cleaning station (Stat.V) for cleaning said
 cutting grid (102) by removing cutting residues of
 said food stuff.
81. An apparatus as set forth in one of claims 66 to 80,
 gas filling means (170) being allocated to said 40
 encapsulating station (144) for introducing protec-
 tive gas into said food stuff package (40).
82. An apparatus as set forth in one of claims 66 to 81,
 further comprising a stacking station (Fig. 16) for 45
 stacking a plurality of at least and preferably two
 food stuff packages (40A,40B) and securing said
 stacked food stuff packages (40A,40B) with respect
 to each other. 50

55

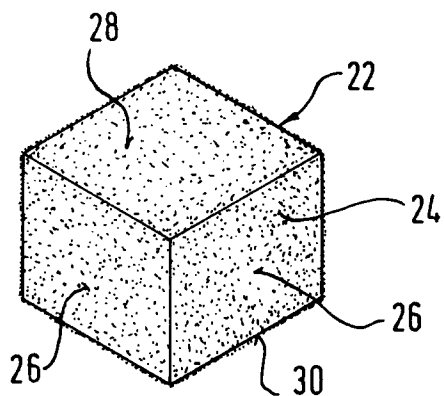
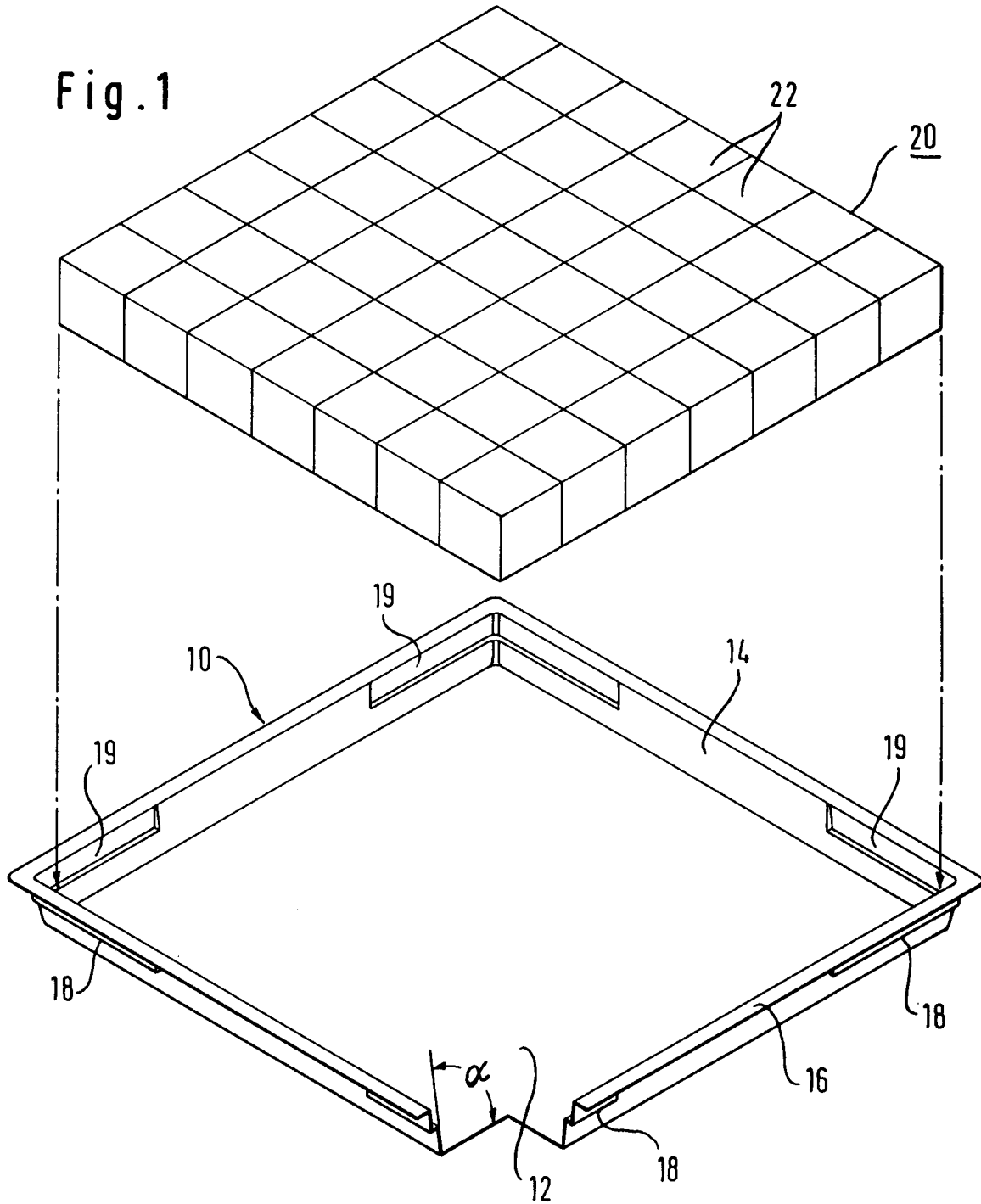

Fig. 3

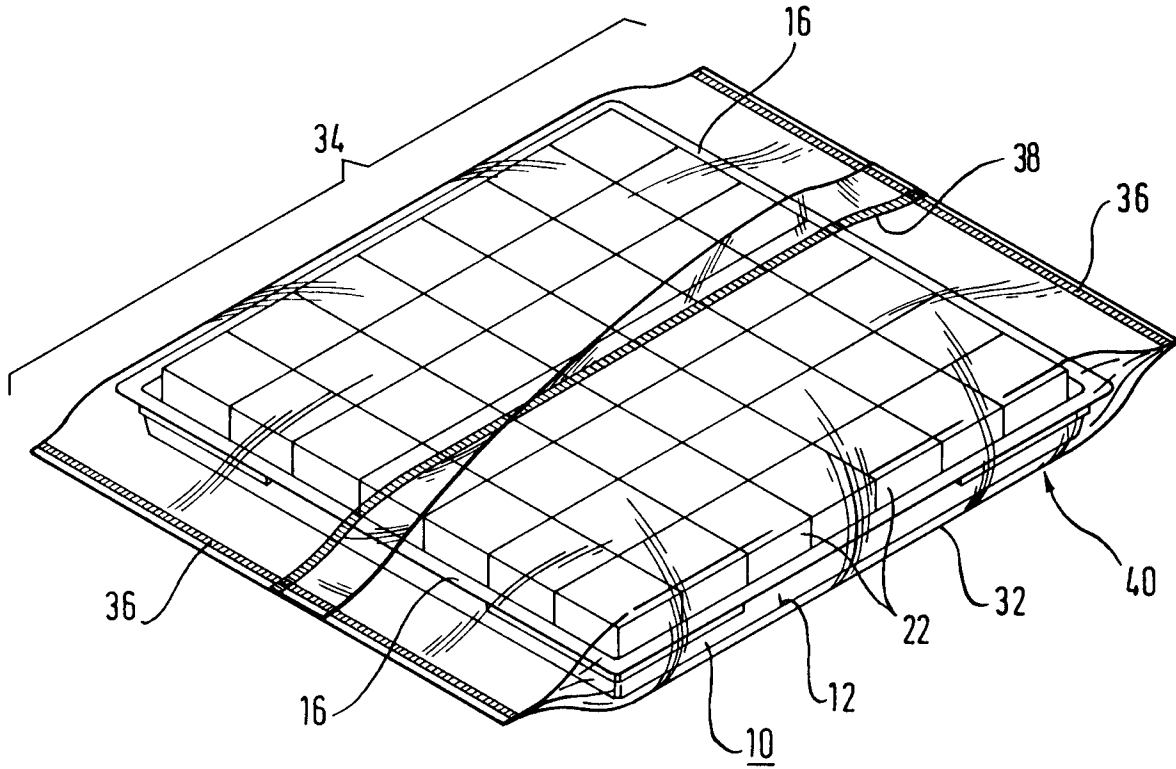

Fig. 4

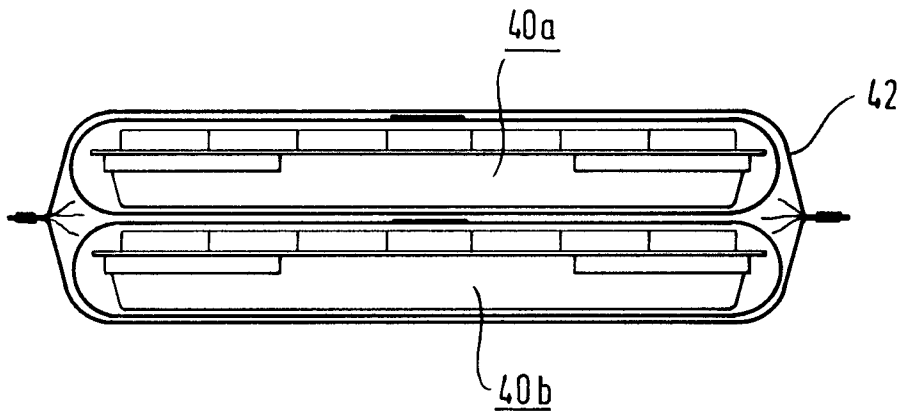

Fig. 5

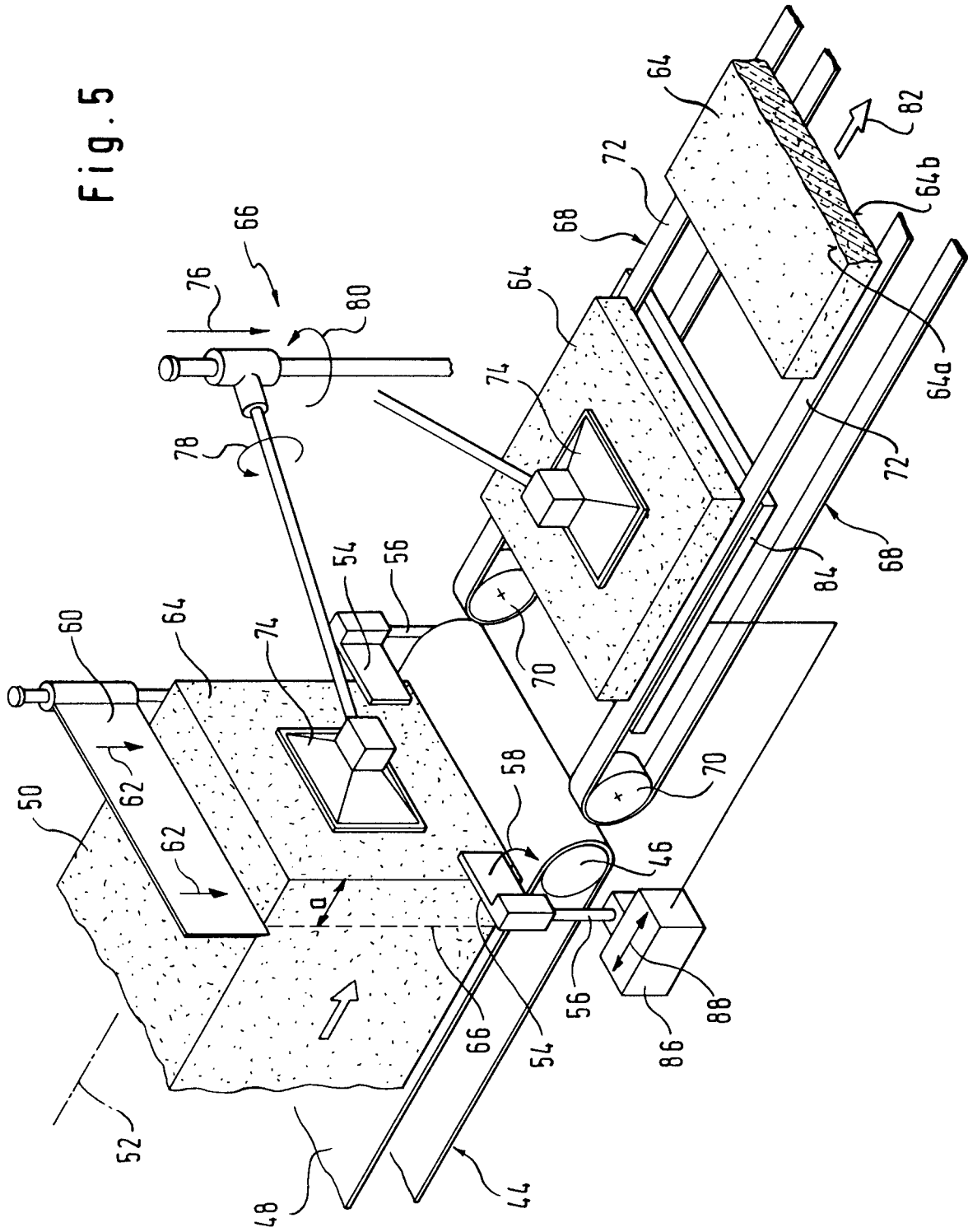

Fig. 6

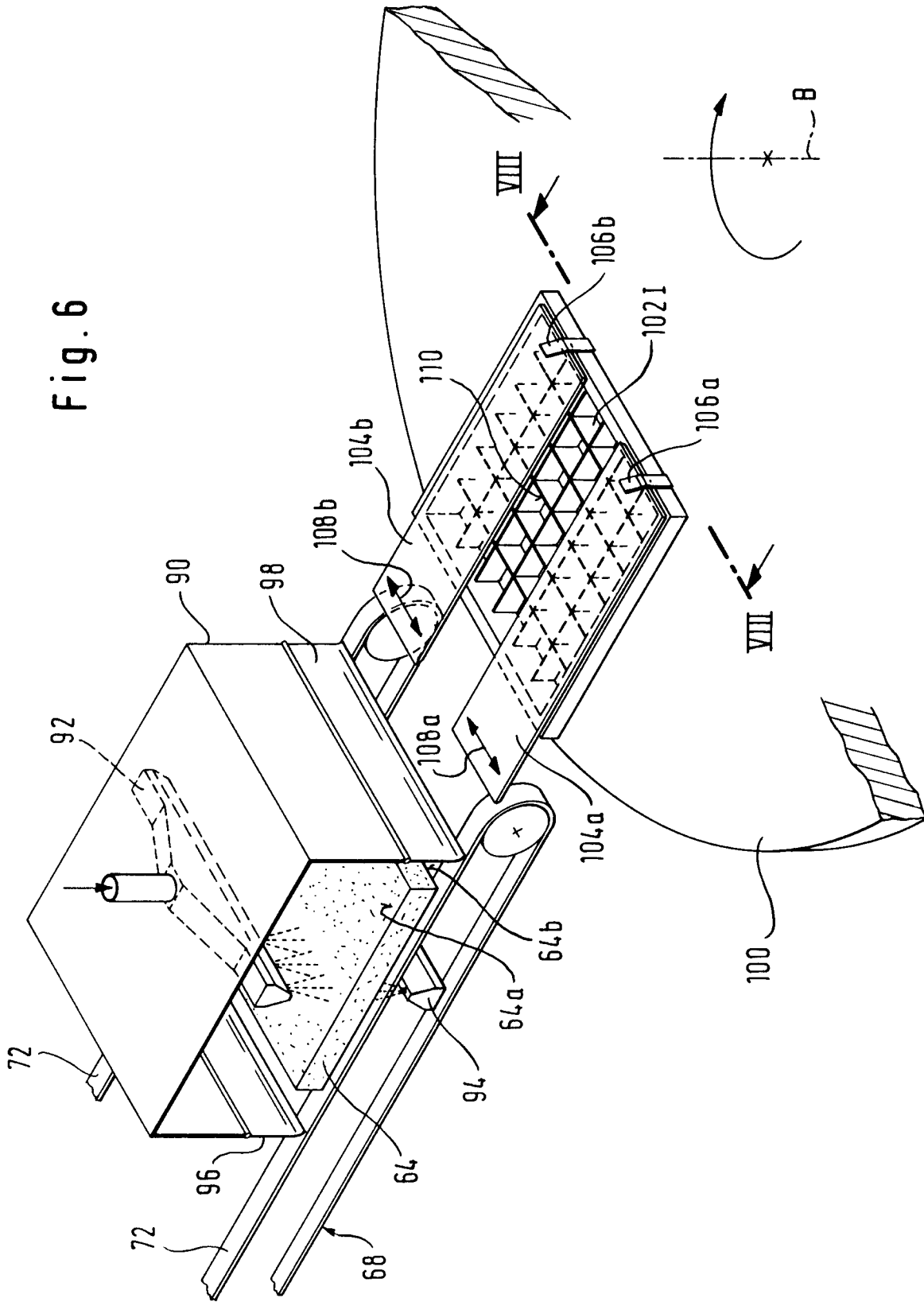

Fig. 8

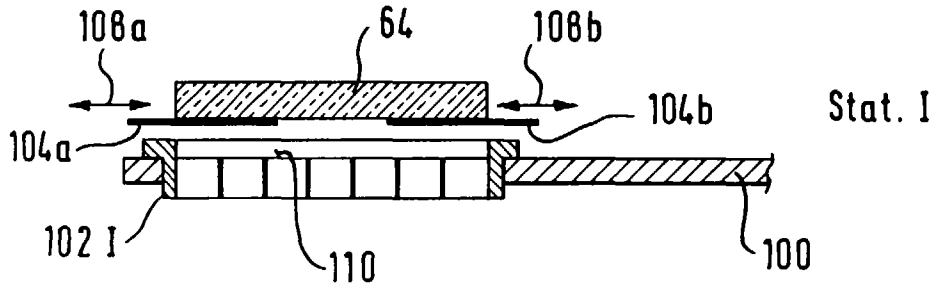

Fig. 9

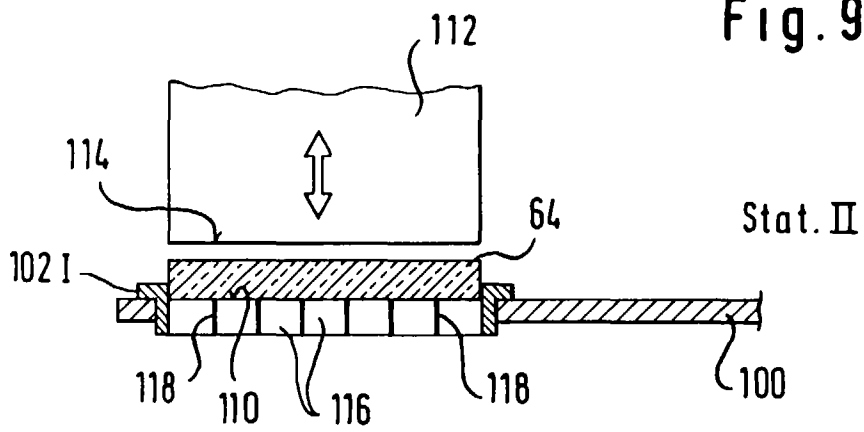
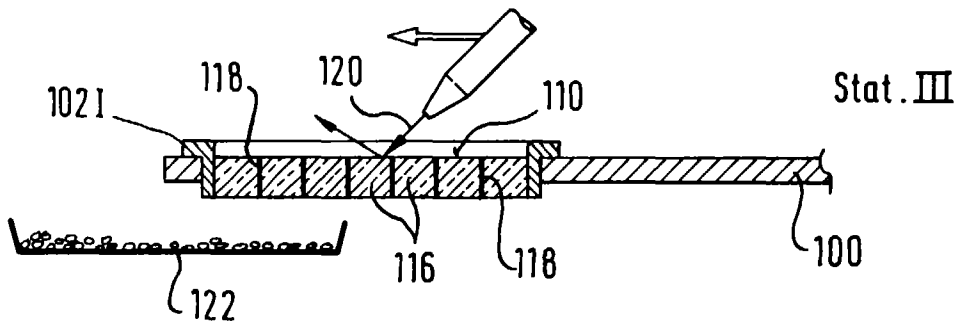
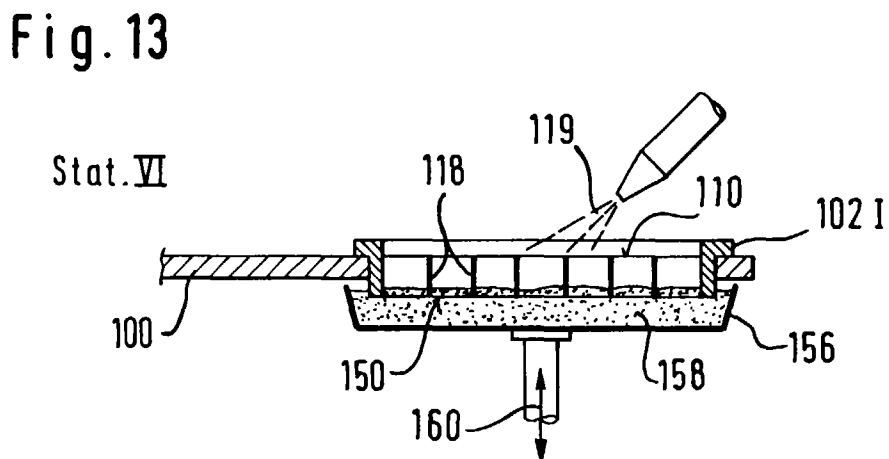
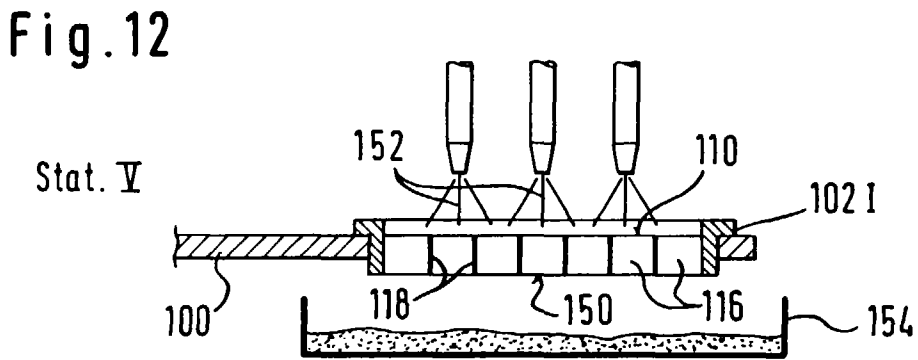
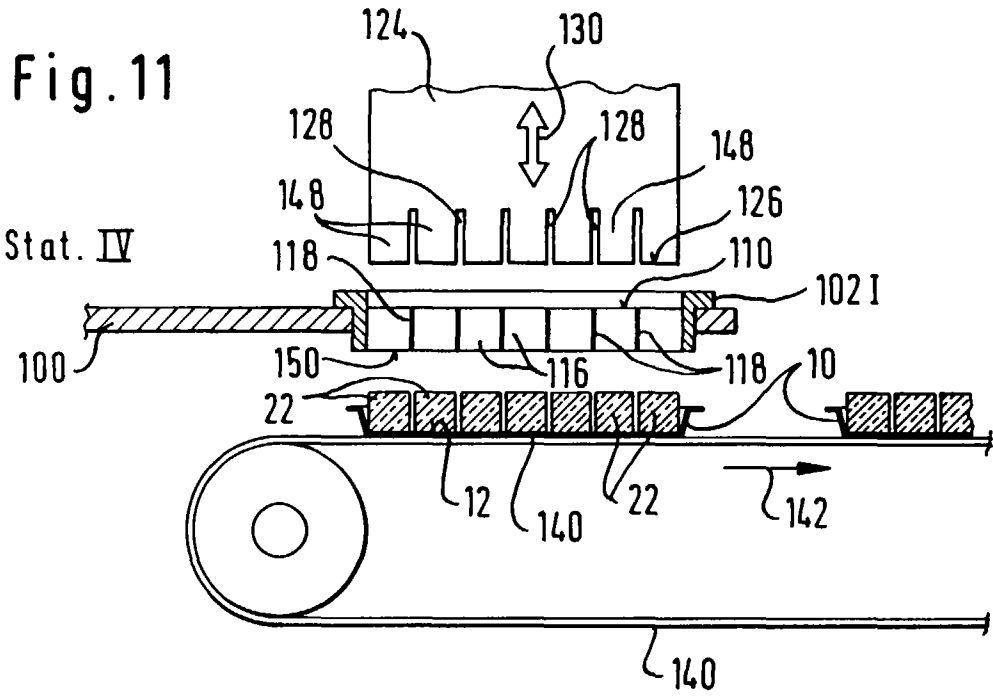

Fig. 10





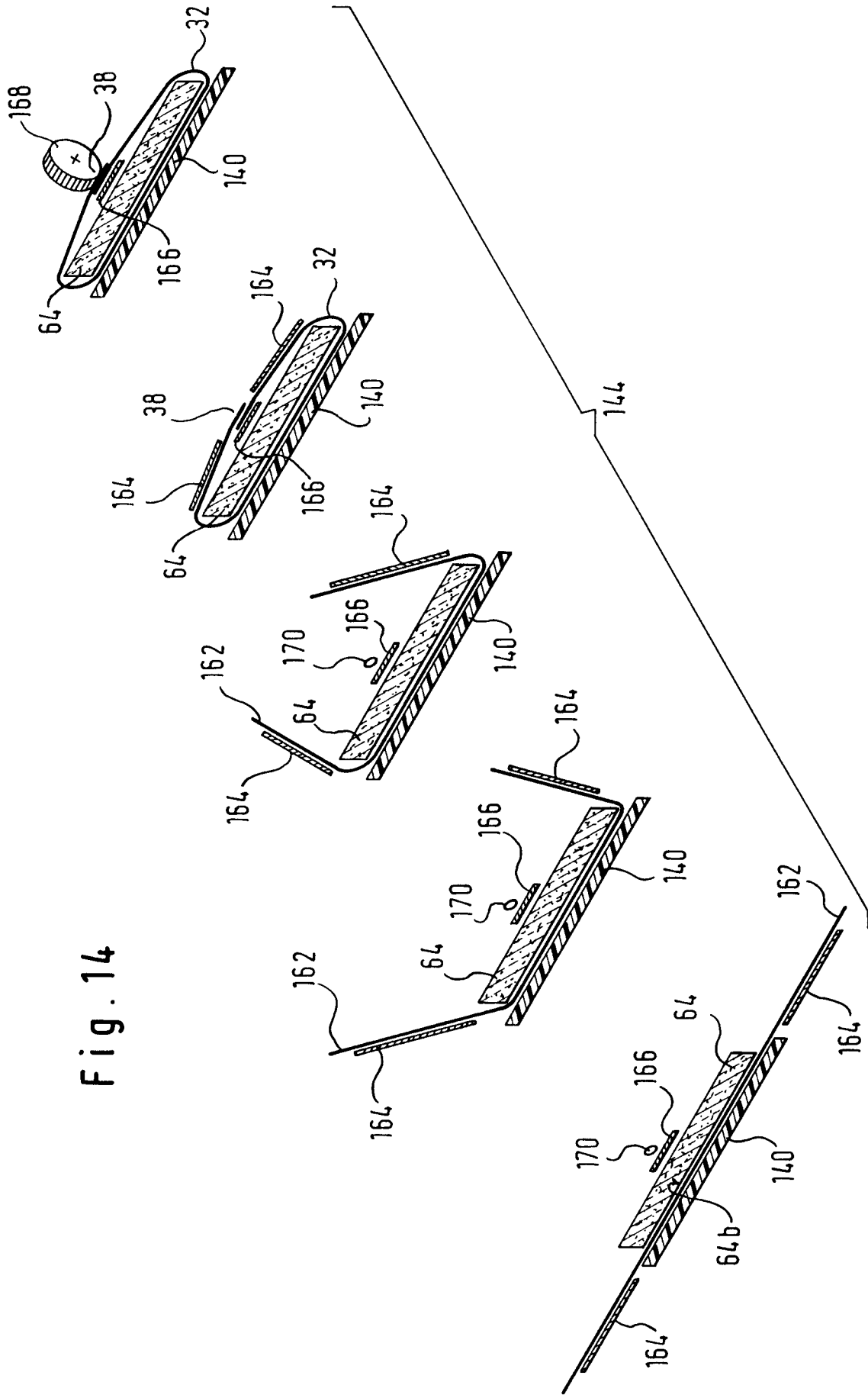

Fig. 14

Fig. 15

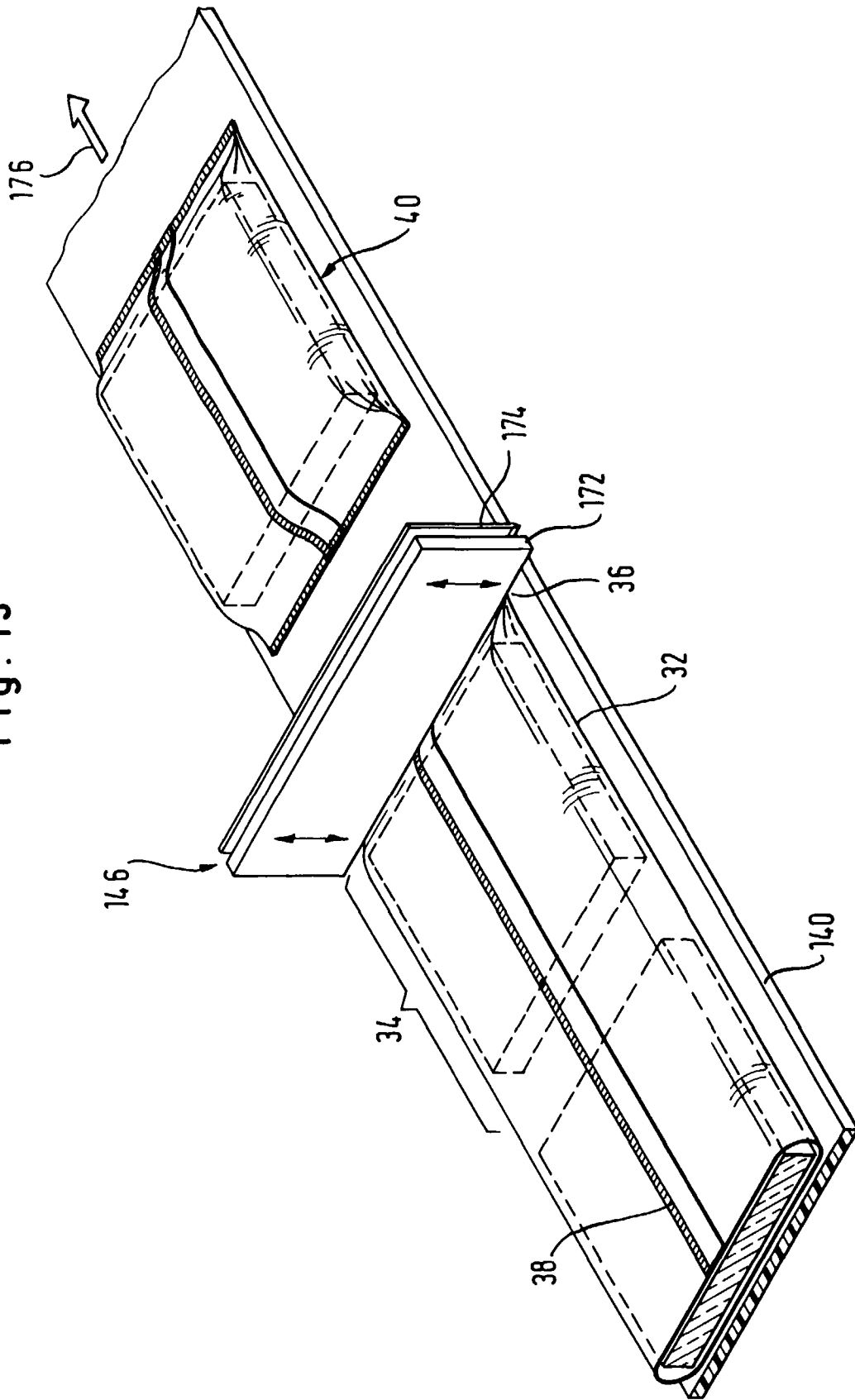
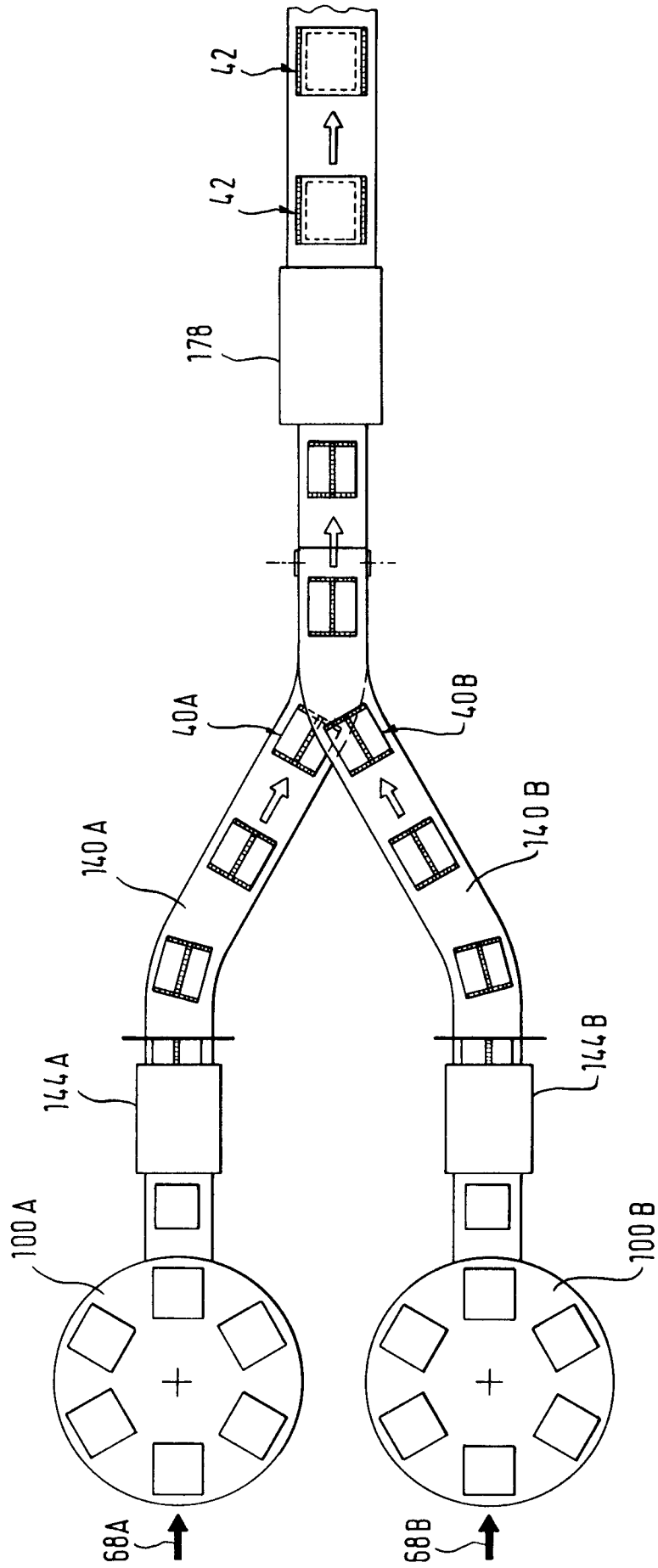

Fig. 16





European Patent
Office

EUROPEAN SEARCH REPORT

Application Number
EP 96 10 9614

DOCUMENTS CONSIDERED TO BE RELEVANT			
Category	Citation of document with indication, where appropriate, of relevant passages	Relevant to claim	CLASSIFICATION OF THE APPLICATION (Int.Cl.6)
X	EP-A-0 375 513 (DUTEIL FRANCE GASTRONOMIE SARL) * the whole document * ---	1-4,11, 16,17, 21-29, 31-33, 37,38	B65B25/06 B65D77/00 B65D85/76 B26D3/18
X	FR-A-2 679 201 (LE GOFF) * the whole document * ---	1-16,21, 22,25, 26,34	
X	FR-A-2 654 707 (FROMAGERIES REYBIER SA) * the whole document * ---	1-4,7, 11,12, 19,25	
A	EP-A-0 237 715 (HOLZ ERNST) * the whole document * ---	41,42, 66,67,75	
A	GB-A-1 578 721 (GRIFFITHS) * the whole document * ---	41,42, 66-68,75	TECHNICAL FIELDS SEARCHED (Int.Cl.6) A01J B26D B65B B65D
A	EP-A-0 028 278 (CODAT MANAGEMENT LTD) * the whole document * -----	41,66	
The present search report has been drawn up for all claims			
Place of search		Date of completion of the search	Examiner
BERLIN		19 November 1996	Béraud, F
CATEGORY OF CITED DOCUMENTS X : particularly relevant if taken alone Y : particularly relevant if combined with another document of the same category A : technological background O : non-written disclosure P : intermediate document T : theory or principle underlying the invention E : earlier patent document, but published on, or after the filing date D : document cited in the application L : document cited for other reasons ----- & : member of the same patent family, corresponding document			

EPO FORM 1503 01.82 (P04C01)