

(19)



Europäisches Patentamt

European Patent Office

Office européen des brevets



(11)

EP 0 813 922 A1

(12)

**EUROPEAN PATENT APPLICATION**

(43) Date of publication:  
29.12.1997 Bulletin 1997/52

(51) Int. Cl.<sup>6</sup>: **B22D 17/14**, B22D 17/20,  
B22D 41/50, B22D 17/30,  
B22D 17/32

(21) Application number: 97109129.3

(22) Date of filing: 06.03.1990

(84) Designated Contracting States:  
AT CH DE ES FR GB IT LI NL SE

(30) Priority: 07.03.1989 US 320140

(62) Document number(s) of the earlier application(s) in  
accordance with Art. 76 EPC:  
90905277.1 / 0 462 218

(71) Applicant:  
ALUMINIUM COMPANY OF AMERICA  
Alcoa Center, PA 15069-0001 (US)

- (72) Inventors:
- Fields, James R.  
Export, PA 15632 (US)
  - Chu, Men Glen  
Export, PA 15632 (US)
  - Cisko, Lawrence W.  
Irwin, PA 15642 (US)
  - Drane, Donald L.  
New Kensington, PA 15068 (US)
  - Eckert, George C.  
Murrysville, PA 15668 (US)
  - Full, George C.  
Murrysville, PA 15668 (US)
  - Hornack, Thomas R.  
Lower Burrell, PA 15068 (US)
  - Kasun, Thomas J.  
Pittsburgh, PA 15239 (US)
  - Klingensmith, Marshall A.  
New Kensington, PA 15068 (US)

- McMichael, Jerri F.  
Pittsburgh, PA 15239 (US)
- Manzini, Richard A.  
Greensburg, PA 15601 (US)
- Miller, Janel M.  
Lower Burrell, PA 15068 (US)
- Pajerski, A. Victor  
Upper Burrell, PA 15068 (US)
- Premkumar, M.K.  
Monroeville, PA 15146 (US)
- Robinson, Robert E.  
Pittsburgh, PA 15239 (US)
- Rodjom, Thomas J.  
Murrysville, PA 15668 (US)
- Scott, Gerald D.  
Massena, NY 13662 (US)
- Truckner, William G.  
Avonmore, PA 15618 (US)
- Wallace, Robert C.  
New Kensington, PA 15068 (US)
- Zaidi, Mohammad A.  
Monroeville, PA 15146 (US)

(74) Representative:  
Baillie, Iain Cameron  
Ladas & Parry,  
Alzheimer Eck 2  
80331 München (DE)

Remarks:  
This application was filed on 05 - 06 - 1997 as a  
divisional application to the application mentioned  
under INID code 62.

**(54) Vacuum die-casting machine and method**

(57) This invention concerns an improved vacuum die-casting machine especially for high pressure die-casting processes. It comprises die machine section (2), fill chamber (10) communicating with said die section, inlet opening (60) adjacent to the fill chamber, piston (4), piston rods (21), piston rod seals (98), pressure control means (108) and enclosure means extending from fill chamber, forming an air tight enclosure behind said piston.

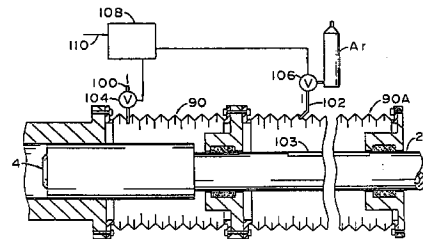

FIG. 6B

EP 0 813 922 A1

## Description

This invention relates to vacuum die-casting machine and method for casting processes, especially high-pressure die-casting processes. The invention has particular application to that branch of the die-casting field where vacuum is used to facilitate the die-casting operation and/or enhance the product.

Morgenstern disclosed a vacuum die-casting machine in U.S. Patent No. 2,864,140.

A vacuum die-casting machine of design similar to that of the Morgenstern machine is described in U.S. Patent No. 4,476,911 assigned to Maschinenfabrik Mueller-Weingarten A.G. of Weingarten, West Germany.

U.S. Patent No. 4,583,579 of Miki et al. relates to the measuring of temperature and calculation of clearance of a plunger, sleeve and spool bush in a die casting machine, in order to control plunger retraction and determine the presence of abnormal operating conditions.

U.S. Patent No. 3,544,355 disclosed a method and apparatus for lubricating a shot cylinder in a die casting machine. Spray head means is adapted to be moved into position for spraying the lubricant directly into the interior of the shot cylinder.

In accordance with the present invention there is provided a vacuum die-casting machine having a die section (2), a fill chamber (10) having a bore communicating at a first end with said die section and with an inlet opening (60) adjacent a second end of said fill chamber, a piston (4) slidable in said bore between a retracted position beyond said inlet opening toward said second end and an extended position toward said first end, said piston (4) having a piston rod (21) extending out of the bore beyond the second end of the fill chamber (10) and pressure control means (108) creating a vacuum in the fill chamber bore in front of the piston with said piston in the retracted position to draw molten metal into the fill chamber bore through said inlet opening, said machine characterized by a piston rod seal (98) engaging said piston rod, enclosure means extending from the second end of said fill chamber (10) to said piston rod seal forming an air-tight enclosure behind said piston, and said pressure control means (108) simultaneously applying a vacuum to said enclosure behind the piston (4) when a vacuum is created in the fill chamber bore in front of the piston.

Also provided in accordance with this invention is a vacuum die-casting machine having a fill chamber (10) with a bore for communicating at a first end with a die (2), a piston (4) extendable in said bore to charge molten metal into the die, a piston rod (21) connected to said piston and extending out of a second end of the fill chamber, and means (90) sealing said second end of said fill chamber characterized by a piston rod seal (98) engaging said piston rod, and enclosure means (94) extending from said fill chamber (10) to said piston rod seal (98) and forming with said piston rod seal an air-tight enclosure at the second end of said fill chamber, said enclosure means (94) being at least laterally flexible to accommodate lateral movement of said piston rod (21) and piston rod seal (98) relative to said fill chamber (10).

Further provided in accordance with the present invention is a method of operating a die casting machine in which a piston (4) which charges molten metal into a die (213) is retracted in a bore in a fill chamber (10) beyond an inlet opening (60) and a vacuum is applied to the fill chamber bore in front of the retracted piston to draw molten metal into the bore of the fill chamber through the inlet opening, said method characterized by applying a vacuum behind said piston during application of vacuum in front of the piston.

Still further provided in accordance with the present invention is a method of vacuum die casting an aluminum alloy containing iron in a die containing iron, said method comprising: applying to at least one of the die (213) and a fill chamber (10) of the die-casting machine, a lubricant comprising a lubricating species which produces a gas when exposed to molten alloy, applying a vacuum to the fill chamber and die to evacuate air and draw molten alloy into the fill chamber, and charging the molten alloy in the fill chamber into the die to form in the die a cast product, said method characterized by said aluminum alloy comprising less than about 0.5% iron, said lubricant being a water-based lubricating fluid comprising water, said lubricating species at a concentration no more than that which results in a gas content of less than about 10 ml/100 g of alloy in said cast product, and a halogenated salt at a concentration sufficient to substantially inhibit soldering of said alloy to said die or fill chamber, and including evaporating the water from the applied lubricating fluid, and tightly sealing said fill chamber to prevent sucking air into said fill chamber when applying said vacuum to the fill chamber and die, and wherein said molten metal is charged from the fill chamber into the die at gate velocities of at least 15 meter per second.

Also provided in accordance with the invention is a vacuum die-casting machine comprising a fill chamber (10) having a bore into which molten metal is drawn by a vacuum, and a piston (4) slidable in said bore of the fill chamber to charge said molten metal into a die on a forward stroke of the piston, and characterized by a thin flexible elongated generally cylindrical skirt seal (140) between said piston and the bore of said fill chamber and having a forward edge secured to said piston and a floating rearward edge, said thin flexible elongated cylindrical skirt seal having a diameter which provides sealing engagement with the bore of the fill chamber.

Also provided in accordance with this invention is a vacuum die-casting process characterized by controlling of piston (4) to fill chamber (10) clearance for the metal feed stroke of the piston.

A die-casting process incorporating this invention involves the following consideration:

### 1. Composition of the material being die cast

2. Melting practice, including degasification and filtration of the melt
3. Supply of the molten material to the die casting machine
4. The fill chamber section
5. Lubricants and coatings for the fill chamber and die
6. The casting, including its cleanup, heat treatment and properties

Considerations involved in each of these topics are as follows:

1. Composition of the material being die cast

While portions of this invention will be applicable to the die casting of any material, for instance magnesium alloys, others will find preferred embodiments in conjunction with certain alloys of aluminum, one especially advantageous example being an aluminum-silicon-magnesium casting alloy (hereinafter referred to as the AlSi10Mg.1 alloy) of the following percentage composition:

Si 9.5-10.5  
 Mg 0.11-0.18  
 Fe 0.4 maximum  
 Sr 0.015-0.030

Other elements may be present, some as impurities, some to serve special purposes. For instance, Ti may be present, for instance in the range 0.05-0.10 percent. B may also be present. For one exemplary alloy, a reasonable limit for such other elements is that they not exceed a total of 0.25 percent. Another choice of limits might be: Others each 0.05% max, others total 0.15% max.

All parts and percentages appearing here and throughout are by weight unless otherwise specified.

In general, the functions of the constituents of the alloy are as follows. The silicon lends fluidity to the melt for facilitating the casting operation, as well as imparting strength to the casting. The strontium provides a rounding of the silicon eutectic particles for enhancing ductility. Magnesium provides hardening during aging based on Mg<sub>2</sub>Si precipitation.

Addition of iron suppresses soldering of the alloy to the iron-based mold and to iron-based conduits or containers on the way to the mold. Soldering leads to sticking of the cast part to the die surface, roughening of dies and of the walls of die casting machine fill chambers, to breakdown of sealing, to wear of the pistons of die-casting machines, and to surface roughening on the castings matching the surface roughening of the dies.

Soldering is particularly a problem in the casting of die castings, which have high gate velocities relative to other casting techniques. Die-castings, in general, have a metal velocity through the gate in the range 15 to 70 meters/sec (50 to 200 feet/sec). High gate velocities may be necessary for a number of reasons. For instance, thin gates are of advantage and desired for mass-produced die castings, because it is then easy simply to break the gate material away from the casting during trimming. Unfortunately, thin gates (maximum thickness  $\cong$  about 2 millimeters) necessitate high metal flow velocities through them, and higher metal pressures and temperatures, particularly in the casting of complexly shaped parts, and these conditions have all been found to promote soldering. Another reason for high gate velocities can be the need to get complete filling of a mold for making a thin-walled casting, e.g. castings containing walls of thickness  $\cong$  5 mm.

The commonly used countermeasure against soldering is increased iron content, up to 1, or even 1.3, % iron.

The iron compositional range for compositions preferred for use is low compared to the usual iron level used for high-gate-velocity die castings. This represents an important aspect i.e. the discovery of ways to die-cast lower-iron, non-ferrous, e.g. light metal, or aluminum, high-gate-velocity die castings. Thus, to the extent iron is present, it can have a deleterious effect on ductility of the alloy and on the ability of cast parts to withstand crush tests. As a basic rule of thumb, the lower the iron content can be kept, the better for purposes of high elongation and crush resistance. The ability to achieve high-gate-velocity die-casting production runs of commercially acceptable duration, for low-iron aluminum casting alloys, makes even more attractive the idea of vehicle manufacture based on aluminum structures, for example, the joints of an automotive space-frame such as disclosed in U.S. Patent No. 4,618,163.

In contrast, low-gate-velocity, thick-gate castings may be die-cast without too much worry of causing soldering. Of course, then the gates have to be sawed off rather than broken off. Iron contents in the 0.3-0.4% range are used in low-gate-velocity die casting, and iron may even be as low as 0.15%.

Given that some iron must be present if for instance, iron-based dies are to be used, and especially in the case of high-gate-velocity die casting, it can be of advantage to add to the above composition certain elements which will alter the effect of the iron on mechanical properties. For instance, an element may be added for affecting morphology of the plate-shaped iron-bearing particles from a platelet shape to a more spheroidized shape, in order to maintain ductility at higher Fe levels. Elements which are considered as candidates for altering the effect of iron are Ni, Co, Be, B, Mn, and

Cr at levels about in the range 0.05 to 0.1, 0.2, or even 0.25 percent.

As indicated at the beginning of this section, other compositions can be used. For instance, iron may be varied in the range beginning at 0.5% downwards, and, in some instances, iron may be as low as 0.2%, perhaps even down to 0.1%. Silicon may be decreased to around 8%. And, magnesium may be brought down to 0.10%. Thus, an alternate, composition may be:

Si	7.5 - 8.5
Mg	0.08 - 0.12
Fe	0.15 - 0.25
Sr	0.015 - 0.25
Remainder Al.	

For certain applications, the present invention can as well be applied to the die-casting of the class of aluminum alloys containing 7-11% magnesium.

Alloy products which can be casted in varying embodiments are: 356, 357, 369.1, 409.2, and 413.2, as listed in the Registration Record of Aluminum Association Alloy Designations and Chemical Composition Limits for Aluminum Alloys in the Form of Castings and Ingots, published by the Aluminum Association, Washington, D.C..

## 2. Melting practice, including degasification and filtration of the melt

Material (such as the AlSi10Mg.1 alloy described above) of the correct composition is melted, adjusted in composition as required, and then held for feed to a die-casting machine as needed.

Adjustment of composition comprises three parts: Removal of dissolved gas, addition of alloying agents, and removal of solid inclusions.

In the case of aluminum alloy, for example, it is important for a number of reasons, such as the obtaining of excellent mechanical properties, avoidance of blistering during heat treatment, and good welding characteristics, that the molten metal be treated for removal of dissolved hydrogen. There are different ways of doing this, such as vacuum melting, reaction with chlorine bubbled into the melt, or physical removal by bubbling an inert gas, such as argon, through the melt. Chlorine additionally removes sodium and produces a dry skim of aluminum oxide, the dryness being of advantage for good removal of the skim, in order to avoid solid inclusions in the castings. A skim which is wet by the molten aluminum is more difficult to remove.

Modifying agent, e.g. strontium, sodium, calcium or antimony, addition for modifying the shape of silicon phase may be added, for instance, in the form of master alloy wire of composition 3-4% Sr, balance essentially aluminum, to a trough where the melt is flowing from a melting furnace where melting and hydrogen removal was performed to a holding furnace where the melt is stored preparatory to casting. Because chlorine reacts with Sr, it is beneficial to bubble inert gas, such as argon, for example, through the melt following the fluxing with chlorine, in order to remove chlorine as much as possible before the Sr addition.

Master alloy wire of composition 3.5% Sr, balance aluminum, has been found to be more effective for this modification of the silicon in the eutectic than master alloy wire of composition 9% Sr, balance aluminum.

There is an incubation period needed following addition of Sr. Until the incubation period has been passed through, silicon morphology modification is insufficient. There is also a point in time after which the melt becomes stale, in that the action of the Sr is no longer effective for silicon shape modification. When this point arrives, casting is discontinued. At a molten metal temperature of 715 to 760°C (1320 to 1400°F) the incubation period can amount to about 5 minutes for a 3.5% Sr master alloy and about 1 hour for a 9% Sr master alloy. At a holding temperature of 760°C (1320°F), there will be a residence time of e.g. 6 to 7 hours during which silicon modification is satisfactory; following such residence time, the melt becomes stale and is no longer effective for silicon modification. The residence time of a satisfactory silicon modification is greater than at 732°C (1350°F) than at 760°C (1400°F).

Strontium content is preferably in the range of about 0.01 to 0.03% in the molten metal and in the casting for effective silicon modification.

Solid inclusions not eliminated by skim removal in the melting ladle are removed by filtration, for example through ceramic foam or particulate filters. This may be carried out as the melt moves from the trough into the container in the holding furnace. In the case of metal, e.g. aluminum alloy, castings, particularly die castings, it is advantageous to limit inclusions to for example  $12 \leq$  one  $20\text{-}\mu$  inclusion per cc of metal in the casting and, preferably  $\leq$  one  $15\text{-}\mu$ , or even  $\leq$  one  $10\text{-}\mu$  inclusion per cc of metal. Filter pore and/or grit size is chosen to meet the chosen standard. The desired flow rate through the filter is then obtained by appropriate filter area and pressure head. The inclusion content of the metal is determined by metallographic examination of a statistically adequate sample removed from the area of the holding furnace from which the metal brought into the die casting machine is taken. The sample is obtained using equipment as described, for instance, by R. D. Blackburn et al. in papers presented at the Pacific Northwest Metals and Minerals Conference, April 27, 1979, and involves the sucking of a statistically adequate quantity of metal through a filter and

analyzing the inclusions retained on the filter. In the 20- $\mu$  test for instance, the number of such inclusions found is divided by the quantity of metal sucked through the filter; the presence of inclusions of size greater than 20- $\mu$  means the metal fails the test.

### 5 3. Supply of the molten material to the die casting machine

Molten material is brought from the holding furnace to the die casting machine through a suction tube. The suction tube preferably extends into a region of the holding furnace container where, as melts is removed for casting, melt pressure head causes melt replenishment to move through a filter into such region. The suction tube extends from the holding furnace to a fill, or charging, chamber, also called a shot sleeve, at a hole in the fill chamber referred to as the inlet orifice.

The suction tube is preferably made of graphite (coated for protection against oxidation on its outer surface) or ceramic, for preventing iron contamination of the melt and for facilitating suction tube maintenance.

15 A ceramic, e.g. boron nitride, inlet orifice insert may be used to reduce heat transfer, thus guarding against metal freezing in the inlet orifice, and to reduce erosion at that location. This may be coupled with a ceramic insert in the shot sleeve in the area of the inlet orifice, also to prevent erosion. Erosion may be handled, as well, with an H-13-type steel replacement liner at such location.

An electric inlet orifice heater also may be used to guard against metal freezing at the inlet orifice. This so-called pancake heater operates in the manner described below.

20 A moat in the fill chamber outside wall, in the portion of the outside wall surrounding the inlet orifice, may also be used for reducing heat transfer out of the area of the inlet orifice.

A secondary, crushable, die-formed (by ribbon compression) graphite-fiber seal at the inlet orifice outside of primary seals may be used to guard against air leakage at the primary seals into the melt at the junction between the suction tube and the shot sleeve.

### 25 4. The fill chamber section

Several important aspects of the die-casting process involve the fill, or charging, chamber, or shot sleeve of the die-casting machine. For instance, the fill chamber seats a piston, or ram, which is preferably made of beryllium copper. The piston serves for driving melt from the fill chamber to the die, or mold. Additionally associated with this section of the die-casting machine are means for applying coatings or lubricants to occupy the interfaces between the fill chamber and piston and between the fill chamber and the melt.

#### a. The piston

35 Several features of the fill chamber section contribute particularly to high quality die castings. As regards the piston, one important aspect involves protection from its being a source of harmful gases, for instance air from the environment, leaking into the molten material contained under vacuum in the fill chamber. The piston must be able to execute its different functions of first containing and then moving the melt to the die. It must be movable and yet sealed as much as possible against the encroachment of contamination into melt contained in the fill chamber.

40 Advantageous features provided for the piston include 1) aspects of sealing, 2) a joint between the piston and the piston rod, and 3) measures taken to control temperature to stabilize the sliding fit between the fill chamber bore and the piston exterior.

45 According to a preferred mode of sealing around the piston, the seal extends between the fill chamber and the piston rod. This feature assures sealing for as long as desired during piston travel.

In a further development of the sealing of the piston a flexible envelope between the fill chamber and the piston rod accommodates different alignments of the piston and rod. This arrangement also prevents damage to sealing gaskets by aluminum solder or flash which is generated by movement of the piston.

50 In another embodiment, the piston includes a flexible skirt for fitting against variations in the bore of the fill chamber, in order to better seal the piston-fill chamber bore interface against gas leakage into melt in the fill chamber.

A swivel, or ball, joint, or articulation, between the piston and the piston rod may also be provided to allow the piston to follow the bore of the fill chamber.

The piston is cooled, this assisting, for instance, in freezing the so-called biscuit against which it rams in the final filling of the die.

55 Temperature, particularly temperature differences between the piston and the fill chamber bore, is controlled, to resist contamination of the melt by gas leaking through the interface between piston and bore. Measures used include direct monitoring and controlling of piston temperature, which in turn permits control of cooling fluid flow to the piston based on timing or cooling fluid temperature.

## b. The fill chamber itself

The fill chamber itself like the die, may be made of H13 steel, which preferably has been given a nitride coating using the ion-nitriding technique.

The fill chamber may optionally have ceramic lining for providing decreased erosion, reduced release agent (lubricant) application or reduced heat loss. While the disclosure is presented mainly in the context of so-called "cold chamber" technology, i.e. die machine temperatures such that the metal from the holding furnace is basically losing heat as it moves to the die, the use of "hot chamber" technology, where the fill chamber, for instance, has about, the same temperature as the molten metal, will act to guard ceramic liners against spalling and other degradation due to temperature gradients. For instance, linear 20 of Fig. 1 in U.S. Patent No. 2,671,936 of Sundwick can be provided in ceramic form, together with substitution of other parts of his molten metal supply equipment toward the goal of providing a hot chamber die caster resistant to attack by the metal being cast, particularly aluminum alloy. Ceramic liners provide compositional choices not subject to the aluminum-iron interaction and can, therefore, stay smooth longer, this being of advantage, for instance, for preventing wear in the flexible skirt.

The fill chamber section additionally includes means for applying and maintaining vacuum. Vacuum is achieved by adequate pumping and, even more importantly, it is maintained by attention to sufficient sealing. In general, it is poor practice to increase pumping and not give enough attention to the seals. Insufficient sealing will mean larger amounts of gas sweeping through the evacuated fill chamber and a concomitant risk of melt contamination. Vacuum quality may be monitored by pressure readings (vacuum levels are kept at 40 to 60 mm Hg absolute, preferably less than 50 mm absolute, down to even less than 25 mm Hg absolute) and additionally by measures such as gas tracing, for instance argon and/or helium tracing, and gas mass flow-metering, under either feedback or operator control.

## c. Means for applying coatings or lubricants

An important aspect of the fill chamber section involves the application of coatings or lubricants. Measures such as ion nitriding are done once and serve for making many castings. Other coatings and lubricants are applied of often, for instance before the forming of each casting.

Coatings and lubricants may be applied manually, using nozzles fed by the opening of a valve. Or, they may be applied by use of so-called "rider tubes" which ride with the piston to lubricate the bore of the fill chamber. Rider tubes typically involve the use of a non-productive piston stroke between each die feeding stroke for lubricating the fill chamber bore preparatory for the next filling of melt into the fill chamber. Another option for lubrication is the "drop oiler" method, where oil is placed on the sides of the, piston when it is exposed, for subsequent distribution to the bore of the fill chamber during piston stroke.

According to one especially advantageous embodiment, a fill chamber "die-end" lubricator is provided. It is called a "die-end" lubricator, because it accesses the fill chamber bore from the end of the fill chamber nearest the die, when the die halves are open. The die-end lubricator eliminates the non-productive stroke. Other important advantages of the die-end lubricator are uniform, thorough application of coatings and lubricants, the drying of the water and/or alcohol component of water and/or alcohol-based coatings and lubricants, and the sweeping, or evacuation, of solder, or flash, and evaporated water and/or alcohol from the fill chamber bore by pressurized gas blow.

5. Lubricants and coatings for fill chamber and die

The lubricants and coatings used in the fill chamber and die have been found to be especially advantageous for enabling high pressure die casting of parts in low iron, precipitation hardenable aluminum alloy. The die castings have low gas content and can be heat treated to states of combined high yield strength and high crush resistance.

Both fill chamber bore and the cast-metal-receiving faces of the die are preferably given a nitride coating using the ion-nitriding technique. Ion nitriding, also known as plasma nitriding, is a commonly utilized surface treatment in die casting. Ion nitriding is used in conventional die casting mainly to reduce die wear caused by high velocity erosion. This surface treatment of the fill chamber bore and the die, preferably in combination with the use of lubricant, especially the halogen salt-containing lubricant has been found to be particularly effective for inhibiting soldering in the high pressure die casting of low iron, precipitation hardenable aluminum alloy.

Lubrication is important for long and successful runs which avoid soldering, i.e. attack of the steel fill chamber and die walls by aluminum alloy melt. Thus, while die and sleeve lubricants for the most part have very different functions, both lubricants have the common function that they must minimize the soldering salt reaction.

In one embodiment a halogenated of an alkali metal is added to die and fill chamber lubricants to achieve a marked reduction in soldering, particularly in the case of die-casting low-iron aluminum silicon alloys. For instance, potassium iodide added to lubricant (2 to 7% in sleeve lubricant and 0.5 to 3% in die lubricant) inhibits the formation of solder buildup and enables a reduction in the lubricating species, for instance organic, required for performance. The lubricating species in the water-based lubricants to which it is added (emulsion, water soluble synthetic, dispersion or, suspen-

sion) only serve to provide the friction reduction required for part release on the die and heat transfer reduction in the sleeve. An example of lubricating species is polyethylene glycol at 1% in the water base. Graphite is another lubricating species, which may be added to facilitate release of the castings from the die.

Lubricants containing halogenated salt of alkali metal provide an overall reduction in gas content in the cast parts.

5 An important step in the reduction of the gas content in these castings has been the development of the herein described die-end lubricator equipment to apply lubricant to the fill chamber bore. This equipment enables the use of water and/or alcohol based lubricants for the bore. Thus, the die-end lubricator has brought consistency to the lubricant application and provides the ability to apply inorganic materials, such as potassium iodide. Importantly, steam generated by the evaporation of the water is removed from the sleeve by the sweeping action of the drying air emitted from  
10 its nozzle.

6. The casting, including its cleanup and heat treatment and properties

15 Upon removal of the casting from the die, the casting may be allowed to cool to room temperature and sand blasted, if desired, for removing surface-trapped lubricant, to reduce gas effects during subsequent treatment, for instance to reduce blistering during subsequent heat treatment and outgassing during welding. The sand blasting can also remove surface microcracks on die casting this leading to improved mechanical properties in the die castings, particularly improved crush resistance.

Heat treatment of die castings of the AlSi10Mg.1 aluminum alloy, for instance, is designed to improve both ductility  
20 and strength. Heat treatment comprises a solution heat treatment and an aging treatment.

Solution treatment is carried out in the range 482 to 510°C (900 to 950°F) for a time sufficient to provide a silicon coarsening giving the desired ductility and to provide magnesium phase dissolution. The lower end of this range has been found to give desired results with much reduced tendency for blistering to occur. Blistering is a function of flow stress and the lower temperature treatment (which are associated with lower flow stress) therefore helps guard against  
25 blistering. The lower end of the range also provides greater control over silicon coarsening, the coarsening rate being appreciably lower at the lower temperatures.

Aging, or precipitation hardening, follows the solution heat treatment. Aging is carried out at temperatures lower than those used for solution and precipitates Mg<sub>2</sub>Si for strengthening. The concept of the aging integrator, as set forth in U.S. Patent No. 3,645,804, may be employed for determining appropriate combinations of times and temperatures  
30 for aging. Should the casting be later subjected to paint-bake elevated temperature treatments, the aging integrator may be applied to ascertain the effect of those treatments on the strength of the finished part.

This solution plus aging treatment has been found to permit the selection of combined high ductility and high strength, the ductility coming from the solution treatment, the strength coming from the aging treatment, such that a wide range of crush resistance, for instance in box-shaped castings, can be achieved.

35 As noted above, it is preferred that solution heat treatment temperatures at the lower end of the solution heat treatment temperature range be used. Time at solution heat treatment temperature has an effect. The yield strength obtainable by aging decreases as time at solution heat treatment temperature increases. Achievable yield strength falls more quickly with time at solution heat treatment temperature for the higher solution heat treatment temperatures, for instance 510°C (950°F), than is the case for lower solution heat treatment temperatures, for instance 493°C (920°F).  
40 Achievable yield strength starts out higher in the case of solution heat treatment at 510°C (950°F) but falls below that achievable by solution heat treatment at 493°C (920°F) as time at solution heat treatment temperature increases.

Casting properties following heat treatment of the above-referenced AlSi10Mg.1 alloy are as follows:

- 45 Yield strength in tension (0.2% offset) ≥ 110 MPa  
(Yield strength being typically 120-135 Mpa)
- Elongation ≥ 10% (typically 15-20%)
- Free bend test deformation ≥ 25 mm even ≥ 30 mm
- Total gas level ≤ 5 ml/10g metal
- Weldability = A or B
- 50 Corrosion resistance ≥ EB
- Yield strength and elongation determined according to ASTM Method B557.

Free bend test deformation is determined using a test setup as shown in Fig. 15. The radii on the heads, against which the specimen deflects, measure 1.27 cm (0.5 inch). The specimen, measuring 2 mm thick by 7.62 cm (3 inch)  
55 long by 1.52 cm (0.6 inch) wide, is given a slight bend, such that the specimen will buckle as shown when the loading heads are moved toward one another. For specimens thicker than 2 mm, they are milled, on one side only, down to 2 mm thickness, and bent such that the outside of the bend is on the unmilled side. The top and bottom loading beads close at a constant controlled stroke rate of 50 mm/min. Recorded as "free bend test deformation" is the number of millimeters of head travel which has occurred when specimen cracking begins. Free bend test deformation is a measure

of crush resistance.

Mechanical properties e.g. yield strength and free bend test, are determined with specimens cut from the walls of complex castings, as contrasted with the practice of the direct casting of test specimens which are essentially ready for testing as cast.

5 Gas level is determined by metal fusion gas analysis of the total casting, including mass spectrographic analysis of the constituents. Typically, gas level is below 5 ml, standard temperature and pressure (STP), i.e. 1.033 Kg/cm<sup>2</sup> (1 atmosphere pressure) and 240°C (75°F), per 100g metal. The practice of melting the total casting is to be contrasted with the possibility of testing individual portions cut from a casting. Melting the total casting provides a good measure of the real quality being attained by the casting equipment and process.

10 Weldability is determined by observation of weld pool bubbling, using an A, B, C scale; A is assigned for no visible gassing, B for a light amount of outgassing, a light sparkling effect, but still weldable, and C for large amounts of outgassing and explosions of hydrogen, making the casting non-weldable. Alternatively, gas level is a measure of weldability, weldability being inversely proportional to gas level.

Corrosion resistance is determined by the EXCO test, ASTM Standard G34-72.

15 Representative of the quality of high-gate-velocity, precipitation-hardened die castings of the invention on AlSi10Mg.1 alloy are the following results of mechanical testing on die castings obtained from two runs:

Run No.	0.2% Yield Strength, MPa			Free Bend Test Deformation, mm		
	Max.	Ave.	Min.	Min.	Ave.	Max.
3-5Q	141	130	120	37	42	44
3-5R	139	129	125	39	42	46

Fig. 1 shows a side view, partially in section, of a die-casting machines.

Fig. 2 shows a cast piece from the die in Fig. 1.

Fig. 3 is a schematic representation of melting practiced.

30 Fig. 4 is an elevational, cross-sectional, detail view of one embodiment of the region around the fill chamber end of the suction tube in Fig. 1.

Fig. 5 is an elevational, cross-sectional, detail view of a second embodiment of the region around the fill chamber end of the suction tube in Fig. 1.

35 Fig. 5A is schematic, perspective view of a third embodiment of the region around the fill chamber end of the suction tube in Fig. 1.

Fig. 6 is an elevational, cross-sectional, detail view of a seal for sealing the piston-fill chamber interface.

Figs. 6A and 6B are views as in Fig. 6 of modifications of the seal.

Fig. 7 is an axial cross section of a second embodiment of a piston.

Fig. 8 is an axial cross section of a third embodiment of a piston.

40 Fig. 9 is a cross sectional, plan, schematic view of the die-casting machine as seen using a horizontal cutting plane in Fig. 1 containing the axis of the fill chamber 10.

Fig. 10 is a view as in Fig. 9, showing more detail and a subsequent stage of operation.

Fig. 11 is a view based on cutting plane XI-XI of Fig. 10. Fig. 12 is a view based on cutting plane XII-XII of Fig. 10.

Fig. 13 is a view based on cutting plane XIII-XIII of Fig. 10.

45 Fig. 14 is a view based on cutting plane XIV-XIV of Fig. 13.

Fig. 15 is an elevational view of the test setup for measuring free bend test deformation.

Fig. 16 is an oblique view of a casting.

Fig. 17A is a schematic, partially cross-sectioned, view of an internally cooled piston-in a heated fill chamber bore.

Figs. 17B to 17D are control diagrams.

50 Discussion of the art is divided into the following sections:

- a. A die casting machine in general
- b. Melting equipment
- c. Inlet orifice
- 55 d. Sealing fill chamber to piston rod
- e. Alternative pistons
- f. Die-end lubricator
- g. Controlling the piston to fill chamber clearance
- h. Example

These sections are as follows:

a. A die casting machine in general

5 Referring to Fig. 1, this figure shows, in the context of a cold chamber, horizontal, self-loading, vacuum die casting machine, essentially only the region of the fixed-clamping plate 1, or platen, with the fixed die, or mold, half 2 and the movable clamping plate 3, or platen, with the movable die, or mold, half 5 of the die casting machine, together with the piston 4, suction tube 6 for molten metal supply, holding furnace 8, and fill chamber 10.

10 The vacuum line 11, for removing air and other gases in the direction of the arrow, is connected to the die in the area where the die is last filled by incoming molten metal. Line 11 is opened and shut using valve 12, which may be operated via control line 13 by control equipment (not shown).

15 Fig. 2 shows an example of an untrimmed die-cast piece, for example in the form of a hat, with the gate region 14 separating the hat portion 15 from the sprue 16 and biscuit 17. The vacuum connection appears as appendage 18. Desirably, gate region 14 is thin, e.g.  $\leq 2$  mm thick, such that it can be broken away from the cast part. Also the vacuum appendage is sized for easy removal.

20 Referring again to Fig. 1, a conical, or spherical, projection 4a is provided at the frontal face of the piston 4. The rear of the piston is connected to piston rod 21. The rear region 10a of the fill chamber 10 shows a sealing device 90, which is explained in detail below in the discussion of Fig. 6. The suction tube 6 is connected to the fill chamber 10 by means of a clamp 22. This clamp 22 has a lower hook-shaped, forked tongue 24 which passes underneath an annular flange 25 on the suction tube 6. From the top, a screw 26 is threaded through the clamp 22. This enables a clamping of the end of suction tube 6 to the inlet orifice of the fill chamber 10.

25 Die end lubricator 170 is used to apply lubricant to the bore of fill chamber 10 from the die end of the fill chamber, when the movable die and platen, plus ejector die (not shown) have separated from the fixed die and platen. Reference may be had to Fig. 9 for added information concerning this lubricator.

30 Operation of the die casting machine of Fig. 1 generally involves a first two phases, and a subsequent, third phase can be included. In Phase 1, vacuum is applied to evacuate the die and fill chamber and to suck the metal needed for the casting from the holding furnace into the fill chamber. Phase 1 further includes movement of the piston at a relatively slow speed for moving the molten charge toward the die cavity. Phase 2, which is marked by a high velocity movement of the piston for injecting the molten metal into the die cavity, is initiated at, or somewhat before, the time when the metal reaches the gate where the metal enters into the cavity where the final part is formed. Phase 3 involves increased piston pressure on the biscuit; piston movement has essentially stopped in Phase 3.

Further details of the various aspects of the machinery shown in Fig. 1 will be explained below.

b. Melting equipment

35 Fig. 3 illustrates an example of melting equipment used for providing a suitable supply of molten alloy, for instance AlSi10Mg.1, for die casting.

40 Solid metal is melted in melting furnace 40 and fluxed, for example using a 15 minute flow of argon + 3% by volume chlorine from the tanks 42 and 44, followed by a 15 minute flow of just argon. A volume flow rate and gas distribution system suitable for the volume of molten metal is used.

As needed to make up for metal cast, metal is caused to flow from melting furnace 40 into trough 46, where strontium addition is effected from master alloy wire 48.

45 The metal flowing from the trough is filtered through an inlet filter 50 as it enters the holding furnace 8 and subsequently through an exit filter 54, before being drawn through suction tube 6. Alternatively, filter 50 may be provided in a separate unit within the holding furnace 8. The filter pore sizes can be the same or different. For instance, inlet filter 50 can be a coarse-pored ceramic foam filter and exit filter 54 a fine-pored particulate filter. Alternatively, both filters can be fine-pored particulate filters. The filter pore sizes are chosen to provide the above-specified metal quality with respect to inclusion content in the castings. Filter 54 could be placed on the bottom of tube 6 and subcompartment 56 eliminated, but the structure as shown is advantageous in that it permits the use of a larger expanse of fine-pored filter 54 this making it easier to assure adequate supply of clean molten metal for casting.

c. Inlet orifice

50 Fig. 4 shows details of an embodiment of the inlet orifice 60 in fill chamber 10. Three important aspects of this embodiment are guarding against 1) metal freezing onto the walls of the inlet orifice, 2) erosion of the walls of the inlet orifice by the molten metal flow, and 3) loss of vacuum within the fill chamber.

A boron nitride insert 62 contributes particularly to aspects 1 and 2.

Primary seals 64 and 66 contribute particularly to aspect 3, sealing the inlet orifice at seating ring 68, nipple 70, and ceramic liner 72.

Heat is fed into nipple 70 by heating coil 71, for instance an electrically resistive or inductive heating coil.

Crushable, graphite-fiber seal 74 squeezed between fill chamber 10 and nipple 70 guards against air leakage at the primary seals.

5 Pancake heater 80 is formed of a grooved ring 82. The groove carries an electrical resistance heating coil 84. The heater is held against plane 86, which is a flat surface, machined on the exterior of exterior surface of the fill chamber. Steel bands 88 encircle the fill chamber to hold the heater in place.

Flange 25 is provided, in order that clamp 22 of Fig. 1 may hold the end of the suction tube tightly sealed against the fill chamber 10.

10 Fig. 5 shows details of a second embodiment of the inlet orifice 60 in fill chamber 10. This embodiment illustrates the use of an air-filled moat 76 surrounding the inlet orifice. Alternatively, the moat 76 can be filled with an insulating material other than air. The moat mitigates the heat-sink action of the walls of the fill chamber, in order to counteract a tendency of melt to freeze and block the inlet orifice.

The embodiment of Fig. 5 also illustrates the idea of a ceramic, or replaceable steel liner 78 for the bore of the fill chamber.

15 Structural details in Fig. 5 which are the same or essentially similar to those in the embodiment of Fig. 4 have been given the same numerals used in Fig. 4.

It will be evident from the discussions of Figs. 4 and 5 that a main theme there is maintaining a sufficiently high temperature at the inlet orifice. Fig. 5A illustrates an embodiment caring for this concern of temperature maintenance in a unique way. According to this embodiment, the suction tube 6 is relatively short, compared to its length in the embodiments of Figs. 4 and 5, and the reservoir 130 of molten metal is brought up near to the inlet orifice 60 such that heat transfer from the molten metal in the reservoir keeps the inlet orifice 60 clear of solidified metal. The reservoir is provided in the form of a trough, through which molten metal circulates in a loop as indicated by the arrows. Pumping and heat makeup is effected at station 132. All containers may be covered (not shown) and holes provided for access, for instance for suction tube 6. Metal makeup for the loop comes from the coarse filter 50 of Fig. 3, and the fine filter 54, is provided as shown, in order to effect a continuous filtering, of the recirculating metal.

#### d. Sealing fill chamber to piston rod

30 Fig. 6 illustrates several features, one feature in particular being an especially advantageous seal for sealing the piston-fill chamber interface against environmental air and dirt.

In Fig. 6, there is shown piston 4 seated in fill chamber 10 at the fill chamber end farthest from the die. Inlet orifice 60 appears in the drawing. It will be evident that the piston as shown in Fig. 6 is in the same, retracted, or rear, position in which it sits in Fig. 1. Rather than, or in addition to, packing which might be provided at the interface between chamber 10 and piston 4, the embodiment of Fig. 6 provides a seal 90 extending between the fill chamber 10 and the piston rod 21.

Proceeding from the fill chamber, seal 90 comprises several elements. First, there is a fill chamber connecting ring 92 bolted to the fill chamber. A gasket (not shown) occupies the interface between ring 92 and the fill chamber, for assuring gas tightness, despite any surface irregularities between the two.

40 Hermetically welded between ring 92 and a follower connecting ring 93 is flexible, air-tight envelope 94. As illustrated, envelope 94 is provided in the form of a bellows. Ring 93 in turn is bolted, also with interposition of a gasket, to piston rod follower 96. An air-tight packing 98 lies between follower 96 and rod 21.

Also forming a part of seal 90 are a line 100 from envelope 94 to a source of vacuum, a line 102 to a source of argon, and associated valves 104, 106, controlled on lines, as shown, by programmable controller 108, to which are input on line 110 signals indicating the various states of the die casting machine.

45 Seal 90 operates as follows. Follower 96 rides on rod 21 as the piston executes its movement in the bore of fill chamber 10 to and from the die. Either from influences such as banana-like curvature of the bore of fill chamber 10 or due to flexing of the piston rod under the loading of its drive (not shown), and even as influenced by possible articulation of the piston to the piston rod (as provided in embodiments described below), there can be a tendency for the piston rod to want to rotate about axes perpendicular to it. Because of the flexible envelope, these rotational tendencies are easily permitted to occur without adverse effect on the sealing provided by packing 98. The follower simply moves up and down in Fig. 6, or into or out of Fig. 6, to follow the piston rod in whatever way it might deviate from the axes of the piston and fill chamber bore.

55 With respect to controller 108, it serves the following function. When the piston is in the retracted position as shown, controller 108 holds valve 104 open and valve 106 closed. Vacuum reigns both in the bore of the fill chamber and within envelope 94. The required amount of molten metal enters the bore through inlet orifice 60, whereupon piston rod 21 is driven to move piston 4 forwards toward the die. The supplying of molten metal is terminated as the piston moves into position to close the inlet orifice. If the piston were to move further toward the die such that it would move beyond the inlet orifice and open it to the interior of envelope 94 while the interior were still under vacuum, molten metal would be drawn through the inlet orifice into the interior of the envelope and there solidify, to ruin the envelope. The programma-

ble controller prevents this by using the information on machine state from line 110 to close valve 104 and open valve 106. Argon fills envelope 94 to remove the vacuum and prevent melt from being sucked through inlet orifice 60.

The presence of argon in the system is utilized for monitoring effectiveness of seals. Helium is an alternative gas which may be used in this way. For instance, the tightness of the sliding fit between fill chamber bore and piston may be monitored and/or controlled. Helium sensors in the vacuum lines connected to the die and fill chamber and a knowledge of where helium has been introduced allow tracing and determination of the piston to fill chamber seal. Metal fusion gas analysis utilizing mass spectrometer technology allows detection of argon in a casting, and, with acknowledge of where argon was present during the casting process, information can be gathered on the tightness of the intervening seals.

In an alternative embodiment shown in Fig. 6A, line 102 is replaced or augmented by one or more longitudinal slots 103 on the outer diameter of piston rod 21. An alternative or supplement of the effect of slots may be achieved by a reduction in the diameter of the rod. Use of the reduction in diameter is advantageous as compared to the slot, because the edges of the slot can cut the packing, unless they are rounded off. The slots or reduction are placed such that, just as piston 4 is about to clear inlet orifice 60, whereupon molten metal would be sucked into envelope 94, the slots open a bypass of the seal provided by packing 98. The bypass provided by slots 103 opens to the air of the environment.

In the alternative of Fig. 6B, the slots 103 open to the interior of basically a duplicate 90A of the structural items 92, 93, 96, 90 containing argon essentially at atmospheric pressure on the basis of line 102 and valve 106. Pressures somewhat above atmospheric pressure may be used, for instance if argon replenishment through line 102, as the volume gets bigger due to the access provided by slots 103, is not rapid enough to otherwise maintain the necessary pressure to drop, and keep, the metal level below the inlet orifice 60. The flexible envelope 94 of the duplicate and the length of slots 103 are sufficiently long that argon can feed into cylinder 10 right through to the stopping of the piston against the biscuit. The duplicate of 92 is connected to the follower 96 of the structure of Fig. 6. The envelope of this duplicate structure is also chosen sufficiently long that the slot 103 does not open the argon chamber (which it provides) to outside air when the piston is in its retracted position, i.e. in its position as shown in Fig. 6B.

Other features of Fig. 6 include a supplementary seal 112 on follower 96. The piston presses against seal 112 when the piston is in its retracted position.

Also shown in Fig. 6 are the concentric supply and return lines 114, 116 for cooling fluid (for instance, water and ethylene glycol) to the piston. Thermocouples (not shown) in the fill chamber walls, piston metal-contact and bore-contact walls (the leads of these thermocouples are threaded back through the cooling fluid lines), and in the water stream are used or open or closed loop stabilizing of the sliding, fit between fill chamber bore and piston. Other factors, such as force needed to move the piston (this being a measure of the friction between bore and piston), or the amount of argon appearing in the vacuum lines connected to die and fill chamber, may as well be used in monitoring and control schemes for stabilizing the sliding fit to minimize gas leakage through the interface between piston and bore.

Another feature is illustrated in Fig. 6. The back edge of the piston has been provided with a flash, or solder reaction product, remover 118. This remover is made of a harder material which will retain the sharpness of its edge 120 better than the basic piston material which is selected on the basis of other design criteria, such as high heat conductivity. On the piston retraction stroke, remover 118 operates to scrape, or cut, loose flash or solder left during the forward, metal feeding stroke of the piston. Attention is given to keeping the forward edge 122 sharp too, but, as indicated, this is an easier task in the case of remover 118.

#### e. Alternative pistons

Fig. 7 shows a second embodiment of a piston. This piston, numbered 4' to indicate the intent that it serve as a replacement for piston 4, includes a flexible skirt 140 for fitting against variations in the bore of the fill chamber.

Skirt 140 is made, for instance, of the same material as the piston itself. It is flexible in that it is thin compared to the rest of the piston and it is long. Its thickness may be, for example 0.038 cm (0.015 inch) all of which stands out beyond the rest of the piston; i.e. outer diameter of the skirt is e.g. 0.076 cm (0.030 inch) greater than the outer diameter of the rest of the piston. Preferably, the skirt has an outer diameter about 0.0025 cm (0.001 inch) greater than the inner diameter of the bore of fill chamber 10; i.e. there is nominally a slight interference fit is the skirt with the bore. The flexibility of the skirt avoids any binding.

It will be understood that skirt 140 is relatively weak in compression. In order that solder buildup, or flash, not collapse the skirt on the rearwards stroke of the piston, the skirt includes a hem 142. The inner diameter of hem 142 is less than that of a neighboring shelf 144 on the body of the piston. Should the skirt encounter any major resistance on the rearward piston stroke that would otherwise compressively load the skirt, the hem transfers such loading to the body of the piston and thus protects the skirt from any danger of collapse.

Threading at 146 and 148 is used for assembling the piston. Holes 150 provide for use of a spanner wrench.

Before assembly, metal spinning techniques may be used to provide an outward bulging of the thin portion of skirt 140. Metal spinning involves rotating the skirt at high speed about its cylindrical axis and bringing a forming tool, for instance a piece of hardwood, into contact with the interior of the thin portion of skirt 140, to expand the diameter outward. While this acts to increase the nominal interference with the fill chamber bore, the thinness of the material pre-

vents binding of the piston in the bore This added bulging increases the sealing effect of the skirt.

Fig. 8 shows a third embodiment of a piston. This piston 4" provides some features in addition to those shown for piston 4' in Fig. 7. For instance, piston 4" includes a ball-, or swivel-, joint articulation 160 of the piston rod to the piston. This includes a spherical-segment cap 162 welded in place along circular junction 164 to assure containment of cooling fluid.

The hem and shelf facing surfaces in Fig. 8 are machined as conical surfaces in Fig. 8 for providing improved reception as the skirt deflects up to approximately 0.90° maximum rotation, as indicated at A in the drawing.

Assembly of piston 4" is carried out as follows. The socket of the ball joint is supplied by piston face 266 and piston side wall 268, which are joined by threads 269. Shim, or spacer, 270 controls, by its thickness, the amount by which the threads engage, in order to provide proper fit between the ball and the socket. Tightening of the threaded engagement is obtained by applying a clamp wrench to the outer diameter of face portion 266 and a spanner wrench to the slots 272 cut longitudinally into the rear of side wall 268.

Collar 274 is next threaded onto the tail 276 of the ball, using a spanner wrench in holes 278. The ball is prevented from turning relative to the collar by insertion of the hexagonal handle of an Allen wrench inserted into its bore 280 also of hexagonal cross section.

Next in the assembly is placement of the skirt 282 into threaded engagement with side wall 268, using threads 284.

Piston rod 285, with flash remover ring 286 in place, is threaded into engagement collar 274. Annular recess 288 in the bore of the collar assures that there is a tight engagement between tail 276 and piston rod 285. O-ring 290 seals against leakage of coolant fluid.

#### f. Die-end lubricator

Fig. 9 shows a general view of the die-end lubricator 170. It is attached to the fixed clamping plate 31 and can be rotated by hydraulic or pneumatic cylinder 172 into the operative position shown by the dot-dashed representation when the die halves have been opened. In the operative position, a head in the form of nozzle 174 is ready to be run into the fill chamber bore to execute its applicator, drying, and sweeping functions.

Fig. 10 shows the die-end lubricator in greater detail. Programmable controller 108 has already received information from the die-casting machine via line 110 that the machine is in the appropriate state (i.e. the die halves are open and the last casting has been ejected) and has interacted with the fluid pressure unit 176 via line 178 to cause the hydraulic cylinder to move the lubricator into its operative position.

Additionally, the controller has subsequently instructed servo-motor 180 on line 182 to drive timing belt 184, thereby turning pulley 186 and the arm 188 rigidly connected to the pulley, in order that the nozzle 174 has moved into the bore of fill chamber 10.

Interconnection of nozzle 174 to arm 188 involves e.g. a length of flexible tubing 190 which carries four tubes 192, hereinafter referenced specifically 192a, 192b, 192c and 192d, which serve various purposes to be explained.

Nozzle 174 carries a polytetrafluoroethylene (PTFE) collar 194 to guide it in the bore of the fill chamber 10. The collar has a generally polygonal cross section, for example the square cross section shown in Fig. 11, and it only contacts the bore at the polygonal corners, thus leaving gaps 196 for purposes which will become apparent from what follows.

Fig. 12 shows that the flexible conduit 190 is constrained to move in a circular path by channel 198 containing PTFE tracks 200, 201, 202, as it is driven by arm 188. Fig. 12 also shows the four tubes which will now be specified. Tubes 192a and b are feed and return lines for e.g. water-based lubricant or coating supply to nozzle 174. Tube 192c is the nozzle air supply, and tube 192d is a pneumatic power supply line for a valve 204 (Fig. 13) in nozzle 174. The tubes 192 extend between nozzle 174, through the conduit 190, to their starting points at location 206 inwards toward the pivot point for arm 188. At location 206, flexible tubing (not shown) is connected onto the tubes 192, the flexible tubing extending to air and lubricant supply vessels (not shown).

Fig. 13 shows greater detail for the nozzle 174 of the die-end lubricator. Nozzle head 208, which is circular as viewed in the direction of arrow B, has a sufficient number of spray orifices 210 distributed around its circumference that it provides an essentially continuous conical sheet of backwardly directed spray. An example for a nozzle head diameter of 5.71 cm (2.25 inch) is 18 evenly spaced orifices each having a bore diameter of 0.061 cm (0.024 inch). Angle C is preferably about 40°. Angles from 30° to 50°, preferably in the range 35 to 45°.

The nozzle mixing chamber 212 receives e.g. water-based lubricant or coating from tube 214 and air from tube 216, or just air from tube 216, depending on whether valve 204 has opened or closed tube 214 as directed by pneumatic line 192d.

The nozzle 174 is joined to the flexible tubing at junction 218. Line 192c, goes straight through to tube 216. Lines 192a and b are short-circuited at the junction, in order to provide for a continual recirculating of lubricant or coating, this being helpful for preventing settling of suspensions or emulsions. The short-circuiting 220 is shown in Fig. 14. Tube 214 is continually open to the short-circuit, but only draws from that point as directed by valve 204, at which time controller 108 causes a solenoid valve (not shown) in the return line to close, in order to achieve maximum feed of lubricant or

coating to the nozzle.

Programmable controller 108 of Fig. 10 interacts with the pneumatic pressure supply for line 192c to send air to open valve 204, such that a lubricant or coating aerosol is sprayed onto the bore of the fill chamber as the nozzle moves toward the die in the bore. The controller does not operate the servo-motor to drive the nozzle so far that it would spray lubricant down the inlet orifice 60. The nozzle is stopped short of that point, but sufficient aerosol is expressed in the region that part of the bore at the inlet orifice does get adequately coated. The controller additionally provides the ability to vary nozzle speed along the bore, in order to give trouble points more coating should such be desired.

Once the nozzle has gone as far as it should go, just short of the inlet orifice, it is then retracted. During retraction, the controller has caused pneumatic valve 204 to turn the lubricant coating supply off, so that only air from line 192c, tube 216, exits through the orifices 210. This air dries water from water-based lubricant, coating, on the bore, and sweeps it, in gasified form, together with loose solder, or flash, from the bore. When the nozzle is back in its retracted position, as shown by the dot-dashed representation in Fig. 9, controller 108 then operates cylinder 172 to swing the lubricator back out of the way, the die halves are closed, and the die-casting machine is ready to make the next casting.

The gaps 196 allow space such that the gas flow out of the nozzle can escape at the die end of the fill chamber.

#### g. Controlling the piston fill chamber clearance

This invention departs from the work of Miki et al. described in the above-mentioned patent 4,563,579 ('579) by focussing on the fit between piston and fill chamber during the metal feed stroke of the piston as a source of gas in castings made in vacuum die casting machines.

As is evident from Fig. 5 of '579 and the discussion in the text of that patent, the prior practice has involved considerable upward deviation of the temperature of the piston, or plunger, relative to the temperature of the fill chamber bore, i.e. the sleeve, as the piston moves through the metal feed stroke for injecting molten metal into the die. Thus, with reference to Fig. 5 of '579, from a point in time at which the temperatures of piston and fill chamber bore are approximately the same, the temperature of the bore rises to a peak and then falls, while the piston temperature rises to a much higher peak, thence to fall with the bore temperature back to a state where the temperatures are approximately equal. As noted in '579 the relative temperature rise of the piston as compared to the bore can cause the two to attain an interference fit, such that retraction of the piston is delayed until cooling releases the interference fit.

The fit between the piston and bore during the feed stroke of the piston is controlled for resisting gas leakage through the piston-bore interface into the metal which is being forced while under vacuum by the piston into the die. Different measures may be taken to achieve this control. One measure is to regulate the cooling of the piston such that the temperature swing of the piston over the course of a casting cycle is lessened. Thus, while a locked interference fit cannot be accepted, the cooling may be regulated to maintain the piston temperature such that a sliding, gas-leakage minimizing fit is achieved, rather than a looser, gas-admitting fit.

A second measure, which may be used in conjunction with the first measure, includes providing an interference or an otherwise close or sliding fit of the piston in the fill chamber bore at some reference temperature, for instance room temperature, and heating the fill chamber to make the piston movable with tight fit in the fill chamber bore. With the fill chamber being heated, the piston temperature will swing less upward relative to the bore temperature and a tighter, gas-resisting fit can be maintained during the metal feed stroke.

Both measures can be adapted depending on the particular materials of construction, and thus, for instance, on the coefficients of thermal expansion characterizing the materials. The underlying basis for adaptation is the concept of keeping the clearance between piston and fill chamber bore gas-tight during the feed stroke of the piston, balanced with requirements for the force needed to move the piston and control of wear of piston and fill chamber bore.

Figs. 17A to 17D illustrate control of the piston to fill chamber clearance. Piston 4 is internally cooled or heated by water or other fluid entering through supply line 114 and return line 116. Provision is made for continual flow of water through a by-pass line 300 containing a manually operable valve 302 and a check-valve 304. Controller 306 operates an on-off, or variable-position (for use in the case of proportional, proportional-integral, PID, etc., control), valve 308, based on its program and information received from thermocouple 310, whose leads may be threaded out of lines 114 or 116 to the controller. Optionally, a heater or cooler 312 is provided on the fill chamber 10 and controlled from the controller 306 using thermocouple 314.

Figs. 17B to 17D are examples of different control schemes which may be used for controlling piston temperature. In general, it is preferred to control the piston to fill chamber clearance by way of interactions with the piston, since it responds quicker than the fill chamber, due to its copper material and its smaller size.

With reference to Fig. 17B, the control may be a closed-loop control using piston temperature information from thermocouple 310. Illustrated is an on-off control with hysteresis. The operator selects the piston temperature set point  $T_{sp}$ , as well as the temperature deviations  $\Delta 2$  and  $\Delta 1$  which together sum to determine the differential gap. In a variation on the control according to Fig. 17B, a closed-loop control based on piston outlet water temperature is used, there thus being a set point for the water temperature. Piston outlet water temperature is the feedback signal.

Figs. 17c and 17d illustrate open-loop control with variable pulse widths  $\tau_1$  and  $\tau_2$  input by the operator. The time

point 320 is vacuum start or Phase 2 start, Phase 2 being the portion of the piston metal feed stroke where a higher piston travel speed is used, once the metal has reached, or is about to reach, the gate(s) into the portion of the mold cavity where the actual part will be formed. The time point 322 is vacuum end.

5 h. Example.

Further illustrative is the following example:

Example I

10

A complex casting illustrating the invention had the configuration as shown in Fig. 16. For sake of a name, it is referred to as the hat casting. It is composed of a 100 mm section 330 of 5 mm wall thickness and a 200 mm section 332 of 2 mm wall thickness. The casting has a height 334 and depth 336 both of 120 mm. The main gate 342 measured 4 mm x 60 mm in cross section and the two lateral gates 344 each had cross sections of 2 mm x 10 mm. The casting  
 15 was produced as the 32nd casting of a 95 casting run in a vacuum die casting machine as shown in Fig. 1 using the following parameters: Cycle time 0.0 minutes, vacuum during Phase 1 of about 20 mm Hg abs., piston diameter of 70 mm, Phase 1 piston velocity of about 325 mm/sec, Phase 2 piston velocity of about 1785 mm/sec, Phase 3 metal pressure of 868 Dyne/cm<sup>2</sup> (12,580 psig (868 bar)), 141 ml of 1% KI lubricant on the die faces, 7.6 ml of 5% KI lubricant on the fill chamber bore, and metal temperature in holding furnace of 1310°F. Holding furnace metal analysis was 10.1%  
 20 Si, 0.3% Fe, 0.13% Mg, 0.03% Sr, 0.052% Ti. The die casting machine included the bellows-seal of Fig. 6 and the die-end lubricator of Figs. 9-14. The entire casting, trimmed, however, of overflow 338 and gate to biscuit section 340, was tested for gas content by melting of the total part and gave the following results, in milliliters of gas (standard temperature and pressure) per 100 grams of aluminum alloy: 1.29 hydrogen, 1.66 nitrogen, 0.74 nitrogen, 0.72 others, total 4.4  
 25 = 0.5 ml/100g. Mechanical properties for the run, obtained by cutting test specimens from the 2-mm wall thickness portion of several castings after heat treatment of the castings by 1 hour at 765°C (950°F) quench into 57°C (100°F) 40% aqueous solution of Ucon-A, polyglycol product of Union Carbide, followed by 1 hour at 307°C (400°F) were:

25

	Yield Strength MPa	Ultimate Strength MPa	Elongation %	Free Bend mm
Avg	115	195	15.3	37
Min	110	187	9.5	33
Max	121	201	22.0	39

30

35

Claims

1. A vacuum die-casting machine having a die section (2), a fill chamber (10) having a bore communicating at a first end with said die section and with an inlet opening (60) adjacent a second end of said fill chamber, a piston (4) slidable in said bore between a retracted position beyond said inlet opening toward said second end and an extended position toward said first end, said piston (4) having a piston rod (21) extending out of the bore beyond the second end of the fill chamber (10) and pressure control means (108) creating a vacuum in the fill chamber bore in front of the piston with said piston in the retracted position to draw molten metal into the fill chamber bore through said inlet opening, said machine characterized by a piston rod seal (98) engaging said piston rod, enclosure means extending from the second end of said fill chamber (10) to said piston rod seal forming an air-tight enclosure behind said piston, and said pressure control means (108) simultaneously applying a vacuum to said enclosure behind the piston (4) when a vacuum is created in the fill chamber bore in front of the piston.
2. The die-casting machine of claim 1, further characterized in that said pressure control means (108) includes means (106) to replace the vacuum within the enclosure (96) behind said piston (4) with a gas at about ambient pressure as said piston moves toward said extended position and before said piston clears said inlet opening (60).
3. The die-casting machine of claim 2, further characterized in that said pressure control means includes a valving section (103) on said piston rod (21) having a reduced cross-sectional area which is aligned with said piston rod seal (98) to adjust pressure within said enclosure to about ambient pressure as said piston (4) is extended and before said piston clears said inlet opening (60).
4. The die-casting machine of either claim 2 or claim 3, further characterized in that said means (106), to replace the vacuum in said enclosure with a gas at about ambient pressure, comprises means introducing an inert gas into said

40

45

50

55

closure at about ambient pressure.

- 5
- 10
- 15
- 20
- 25
- 30
- 35
- 40
- 45
- 50
- 55
5. The die-casting machine of claim 2, including an additional piston rod seal (98) engaging said piston rod (21) beyond the first mentioned piston rod seal and additional enclosure means (94) extending from said first mentioned piston rod seal to said additional piston rod seal forming an additional air tight enclosure, and wherein said pressure control means (108) include means (104) generating a vacuum within the first-mentioned enclosure with said piston retracted beyond said inlet opening (60), means (106) introducing an inert gas into said additional enclosure and valve means (103) connecting the additional enclosure with said first-mentioned enclosure to introduce said inert gas into the first-mentioned enclosure with said piston forward of said inlet opening.
  6. The die-casting machine of claim 5, further characterized in that said valve means comprises a valving section (103) of said piston rod (21) having a smaller cross-sectional area than first piston rod seal (98) and located on said piston rod such that said valving section is adjacent to said first piston rod seal to connect the additional enclosure (94) with the first mentioned enclosure with the said piston forward of the inlet opening (60).
  7. A vacuum die-casting machine having a fill chamber (10) with a bore for communicating at a first end with a die (2), a piston (4) extendable in said bore to charge molten metal into the die, a piston rod (21) connected to said piston and extending out of a second end of the fill chamber, and means (90) sealing said second end of said fill chamber characterized by a piston rod seal (98) engaging said piston rod, and enclosure means (94) extending from said fill chamber (10) to said piston rod seal (98) and forming with said piston rod seal an air-tight enclosure at the second end of said fill chamber, said enclosure means (94) being at least laterally flexible to accommodate lateral movement of said piston rod (21) and piston rod seal (98) relative to said fill chamber (10).
  8. A method of operating a die casting machine in which a piston (4) which charges molten metal into a die (2,3) is retracted in a bore in a fill chamber (10) beyond an inlet opening (60) and a vacuum is applied to the fill chamber bore in front of the retracted piston to draw molten metal into the bore in front of the retracted piston to draw molten metal into the bore of the fill chamber through the inlet opening, said method characterized by applying a vacuum behind said piston during application of vacuum in front of the piston.
  9. The method of claim 10, further characterized by introducing an inert gas at about ambient pressure behind the piston (4) in place of said vacuum as said piston is advanced to charge the molten metal in the fill chamber bore into said die and before said piston clears said inlet opening (60).
  10. A method of vacuum die casting an aluminum alloy containing iron in a die containing iron, said method comprising: applying to at least one of the die (2,3) and a fill chamber (10) of the die-casting machine, a lubricant comprising a lubricating species which produces a gas when exposed to molten alloy, applying a vacuum to the fill chamber and die to evacuate air and draw molten alloy into the fill chamber, and charging the molten alloy in the fill chamber into the die to form in the die a cast product, said method characterized by said aluminum alloy comprising less than about 0.5% iron, said lubricant being a water-based lubricating fluid comprising water, said lubricating species at a concentration no more than that which results in a gas content of less than about 10 ml/100 g of alloy in said cast product, and a halogenated salt at a concentration sufficient to substantially inhibit soldering of said alloy to said die or fill chamber, and including evaporating the water from the applied lubricating fluid, and tightly sealing said fill chamber to prevent sucking air into said fill chamber when applying said vacuum to the fill chamber and die, and wherein said molten metal is charged from the fill chamber into the die at gate velocities of at least 15 meters per second.
  11. The method of claim 10, further characterized by applying lubricating fluid comprising 0.5 to 3% by weight of said halogenated salt to said die, and applying lubricating fluid comprising 2 to 7% by weight of said halogenated salt to the fill chamber of said die casting machine.
  12. The method of claim 10, wherein said fill chamber has a bore and a piston slidable in said bore and further characterized in that said water based lubricant is applied to the bore of said fill chamber but not to said piston.
  13. The method of any of the claims 10 through 12, further characterized in that said halogenated salt is potassium iodide.
  14. A vacuum die-casting machine comprising a fill chamber (10) having a bore into which molten metal is drawn by a vacuum, and a piston (4) slidable in said bore of the fill chamber to charge said molten metal into a die on a forward stroke of the piston, and characterized by a thin flexible elongated generally cylindrical skirt seal (140) between said

piston and the bore of said fill chamber and having a forward edge secured to said piston and a floating rearward edge, said thin flexible elongated cylindrical skirt seal having a diameter which provides sealing engagement with the bore of the fill chamber.

- 5 15. The vacuum die-casting machine of claim 14, further characterized by a rigid annular hem ring (142) secured to said rearward edge of said thin flexible elongated cylindrical skirt seal (140) and having a peripheral rearwardly facing cutting edge which strips flash and debris from the bore of said fill chamber on a rearward stroke of said piston.
- 10 16. The vacuum die-casting machine of claim 15, further characterized in that said piston (4') has a generally rearwardly facing annular shoulder (144) with a preset outer diameter and said annular hem ring (142) has an inner diameter less than said preset outer diameter of said shoulder, said hem ring (142) axially engaging said shoulder to transfer to the piston (4') rather than the thin flexible elongated cylindrical skirt seal (140) loading generated by resistance to rearward movement of the hem ring (142) with the rearward stroke of the piston.
- 15 17. The vacuum die-casting machine of claim 15, further characterized in that said piston (4'') has a rearwardly facing socket (160) and including a piston rod (285) having on one end a ball (160) which seats in said socket to effect an articulated connection between said piston and said piston rod, said piston rod having a rearwardly facing shoulder (274) having an outward diameter greater than an inner diameter of said hem ring, said hem ring axially engaging said shoulder on said piston rod to transfer to the piston rod rather than the thin flexible elongated cylindrical skirt seal (282) loading generated by resistance to rearward movement of the hem ring with the rearward stroke of the piston.
- 20 18. The vacuum die-casting machine of either of claim 16 or claim 17, further characterized in that said shoulder and hem ring have conical engagement surfaces extending radially outward and forward.
- 25 19. A vacuum die-casting process characterized by controlling of piston (4) to fill chamber (10) clearance for the metal feed stroke of the piston.
- 30
- 35
- 40
- 45
- 50
- 55

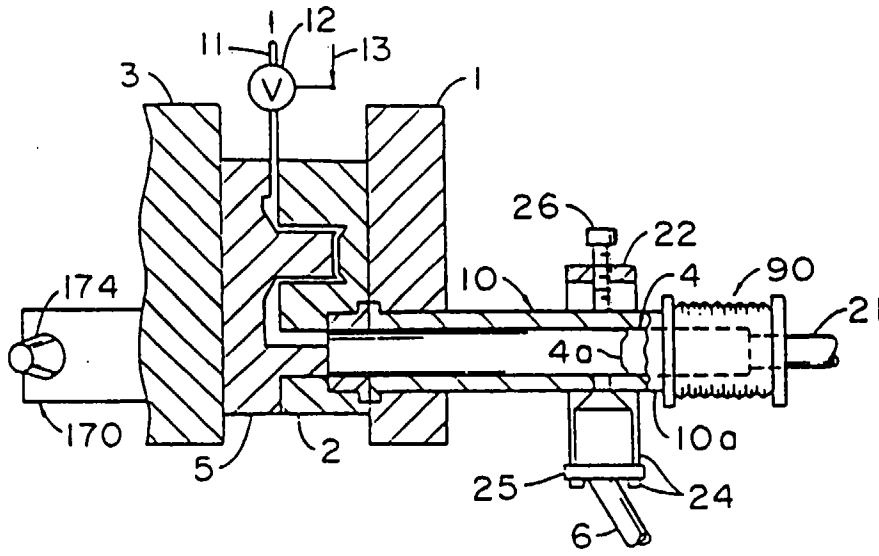

FIG. 1

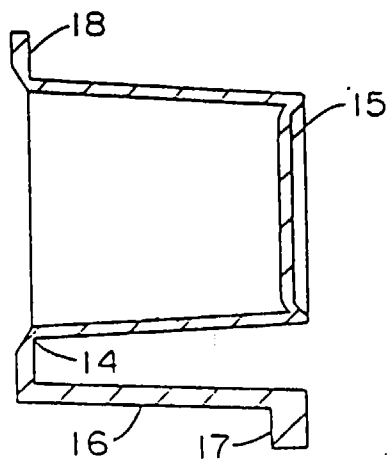
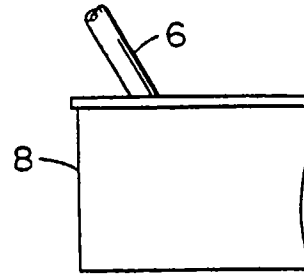

FIG. 2

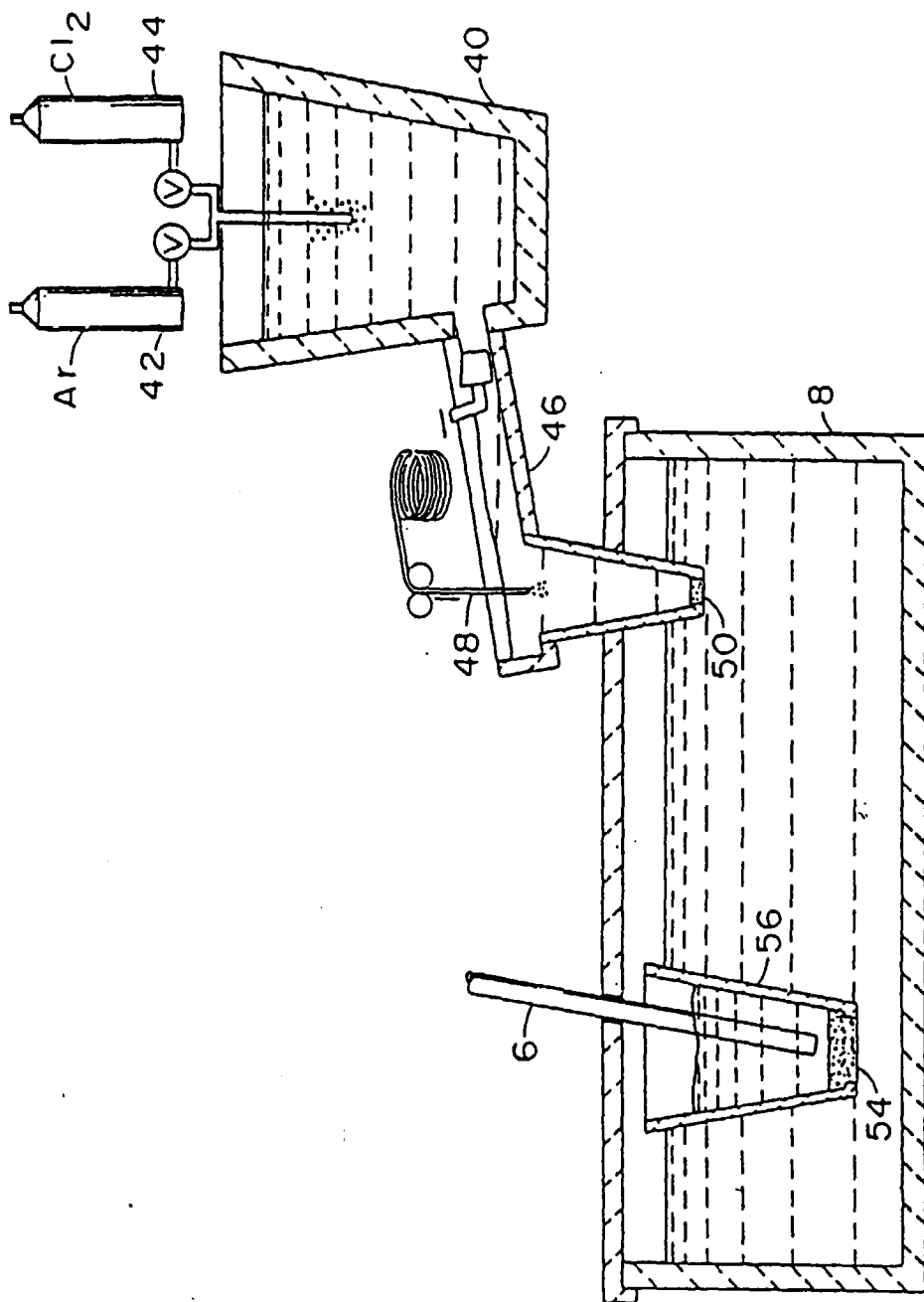
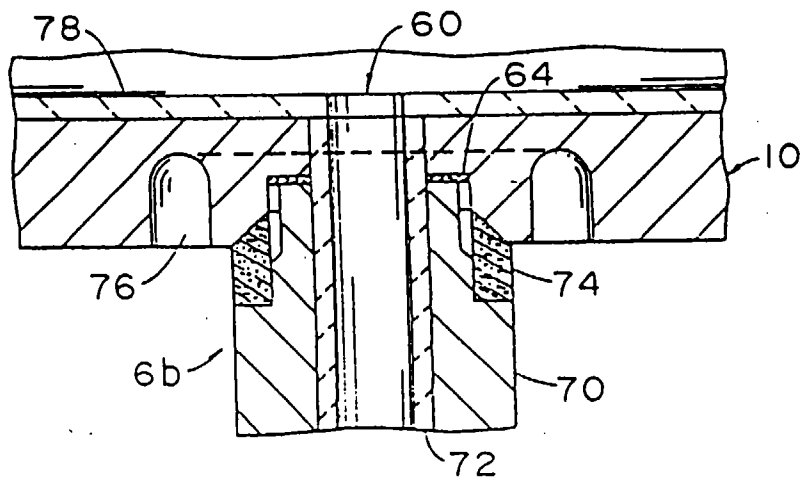
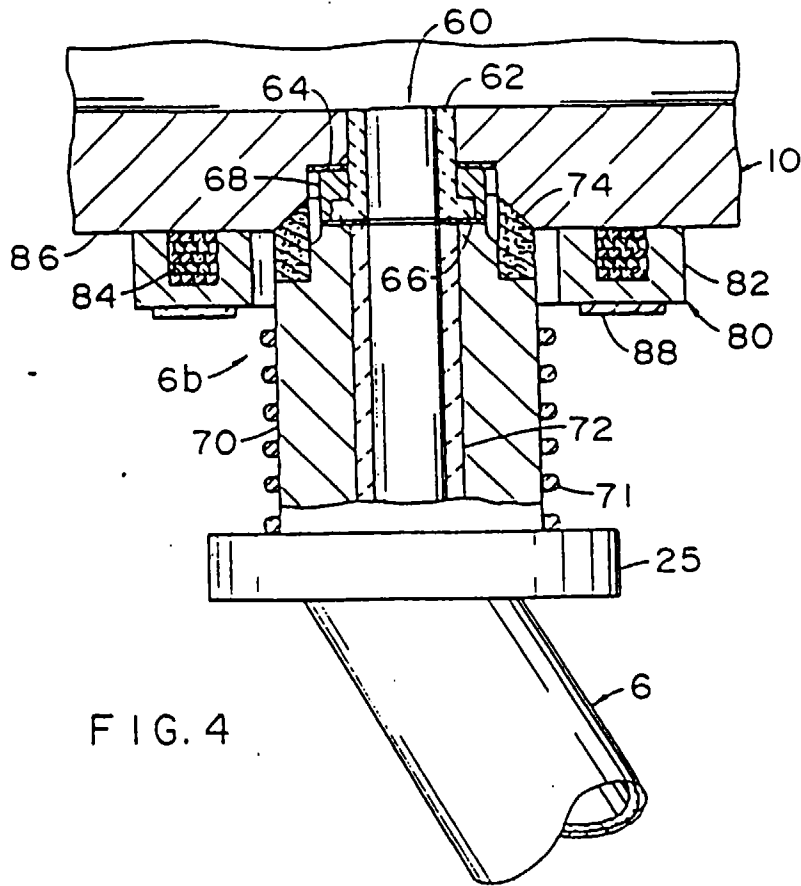

FIG. 3



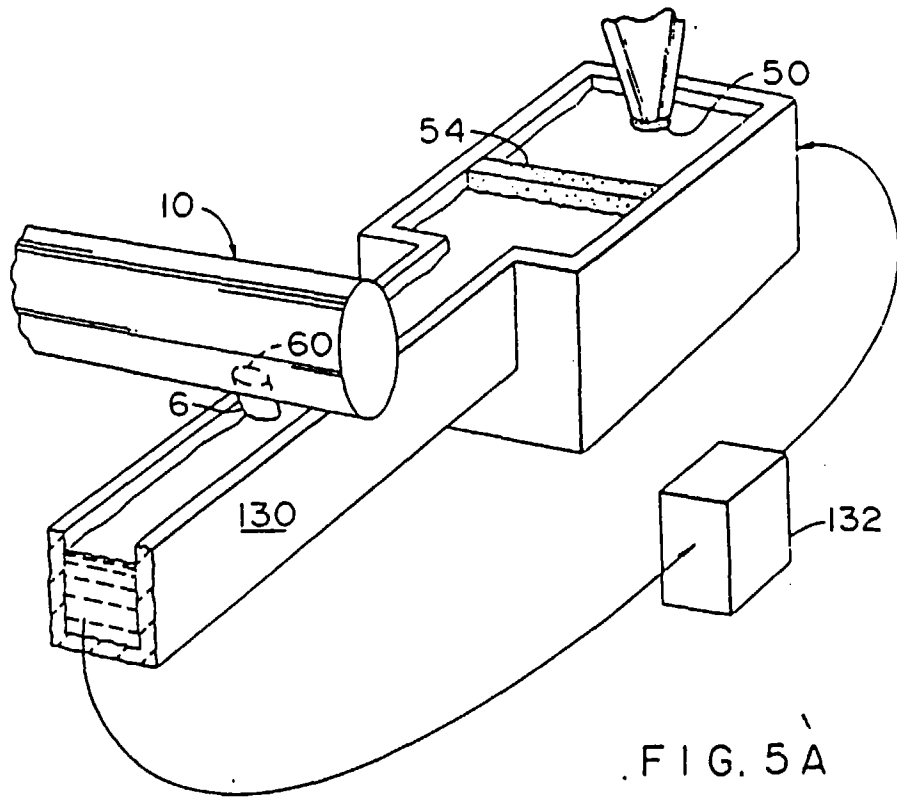

FIG. 5A

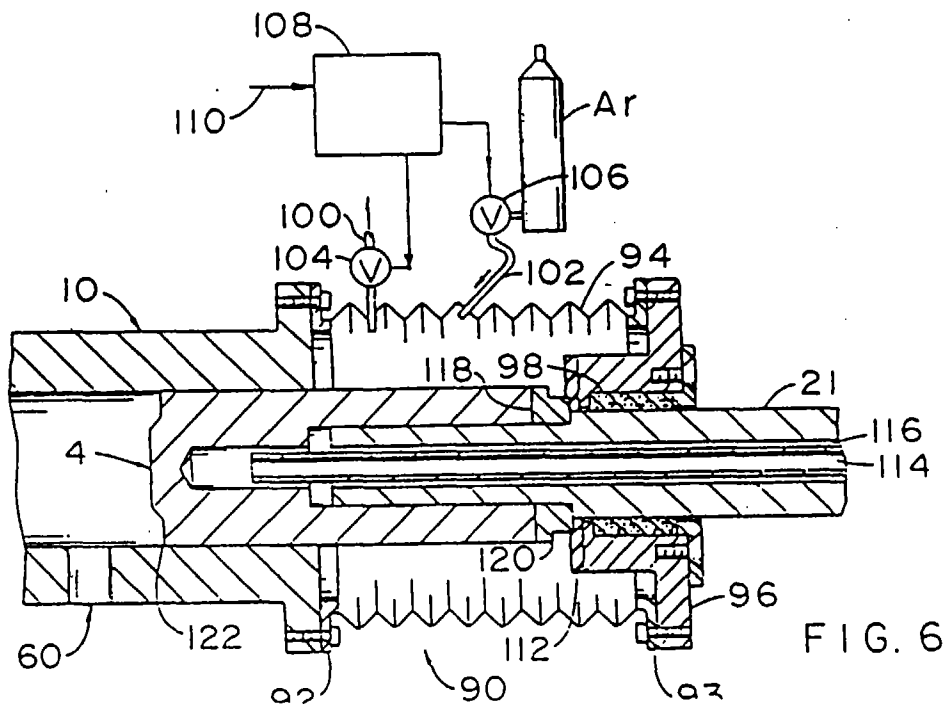

FIG. 6

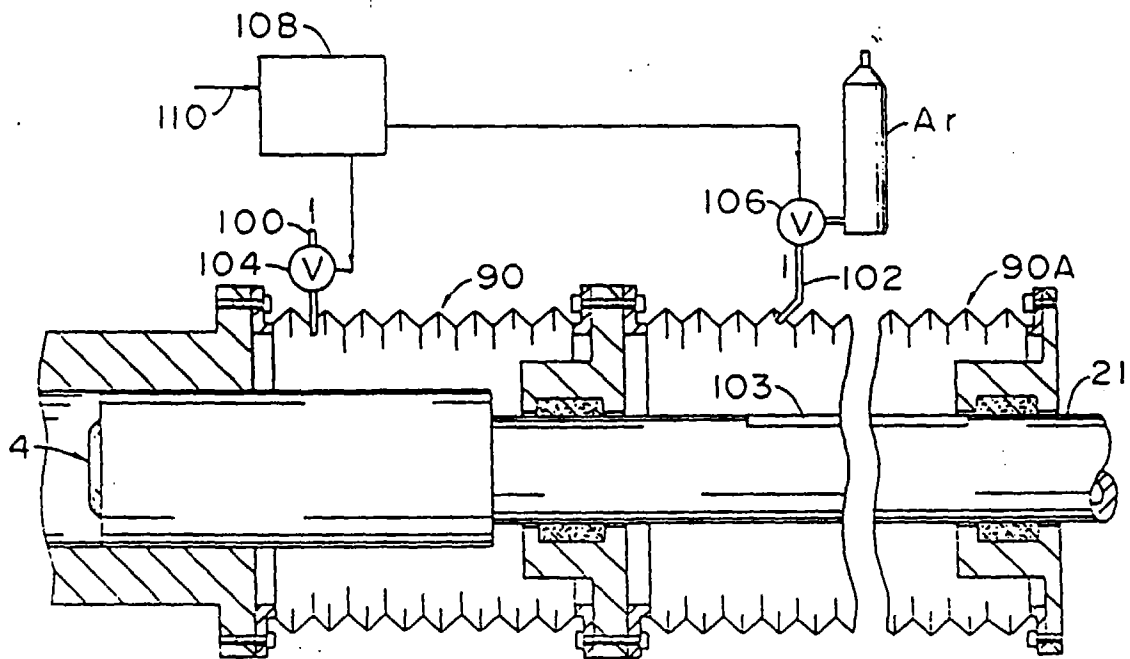
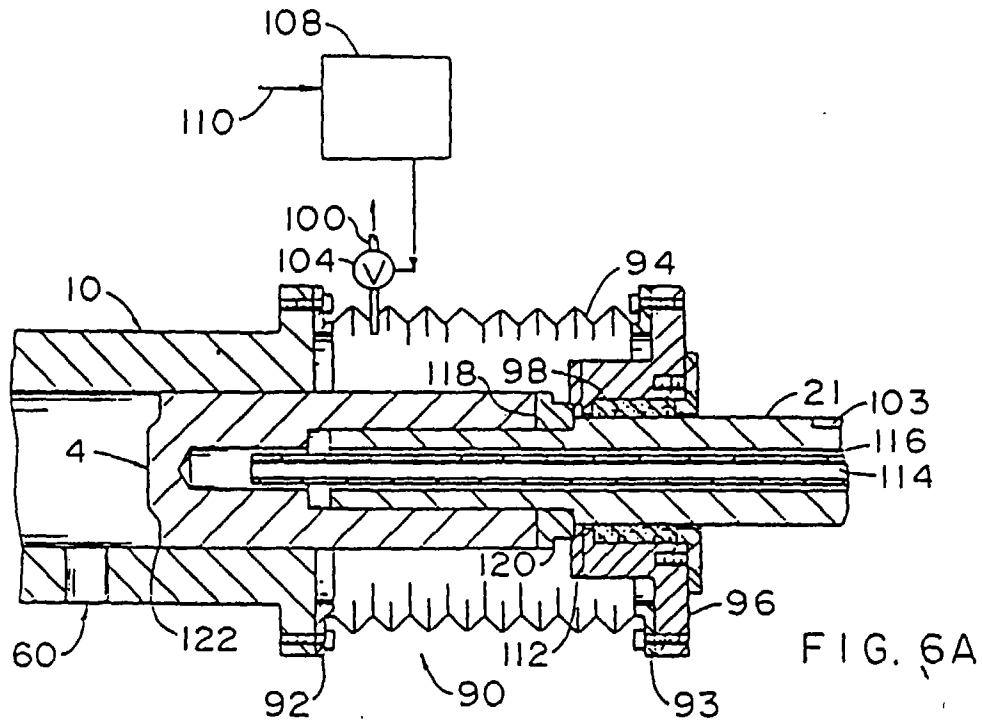

FIG. 6B

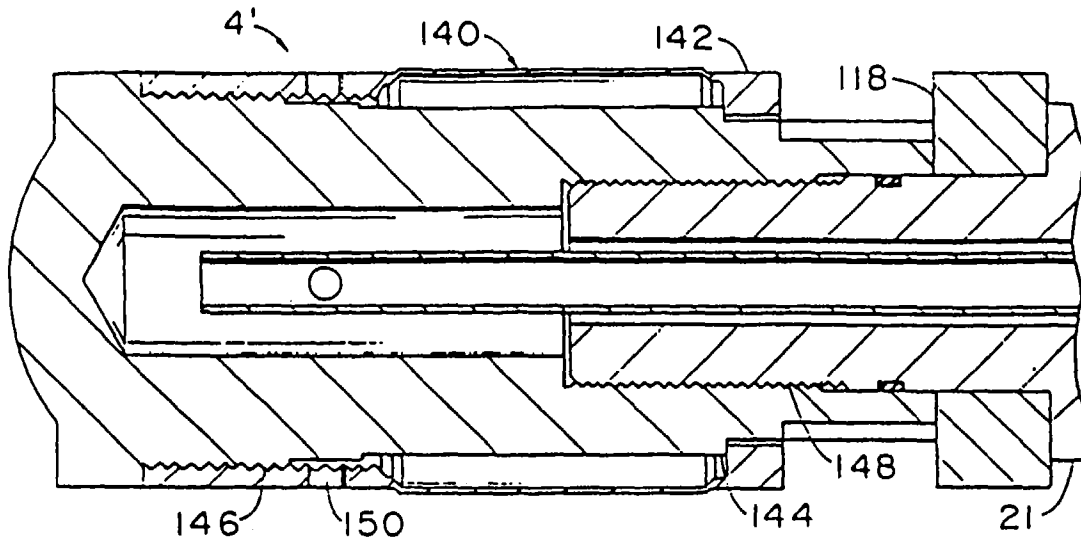

FIG. 7

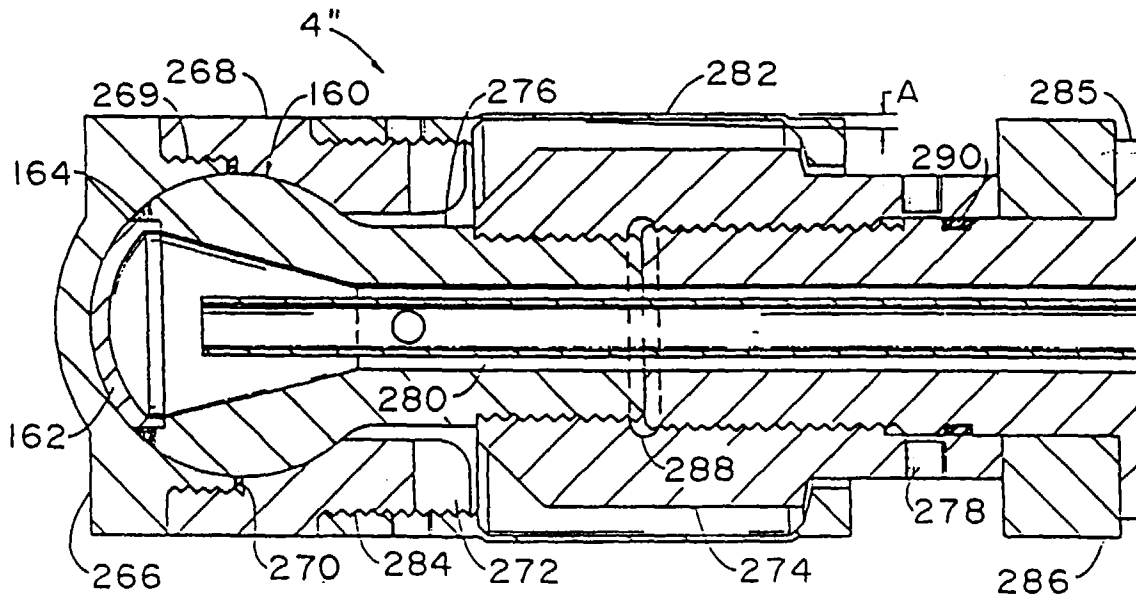
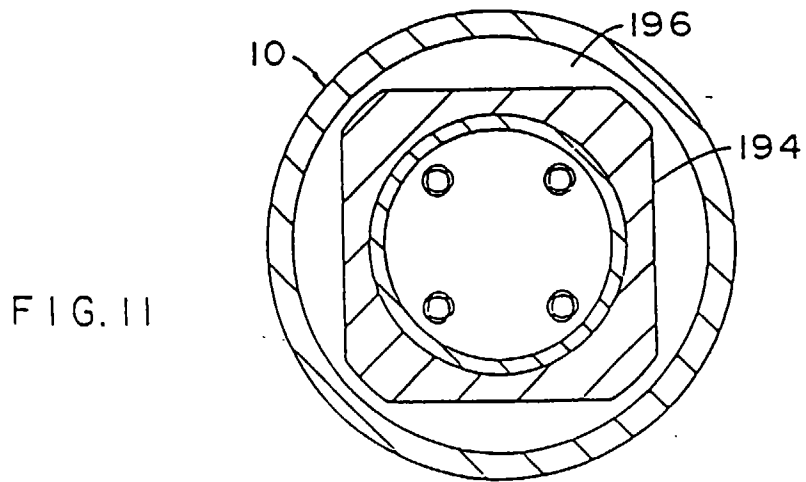
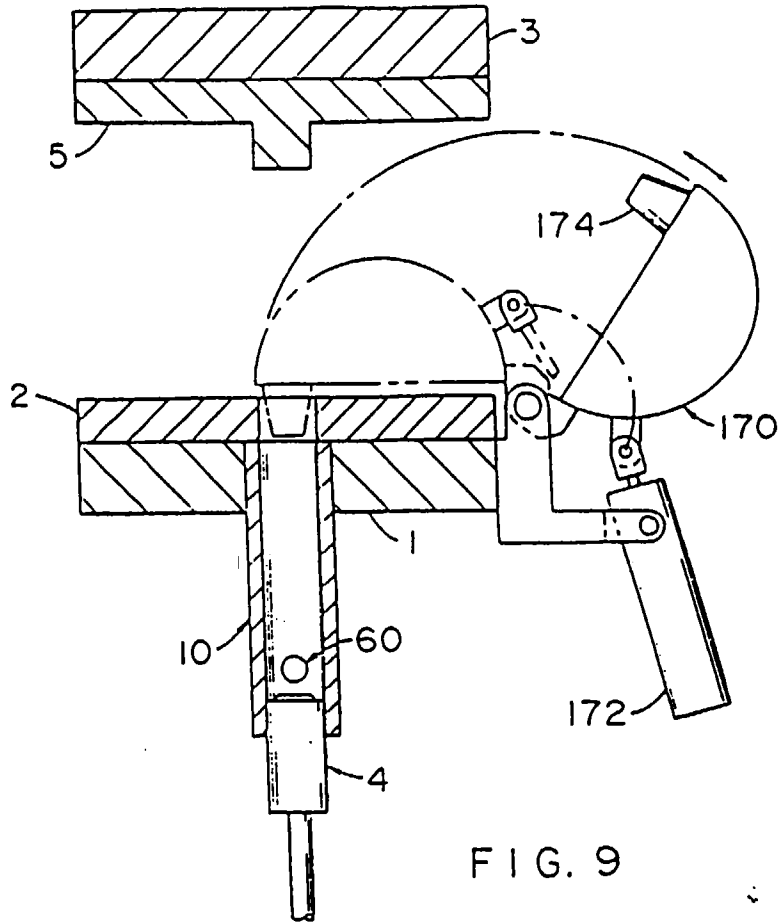
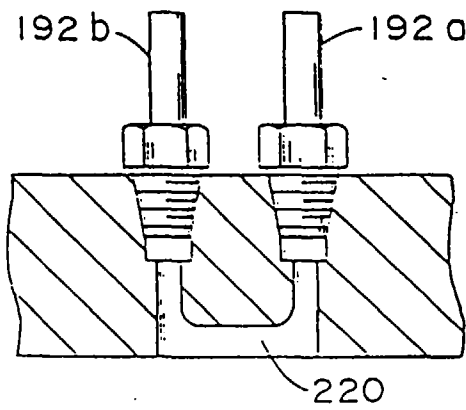
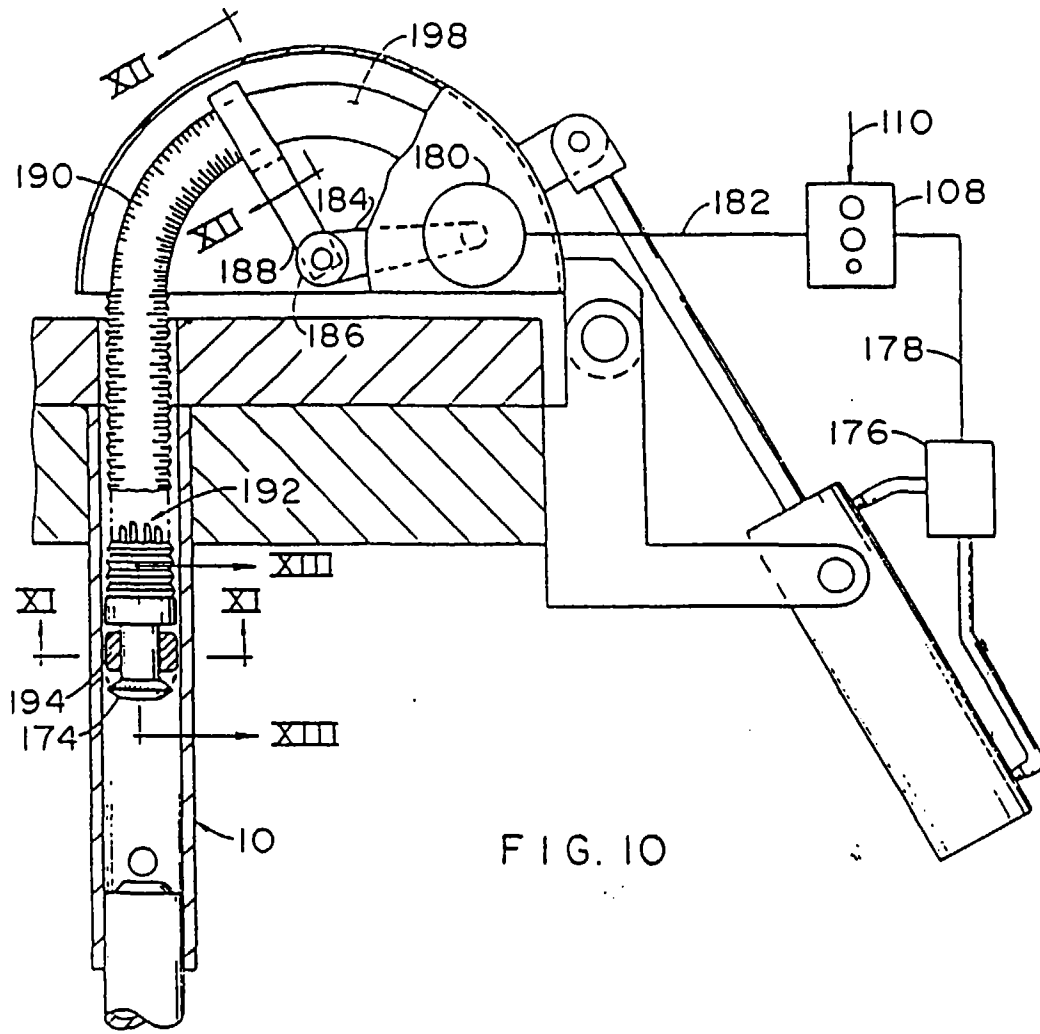

FIG. 8





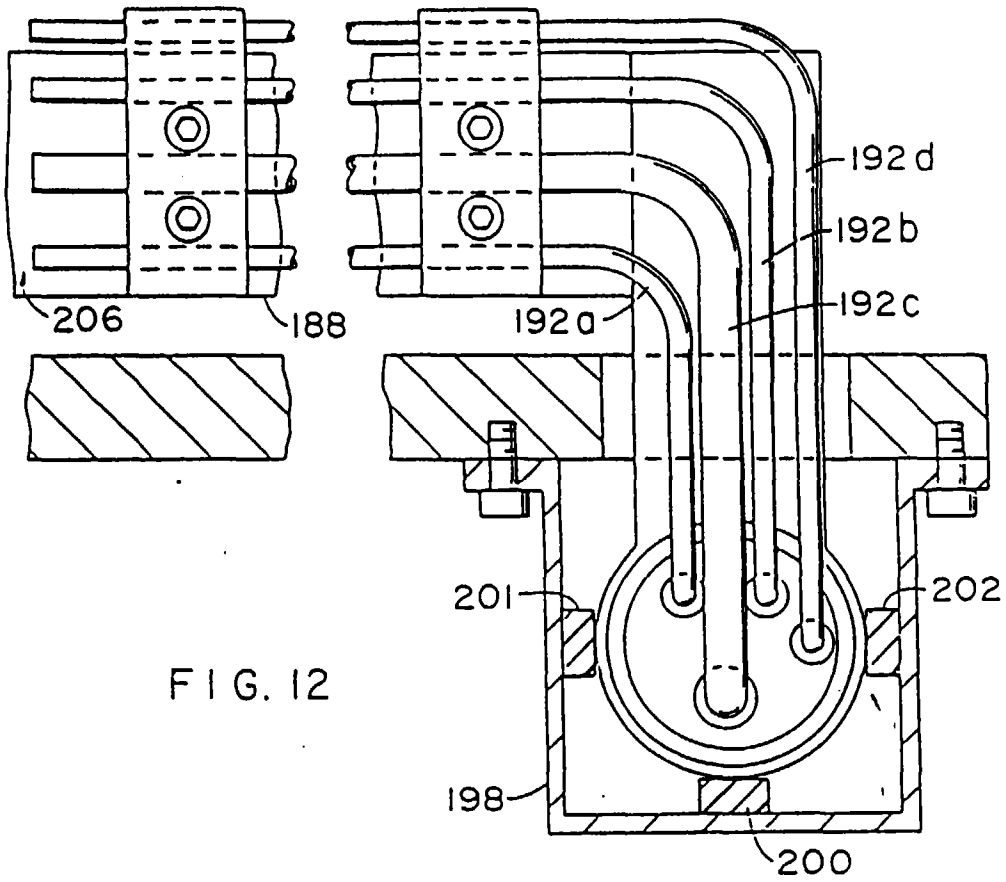

FIG. 12

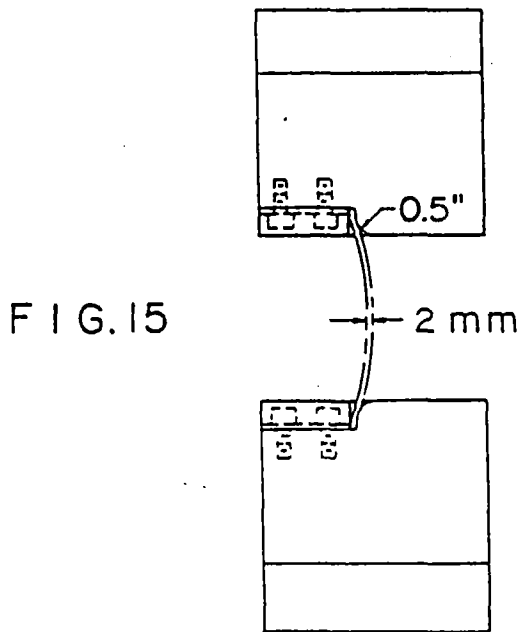
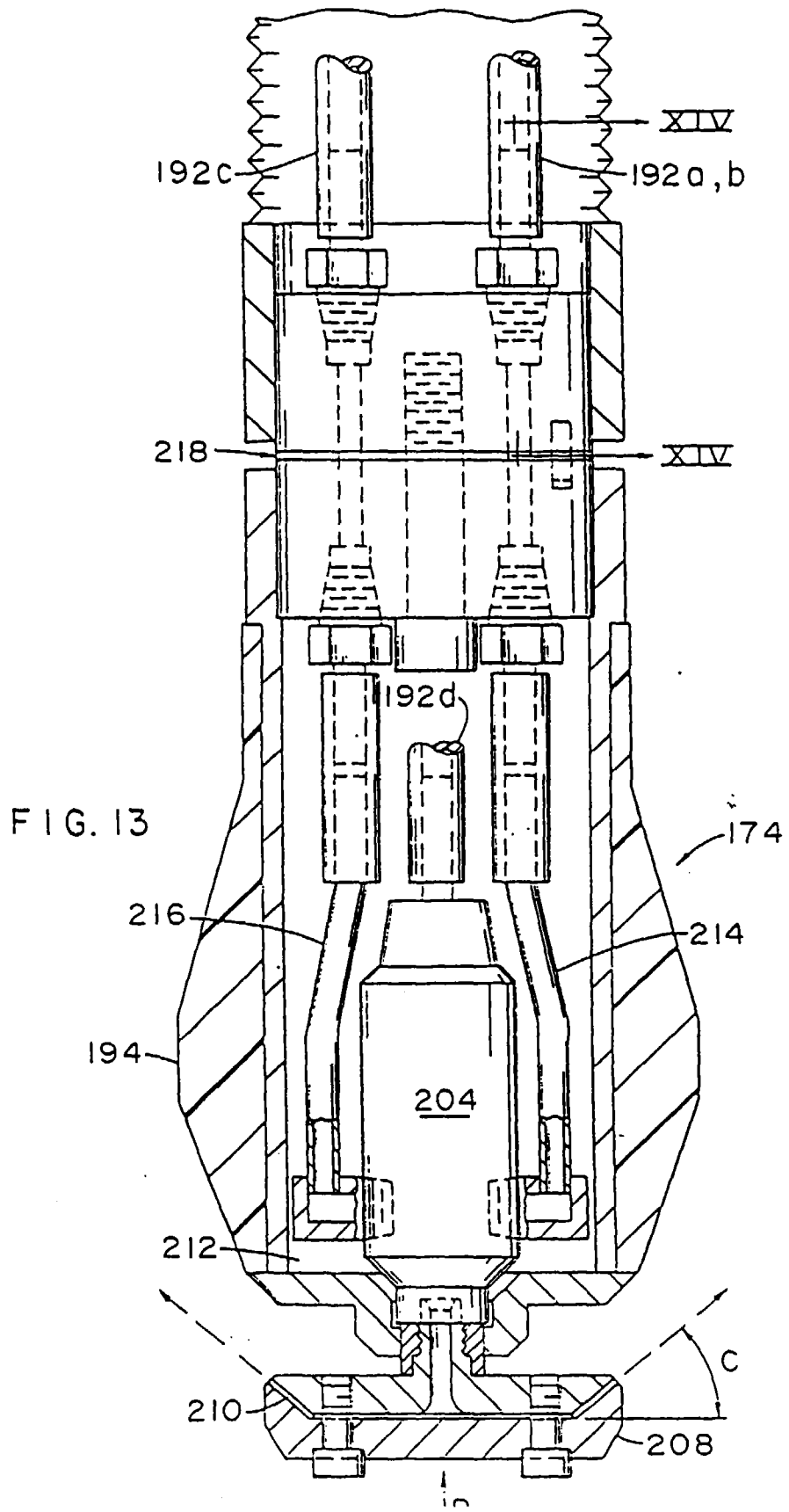
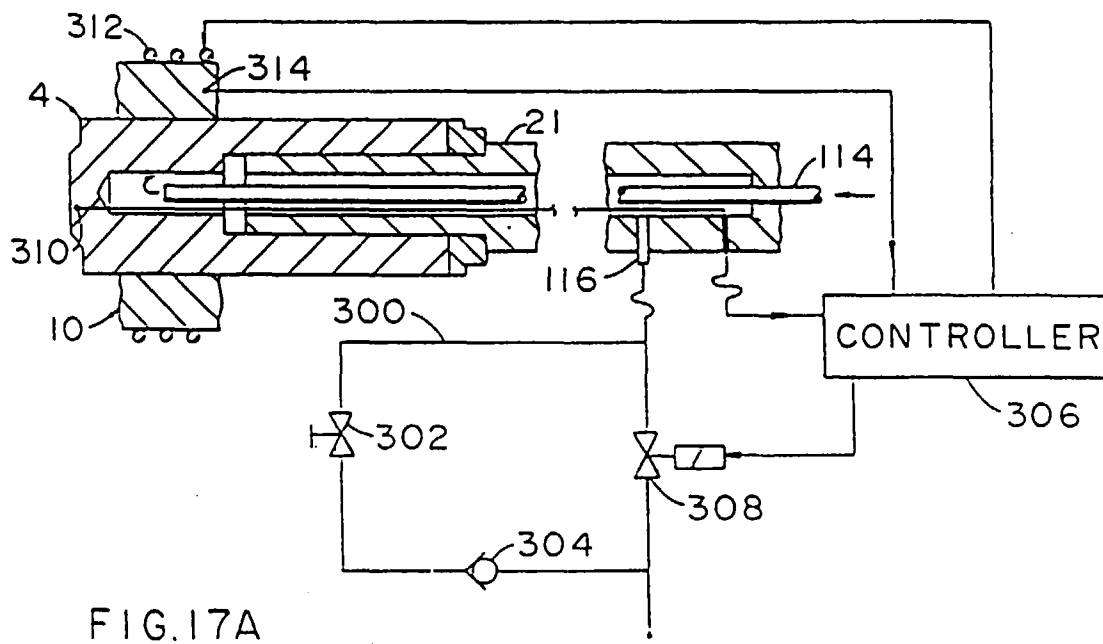
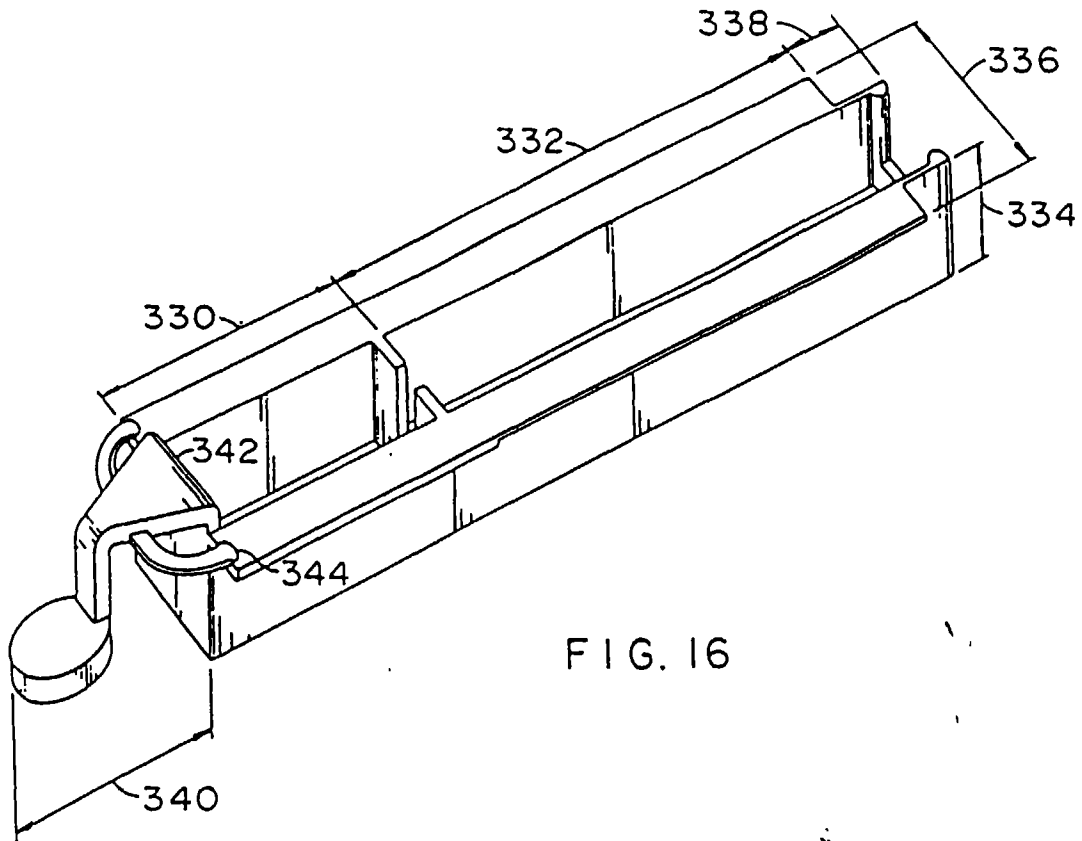

FIG. 15





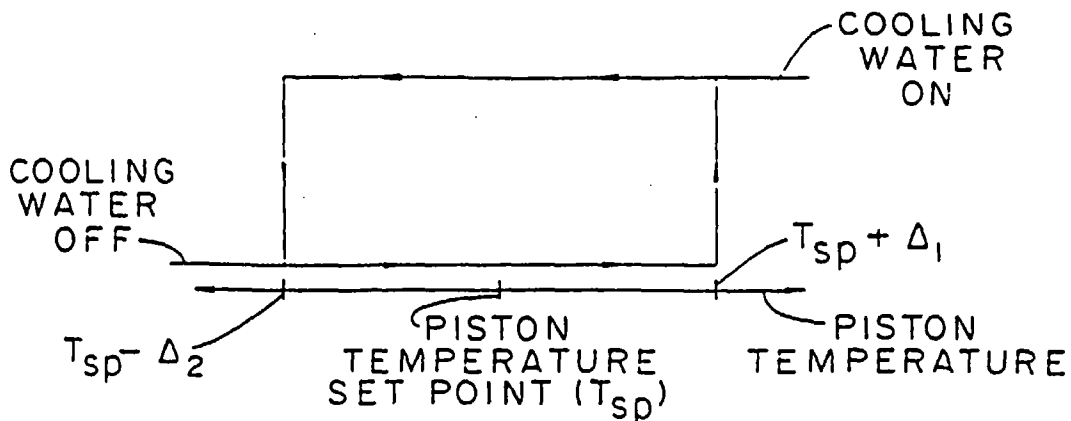

FIG. 17B

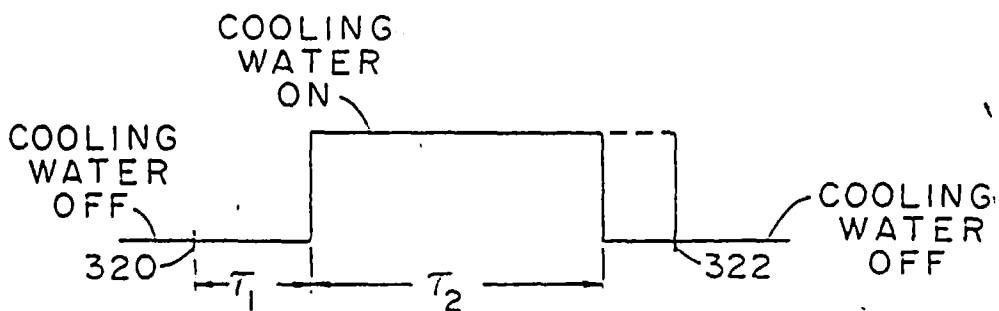

FIG. 17C

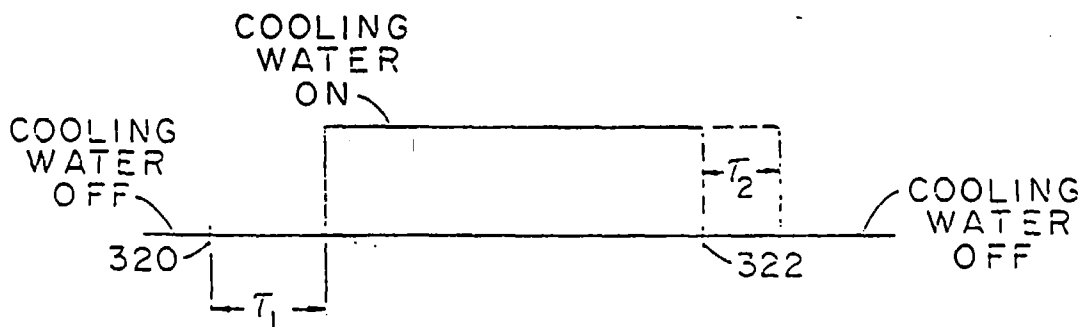

FIG. 17D



European Patent  
Office

EUROPEAN SEARCH REPORT

Application Number  
EP 97 10 9129

DOCUMENTS CONSIDERED TO BE RELEVANT			
Category	Citation of document with indication, where appropriate, of relevant passages	Relevant to claim	CLASSIFICATION OF THE APPLICATION (Int.Cl.6)
D,A	US 4 476 911 A (LOSSACK EDGAR ET AL) 16 October 1984 * claims *	1,7,8, 10,14,19	B22D17/14 B22D17/20 B22D41/50 B22D17/30
D,A	--- US 2 864 140 A (D.M. MORGENSTERN) * abstract; claims; figure 1 *	1,7,8, 10,14,19	B22D17/32
A	--- DE 26 41 116 A (REIS WALTER) 30 March 1978 * claim 2 *	1,7,8, 10,14,19	
A	--- US 4 534 403 A (HARVILL JOHN I) 13 August 1985 * abstract; figure 1 *		
			TECHNICAL FIELDS SEARCHED (Int.Cl.6)
			B22D
The present search report has been drawn up for all claims			
Place of search		Date of completion of the search	Examiner
THE HAGUE		13 October 1997	WOUDENBERG, S
CATEGORY OF CITED DOCUMENTS			
X : particularly relevant if taken alone Y : particularly relevant if combined with another document of the same category A : technological background O : non-written disclosure P : intermediate document		T : theory or principle underlying the invention E : earlier patent document, but published on, or after the filing date D : document cited in the application L : document cited for other reasons & : member of the same patent family, corresponding document	

EPO FORM 1503 03.82 (P04C01)