



Europäisches Patentamt
European Patent Office
Office européen des brevets



(11) **EP 0 817 341 A1**

(12) **EUROPEAN PATENT APPLICATION**

(43) Date of publication:
07.01.1998 Bulletin 1998/02

(51) Int. Cl.⁶: **H01T 13/39**

(21) Application number: 97110583.8

(22) Date of filing: 27.06.1997

(84) Designated Contracting States:
**AT BE CH DE DK ES FI FR GB GR IE IT LI LU MC
NL PT SE**

(72) Inventors:
• **Matsutani, Wataru**
Mizuho-ku, Nagoya-shi, Aichi (JP)
• **Kagawa, Junichi**
Mizuho-ku, Nagoya-shi, Aichi (JP)

(30) Priority: 28.06.1996 JP 188347/96
28.11.1996 JP 335119/96

(74) Representative:
Grünecker, Kinkeldey,
Stockmair & Schwanhäusser
Anwaltssozietät
Maximilianstrasse 58
80538 München (DE)

(71) Applicant:
NGK SPARK PLUG CO., LTD
Mizuho-ku Nagoya-shi Aichi (JP)

(54) **Spark plug**

(57) Spark plug has a central electrode, an insulator provided exterior to the central electrode, main metallic shell provided exterior to the insulator in such a way that the central electrode protrudes from one end, and a ground electrode coupled at one end to the main metallic shell and which has the other end disposed to face

the central electrode 3, with a chip being secured to either the central electrode or the ground electrode or both to form spark discharge gap g. The chip is made of a metal based on Ir which contains Rh in an amount ranging from 3 to 50 wt% (50 wt% being not inclusive).

FIG.1

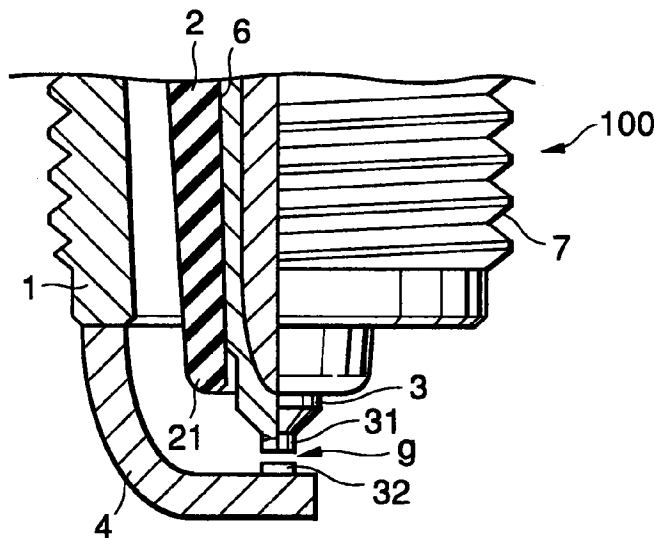

EP 0 817 341 A1

DescriptionBACKGROUND OF THE INVENTION1. Field of the Invention

The present invention relates to a spark plug for use in internal combustion engines.

2. Description of the Related Art

Conventional spark plugs for use in internal combustion engines such as automotive engines have the igniting portion formed of a platinum (Pt) alloy chip welded to the tip end of an electrode in order to improve its resistance to spark consumption. However, in view of the high cost of platinum, it has been proposed to use less expensive iridium (Ir) as a chip material.

A problem with the use of Ir as a material to constitute the igniting portion of the spark plug is that Ir is easy to oxidize and evaporate in a high temperature range of 900 to 1,000°C. Therefore, if it is directly used in the igniting portion of the electrode, it is more consumed by oxidation and evaporation than by spark. Therefore, the spark plug using Ir in the igniting portion of an electrode is highly durable under low-temperature conditions as in driving on city roads but their endurance drops considerably during continuous running at high speed.

SUMMARY OF THE INVENTION

It is an object of the present invention to provide a spark plug having an igniting portion chiefly made of Ir and which yet is sufficiently resistant to consumption by oxidation and evaporation of the Ir component at elevated temperatures to assure high endurance not only during driving on city roads but also during continuous running at high speed.

A spark plug according to the present invention is comprised of: a central electrode; an insulator provided exterior to the central electrode; a main metallic shell provided exterior to the insulator; a ground electrode coupled at one end to the main metallic shell and which has the other end disposed to face the central electrode; and an igniting portion that is secured to at least one of the central electrode and the ground electrode for forming a spark discharge gap; wherein the igniting portion is made of an alloy based on Ir which contains Rh in an amount ranging from 3 to 50 wt% (50 wt% being not inclusive).

According to the present invention, the igniting portion of an electrode which forms a spark discharge gap is made of an alloy that is mainly made of Ir and which contains an amount of Rh in the stated range. Therefore, the consumption due to oxidation and evaporation of the Ir component at high temperatures is effectively retarded to thereby realize a highly durable spark plug.

BRIEF DESCRIPTION OF THE DRAWINGS

In the accompanying drawings:

Fig. 1 is a partial front sectional view of the spark plug of the invention;

Fig. 2 is a sectional view showing enlarged the essential part of the same spark plug;

Fig. 3 is a graph showing the relationship between the Rh content of the alloy forming the igniting portions of the spark plug and the increase in the spark discharge gap (in Example 1 under condition A);

Fig. 4 is a graph showing the relationship between the Rh content of the alloy forming the igniting portions of the spark plug and the increase in the spark discharge gap (in Example 1 under condition B); and

Fig. 5 is a graph showing the relationship between the Rh content of the alloy forming the igniting portions of the spark plug and the increase in the spark discharge gap (in Example 1 under condition C).

DETAILED DESCRIPTION OF THE INVENTION

Detailed description of the present invention will be described as follows.

The spark plug according to the present invention has a central electrode, an insulator provided exterior to the central electrode, a main metallic shell provided exterior to the insulator, a ground electrode coupled at one end to the main metallic shell and which has the other end disposed to face the central electrode, and an igniting portion that is secured to either the central electrode or the ground electrode or both for forming a spark discharge gap, wherein the igniting portion is made of an alloy based on Ir which contains Rh in an amount ranging from 3 to 50 wt% (50 wt% being not inclusive).

The present inventors have found that if the igniting portion of an electrode which forms a spark discharge gap is made of an alloy that is mainly made of Ir and which contains an amount of Rh in the stated range, the consumption due to oxidation and evaporation of the Ir component at high temperatures is effectively retarded to thereby realize a highly durable spark plug.

In order to form the igniting portion, a chip made of a metal having the stated composition may be joined by welding to the ground electrode and/or the central electrode. The term "igniting portion" as used herein shall refer to that part of the joined chip which has not been subject to the effect of the compositional change due to welding (e.g., the portion other than that which has been alloyed with the constituent material of the ground or central electrode upon welding).

If the Rh content of the alloy is less than 3%, the effectiveness of Rh in retarding the oxidation and evaporation of Ir is insufficient to prevent premature consumption of the igniting portion. Hence, the endurance of the spark plug is reduced. In this case, the igniting

portion is consumed primarily in the tip end face of the chip welded to the central electrode and/or the ground electrode. However, the lateral sides of the chip may also be consumed if the Rh content is reduced. In such an extreme situation, the cross-sectional area of the chip through which a current is applied to cause spark discharge will decrease and the applied electric field tends to concentrate on the tip end face of the chip, whereby the consumption of the igniting portion will proceed at an accelerated rate and the life of the spark plug comes to an end prematurely. Therefore, the Rh content of the alloy is desirably adjusted to lie within such a range that the consumption of the igniting portion is unlikely to occur not only in the tip end face of the chip but also on its lateral sides. On the other hand, if the Rh content of the alloy is 50 wt% or more, the melting point of the alloy will drop and the endurance of the spark plug will deteriorate accordingly. Therefore, the Rh content of the alloy is preferably adjusted to lie within the range of 3 to 50 wt% (50 wt% being not inclusive), desirably 7 to 30 wt%, more desirably 15 to 25 wt%, most desirably 18 to 22 wt%.

Embodiments of the invention will now be described with reference to the accompanying drawings as follows.

Fig. 1 shows an embodiment of the present invention. In the drawing, a spark plug 100 has a tubular main metallic shell 1, an insulator 2 fitted into the metallic shell 1 in such a way that the tip end 21 protrudes from the metallic shell 1, a central electrode 3 provided within the insulator 2 in such a way that the igniting portion 31 formed at the tip end protrudes from the insulator 2, and a ground electrode 4 coupled at one end to the main metallic shell 1 as by welding and which has the other end bent laterally such that its lateral side faces the tip end of the central electrode 3. The ground electrode 4 has an igniting portion 32 formed in such a way that it faces the igniting portion 31 of the central electrode 3; the clearance between the two igniting portions 31 and 32 forms a spark discharge gap g.

The insulator 2 is a sinter of a ceramic material such as alumina or aluminum nitride as a main constituent, and it has an axial bore 6 through which the central electrode 3 is to be fitted. The main metallic shell 1 is a cylindrical form made of a metal such as a low-carbon steel and which provides a housing for the spark plug 100. The circumference of the metallic shell 1 has a threaded portion 7 formed to assist in the mounting of the spark plug 100 on an engine block (not shown).

The main body 3a of the central electrode 3 and the main body 4a of the ground electrode 4 are both typically made of a Ni alloy. The igniting portion 31 of the central electrode 3 and the opposed firing portion 32 of the ground electrode 4 are both made of an alloy based on Ir and which contains Rh in an amount ranging from 3 to 50 wt% (50 wt% being not inclusive). The Rh content of the alloy is desirably adjusted to lie within a range of 7 to 30 wt%, more desirably 15 to 25 wt%, most desir-

ably 18 to 22 wt%.

As shown in Fig. 2, the main body 3a of the central electrode 3 tapers at the tip end and its tip end face is formed flat. A disk-shaped chip having an alloy formula for the igniting portion 31 is placed on the flat tip end face and laser welding, electron beam welding, resistance welding or other suitable welding technique is applied to the periphery of the joined surfaces to form a weld line W, whereby the chip is securely fixed to the tip end face of the central electrode 3 to form the igniting portion 31. To form the opposed igniting portion 32, a similar chip is placed on the ground electrode 4 in registry with the position of the igniting portion 31 and a weld line W is similarly formed on the periphery of the joined surfaces, whereby the chip is securely fitted to the ground electrode 4 to form the igniting portion 32. The chips may be formed from a molten material obtained by mixing the necessary alloy ingredients to give the stated formula and melting the mixture; alternatively, the chips may be formed from a sinter obtained by shaping into a compact a suitable alloy powder or a mixture of the powders of elemental metal components in specified proportions and sintering the compact.

If the chips are formed of a molten alloy, a raw material made of the molten alloy may be subjected to a working process including at least one of rolling, forging, drawing, cutting, shearing and blanking steps, whereby the chips are produced in a specified shape. Steps such as rolling, forging and cutting may be performed with the alloy being heated to a specified temperature (to effect "hot" or "warm" working). The temperature for these steps which is variable with the alloy composition may typically be at least 700°C.

Stated more specifically, a molten alloy may be hot rolled to a sheet, which is hot blanked to chips of a specified shape; alternatively, the molten alloy may be hot rolled or forged to a wire or rod shape, which is cut to chips of a specified length. The iridium (Ir) which is the chief component of the chips has low ductility or malleability in its elemental form; however, in the presence of added Rh, the workability of the Ir is improved such that the resulting alloy can be rolled or forged into a sheet, a rod or a wire with great ease compared to the case where Rh is not added. Stated specifically, defects such as cracking are less likely to occur in the raw alloy material being in the process of rolling or forging and this in turn contributes to improvements in the efficiency of chip production and the materials yield. It should be noted here that the workability of the raw alloy material will increase with increasing Rh addition.

If desired, either one of the two opposed igniting portions 31 and 32 may be omitted. If this is the case, the spark discharge gap g is formed between the igniting portion 31 (or the opposed igniting portion 32) and the ground electrode 4 (or the central electrode 3).

The spark plug 100 operates according to the following mode of action. The spark 100 is fitted on an engine block by means of the threaded portion 7 and

used as a source to ignite an air-fuel mixture that is supplied into the combustion chamber. The igniting portion 31 and the opposed igniting portion 32 define the spark discharge gap g ; since both igniting portions are made of the aforementioned alloy, their consumption due to the oxidation and evaporation of Ir is sufficiently retarded to ensure that the spark discharge gap g will not increase for a prolonged period, thereby extending the life of the spark plug 100.

EXAMPLES

Example 1

Specified amounts of Ir and Rh were mixed and melted to prepare alloy samples containing various amounts of Rh in the range of 0 to 60 wt%, with the balance being substantially composed of Ir (comparative samples: Rh = 0 and 60 wt%). The samples were hot rolled to sheets, from which disk-shaped chips measuring 0.7 mm in diameter and 0.5 mm in thickness were sliced by electrical discharge machining. A chip prepared from a molten alloy consisting of 13 wt% Ir and the balance Pt was also fabricated as a comparison. The thus fabricated chips were used to form the igniting portion 31 of the spark plug 100 and the opposed igniting portion 32 (to provide a spark discharge gap g of 1.1 mm). The individual plugs were subjected to performance tests under the following conditions.

Condition A (simulating continuous running at high speed):

A six-cylinder gasoline engine (piston displacement = 3,000 cc) was fitted with the plug under test and operated continuously at full throttle for 300 hours at a rotational speed of 6,000 rpm (with the temperature of the central electrode rising to about 900°C); after the engine operation, the increase in the spark discharge gap g on the plug was measured. The result is shown in Fig. 3 in terms of the relationship between the Rh content of the alloy and the increase in the spark discharge gap.

Condition B (simulating cruising on city roads):

A four-cylinder gasoline engine (piston displacement = 2,000 cc) was fitted with the plug under test and operated for 1,000 hours through cycles, each consisting of 1-min idling, 30-min running at full throttle and a rotational speed of 3,500 rpm and 20-min running at half throttle and a rotational speed of 2,000 rpm, with the temperature of the central electrode rising to about 780°C; after the engine operation, the increase in the spark discharge gap g on the plug was measured. The result is shown in Fig. 4 in terms of the relationship between the Rh content of the alloy and the increase in the spark discharge gap.

The result of the test under condition B indicates that the plugs using chips made of alloy formulae within the range of the invention experienced only small increases in the spark discharge gap g whereas the comparative plugs (Rh = 60 wt%, and Pt-Ir alloy) had the spark discharge gap increased markedly. The difference of the invention samples with respect to the comparisons was more pronounced under condition A of a higher load than condition B. It is also clear from Fig. 3 that the increase in the spark discharge gap decreased stepwise as the range of the Rh content varied from that of 3 to 50 wt% to 7 to 30 wt% and then to 15 to 25 wt%; in particular, the plugs using chips containing 15 to 25 wt% of Rh exhibited a very high level of endurance in spite of the hostile operating condition.

It should also be noted that compared to a raw material that was solely composed of elemental Ir in the absence of Rh, the raw alloy materials containing 15 to 25 wt% of Rh tended to develop less cracking when they were hot rolled to sheets.

Examples 2

Specified amounts of Ir and Rh were mixed and melted to prepare alloy samples containing Rh in 15, 18, 20, 22 and 25 wt%, with the balance being substantially composed of Ir. Chips were fabricated from these alloy samples and used to produce spark plugs as in Example 1. The plugs were subjected to a performance test under the following condition C which was more hostile than condition A employed in Example 1.

Condition C:

A four-cylinder gasoline engine (piston displacement = 1,600 cc) was fitted with the plug under test and operated continuously at full throttle for 300 hours at a rotational speed of 6,250 rpm (with the temperature of the central electrode rising to about 950°C); after the engine operation, the increase in the spark discharge gap g on the plug was measured. The result is shown in Fig. 5 in terms of the relationship between the Rh content of the alloy and the increase in the spark discharge gap.

It is clear from Fig. 5 that even under condition C which was more hostile than condition B, the plugs using the chips containing 18 to 22 wt% of Rh experienced smaller increases in the gap and proved to be more durable than the plugs using the chips containing Rh in amounts outside the stated range.

Claims

1. A spark plug comprising:

- a central electrode;
- an insulator provided exterior to said central electrode;

a main metallic shell provided exterior to said insulator;

a ground electrode coupled at one end to said main metallic shell and which has the other end disposed to face said central electrode; and
an igniting portion that is secured to at least one of said central electrode and said ground electrode for forming a spark discharge gap;

wherein said igniting portion is made of an alloy based on Ir which contains Rh in an amount ranging from 3 to 50 wt% (50 wt% being not inclusive).

2. A spark plug according to claim 1, wherein the alloy of which said igniting portion is made contains Rh in an amount ranging from 7 to 30 wt%.

3. A spark plug according to claim 1, wherein the alloy of which said igniting portion is made contains Rh in an amount ranging from 15 to 25 wt%.

4. A spark plug according to claim 1, wherein the alloy of which said igniting portion is made contains Rh in an amount ranging from 18 to 22 wt%.

5

10

15

20

25

30

35

40

45

50

55

FIG.1

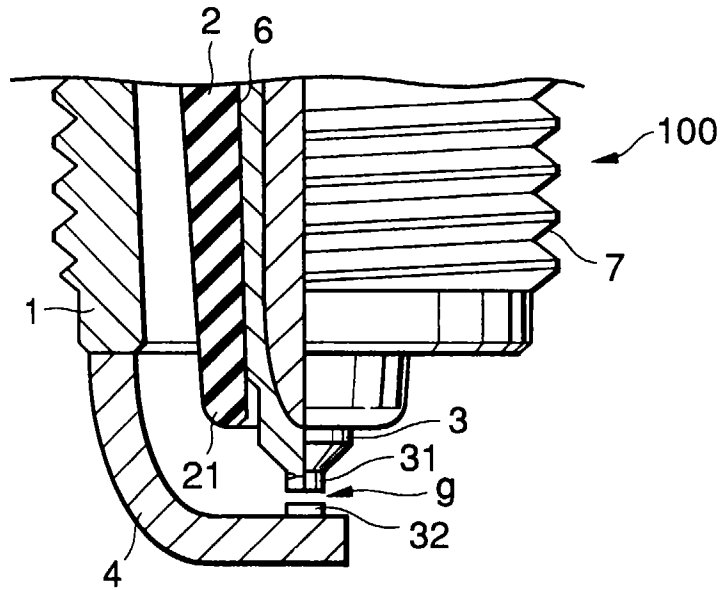

FIG.2

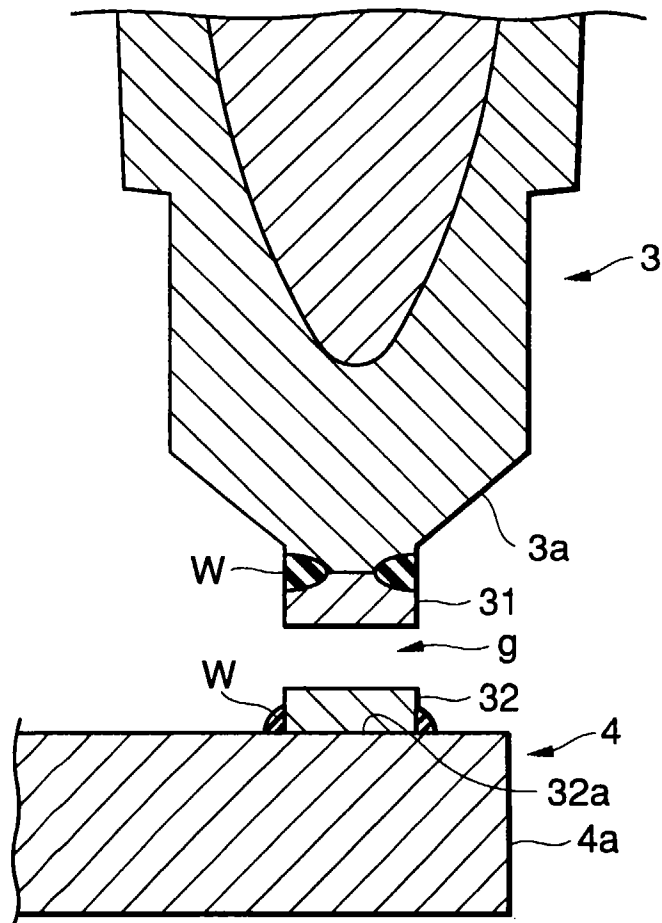

FIG.3

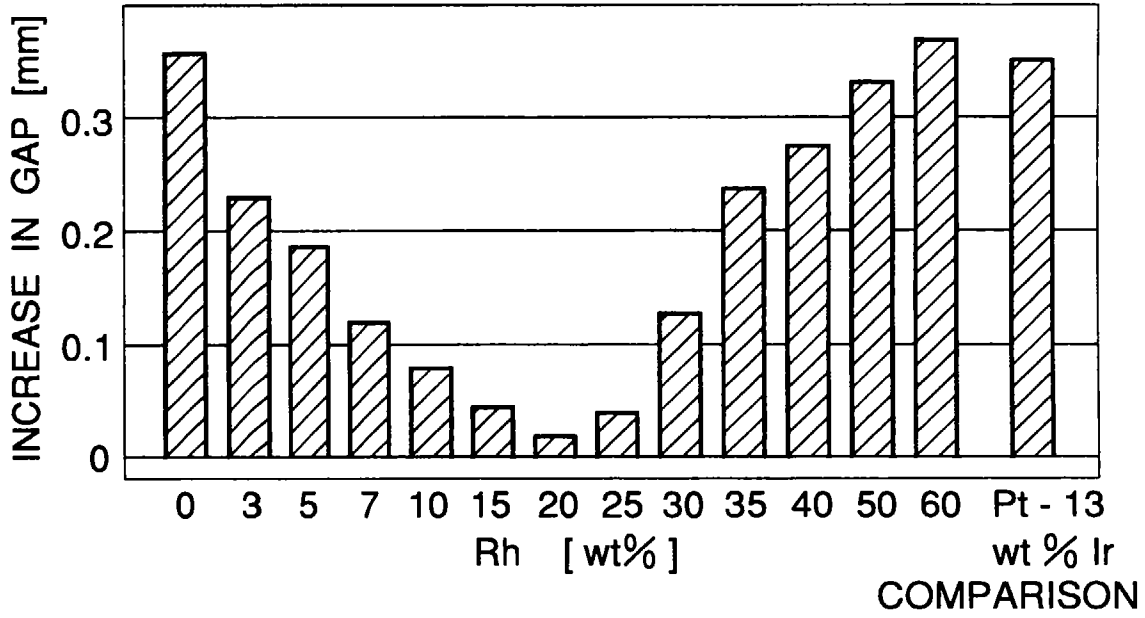

FIG.4

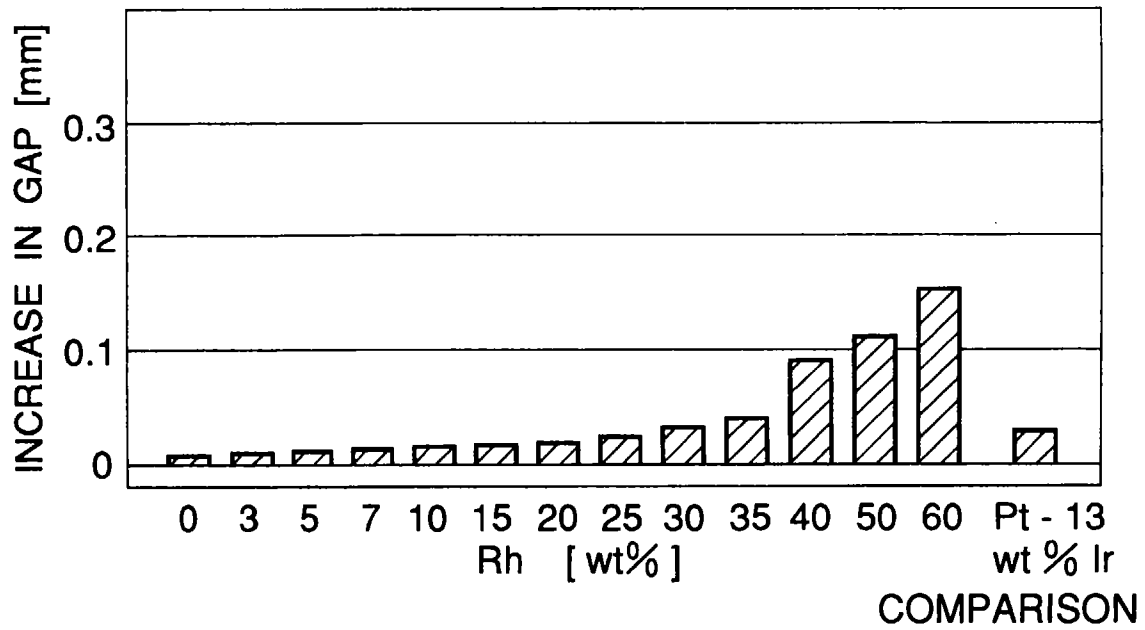
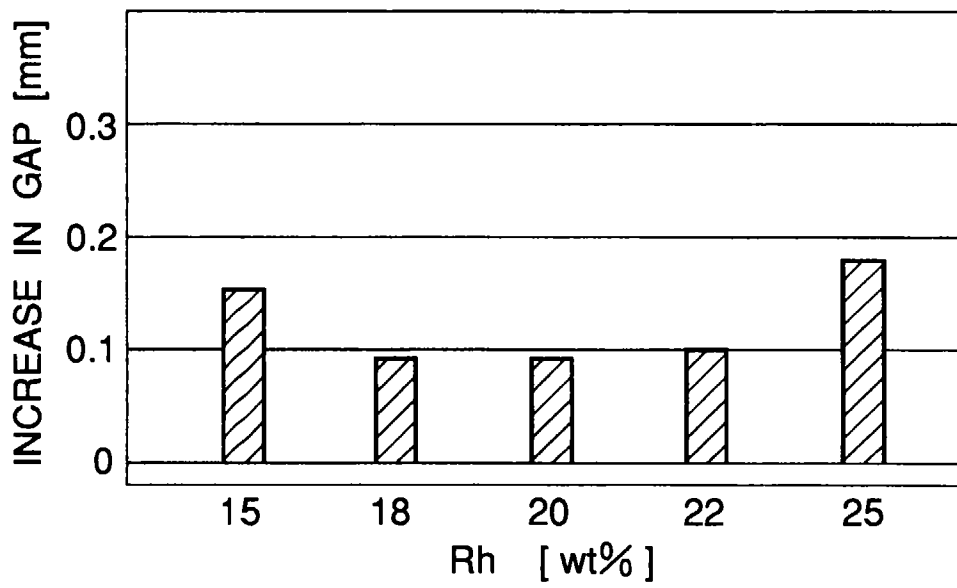

FIG.5





European Patent Office

EUROPEAN SEARCH REPORT

Application Number
EP 97 11 0583

DOCUMENTS CONSIDERED TO BE RELEVANT			
Category	Citation of document with indication, where appropriate, of relevant passages	Relevant to claim	CLASSIFICATION OF THE APPLICATION (Int.Cl.6)
A	EP 0 243 529 A (NGK SPARK PLUG CO) 4 November 1987 * claim 3 *	1	H01T13/39
P,X	GB 2 302 367 A (NIPPONDENSO CO) 15 January 1997 * the whole document *	1	
			TECHNICAL FIELDS SEARCHED (Int.Cl.6)
			H01T
The present search report has been drawn up for all claims			
Place of search		Date of completion of the search	Examiner
THE HAGUE		30 September 1997	Bijn, E
CATEGORY OF CITED DOCUMENTS			
X : particularly relevant if taken alone Y : particularly relevant if combined with another document of the same category A : technological background O : non-written disclosure P : intermediate document		T : theory or principle underlying the invention E : earlier patent document, but published on, or after the filing date D : document cited in the application L : document cited for other reasons & : member of the same patent family, corresponding document	

EPO FORM 1503 03/82 (F04C01)