



(12) EUROPEAN PATENT APPLICATION

(43) Date of publication:
28.01.1998 Bulletin 1998/05

(51) Int. Cl.⁶: F01K 21/04

(21) Application number: 97200464.2

(22) Date of filing: 17.02.1997

(84) Designated Contracting States:
AT BE CH DE DK ES FI FR GB GR IE IT LI LU MC
NL PT SE

• Van Liere, Jacobus
NL 6865 ES Doorwerth (NL)

(30) Priority: 22.07.1996 EP 96202076

(74) Representative:
Prins, Hendrik Willem
Arnold & Siedsma,
Advocaten en Octrooigemachtigden,
Sweelinckplein 1
2517 GK Den Haag (NL)

(71) Applicant: N.V. Kema
6812 AR Arnhem (NL)

(72) Inventors:
• Van der Burgt, Maarten Johannes
NL 1921 BP Akersloot (NL)

(54) System for power generation

(57) The invention relates to a system for power generation comprising a turbine system and a power generating system connected to said turbine system, wherein the said turbine system comprises:

- a) a compressor means (2) provided with an inlet for oxygen-containing gas, an outlet for compressed oxygen-containing gas and inlet means (7) for supplying fluid to said compressor means for cooling the said oxygen-containing gas;
- b) a combustion means (11) provided with a non-gaseous fuel inlet and a flue gas outlet, said com-

bustion means being connected with the said outlet for compressed oxygen-containing gas of the said compressor means;

- c) a gas turbine means (9) connected with said flue gas outlet of the said combustion means and being provided with an outlet for exhaust gases;
- d) a recuperator means (17) connected with 1 the said outlet for compressed oxygen-containing gas of the said compressor means and 2 the said outlet for exhaust gases of the said gas turbine means, for mutual heat exchange.

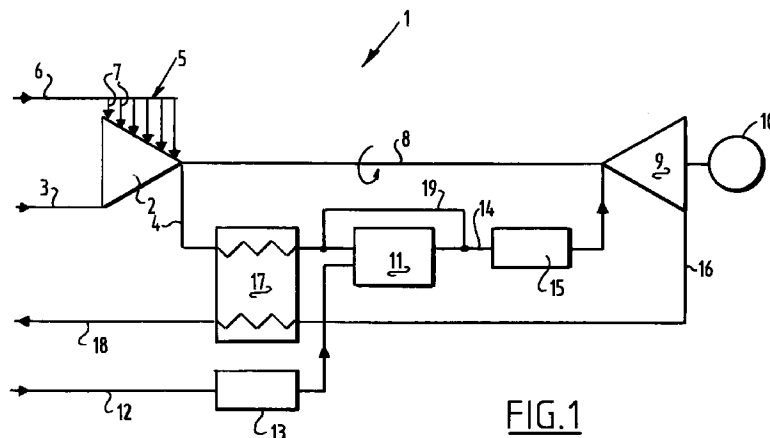

Description

The present invention relates to a system for power generation from non-gaseous fuels. Such systems generally comprise a turbine system, comprising both gas turbines and steam turbines, and a power generating system. At present the efficiency of the best known systems for power generation from non-gaseous fuels is about 40 -45 %. In such systems for power generation there is a need to improve their performance and their efficiency. It is an object of the present invention to provide a system for power generation having an increased efficiency, in particular above 45% and more in particular 46-52%.

The invention therefore provides a system for power generation from non-gaseous fuels comprising a turbine system and a power generating system connected to said turbine system, wherein the said turbine system comprises:

- a) a compressor means provided with an inlet for oxygen-containing gas, an outlet for compressed oxygen-containing gas and inlet means for supplying fluid to said compressor means for cooling the said oxygen-containing gas;
- b) a combustion means provided with a non-gaseous fuel inlet and a flue gas outlet, said combustion means being connected with the said outlet for compressed oxygen-containing gas of the said compressor means;
- c) a gas turbine means connected with said flue gas outlet of the said combustion means and being provided with an outlet for exhaust gases;
- d) a recuperator means connected with 1 the said outlet for compressed oxygen-containing gas of the said compressor means and 2 the said outlet for exhaust gases of the said gas turbine means, for mutual heat exchange;

In an advantageous embodiment of the present invention the fluid is supplied directly to the oxygen-containing gas in and/or after the compressor means and the cooling is essentially obtained by evaporation of the fluid.

Further, advantageously, the exhaust gas from the gas turbine means is expanded to a sub-atmospheric pressure of 0.2 - 0.8 bara.

In another advantageous embodiment the exhaust gases leaving the gas turbine means are cooled and water is condensed out.

In another advantageous embodiment of the invention at least part of the exhaust gas from said gas turbine means is recycled to the inlet of the oxygen-containing gas of said compressor means.

Still more advantageously, at least part of the exhaust gas from the gas turbine means is used to supply heat for drying of the fuel in a drier.

Advantageously an organic fuel is used in said

power generating system.

Advantageously the flue gas outlet of the combustion means passes through a gas cleaning means.

Further advantageously the flue gas is cleaned in the combustion means.

More advantageously the exhaust gases leaving the gas turbine means are cleaned.

Still more advantageously the exhaust gases routed to the stack are cleaned.

Advantageously part of the heat developed in the power generating system is used for heating purposes.

More advantageously the condensation takes place in two consecutive steps.

The present invention will now be described in more detail by way of example by reference to the accompanying drawings, in which:

Fig.1 represents schematically a power generation system according to the present invention;

Fig.2 represents schematically an advantageous embodiment of the present invention;

Fig.3 represents schematically another advantageous embodiment of the present invention; and

Fig.4 represents schematically still another advantageous embodiment of the present invention.

The drawings show in:

Fig. 1-4 flow sheets of power stations according to the present invention.

Fig. 1 shows a power station 1 according to the present invention. This power station 1 comprises a compressor unit 2 for quasi-isothermal compression. The compressor unit 2 comprises an oxygen-containing gas inlet 3 and a compressed outlet for oxygen-containing gas 4. The compressor unit 2 is further provided with means 5 for direct water cooling of oxygen-containing gas in the compressor unit. Thereto the means 5 comprise a water inlet 6 and waterpipes 7. Furthermore, it is possible to supply water into the compressed oxygen-containing gas outlet 4.

The compressor unit 2 is mounted on a shaft 8 to which is connected a turbine 9 and a generator 10.

The compressed oxygen-containing gas outlet 4 is connected to a combustion means 11 to which is also added fuel via a fuel inlet 12 via a fuel pressurizing device 13. This fuel is non-gaseous and therefore may consist of particulate fuel, liquid fuel and/or mixtures thereof.

The flue gas outlet 14 of the combustion unit 11 is provided with a flue gas cleaning unit 15. Subsequently the flue gas is expanded in the turbine 9 and the exhaust gas leaves the turbine 9 via the turbine exhaust gas outlet 16. This outlet 16 passes through a recuperator 17 for heat exchange with compressed oxygen-containing gas that passes through the recuperator 17 via the compressed oxygen-containing gas outlet 4 of the compressor means 2. Finally the cooled exhaust gas is routed to a stack via duct 18.

It is noted that a by-pass line 19 may be arranged over the combustion and/or cleaning unit providing an opportunity to control the combustion and/or the turbine temperature.

Fig. 2 shows a power station 20 of which unit operations and processes similar to those of the power station 1 of Fig. 1 are referred to by using the same reference numbers. In power station 20 the compressor means 2 comprises two consecutive compressors 21 and 22 for compressing oxygen-containing gas to respectively 0,8 bara and 8 bara. After each oxygen-containing compression stage water is directly injected for cooling and to that end the direct water cooling means 5 comprise water inlets 23 and 24.

In this case the fuel supplied via the fuel inlet 12 consists of coal which is combusted at a low pressure of 8 bara and slash is removed from the combustion means 11 via the slash outlet 25. In this case the combustion means may consist of a fluidized bed. Cooled flue gas is routed via duct 18 to a stack 32. The efficiency of the power station 20 is about 48.0%. Finally it is noted that the shaft 8 and the generator 10 are omitted for reasons of clarity.

Fig. 3 shows a power station 26 having a lay-out similar to the power station 20 of Fig. 2. Same or equivalent operation units and processes as for the power station 20 are referred to by the same reference numbers in Fig. 2.

The power station 26 is provided with a subatmospheric expansion turbine means 27 expanding exhaust gas to a subatmospheric pressure of about 0.5 bara. This flue gas passes through the recuperator 17 and subsequently through a condenser unit 28. In the condenser unit 28 heat and condensate are removed in a cooler 29 and a condenser 30 respectively. The cooler 29 may be substituted for another condenser such that two types of condensate may be obtained of which the condensate originating from the condenser 30 is the most pure.

Subsequently, the dry cool exhaust gas is compressed in a compressor 31 to atmospheric pressure and subsequently released into the atmosphere via the stack 32.

The power station efficiency is about 50%.

Finally, Fig. 4 shows a power station 33 for firing wet biomass. The lay-out of this power station 33 is similar to the power station 20 of Fig. 2 and similar or equivalent unit operations and processes are referred to by the same reference numbers.

Wet biomass supplied via the biomass inlet 12 is first dried in a biomass dryer 34 using the low temperature heat (about 140°C) of the exhaust gas leaving the recuperator 16 via the outlet 35. The dry and heated (110°C) biomass is fed via a pressurizing device 13 to the combustion unit 11. Any combustion ash is removed from the flue gas cleaning unit 15 via the outlet 36.

The power station efficiency is dependent on the operation parameters about 50 to 54%.

It will be appreciated that various modifications of the present invention will be apparent to those skilled in the art from the foregoing description. Such modifications are intended to fall within the scope of the appended claims.

Claims

1. A system for power generation comprising a turbine system and a power generating system connected to said turbine system, wherein the said turbine system comprises:
 - a) a compressor means provided with an inlet for oxygen-containing gas, an outlet for compressed oxygen-containing gas and inlet means for supplying fluid to said compressor means for cooling the said oxygen-containing gas;
 - b) a combustion means provided with a non-gaseous fuel inlet and a flue gas outlet, said combustion means being connected with the said outlet for compressed oxygen-containing gas of the said compressor means;
 - c) a gas turbine means connected with said flue gas outlet of the said combustion means and being provided with an outlet for exhaust gases;
 - d) a recuperator means connected with 1 the said outlet for compressed oxygen-containing gas of the said compressor means and 2 the said outlet for exhaust gases of the said gas turbine means, for mutual heat exchange;
2. The system as claimed in claim 1 wherein said fluid is directly supplied to the oxygen-containing gas in and/or after the compressor means and the cooling is essentially obtained by evaporation of said fluid.
3. The system as claimed in any of claims 1-2, wherein the said exhaust gases from the said gas turbine means are expanded to a sub-atmospheric pressure of 0.2 - 0.8 bara.
4. The system as claimed in any of the claims 1-3, wherein the exhaust gases leaving the gas turbine system are cooled and water is condensed out.
5. The system as claimed in any of the claims 1-4, wherein at least part of the exhaust gas from said gas turbine means is recycled to the said inlet for oxygen-containing gas of said compressor means.
6. The system as claimed in any of the claims 1-5, wherein the fuel is dried in a dryer for which the heat required is taken from the exhaust gas from the gas turbine means.

7. The system as claimed in any of the claims 1-6, wherein the non-gaseous fuel is an organic material.
8. The system as claimed in any of the claims 1-7, wherein the flue gas outlet of the combustion passes through a gas cleaning unit. 5
9. The system as claimed in any of the claims 1-8, wherein the gas is cleaned during combustion. 10
10. The system as claimed in any of the claims 1-9, wherein the exhaust gases are cleaned after leaving the gas turbine means. 15
11. The system as claimed in any of the claims 1-10, wherein the exhaust gases which are routed to the stack are cleaned.
12. The system as claimed in any of the claims 1-11, wherein part of the heat developed in the power generating system is applied for heating purposes. 20
13. The system as claimed in any of the claims 1-12, condensation takes place in two consecutive steps. 25

30

35

40

45

50

55

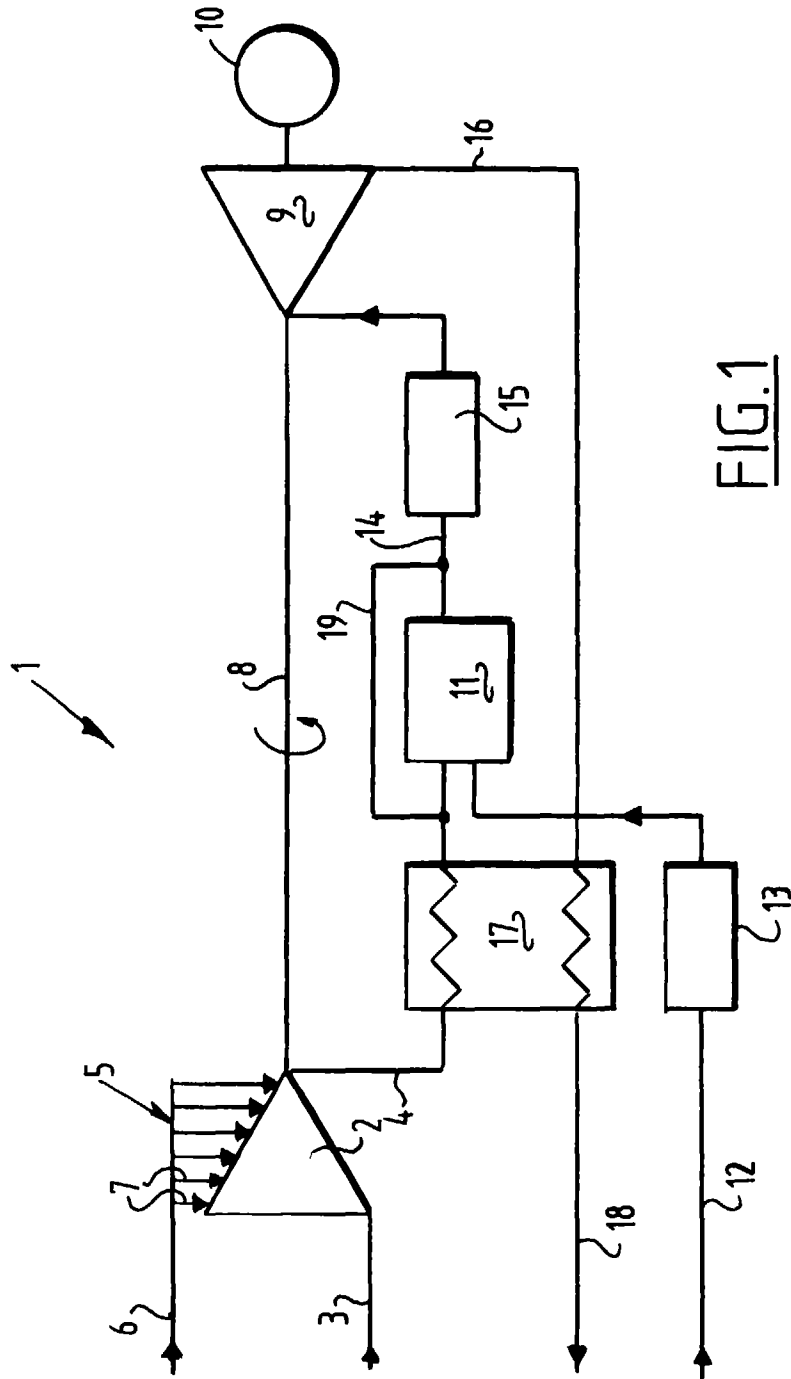

FIG. 1

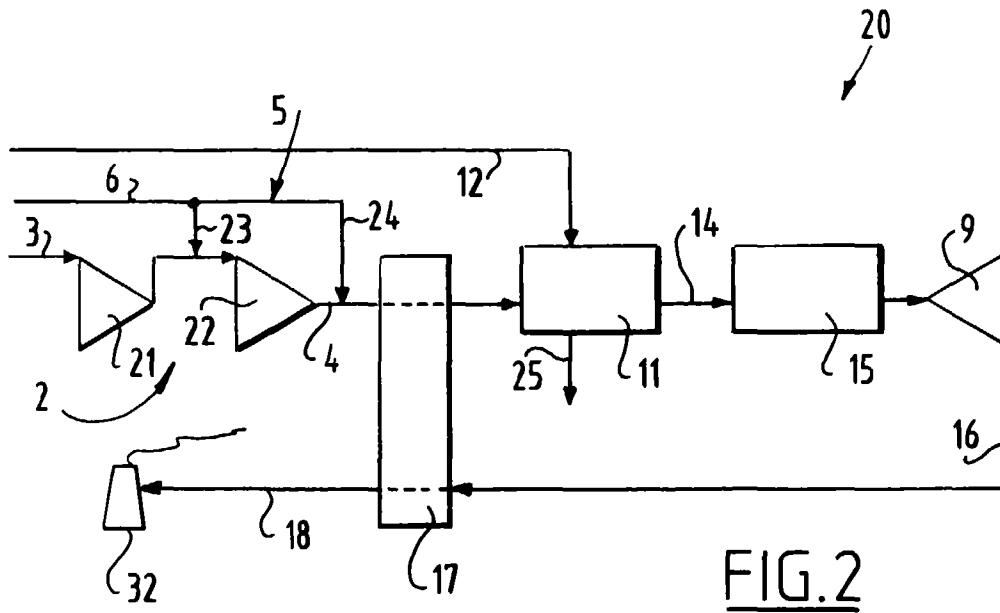

FIG. 2

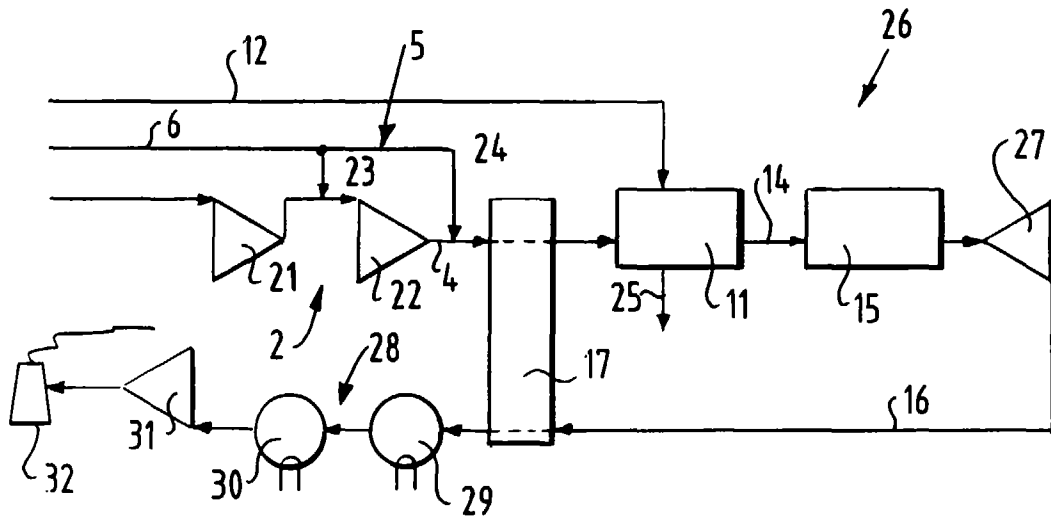

FIG. 3

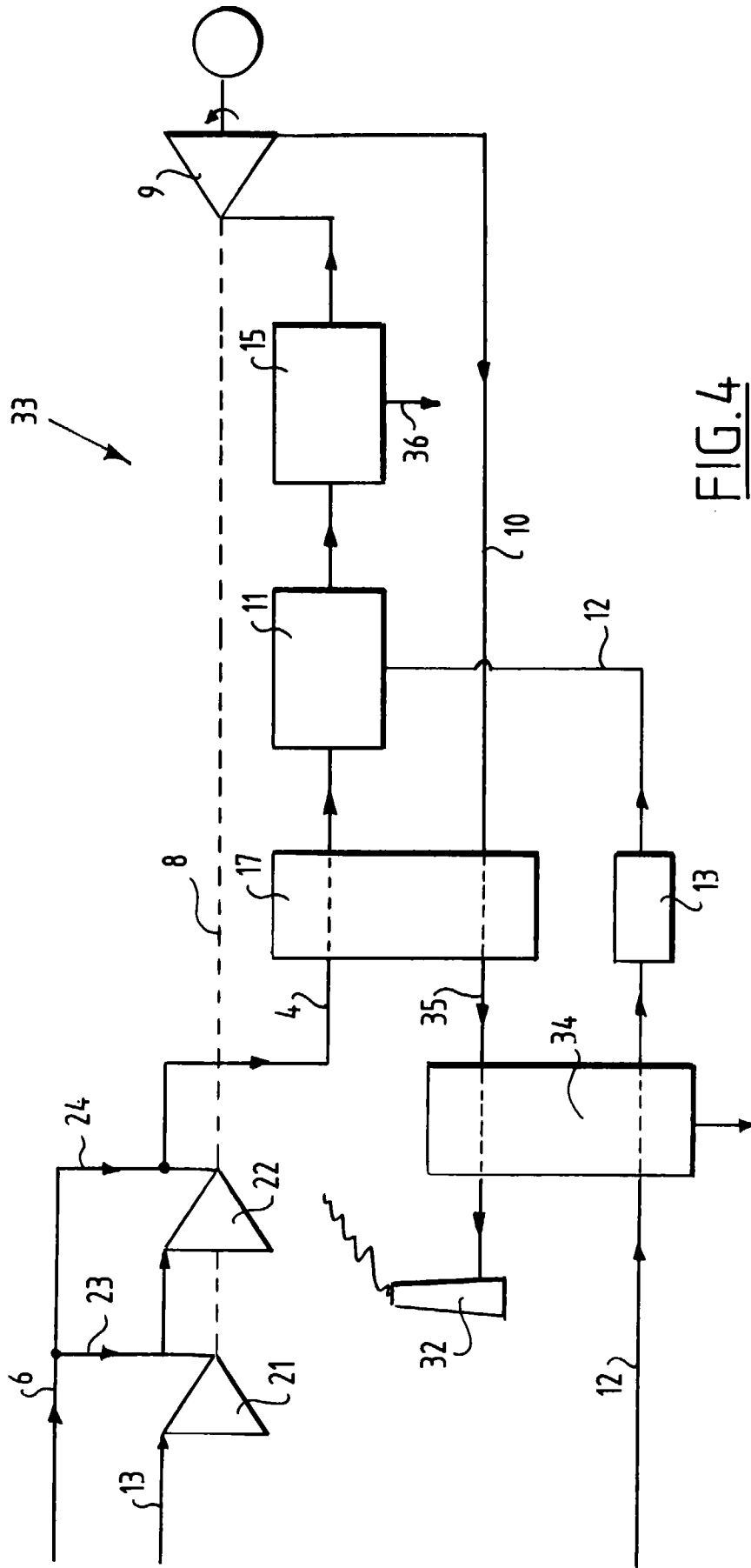

FIG. 4



European Patent
Office

EUROPEAN SEARCH REPORT

Application Number
EP 97 20 0464

DOCUMENTS CONSIDERED TO BE RELEVANT			
Category	Citation of document with indication, where appropriate, of relevant passages	Relevant to claim	CLASSIFICATION OF THE APPLICATION (Int.Cl.6)
X	EP 0 444 913 A (TURBINE DEVELOPMENTS) * page 5, line 30 - page 6, line 37 * * page 13, line 9 - line 10; figures * ---	1,2	F01K21/04
X	EP 0 361 065 A (WESTINGHOUSE) * column 4, line 45 - column 5, line 52; figure 1 * ---	1,2,8,9	
A	US 4 893 469 A (YAMASHITA) * the whole document * ---	1,2,4,7	
A	GB 1 284 335 A (ROLLS-ROYCE) * page 2, line 3 - line 107; figure 1 * ---	1,3,4	
A	GB 1 056 722 A (SQUIRES) * page 2, line 115 - page 3, line 22; figure 1 * ---	3,5,13	
A	EP 0 602 795 A (FOSTER WHEELER) * column 4, line 29 - line 46; figure 1 * ---	4,6,11	
A	EP 0 384 336 A (GAIA MARIO) * column 3, line 12 - column 5, line 48; figures * ---	3,4,10, 11	TECHNICAL FIELDS SEARCHED (Int.Cl.6) F01K
A	US 5 067 317 A (KASPER) * abstract; figure 1 * ---	4,8,9	
A	DE 43 35 136 A (EVT) * column 2, line 23 - column 3, line 63; figures * -----	5,8,10, 11	
The present search report has been drawn up for all claims			
Place of search THE HAGUE		Date of completion of the search 9 October 1997	Examiner Van Gheel, J
CATEGORY OF CITED DOCUMENTS X : particularly relevant if taken alone Y : particularly relevant if combined with another document of the same category A : technological background O : non-written disclosure P : intermediate document		T : theory or principle underlying the invention E : earlier patent document, but published on, or after the filing date D : document cited in the application L : document cited for other reasons & : member of the same patent family, corresponding document	

EPO FORM 1503 03/92 (P04C01)