



Europäisches Patentamt
European Patent Office
Office européen des brevets



(11) EP 0 822 295 A1

(12) **EUROPEAN PATENT APPLICATION**
published in accordance with Art. 158(3) EPC

(43) Date of publication:
04.02.1998 Bulletin 1998/06

(51) Int. Cl.⁶: E02D 3/10

(21) Application number: 96909391.3

(86) International application number:
PCT/KR96/00054

(22) Date of filing: 15.04.1996

(87) International publication number:
WO 96/33313 (24.10.1996 Gazette 1996/47)

(84) Designated Contracting States:
BE DE DK ES FI FR GB GR IE IT LU MC NL PT SE
Designated Extension States:
AL LT LV SI

(72) Inventor: Kim, Jong Chun
Cheju-City, Cheju-do 690-042 (KR)

(30) Priority: 15.04.1995 KR 1995891
11.05.1995 KR 1995115

(74) Representative:
Sama, Daniele, Dr.
Sama Patents
Via Morgagni, 2
20129 Milano (IT)

(71) Applicant: Kim, Jong Chun
Cheju-City, Cheju-do 690-042 (KR)

(54) **DRAIN FORMING EQUIPMENT FOR REINFORCING SOFT GROUND, AND METHOD AND STRUCTURE FOR ARRANGING DRAINS**

(57) Disclosed is a drain structure and an arrangement method thereof for reinforcing a soft ground, and the apparatuses which are used in the formation of the drain. The invention provides a drain pack having a net portion and a reinforcement portion as well as a rectangular drain pack. Also, the invention provides a drain structure and an arrangement method in which an effective draining radius is uniform. As well, the invention provides a polygonal guide casing for burying the pack underground without any twisting of the pack, and a driving apparatus for installing perpendicularly the drain into the highest depth of a soft ground without any distortion of the guide casing. Thus, a drain arranging method and apparatuses for forming the drain maximize a draining effect and expedite fast ground sink.

FIG. 4 A

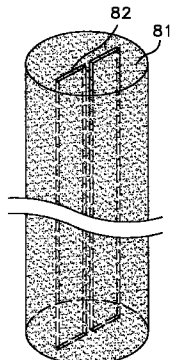
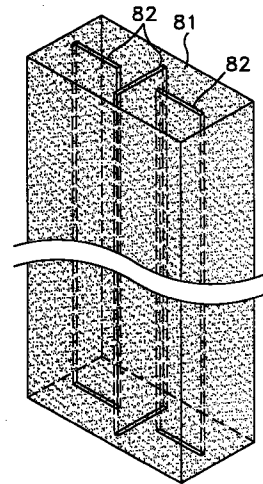

FIG. 4 B



EP 0 822 295 A1

Description

TECHNICAL FIELD

The present invention relates to a technology of reinforcing soft grounds, and more particularly to a pack for molding a sand pile to form a drain, a pack guide casing for driving a pack underground, a pack file driving apparatus which is used for driving a pack into a guide casing, and a drain structure and an alignment method thereof.

BACKGROUND ART

A vertical draining method such as a flexible sand drain and/or a paper drain is generally used for reinforcing a soft ground. A conventional vertical draining method drives a cylindrical guide casing underground, inserts a sand pack or a paper drain board into the guide casing, and then removes the guide casing. FIG. 1 is a perspective view of a flexible sand pack and a guide casing which are used for a conventional vertical draining method. As shown in FIG. 1, the conventional vertical draining method is accomplished by burying a cylindrical guide casing 10 underground, and then inserting a sand pile molding pack 20 into guide casing 10. The pack 20, which comprises a mesh-type texture, is formed by overlapping two sheets of the mesh-type textures such that side portions of these sheets form reinforcement portions 31 and 32 extending lengthwise by connecting both ends or thermally melting them to attach to each other. Pack 20 inserted into guide casing 10 is filled with sand, and then guide casing 10 is removed at the sand-filled state to form a drain.

However, the conventional sand pile molding pack has problems that the manufacturing method is complicated and the manufacturing cost is high. Also, the conventional molding packs are susceptible to breakage or cut-off, or some discrepancy between latitude and longitude. Further, the conventional pack has a problem that the reinforcement portion 31 or 32 is folded, such that a fine soil cannot pass, and a film is formed which lowers a draining effect. Also, since the conventional flexible drain is in a cylindrical shape and the diameter of the drain is limited to a range within 25cm, a draining contact area is small which lowers a draining effect.

The conventional guide casing is formed as only a cylindrical shape, to accordingly raise a phenomenon of twisting the pack when the pack is inserted. Moreover, since the paper drain board is a structure of a thin plate when the paper drain is formed, many spaces are formed therein. Thus, removal of the casing causes an excessive ground movement.

DISCLOSURE OF THE INVENTION

Therefore, to solve the above problems, it is an object of the present invention to provide a sand pile

molding pack with a simple manufacturing process and a low manufacturing cost.

Another object of the present invention is to provide a sand pile molding pack comprising a reinforcement portion in which an electric conductor is incorporated.

Yet another object of the present invention is to provide a polygonal sand pile molding pack.

Still another object of the present invention is to provide a pack in which a flexible sand drain and a paper drain are simultaneously installed.

Still yet another object of the present invention is to provide a pack guide member in which a pack is not twisted to each other.

A further object of the present invention is to provide a drain including sand and a reinforcement member for draining acceleration that is buried in sand.

A yet further object of the present invention is to provide a device for dropping a reinforcement member.

A still further object of the present invention is to provide a guide casing which can prevent its bending when buried underground.

A still yet further object of the present invention is to provide a casing comprising an internal reinforcement member.

Yet another object of the present invention is to provide a drain structure and an arrangement method thereof in which a draining effect is high.

Still yet another object of the present invention is to provide a pile driver for supplying a pack to be driven into a guide casing, so as to form a plurality of drains being in a rectangular shape.

To accomplish the above objects of the present invention, there is provided a pack which is used for reinforcing a soft ground according to an aspect of the present invention, wherein the pack is fabricated via an injection molding.

A drain for reinforcing a soft ground according to one feature of the present invention comprises sand buried underground; and at least one or more reinforcement members for draining acceleration which is buried in the sand.

A dropping device of reinforcement members according to another feature of the present invention comprises a casing, including space inside for receiving a reinforcement member for draining acceleration and forming a predetermined size of piercing holes at the top and bottom thereof; and a fastening member, disposed at the outer of the piercing holes of the casing, by which one end of the reinforcement portion is fastened.

A guiding pack which is used for reinforcing a soft ground according to yet another feature of the present invention comprises a first member which is formed with a hollow shape of a polygonal body having a predetermined length; and a second member which is connected in the lower end of the pack and connected to the hollow inside of the first member, having the same angle as the first member, to be movable up and down.

A guide casing for forming a drain which is used for

reinforcing a soft ground according to still another feature of the present invention comprises a body, formed in a hollow shape having a predetermined length; and at least one or more reinforcement members which protrudes in the body.

A drain structure for reinforcing a soft ground according to still yet another feature of the present invention, is characterized by the fact that the drain structure is in a rectangular shape.

A drain arrangement method for reinforcing a soft ground according to a further feature of the present invention comprises the steps of maintaining a virtual line which connects a center line of each of four rectangular drains adjacent to each other to form a square, and arranging a longitudinal axis of each drain perpendicular to the longitudinal axis of an adjacent drain at the center.

A driving apparatus for forming a drain according to a yet further feature of the present invention comprises:

a guide bar, installed lengthwise; a driving member, connected to the guide bar; a driving block, installed in the lower end of the driving member; a square holding plate which is fixed to the driving block and is in a rectangular form; a plurality of guide casing which is fixed to the holding plate and arranged according to the above-described arrangement method; and a reinforcement connection plate for connecting the guide casings to each other.

BRIEF DESCRIPTION OF THE DRAWINGS

FIG. 1 is a perspective view of a conventional flexible pack and guide casing for explaining a vertical draining method.

FIGs. 2A through 2C are views explaining a sand pile molding pack according to one embodiment of the present invention.

FIGs. 3A through 3F are plan views of a sand pile molding pack according to another embodiment of the present invention.

FIGs. 4A and 4B are perspective views of a drain according to embodiments of the present invention.

FIGs. 5A and 5B are perspective views showing a weight material which is used for dropping a reinforcement member for draining acceleration when forming a drain

FIG. 6 is a perspective view showing a dropping device of a reinforcement member for draining acceleration according to one embodiment of the present invention.

FIG. 7 is a perspective view of a guide casing according to one embodiment of the present invention.

FIG. 8 is a plan view of a guide casing according to another embodiment of the present invention.

FIGs. 9A through 9D are plan views of guide casings according to yet another embodiment of the

present invention.

FIG. 10 is a plan view of a plurality of integrally constructed guide casings to embody a drain arranging method according to the present invention.

FIG. 11 is a conceptual view for explaining a drain arranging method according to the present invention.

FIG. 12A is a front view of a driving apparatus according to the present invention, and FIG. 12B is a cross-sectional view taken along a direction of I-I of FIG. 12A.

FIG. 13A is a perspective view of a conventional flexible drain and FIG. 13B is a perspective view of a drain structure according to the present invention.

BEST MODE FOR CARRYING OUT THE INVENTION

Hereinbelow, preferred embodiments of the present invention will be described in detail with reference to the accompanying drawings.

FIGs. 2A through 2C are views explaining a sand pile molding pack according to one embodiment of the present invention. The pack of the present invention is fabricated by a metal injection molding method. FIG. 2A shows a sand pile molding pack material 50 having a reinforcement portion 51 at a constant interval which is obtained by the injection molding. A sand pile molding pack 60 shown in FIG. 2B is obtained by cutting pack material 50 of FIG. 2A to include at least one reinforcement portion 51 and combining the cut pack materials with each other.

FIG. 2C is a cross-sectional view of a reinforcement portion of a sand pile molding pack according to another embodiment of the present invention. The reinforcement portion 51 in this embodiment includes an electric conductor 53 therein, which is for connecting an electrode when applying an electric osmotic method thereto. One electric conductor can be installed for every reinforcement portion 51 of pack 60, or a plurality of conductors can be separately installed in a single reinforcement portion.

FIGs. 3A through 3F are plan views of sand pile molding packs according to yet another embodiments of the present invention. It can be seen that the packs of the present embodiments are extended lengthwise in the same pattern despite no showing perspective views.

FIGs. 3A and 3C show rectangular packs and FIGs. 3D and 3F show cylindrical packs. In these embodiments, the pack includes net portions 71 and a plurality of reinforcement portions 72. The reinforcement portion 72 can be attached to a sub-texture, and then the reinforcement portion 72 attached to the sub-texture is formed to have a bending portion for drain. Thus, the packs according to these embodiments have a merit that a flexible sand drain and a paper drain can be simultaneously formed.

Further, since the pack is in a rectangular shape, a draining area is 30% greater than a cylindrical pack which consumes the same amount of sand as that of

the rectangular pack. That is, the rectangular pack has circumferential length of more than 30% at the same area compared with the cylindrical pack. Thus, an increased draining effect of more than 30% can be obtained, even though the same amount of sand is used.

Furthermore, the conventional flexible pack is continuously produced without any marking in the same shape and color, and then is measured and cut by necessary lengths in use. The drain which is constructed by using such a pack has an exposed portion of the same shape and color. Thus, to ascertain whether the underground drain has been constructed up to a target depth, construction drawings or records should be checked or it should be measured using other equipment.

Thus, the pack of the present invention has markings which can identify the length of the pack. That is, when the pack is produced, various colors or figures are marked on the pack. Alternatively, reinforcement portions having the identified patterns are made and attached to the pack to advantageously permit the identification of the length by human vision. Thus, after construction, identification of the markings of the exposed drain can make a judgement of whether such a construction was properly done. Accordingly, poor construction can be prevented, and easy construction or effective construction control can be performed.

FIGs. 4A and 4B are perspective views of a drain according to embodiments of the present invention. The drain of the present invention includes at least one or more reinforcement members 82 for draining acceleration at the inside of the sand drain 81. A drain board or a suction fiber of water can be used as a reinforcement member 82 for draining acceleration. Thus, this drain can expedite highly drain efficiency and maintain a certain operation for a long-term time, compared with the conventional paper drain or sand drain.

FIGs. 5A and 5B are perspective views of a weight material which is used for dropping a reinforcement member for draining acceleration when forming a drain. The weight material is fabricated with a rigid material such as concrete, each of which forms a certain number of connectors 84 according to the number of the reinforcement member for draining acceleration. Connectors 84 are connected to the bottom of reinforcement member for draining acceleration. The weight materials can be varied according to a shape of the guide casing. Protrusions 86 of FIG. 5A are intended to drop a reinforcement member without occurrence of twist, which are coupled to a guide groove at the inside of the guide casing (not shown).

FIG. 6 is a perspective view showing a dropping device of a reinforcement member for draining acceleration according to one embodiment of the present invention. A dropping unit includes a casing 87, at the top and bottom of which piercing holes 88 and 89 are respectively formed, and also forms a gate 90 capable of opening and shutting for putting in and out reinforce-

ment members. To one end of reinforcement member 82 a fastening member 91 is coupled. Fastening member 91 which is disposed at the outer of the top piercing hole 88 of casing 87, is designed to have a predetermined size not to allow it to pass through piercing holes, and to form the drain by filling with sand after fixing the upper end of the reinforcement member to an inlet for sand. Since fastening member 91 is for combining the ends of reinforcement member 82, the member 91 does not depend on any specific shapes as well as format as shown in the drawing. The other end of reinforcement member 82 is connected to weight material 92 as shown in FIG. 5, so that reinforcement member 82 can be swiftly dropping into the inside of a casing for drain formation through the lower piercing hole 89 without any separate device.

FIG. 7 is a perspective view of a guide casing according to one embodiment of the present invention.

The casing of the present invention is driven by a predetermined depth into a soft ground and comprises a first member 95 having a polygonal body. The casing includes also a second member 96, which is connected to the bottom of pack P, for guiding swiftly pack P into the inside of first member 95. Second member 96 has the same angle as first member 95. Accordingly, when second member 96 is dropped into the inside of first member 95, the twist and distortion of pack P is prevented.

FIG. 8 is a plan view of the guide casing according to another embodiment of the present invention. As shown in FIG. 8, guide casing 100 in this embodiment is integrated with at least one or more reinforcement members 101. The reinforcement member 101 is for bending a paper drain board 102 and guiding it into the inside of casing 100 or preventing the bending of a casing. It is more preferable that paper drain board 102 is made of easily bendable materials at the portions which are shown as dotted lines. As described above, since paper drain board 102 is bent and installed by reinforcement member 101, a wider drain board can be driven with a smaller cross-sectional area than in the linearly installed case. Accordingly, a draining effect is largely enhanced and the ground movement is reduced when driven.

FIGs. 9A through 9D are plan views of guide casings according to different embodiments of the present invention. As shown in FIGs. 9A through 9D, guide casings 110 in these embodiments have at least one outer protrusion 111, respectively. Such protrusions 111 are to prevent bending of guide casings 110 when guide casings 110 are buried underground, respectively. In particular, FIG. 9A is a plan view of guide casings 110 consisted of a H-type steel. Here, an intermediate member of H-type steel plays a part of a reinforcement member 101.

FIG. 10 is a plan view of the pack guide casings in which a plurality of the pack guide casings are simultaneously buried underground. As can be seen from the

drawing, a plurality of the pack guide casings 160 are mutually connected by first connectors 161. Thus, bending of the casing can be prevented when a plurality of the guide casings are simultaneously driven underground. The dotted lines in the drawing represent second connectors 162 for effectively preventing the bending of the casing.

FIG. 11 is a conceptual view for explaining a drain arranging method according to the present invention. As shown in the drawing, the draining method according to the present invention has processes of maintaining a virtual line which connects a center point of each drain in four rectangular drains adjacent to each other to form a square, and of arranging a longitudinal axis of each drain perpendicular to the longitudinal axis of an adjacent drain at the center. Thus, an effective draining radius is balanced and a ground sink is also expedited since a draining interval is compact.

FIG. 12A is a front view of a driving apparatus according to the present invention, and FIG. 12B is a cross-sectional view taken along a direction of I-I of FIG. 12A. As shown in the drawings, the driving apparatus comprises a guide bar 170, which is vertically installed and to which a driving member 172 is combined.

At the lower end of driving member 172 a driving block 173 is installed, to which an approximately rectangular shape of a holding plate 174 is fixed. To holding plate 174 a plurality of guide casings 175A ~ 175D are fixed, which are connected each other with a reinforcement connection plate 176, to thus prevent distortion of a casing and maintain its vertical state, thereby constructing a drain having the highest depth. On the other hand, a guide 177 is coupled to guide bar 170 and forms a hole that allows guide casings and reinforcement connection plate 176 to pass therethrough, and plays a role of guiding the direction when guide casings are buried underground. Therefore, at the upper end of holding plate 174 according to the driving apparatus, a device for providing sand or a drain board is optionally installed according to use purpose.

FIG. 12B is a cross-sectional view taken along a direction of I-I of FIG. 12A. As can be known in the drawing, the driving apparatus of the present invention provides such a device which can drive simultaneously a plurality of drains according to the arrangement type of drains shown in FIG. 11.

FIG. 13A is a perspective view of a conventional flexible drain. The flexible drain is in a cylindrical shape and the diameter of the cylindrical shape is limited to a the range between 5cm ~ 25cm. The reason why the size of the diameter is limited is a fact that normal draining is not attained if the diameter is less than 5cm, and the flexibility of the drain is inadequate if the diameter is greater than 25cm.

FIG. 13B is a perspective view of a drain structure according to the present invention. The structure of the present invention is in a rectangular shape, in which the rectangular shape should have a length between 5cm

and 25cm in both sides. Thus, the draining solves the inadequacy of the flexibility of the drain. Accordingly, when compared with the conventional apparatus, the present invention provides effects that offers excellent draining, forms a drain with flexibility in horizontal and vertical directions, and increases a draining contact surface area with consumption of a small quantity of sand. That is, under the assumption of the same height in view of the size shown in the drawings, the drains of FIGs. 13A and 13B have nearly the same volume, but the FIG. 13B drain has much larger surface area in view of the circumferential length.

INDUSTRIAL APPLICABILITY

As described above, the present invention provides a new type of technology for reinforcing a soft ground in which the conventional drawbacks are completely supplemented.

Claims

1. A pack which is used for reinforcing a soft ground, wherein said pack is fabricated via an injection molding.
2. The pack according to claim 1, wherein said pack comprises a net portion and at least one or more reinforcement portions.
3. The pack according to claim 2, wherein said reinforcement portion is attached with a sub-texture.
4. The pack according to claims 2, wherein an electric conductor is further provided in the inside of said reinforcement portion.
5. The pack according to one of claims 1 through 4, wherein said pack is in a rectangular shape.
6. The pack according to one of claims 1 through 4, wherein said pack has markings which can be identified with a length.
7. A drain for a soft ground reinforcement comprising:
 - sand buried underground; and
 - at least one or more reinforcement members for draining acceleration which is buried in said sand.
8. The drain for a soft ground reinforcement according to claim 7, wherein further comprising a pack for receiving said sand.
9. The drain for a soft ground reinforcement according to claim 7, wherein said reinforcement member is a drain board.

10. The drain for a soft ground reinforcement according to claim 7, wherein said reinforcement member is a suction fiber of water.
11. A dropping device of a reinforcement member comprising: 5
 a casing, including space inside for receiving a reinforcement member for draining acceleration according to one of claims 7 through 10 and forming a predetermined size of piercing holes at the top and bottom thereof; and 10
 a fastening member, disposed at the outer of the piercing holes of said casing, by which one end of the reinforcement member is fastened. 15
12. The dropping device of a reinforcement member according to claim 11, wherein said casing further comprises a gate capable of opening and shutting for putting in and out said reinforcement member. 20
13. The dropping device of a reinforcement member according to claim 11, further comprising a weight material which is connected to the other end of said reinforcement member. 25
14. The dropping device of a reinforcement member according to claim 13, wherein said weight material has connectors to comply with a shape of the reinforcement member. 30
15. A guide casing for guiding a pack which is used for reinforcing a soft ground, said guide casing comprising: 35
 a first member which is formed with a hollow shape of a polygonal body having a predetermined length; and
 a second member which is connected in the lower end of said pack and connected to the hollow inside of said first member, having the same angle as said first member, to be movable up and down. 40
16. A guide casing for forming a drain which is used for reinforcing a soft ground, said guide casing comprising: 45
 a body, formed in a hollow shape having a predetermined length; and 50
 at least one or more reinforcement members which are placed inside said body.
17. The guide casing according to claim 16, wherein said body further comprises at least one or more protrusions which are protruded to the outer. 55
18. A drain for reinforcing a soft ground characterized by that a drain structure is in a rectangular shape.
19. The drain for reinforcing a soft ground according to claim 18, wherein the rectangular shape has a length between 5cm and 25cm in both sides
20. A drain arrangement method for reinforcing a soft ground comprising the step of maintaining a virtual line which connects a center point of each drain in four rectangular drains adjacent to each other to form a square, and arranging a longitudinal axis of each drain perpendicular to the longitudinal axis of an adjacent drain at the center
21. A driving apparatus for forming a drain comprising:
 a guide bar which is installed lengthwise;
 a driving member which is connected to said guide bar;
 a driving block which is installed at the lower end of said driving member;
 a square holding plate which is fixed to said driving block;
 a plurality of guide casing which is fixed to said holding plate and arranged according to an arrangement method described in claim 20; and
 a reinforcement connection plate for connecting said guide casings to each other.
22. The driving apparatus according to claim 21, wherein further comprises a guide which is fixed to said guide bar, includes a groove to allow said guide casing and said reinforcement connection plate to be passed therethrough.

FIG. 1

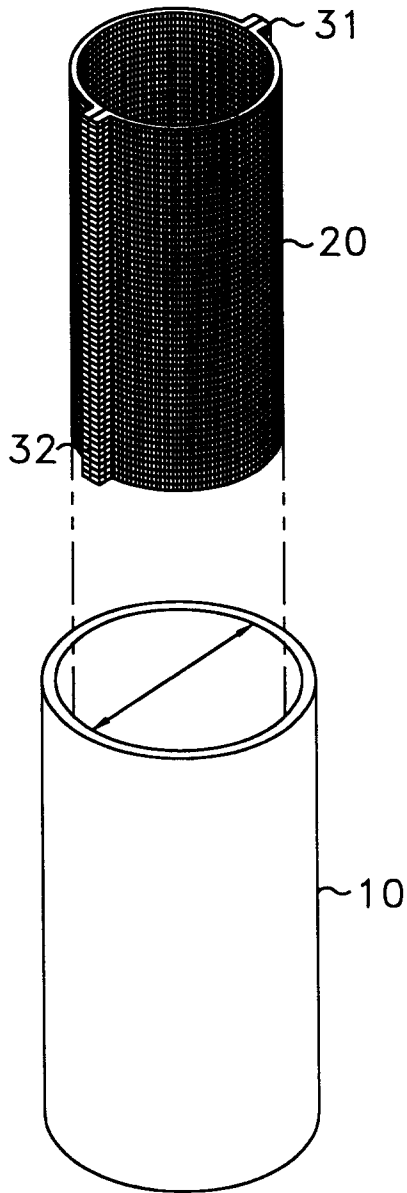

FIG. 2A

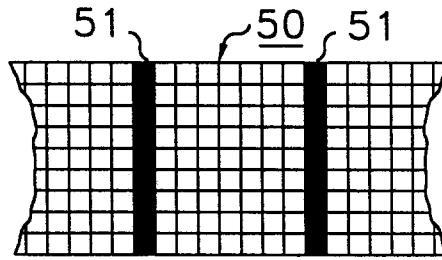

FIG. 2B

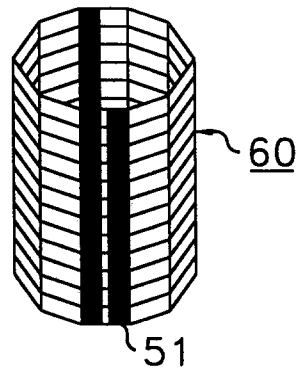

FIG. 2C

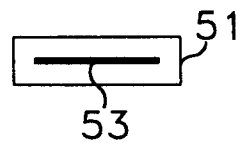

FIG.3A

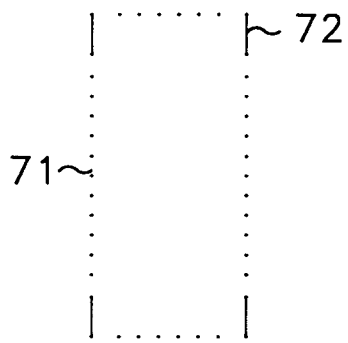

FIG.3B

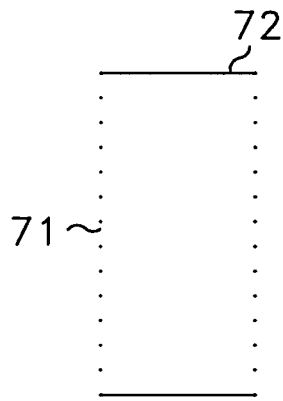

FIG.3C

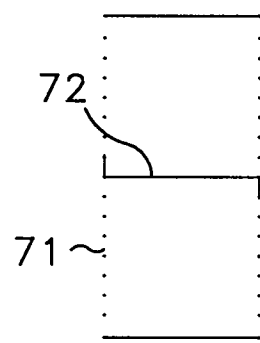

FIG.3D

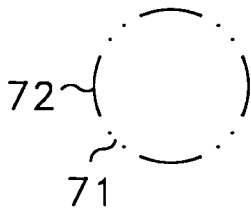

FIG.3E

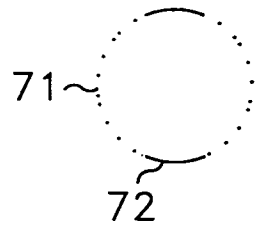

FIG.3F

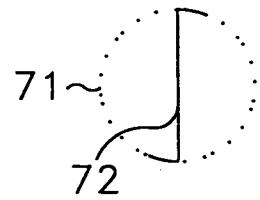

FIG. 4 A

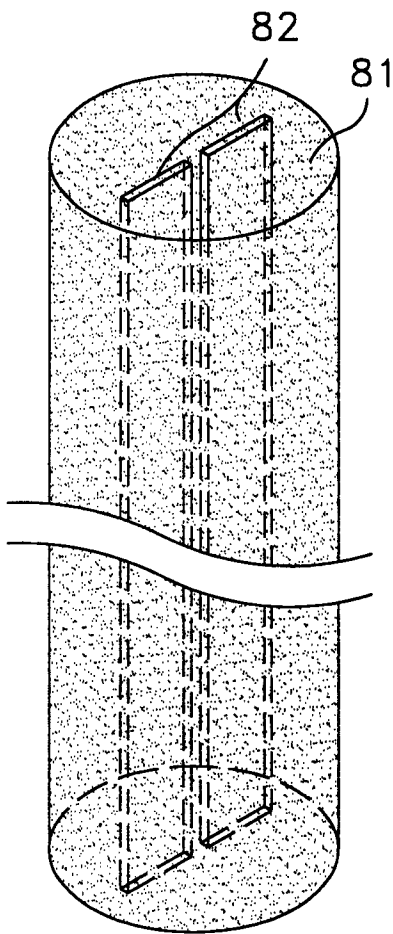

FIG. 4 B

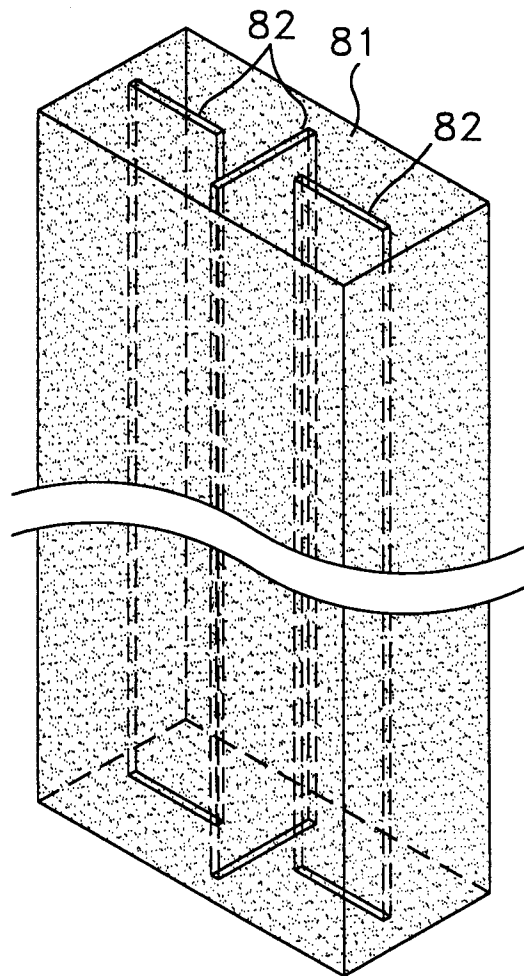

FIG. 5 A

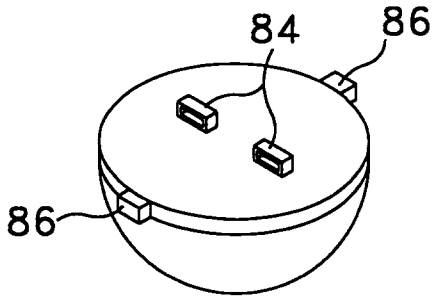
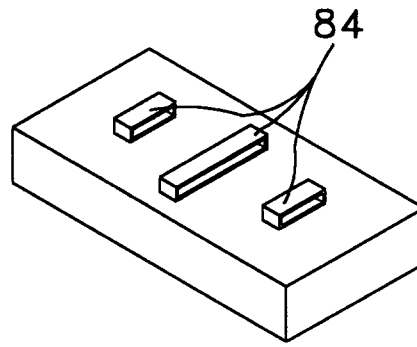

FIG. 5 B



84

FIG. 6

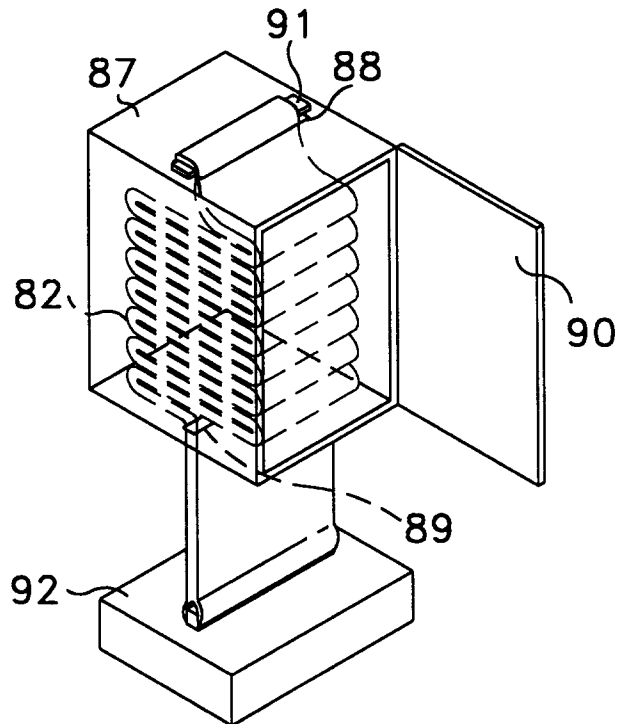

FIG. 7

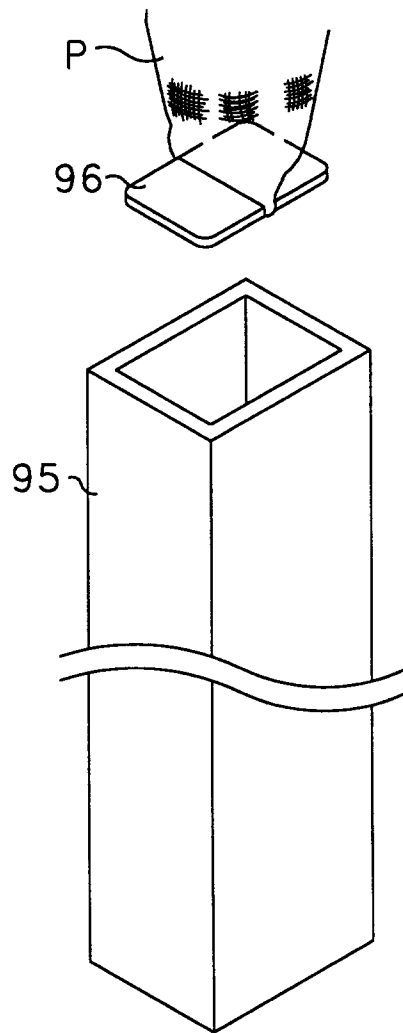

FIG. 8

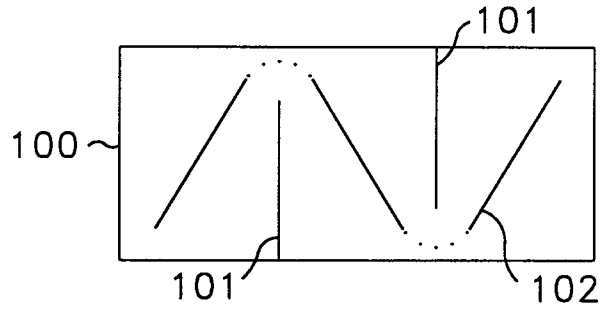

FIG. 9A

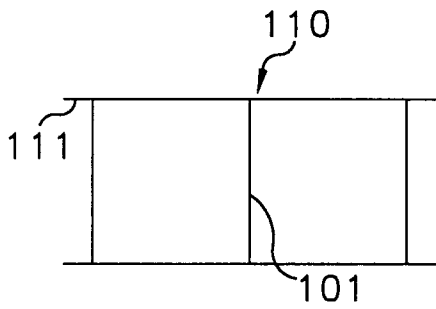

FIG. 9B

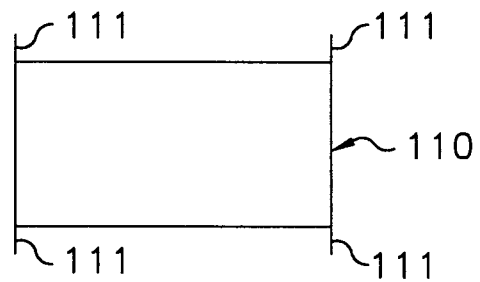

FIG. 9C

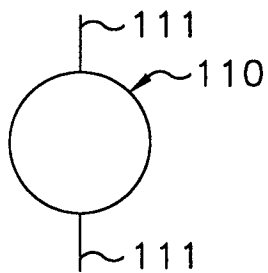

FIG. 9D

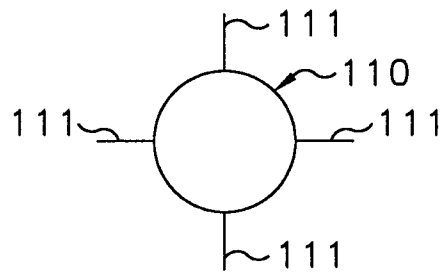

FIG.10

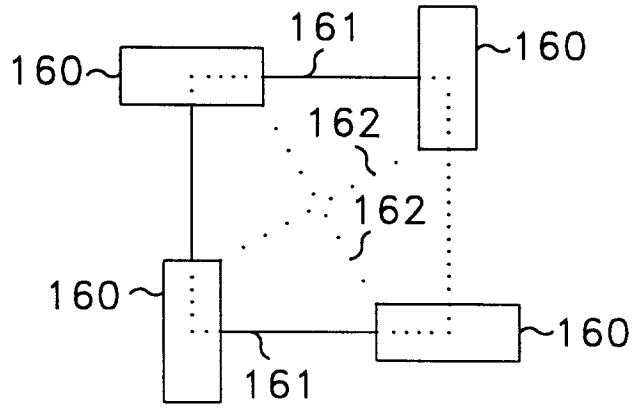

FIG.11

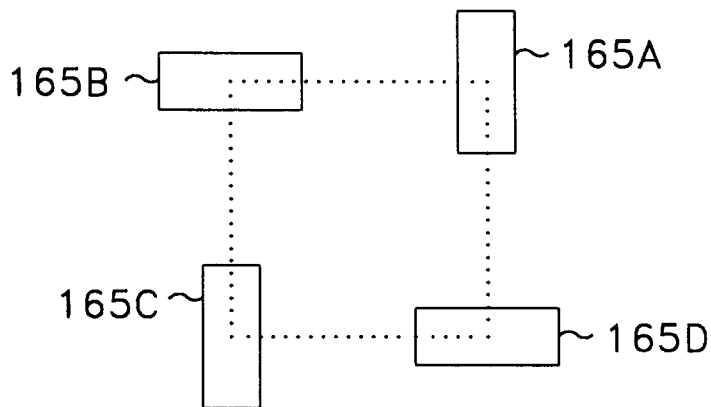

FIG.12 A

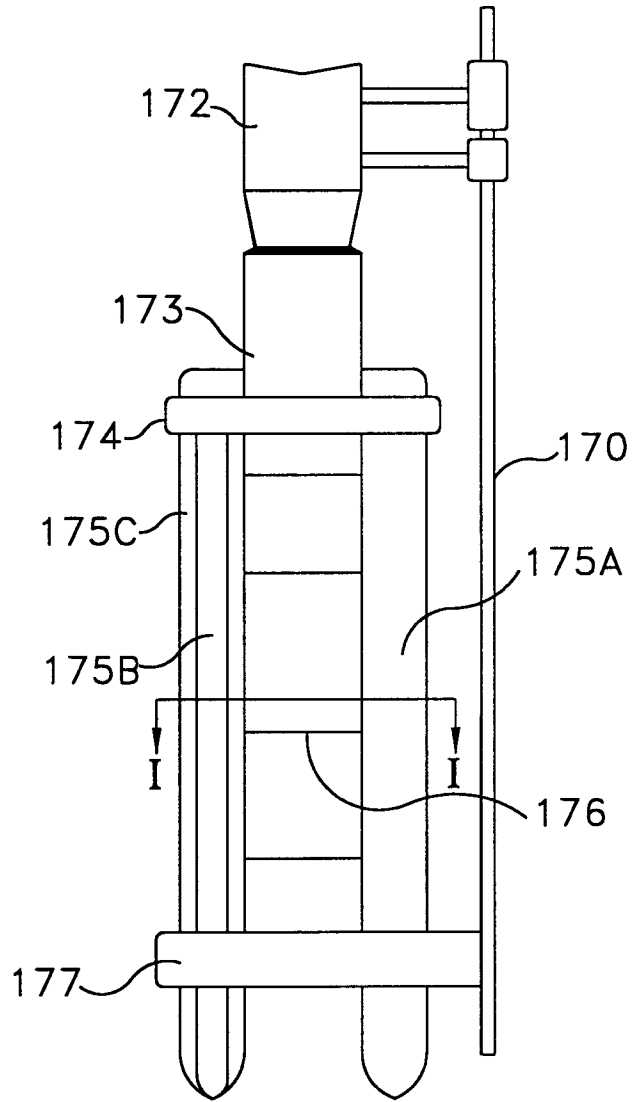

FIG.12 B

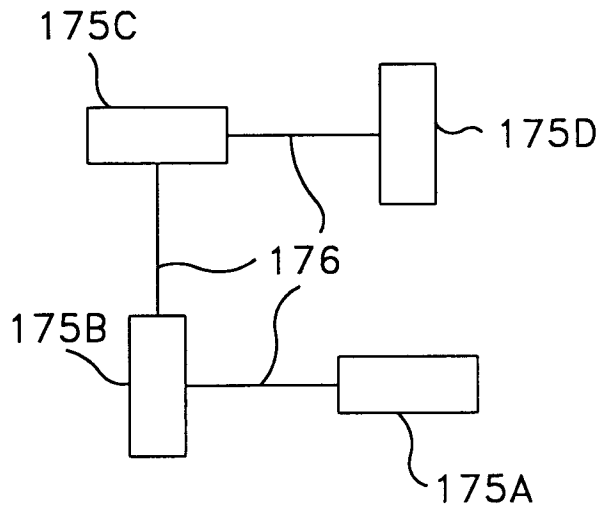

FIG.13A

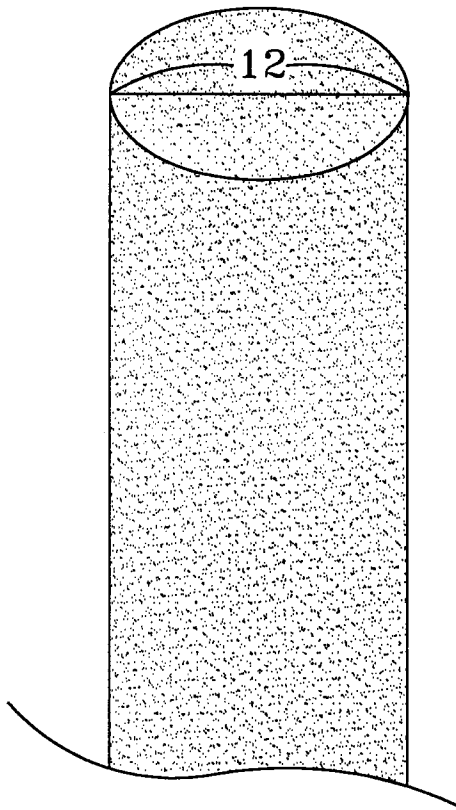
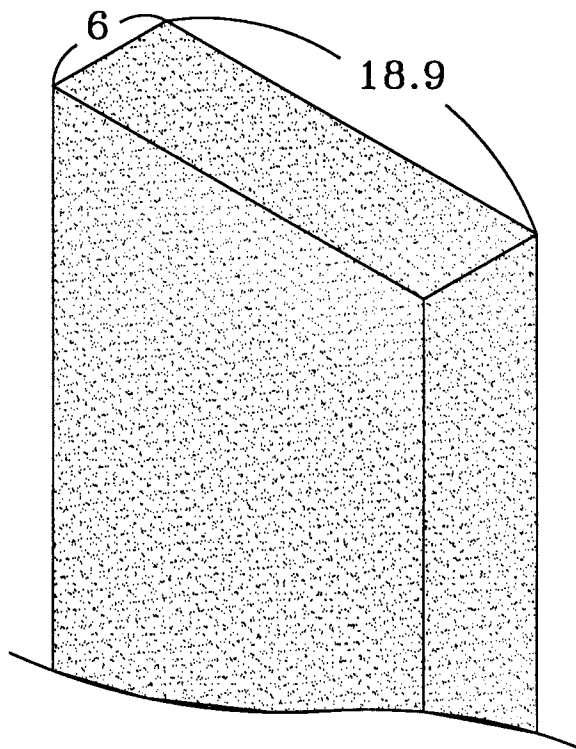

FIG.13B



INTERNATIONAL SEARCH REPORT

International application No.

PCT/KR96/00054

A. CLASSIFICATION OF SUBJECT MATTER Int. Cl ⁶ E02D3/10		
According to International Patent Classification (IPC) or to both national classification and IPC		
B. FIELDS SEARCHED		
Minimum documentation searched (classification system followed by classification symbols) Int. Cl ⁶ E02D3/10		
Documentation searched other than minimum documentation to the extent that such documents are included in the fields searched Jitsuyo Shinan Koho 1926 - 1996 Kokai Jitsuyo Shinan Koho 1971 - 1996		
Electronic data base consulted during the international search (name of data base and, where practicable, search terms used)		
C. DOCUMENTS CONSIDERED TO BE RELEVANT		
Category*	Citation of document, with indication, where appropriate, of the relevant passages	Relevant to claim No.
A	JP, 51-20304, U (Nihon Kaihatsu Consultant K.K.), February 14, 1976 (14. 02. 76), Fig. 3 (Family: none)	1 - 6
A	JP, 54-153105, U (Nippon Oil Co., Ltd.), October 24, 1979 (24. 10. 79) (Family: none)	2, 6
A	JP, 49-83813, U (Hisashi Sato), July 19, 1974 (19. 07. 74) (Family: none)	3
A	JP, 61-49017, A (Toa Corp.), March 10, 1986 (10. 03. 86),	5, 19
X	Figs. 3, 6 (Family: none)	18
X	Microfilm of the specification and drawings annexed to the written application of Japanese Utility Model Application No. 70499/1975 (Laid-open No. 149904/1976) (Asahi Chemical Industry Co., Ltd.), November 30, 1976 (30. 11. 76),	7-8, 10
<input checked="" type="checkbox"/> Further documents are listed in the continuation of Box C.		<input type="checkbox"/> See patent family annex.
* Special categories of cited documents:		"T" later document published after the international filing date or priority date and not in conflict with the application but cited to understand the principle or theory underlying the invention
"A" document defining the general state of the art which is not considered to be of particular relevance		"X" document of particular relevance; the claimed invention cannot be considered novel or cannot be considered to involve an inventive step when the document is taken alone
"E" earlier document but published on or after the international filing date		"Y" document of particular relevance; the claimed invention cannot be considered to involve an inventive step when the document is combined with one or more other such documents, such combinations being obvious to a person skilled in the art
"L" document which may throw doubt on priority claim(s) or which is cited to establish the publication date of another citation or other special reason (as specified)		"&" document member of the same patent family
"O" document referring to an oral disclosure, use, exhibition or other means		
"P" document published prior to the international filing date but later than the priority date claimed		
Date of the actual completion of the international search August 1, 1996 (01. 08. 96)	Date of mailing of the international search report August 13, 1996 (13. 08. 96)	
Name and mailing address of the ISA/ Japanese Patent Office Facsimile No.	Authorized officer Telephone No.	

Form PCT/ISA/210 (second sheet) (July 1992)

INTERNATIONAL SEARCH REPORT

International application No.

PCT/KR96/00054

C (Continuation). DOCUMENTS CONSIDERED TO BE RELEVANT		
Category*	Citation of document, with indication, where appropriate, of the relevant passages	Relevant to claim No.
	Page 4, lines 3 to 15; page 6, lines 2 to 5; Figs. 1, 2 (Family: none)	
A X	JP, 63-27549, U (Ohbayashigumi, Ltd.), February 23, 1988 (23. 02. 88), Figs. 1, 4 (Family: none)	11 - 14 7, 10
A	JP, 54-28406, A (Saeki Kensetsu Kogyo Co., Ltd.), March 3, 1979 (03. 03. 79) (Family: none)	13 - 14
A	JP, 61-26730, U (Fudo Construction Co., Ltd.), February 18, 1986 (18. 02. 86) (Family: none)	15
A	JP, 45-32743, Y1 (Tatsuo Morimoto), December 14, 1970 (14. 12. 70) (Family: none)	16
A	JP, 61-186612, A (Tatsuo Morimoto), August 20, 1986 (20. 08. 86) & US, 4745979, A	17
A	JP, 61-135938, U (Toyo Construction Co., Ltd.), August 23, 1986 (23. 08. 86), Figs. 1, 2, 4 (Family: none)	20
A	JP, 51-28309, A (San & C. Consultant K.K.), March 10, 1976 (10. 03. 76), Page 1, right column, line 16 to page 2, upper left column, line 12 (Family: none)	21 - 22

Form PCT/ISA/210 (continuation of second sheet) (July 1992)