



(12) EUROPEAN PATENT APPLICATION

(43) Date of publication:  
18.03.1998 Bulletin 1998/12

(51) Int Cl. 6: E04B 1/70

(21) Application number: 97202809.6

(22) Date of filing: 13.09.1997

(84) Designated Contracting States:  
AT BE CH DE DK ES FI FR GB GR IE IT LI LU MC  
NL PT SE  
Designated Extension States:  
AL LT LV RO SI

(72) Inventor: Schrijver, Hendrikus Bernardus  
Antonius  
2380 Ravels (BE)

(74) Representative: Debrabandere, René  
Bureau De Rycker nv  
Arenbergstraat 13  
2000 Antwerpen (BE)

(30) Priority: 13.09.1996 BE 9600774

(71) Applicant: Schrijver Systeem Vochtbestrijding  
N.V., naamloze vennootschap.  
2380 Ravels (BE)

(54) Improved device to abstract moisture from a wall or similar

(57) 1.- Improved device to abstract moisture from a wall or similar, consisting of air guide means (7) which can be applied in a hole (8) in a wall (2) and which define an air guide channel (9) between two openings (10-11), which extend in different directions outside the wall (2),

whereby the air that flows through the air guide channel (9), can carry off moisture originating from the wall (2), characterized in that the device (1) is provided with means (13) which form a cover between the air guide channel (9) and a cavity (5), possibly present in the wall (2) or similar.

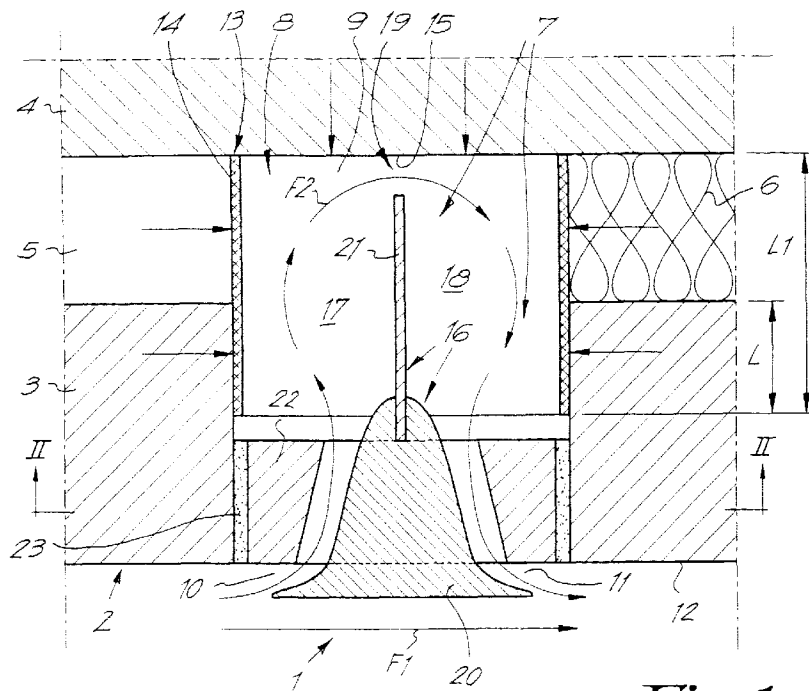

Fig. 1

## Description

The present invention relates to a device to abstract moisture from a wall or similar, more particularly from a wall made of masonry, concrete or other moisture-absorbent materials.

A device to abstract moisture from a wall is known from the Dutch patent no. 183.148. According to this patent, use is made of a device which is secured in a hole that is realised in a wall that is to be dried or to be kept dry.

This hole is, for example, obtained by the removal of a brick from the outer wall and possibly by further cutting out the wall that is to be dried, until the hole shows a depth of approximately 2/3 of the total thickness of the wall.

This known device consists, on the one hand, of a frame that is placed in the aforesaid hole and, on the other hand, of a separate body that extends outside the outer wall as well as in the hole, and is provided in this hole with a partition, whereby this body and this partition divide the hole into two chambers, leaving free a passage.

When the wind flows along the outer wall, a part thereof, due to the contact with the aforesaid protruding body, will be forced through the chambers and the air, present therein, that contains moisture from the wall, will be displaced, which will finally result in a drying effect.

A disadvantage of this known device occurs when it is applied in a cavity wall. In such case namely, the cavity must be bricked up at the spot of the wall of the hole, in which the device is applied, which is time-consuming and difficult to realise.

The invention concerns a device which can be applied in a single wall or as well as in a cavity wall, and which does not show the aforesaid disadvantage when applied in a cavity wall.

To this end the invention concerns an improved device to abstract moisture from a wall or similar, consisting of air guide means, which can be applied in a hole in a wall, and which define an air guide channel between two openings which extend, in different directions, outside the wall, whereby the air, that flows through the air guide channel, can carry off moisture, originating from the wall, characterized in that the device is provided with means, which form a cover between the air guide channel and a cavity, possibly present in the wall or similar.

In order to better show the characteristics of the invention, a preferred embodiment of a device according to the present invention is described hereafter, as an example, and without any restrictive character whatsoever, reference being made to the accompanying drawings, in which:

figure 1 represents a cross-sectional view of a cavity wall with a device according to invention;

figure 2 represents a cross-sectional view accord-

ing to line II-II in figure 1.

As represented in figure 1, the invention concerns a device 1 to abstract moisture from a wall 2, more particularly a cavity wall.

As is known, such cavity wall consists of an outer wall 3 and an inner wall 4, between which a space is present, namely a so-called cavity 5. This cavity 5 can, either as represented on the left-hand part of figure 1, be left free so that an air cavity is created, or can, as represented on the right-hand part of figure 1, be completely or partly filled with insulating material 6 or similar.

The device 1 according to the invention consists of air guide means 7 which can be applied in a hole 8 in the wall 2 and which define an air guide channel 9 between two openings 10-11 which extend in different directions outside the wall 2, more particularly outside the outer side of the wall 2. Hereto, the air guide means 7 are realised in such a way that the air that flows through the air guide channel 9, can directly or indirectly carry off moisture originating from the wall 2.

The particularity of the present invention lies in the fact that the device 1 is provided with means 13 which form a cover between the air guide channel 9 and the surrounding cavity 5.

As represented in figure 1 these means 13 preferably consist of a duct-shaped element 14 which forms at least a sealing wall between the concerned hole 8 and the surrounding cavity 5. More particularly, it is preferred that this duct-shaped element 14 shows such an axial length L1, that, during its application, on the one hand a sealing wall is formed between the hole 8 and the cavity 5 and, on the other hand, the element 14, extends, at least over a determined length L, in the outer wall 3, as a result of which it is kept in the hole 8.

The device 1, and more particularly the duct-shaped element 14, is preferably open at its head extremity which is situated at the furthestmost point of the outer side 12, in such a way that the inner wall 4 limits the air guide channel 9 with one side 15.

The aforesaid cover, and more particularly the duct-shaped element 14, preferably forms a loose part, in other words, a part which stands loose in relation to the aforesaid air guide means 7.

The means 13, and more particularly the duct-shaped element 14, respectively, is preferably formed by a porous, moisture-permeable material, which fully or considerably prevents the flow of the air.

Hereto it is particularly preferred that use is made of ceramics, such as pottery material. These means 13 can also consist of a cover that is made of the same material as the one that is used to manufacture bricks.

The device 1, and thus also the duct-shaped element 14, show, in a vertical cross-section, parallel to the wall 2, preferably and mainly a rectangular shape.

As represented in the figures 1 and 2, the air guide means 7 mainly consist of a vertically separating wall 16, preferably extending over the full or nearly full height

of the hole 8, the duct-shaped element 14, respectively, which divides the hole 8 in two adjacent chambers 17-18, whereby, at the back, a passage 19 is left between the two chambers.

In the represented example, the separating wall 16 is partly formed of a body 20 that is clock-shaped, in a horizontal cross-section, and that is elongated with a plate-shaped partition 21.

The separating wall 16 is secured in a rectangular frame 22.

The installation of the device 1 is as follows.

Firstly, a hole 8 is realised, by making an opening into the outer wall 3. Subsequently, the duct-shaped element 14 is applied therein. When it does not exactly fit the circumference, the gap, which then occurs, between this element 14 and the outer wall 3, can be filled up with for example mortar.

Subsequently, the frame 22 with the separating wall 16, is then secured in the hole 8, for example, also by means of mortar 23, cement or similar.

The operation of the device is based on the fact that, when an air flow F1 is created along the wall 2, for example due to the wind, also an air flow F2 is created through the air guide channel 9, as a result of which a drying effect is obtained. Indeed, the moisture from the wall 2, saturates the air in the hole 8, and this humid air is driven outside by the air flow F2.

It is hereby observed that, in such a manner, moisture from the outer wall 3, the inner wall 4 as well as from the cavity 5, can be carried away.

According to a variant, these means 13, and more particularly the duct-shaped element 14, can be realised undivided with the remainder of the device or can be connected herewith, for example, by means of ribs, which are not represented, between the frame 22 and the element 14.

These means can also be manufactured from plastic material or another material, that is provided with the required openings and/or perforations, in such a way that the moisture can be abstracted from the surrounding parts of the wall 2, and also in such a way that the air flow F2 is not disturbed by the presence of the cavity 5.

The present invention is in no way limited to the embodiment described above and represented in the drawings, but such improved device to abstract moisture from a wall can be realised in different shapes and dimensions, without leaving the scope of the invention.

## Claims

1. Improved device to abstract moisture from a wall or similar, consisting of air guide means (7) which can be applied in a hole (8) in a wall (2) and which define an air guide channel (9) between two openings (10-11), which extend in different directions outside the wall (2), whereby the air that flows through the

air guide channel (9), can carry off moisture originating from the wall (2), characterized in that the device (1) is provided with means (13) which form a cover between the air guide channel (9) and a cavity (5), possibly present in the wall (2) or similar.

2. Improved device according to claim 1, characterized in that the means (13) which form a cover, consist of a porous, moisture-permeable material.

3. Improved device according to claim 2, characterized in that the aforesaid means (13) mainly consist of ceramics.

4. Improved device according to anyone of the preceding claims, characterized in that the aforesaid means (13) consist of a duct-shaped element (14), which forms at least a sealing wall between the aforesaid hole (8) and the surrounding cavity (5).

5. Improved device according to claim 4, characterized in that the duct-shaped element (14) shows at least an axial length (L1), in such a way that, during its application in a cavity wall, for which it is designed, it forms, on the hand, a sealing wall between the aforesaid hole (8) and the surrounding cavity (5) and, on the other hand, extends, at least over a certain length (L), in the outer wall (3).

6. Improved device according to anyone of the preceding claims, characterized in that it is open at its head extremity, in such a way that, during its application in a cavity wall, the inner wall (4) limits the air guide channel (9).

7. Improved device according to anyone of the preceding claims, characterized in that the aforesaid means (13) are formed by an element, more particularly a duct-shaped element (14), that forms a loose part in relation to the remaining air guide means (7).

8. Improved device according to anyone of the preceding claims, characterized in that it shows in a vertical cross-section, parallel to the wall (2), just like the duct-shaped element (14), a mainly rectangular shape.

9. Improved device according to anyone of the preceding claims, characterized in that the air guide means (7) mainly consist of a vertically separating wall (16), preferably extending over the full or nearly full height, which divides the hole (8) in two adjacent chambers (17-18), whereby, at the back, a passage (19) is left between the two chambers (17-18).

10. Improved device according to claim 9, characterized in that the separating wall (16) is, at least par-

tially, formed of a body (20) that, in a horizontal direction, is clock-shaped, whereby this body (20) is elongated with a plate-shaped partition (21), or not.

11. Improved device according to claim 9 or 10, characterized in that it contains a frame (22), in which the partition (21) is secured, that is to be fixed in the hole (8).

5

10

15

20

25

30

35

40

45

50

55

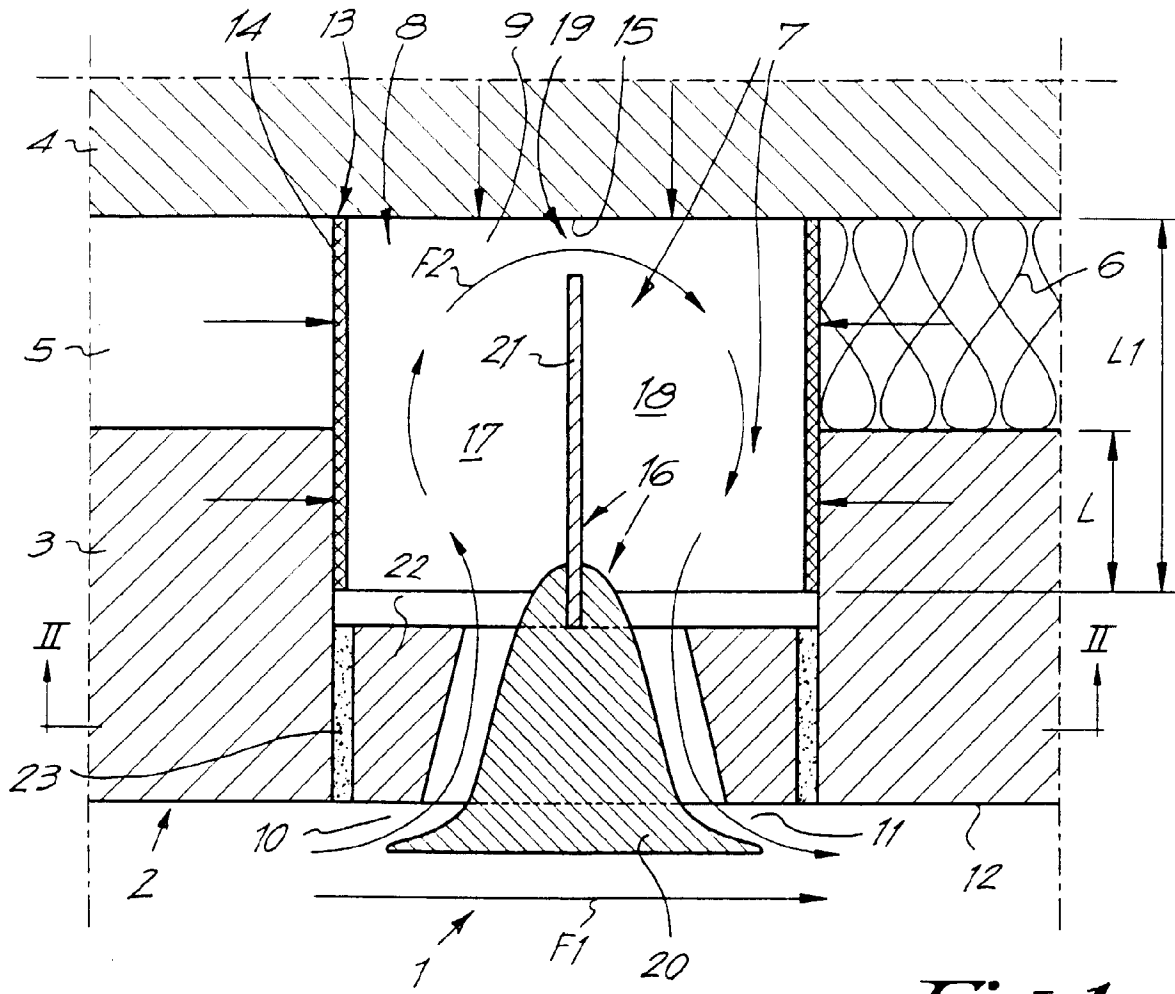

*Fig. 1*

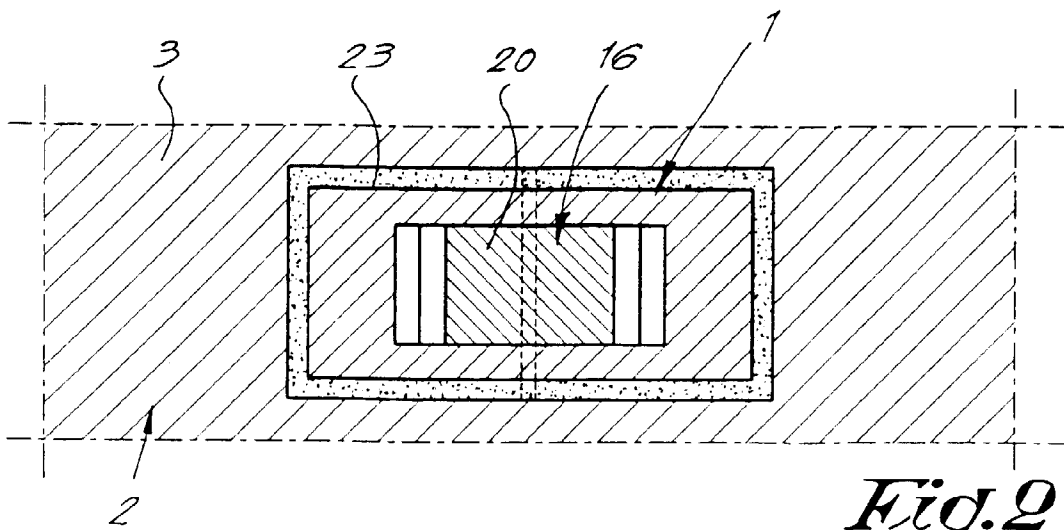

*Fig. 2*



European Patent  
Office

EUROPEAN SEARCH REPORT

Application Number  
EP 97 20 2809

DOCUMENTS CONSIDERED TO BE RELEVANT			
Category	Citation of document with indication, where appropriate, of relevant passages	Relevant to claim	CLASSIFICATION OF THE APPLICATION (Int.Cl.6)
D,A	NL 8 104 784 A (SCHRIJVER SYSTEEM VOCHTBESTRIJ) 16 May 1983 * page 3, line 26 - page 5, line 20; figures *	1.6.9-11	E04B1/70
A	FR 2 674 553 A (KINGHRON LTD) 2 October 1992 * abstract; figure 1 *	1.2.4	
A	NL 8 500 177 A (HENDRIK WILLEM RUDOLF KOSTER) 18 August 1986 * page 4, line 29 - page 5, line 3; figure 4 *	1.6.9-11	
A	CH 394 564 A (J. SCHÖNLECHNER) 30 November 1965 * page 2, line 83 - page 3, line 4; figures *	1.9.10	
A	DE 11 10 846 B (K. PALMER) 13 July 1961 * column 2, line 50 - column 3, line 48; figures 1-3,6,7 *	1.9.10	
			TECHNICAL FIELDS SEARCHED (Int.Cl.6)
			E04B
The present search report has been drawn up for all claims			
Place of search THE HAGUE		Date of completion of the search 3 December 1997	Examiner Kriekoukis, S
CATEGORY OF CITED DOCUMENTS		T : theory or principle underlying the invention E : earlier patent document, but published on, or after the filing date D : document cited in the application L : document cited for other reasons & : member of the same patent family, corresponding document	
X : particularly relevant if taken alone Y : particularly relevant if combined with another document of the same category A : technological background O : non-written disclosure P : intermediate document			

EPO FORM 1503 03/82 (P14/C01)