



(12) **EUROPEAN PATENT APPLICATION**

(88) Date of publication A3:
24.03.1999 Bulletin 1999/12

(51) Int. Cl.⁶: **G11B 7/135, G11B 7/095**

(43) Date of publication A2:
18.03.1998 Bulletin 1998/12

(21) Application number: **97308211.8**

(22) Date of filing: **10.11.1995**

(84) Designated Contracting States:
DE FR GB NL

(72) Inventors:
• **Ikegame, Tetsuo**
Hachioji City, Tokyo (JP)
• **Nakano, Osamu**
Hachioji City, Tokyo (JP)

(30) Priority: **10.11.1994 JP 276491/94**

(62) Document number(s) of the earlier application(s) in accordance with Art. 76 EPC:
95308059.5 / 0 712 122

(74) Representative:
Fenlon, Christine Lesley et al
Haseltine Lake & Co.,
Imperial House,
15-19 Kingsway
London WC2B 6UD (GB)

(71) Applicant:
Olympus Optical Co., Ltd.
Tokyo (JP)

(54) **Information recording and/or reproducing apparatus**

(57) An information recording/reproducing apparatus for recording and/or reproducing information on and/or from an optical recording medium comprises a light source (50), at least two objective lenses (4,5) corresponding to at least two kinds of optical recording media (1,2) having different thicknesses of protective layer, respectively, a holder (6) for supporting these objective lenses (4,5), selection means for selecting one of these objective lenses in accordance with that one of the optical recording media (1,2) to be read, the light of the light source (50) being directed onto that optical recording medium (1,2) through the objective lens (4,5) selected by the selection means, thereby performing recording and/or reproducing of the information.

FIG. 2

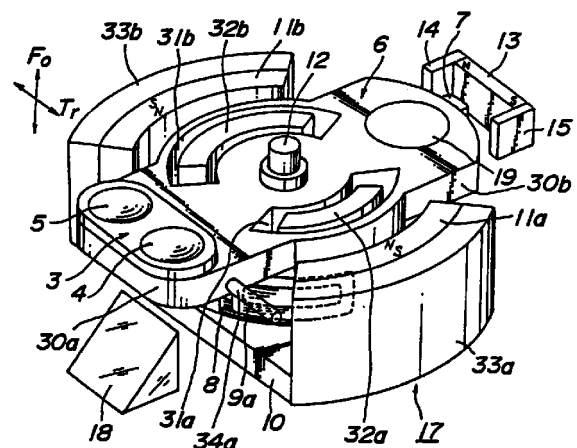



European Patent Office

EUROPEAN SEARCH REPORT

Application Number
EP 97 30 8211

DOCUMENTS CONSIDERED TO BE RELEVANT			
Category	Citation of document with indication, where appropriate, of relevant passages	Relevant to claim	CLASSIFICATION OF THE APPLICATION (Int.Cl.6)
X	PATENT ABSTRACTS OF JAPAN vol. 018, no. 624 (P-1833), 28 November 1994 -& JP 06 236570 A (RICOH CO LTD), 23 August 1994 * abstract; figures 1-11 * ---	1	G11B7/135 G11B7/09 G11B7/095
A	EP 0 470 807 A (MATSUSHITA ELECTRIC IND CO LTD) 12 February 1992 * column 12, line 28 - column 14, line 30 * * column 9, line 37 - line 50; figure 3 * * column 16, line 39 - column 17, line 2 * ---	1	
A	PATENT ABSTRACTS OF JAPAN vol. 001, no. 104 (E-044), 14 September 1977 -& JP 52 037404 A (MATSUSHITA ELECTRIC IND CO LTD), 23 March 1977 * abstract; figure 3 * ---	1	
P,X	PATENT ABSTRACTS OF JAPAN vol. 095, no. 005, 30 June 1995 -& JP 07 037259 A (RICOH CO LTD), 7 February 1995 * abstract; figure 5 * -----	1	TECHNICAL FIELDS SEARCHED (Int.Cl.6) G11B
The present search report has been drawn up for all claims			
Place of search THE HAGUE		Date of completion of the search 4 February 1999	Examiner Holubov, C
CATEGORY OF CITED DOCUMENTS X : particularly relevant if taken alone Y : particularly relevant if combined with another document of the same category A : technological background O : non-written disclosure P : intermediate document		T : theory or principle underlying the invention E : earlier patent document, but published on, or after the filing date D : document cited in the application L : document cited for other reasons ----- & : member of the same patent family, corresponding document	

EPO FORM 1503 03/82 (P04C01)

**ANNEX TO THE EUROPEAN SEARCH REPORT
ON EUROPEAN PATENT APPLICATION NO.**

EP 97 30 8211

This annex lists the patent family members relating to the patent documents cited in the above-mentioned European search report. The members are as contained in the European Patent Office EDP file on
The European Patent Office is in no way liable for these particulars which are merely given for the purpose of information.

04-02-1999

Patent document cited in search report	Publication date	Patent family member(s)	Publication date
EP 0470807 A	12-02-1992	JP 4281232 A	06-10-1992
		JP 2626205 B	02-07-1997
		JP 4095224 A	27-03-1992
		JP 4157635 A	29-05-1992
		DE 69125543 D	15-05-1997
		DE 69125543 T	13-11-1997
		EP 0727775 A	21-08-1996
		SG 43229 A	17-10-1997
		US 5235581 A	10-08-1993
