



(12) EUROPEAN PATENT APPLICATION

(88) Date of publication A3:
18.11.1998 Bulletin 1998/47

(51) Int. Cl.⁶: G11B 7/09

(43) Date of publication A2:
25.03.1998 Bulletin 1998/13

(21) Application number: 97115760.7

(22) Date of filing: 10.09.1997

(84) Designated Contracting States:
AT BE CH DE DK ES FI FR GB GR IE IT LI LU MC
NL PT SE

(72) Inventors:
• Takagi, Hirohito
Chiba-City, Chiba 267 (JP)
• Schemmann, Heinrich
78052 Villingen-Schwenningen (DE)

(30) Priority: 23.09.1996 DE 19638879

(71) Applicant:
DEUTSCHE THOMSON-BRANDT GMBH
78048 Villingen-Schwenningen (DE)

(74) Representative:
Wördemann, Hermes, Dipl.-Ing.
Deutsche Thomson-Brandt GmbH,
Licensing & Intellectual Property,
Göttinger Chaussee 76
30453 Hannover (DE)

(54) Method for processing the output signals of an optoelectronic scanner in a replay or recording appliance, and a corresponding appliance

(57) A method is specified for processing the output signals A to F of an optoelectronic scanner (3) in a replay or recording appliance for replaying from or recording onto an optical recording medium having the following method steps: as well as an appliance with a corresponding input circuit of a digital servo controller: first of all, the output signals A to F are supplied directly to an A/D converter (2) without the interposition of a low-pass filter, and are digitized with n-times oversampling. The digitized output signals are then supplied to a k-th order comb filter (4) by means of which undersampling

of the signals to the normal sampling frequency (44.1 kHz) is carried out. After this, the undersampled output signals A' to F' of the comb filter (4) are supplied to a trimming and correction circuit (6) in which trimming and correction, of OFFSET and BALANCE are respectively carried out. Finally, the trimmed/corrected output signals A'' to F'' are supplied to the trimming and correction circuit of a digital servo circuit (1), by means of which a focusing error signal (FE) and a track deviation error signal (TE) are produced.

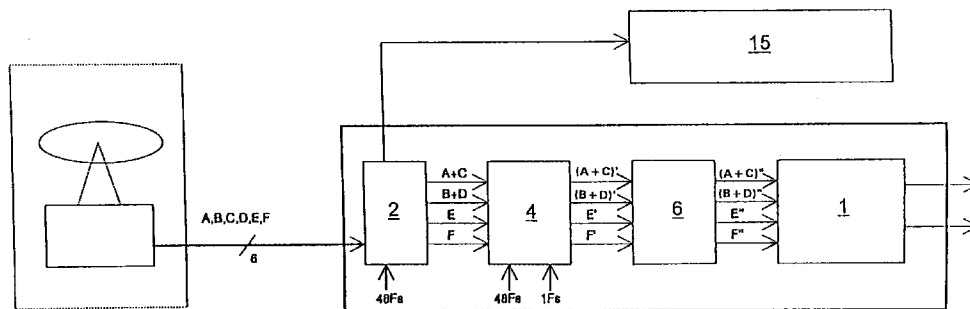

Fig. 2



European Patent
Office

EUROPEAN SEARCH REPORT

Application Number
EP 97 11 5760

DOCUMENTS CONSIDERED TO BE RELEVANT			
Category	Citation of document with indication, where appropriate, of relevant passages	Relevant to claim	CLASSIFICATION OF THE APPLICATION (Int.Cl.6)
A	PATENT ABSTRACTS OF JAPAN vol. 14, no. 59 (P-1000), 2 February 1990 & JP 01 283607 A (MATSUSHITA ELECTRIC IND CO), 15 November 1989, * abstract *	1,6	G11B7/09
A	--- PATENT ABSTRACTS OF JAPAN vol. 14, no. 333 (P-1078), 18 July 1990 & JP 02 113478 A (SONY CORP), 25 April 1990, * abstract *	1,6	
A	--- S. MATSUJKAWA ET AL.: "an advanced sector servo using a learning, estimating and oversampling method for a 3.5'' 28 Mbyte FDD" IEEE TRANSACTIONS ON MAGNETICS, vol. 27, no. 6, pt . 1, November 1991, NY, USA, pages 4484-4489, XP000257366 * page 4485, paragraph 3 *	1,6	
			TECHNICAL FIELDS SEARCHED (Int.Cl.6)
			G11B
The present search report has been drawn up for all claims			
Place of search		Date of completion of the search	Examiner
MUNICH		29 September 1998	Chaumeron, B
CATEGORY OF CITED DOCUMENTS			
X : particularly relevant if taken alone Y : particularly relevant if combined with another document of the same category A : technological background O : non-written disclosure P : intermediate document		T : theory or principle underlying the invention E : earlier patent document, but published on, or after the filing date D : document cited in the application L : document cited for other reasons & : member of the same patent family, corresponding document	

EPO FORM 1503 03/82 (P04C01)