

(19)



Europäisches Patentamt

European Patent Office

Office européen des brevets



(11)

EP 0 839 903 A1

(12)

EUROPEAN PATENT APPLICATION

(43) Date of publication:
06.05.1998 Bulletin 1998/19

(51) Int. Cl.⁶: **C11D 3/39**, C11D 3/37

(21) Application number: **96870137.5**

(22) Date of filing: **31.10.1996**

(84) Designated Contracting States:
**AT BE CH DE DK ES FI FR GB GR IE IT LI LU MC
NL PT SE**
Designated Extension States:
AL LT LV RO SI

(71) Applicant:
THE PROCTER & GAMBLE COMPANY
Cincinnati, Ohio 45202 (US)

(72) Inventors:
• **Del Duca, Valerio**
80064 Massalubrense (Napoli) (IT)

• **O'Sullivan, Dennis Gerard**
00144 Rome (IT)
• **Ricci, Carlo**
00151 Rome (IT)

(74) Representative:
Engisch, Gautier et al
Procter & Gamble
European Technical Center N.V.
Temseleen 100
1853 Strombeek-Bever (BE)

(54) **Liquid aqueous bleaching compositions and pretreatment process**

(57) The present invention relates to an acidic aqueous composition suitable for pretreating soiled fabrics comprising a peroxygen bleach and a soil suspending agent selected from the group consisting of an ethoxylated cationic diamine, an ethoxylated cationic polyamine, an ethoxylated cationic amine polymer and mixtures thereof. This invention is also a process for pretreating soiled fabrics with such a composition.

EP 0 839 903 A1

Description

Technical field

5 The present invention relates to liquid acidic aqueous bleaching compositions particularly suitable to be used as a pretreater and to a process of pretreating fabrics.

Background

10 A great variety of liquid aqueous cleaning compositions have been described in the art, that are particularly suitable for pretreating fabrics.

A problem associated with common liquid aqueous cleaning compositions, especially those containing a peroxy-
gen bleach, when used to pretreat different kinds of fabrics, including cotton and synthetic fabrics such as polyesters,
polyamides and the like, is that they do not deliver an effective performance satisfactorily meeting consumer's needs,
15 on all types of stains including greasy stains, enzymatic stains, mud/clay stains and the like. Also it has been found that
a problem with such liquid peroxygen bleach-containing compositions is that despite the tendency of the peroxygen
bleach to migrate to the fabric surface, it does not necessarily interact fully with the bleachable stain or soil components.
It has been found that the peroxygen bleaches can be prevented from migration onto bleachable stains/soils (such as
peat stains) by deposition on the fabric of other active ingredients that may be present in such a liquid peroxygen
20 bleach-containing composition such as clay-soil particulates on the fabric. Thereby, their bleaching performance can be
diminished. This results in a lessening of the bleachable/ dingy soil cleaning performance of the peroxygen bleach.

It is thus an object of the present invention to provide improved stain removal performance on a wide range of stains
as well as excellent bleaching performance, especially under laundry pretreatment conditions, i.e., when applying a li-
quid aqueous composition neat onto at least a portion of a soiled fabric before washing said fabric.

25 Also suitable ingredients to be used in a liquid aqueous peroxygen bleach-containing composition must be selected
such that they are suitable for imparting the desirable stain removal performance to such a composition. However, the
use of such ingredients must not lead to an unacceptable degree of chemical stability.

Given the foregoing, there is clearly a continuing need to identify and provide liquid aqueous peroxygen bleach-
containing compositions, suitable for pretreating fabrics, that have a commercially acceptable chemical stability along
30 with an excellent overall stain removal performance and bleaching performance.

It has now been found that improved stain removal performance is obtained, by using an aqueous composition
being formulated in the acidic pH range at a pH below 6, and comprising a peroxygen bleach and a soil suspending
agent selected from the group consisting of an ethoxylated cationic diamine, an ethoxylated cationic polyamine, an
ethoxylated cationic amine polymer and mixture thereof, as described hereinafter, to pretreat soiled fabrics, while main-
35 taining adequate chemical stability. Indeed, it has now been found that the soil suspending agents, as defined herein,
are easily processed in the acidic aqueous compositions according to the present invention comprising a peroxygen
bleach with a reduced impact on the chemical stability properties of said compositions. In other words, the specific soil
suspending agents, as defined herein, are fully compatible with peroxygen beaches in acidic medium.

Indeed, the acidic aqueous compositions of the present invention comprising a peroxygen bleach and a soil sus-
40 pending agent, as defined herein, deliver improved stain removal performance on various types of stains including
greasy stains, enzymatic stains, clay/mud stains, and the like, under laundry pretreatment conditions, as compared to
the stain removal performance delivered by the same compositions without said soil suspending agent. Also, it has sur-
prisingly been found that the acidic aqueous compositions comprising both the peroxygen bleach and said soil sus-
pending agent, when used to pretreat fabrics, provide improved bleaching efficacy, as compared to the same
45 compositions without said soil suspending agent. Thus, it has been found that the addition of a single compound, i.e.,
such a soil suspending agent, in an acidic aqueous peroxygen bleach-containing composition, delivers both improved
stain removal performance and improved bleaching performance. Furthermore, it has been found that this improved
stain removal performance on various stains and improved bleaching performance is maintained even for acidic aque-
ous peroxygen bleach-containing compositions having undergone long storage periods.

50 An advantage of the present invention is that chemically and physically stable acidic aqueous compositions are pro-
vided that are suitable to be used in the most efficient manner by the consumer over prolonged period of time.

Furthermore, it has been found that in a preferred embodiment of the present invention, the acidic aqueous com-
positions herein may be formulated either as an emulsion or microemulsion, without the need for modifying the rheology
of the compositions. Indeed, it has been found that said soil suspending agent reduces the viscosity of an acidic aque-
ous composition herein comprising a peroxygen bleach, whatever the viscosity was before the addition of said soil sus-
55 pending agent.

Background art

EP-A-271 312 discloses laundry compositions comprising a peroxyacid bleach and a soil release agent like particular alkyl and hydroxyalkyl ethers of cellulose, polymers comprising ethylene terephthalate and polyethylene oxide terephthalate. No ethoxylated cationic diamines, ethoxylated cationic polyamines, ethoxylated cationic polymers are disclosed.

US 4 659 802 discloses detergent compositions comprising ethoxylated cationic diamines, ethoxylated cationic polyamines and/or ethoxylated cationic polymers as a clay soil removal/antiredeposition agent. No peroxygen bleaches are disclosed.

EP-A-111 965 discloses detergent compositions (pH= 6 to 8.5) comprising ethoxylated cationic mono- or diamines, ethoxylated cationic polyamines and/or ethoxylated cationic polymers as a clay soil removal/antiredeposition agent. No peroxygen bleaches are disclosed.

Summary of the invention

The present invention encompasses a liquid aqueous composition suitable for pretreating fabrics, having a pH below 6 and comprising a peroxygen bleach, and a soil suspending agent selected from the group consisting of:

1) ethoxylated cationic diamines having the formula:

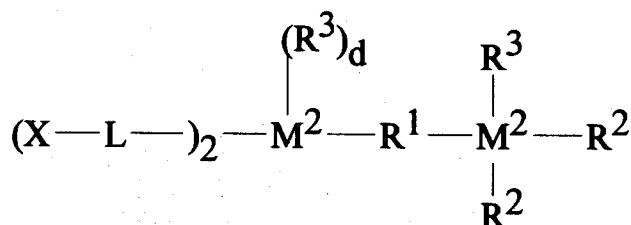
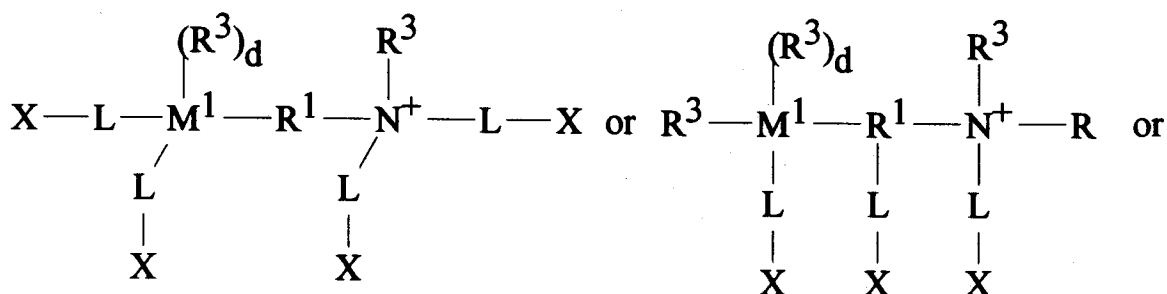

wherein M^1 is an N^+ or N group; each M^2 is an N^+ or N group, and at least one M^2 is an N^+ group;

2) ethoxylated cationic polyamines having the formula:

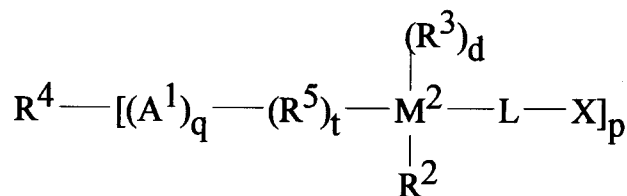

3) ethoxylated cationic polymers which comprises a polymer backbone, at least 2M groups and at least one L-X group, wherein M is a cationic group attached to or integral with the backbone; X is a nonionic group selected from the group consisting of H, C_1 - C_4 alkyl or hydroxyalkyl ester or ether groups, and mixtures thereof; and L is a hydrophilic chain connecting groups M and X or connecting X to the polymer backbone,

4) mixtures thereof;

wherein A^1 is

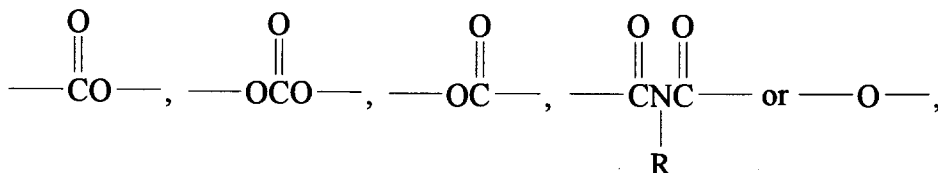
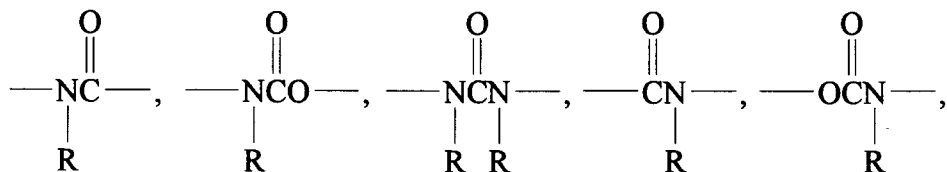

R is H or C₁-C₄ alkyl or hydroxyalkyl, R¹ is C₂-C₁₂ alkylene, hydroxyalkylene, alkenylene, arylylene or alkarylylene, or a C₂-C₃ oxyalkylene moiety having from 2 to about 20 oxyalkylene units provided that no O-N bonds are formed; each R² is C₁-C₄ alkyl or hydroxyalkyl, the moiety -L-X, or two R² together form the moiety -(CH₂)_r-A²-(CH₂)_s-, wherein A² is -O- or -CH₂-, r is 1 or 2, s is 1 or 2 and r + s is 3 or 4; each R³ is C₁-C₃ alkyl or hydroxyalkyl, benzyl, the moiety L-X, or two R³ or one R² and one R³ together form the moiety -(CH₂)_r-A²-(CH₂)_s-, R⁴ is a substituted C₃-C₁₂ alkyl, hydroxyalkyl, alkenyl, aryl or alkaryl group having p substitution sites; R⁵ is C₁-C₁₂ alkenyl, hydroxyalkylene, alkenylene, arylylene or alkarylylene, or a C₂-C₃ oxyalkylene moiety having from 2 to about 20 oxyalkylene units provided that no O-O or O-N bonds are formed; X is a nonionic group selected from the group consisting of H, C₁-C₄ alkyl or hydroxyalkyl ester or ether groups, and mixtures thereof; L is a hydrophilic chain which contains the polyoxyalkylene moiety -[(R⁶O)_m(CH₂CH₂O)_n]-; wherein R⁶ is C₃-C₄ alkylene or hydroxyalkylene and m and n are numbers such that the moiety -(CH₂CH₂O)_n- comprises at least about 50% by weight of said polyoxyalkylene moiety; d is 1 when M² is N⁺ and is 0 when M² is N; n is at least 6 for said cationic diamines and is at least 3 for said cationic polyamines and cationic polymers; p is from 3 to 8; q is 1 or 0; t is 1 or 0, provided that t is 1 when q is 1

The present invention also encompasses a process of bleaching a soiled fabric with a liquid acidic aqueous composition as defined herein before, said process comprising the steps of applying said composition in its neat form onto at least a portion of said fabric, before said fabric is washed.

Detailed description of the invention

The compositions

The present invention encompasses a liquid acidic aqueous composition suitable for pretreating fabrics, comprising a peroxygen bleach, and a soil suspending agent selected from the group consisting of an ethoxylated cationic diamine, an ethoxylated cationic polyamine, an ethoxylated cationic amine polymer and mixture thereof, as defined hereinbefore.

The addition of such a soil suspending agent in a liquid acidic aqueous composition comprising a peroxygen bleach, provides improved stain removal performance especially under laundry pretreatment conditions, on various stains including greasy stains, enzymatic stains, clay/mud stains as well as improved bleaching performance while maintaining adequate chemical stability.

By "stain removal performance" it is meant herein stain removal performance on a variety of stains/soils such as greasy/oily stains, and/or enzymatic stains and/or mud/clay stains (particulate stains). By "greasy/oily stains" it is meant herein any soil and stain of greasy nature that can be found on a fabric like dirty motor oil, mineral oil, make-up, lipstick, vegetable oil, spaghetti sauce, mayonnaise and the like. Examples of enzymatic stains include grass, chocolate and blood.

Three mechanisms are believed to be responsible for the unexpected benefits, i.e., improved stain removal and bleaching performance. Firstly, the peroxygen bleach is surface active, especially on organic material containing surfaces, and will thus migrate to the fabric surface. It will then be capable of removing organic bleachable material from the surface. Secondly, the soil suspending agent can interact with the negatively charged soils on the fabric surface, thereby neutralising the fabric surface. This will facilitate the migration of the peroxygen bleaches to the fabric surface.

Thirdly, the soil suspending agent is capable of removing and suspending soils like greasy soil, particulate soil (mud/clay) and/or enzymatic soil deposited on the fabric surface, thereby facilitating the partition of the peroxygen bleaches into bleachable stains/soils on the fabric.

The soil suspending agents herein are fully compatible with peroxygen bleaches. Without wishing to be bound by theory, the bleach-compatibility of the soil suspending agents herein can be explained as follows. The quaternization of the nitrogen groups of these molecules is believed to have a dual purpose. It provides a cationic charge on the molecule, improving adsorption onto stains/particles like clay on the fabric surface, and it removes the oxidisable lone pair on the nitrogen groups from attack by bleaching species, thus making the molecule stable in an aqueous peroxygen bleach containing composition. Also, the soil suspending agents herein are fully compatible with acidic medium.

The aqueous bleaching compositions of the present invention are chemically stable. By "chemically stable" it is meant herein that said compositions of the present invention comprising a peroxygen bleach do not undergo more than 20% available oxygen loss at 50°C in 2 weeks. The concentration of available oxygen can be measured by chemical titration methods known in the art, such as the iodimetric method, the permanganometric method and the cerimetric method. Said methods and the criteria for the choice of the appropriate method are described for example in "Hydrogen Peroxide", W. C. Schumb, C. N. Satterfield and R. L. Wentworth, Reinhold Publishing Corporation, New York, 1955 and "Organic Peroxides", Daniel Swern, Editor Wiley Int. Science, 1970. Alternatively, the stability of said compositions may also be evaluated by a bulging test method.

The bleaching compositions of the present invention are physically stable. By "physically stable" it is meant herein that the compositions of the present invention do not split in two or more phases when exposed in stressed conditions, e.g., at a temperature of 40 °C during 2 weeks.

The compositions according to the present invention are aqueous, thus they comprise from 50% to 98% by weight of the total composition of water, preferably from 50% to 95% and more preferably from 55% to 90%.

As an essential element the compositions according to the present invention comprise a peroxygen bleach or mixtures thereof.

The peroxygen bleach to be used herein is any peroxygen bleach, known to those skilled in the art. Such peroxygen bleach includes hydrogen peroxide, or a water-soluble source thereof, or mixtures thereof. Indeed, the presence of the peroxygen bleach contributes to the excellent cleaning and bleaching benefits of the compositions used according to the present invention. As used herein a hydrogen peroxide source refers to any compound which produces perhydroxyl ions when said compound is in contact with water.

Suitable water-soluble sources of hydrogen peroxide for use herein include percarbonates, persilicate, persulphate such as monopersulfate, perborates, peroxyacids such as diperoxydodecandioic acid (DPDA), magnesium perphthalic acid, perlauric acid, perbenzoic and alkylperbenzoic acids, hydroperoxides, diacyl peroxides and mixtures thereof. Preferred peroxygen bleaches used herein are hydrogen peroxide, hydroperoxide and/or aliphatic diacyl peroxide.

Suitable hydroperoxides for use herein are tert-butyl hydroperoxide, cumyl hydroperoxide, 2,4,4-trimethylpentyl-2-hydroperoxide, di-isopropylbenzenemonehydroperoxide, tert-amyl hydroperoxide and 2,5-dimethyl-hexane-2,5-dihydroperoxide. Such hydroperoxides have the advantage to be particularly safe to fabrics and color while delivering excellent bleaching performance.

Suitable aliphatic diacyl peroxides for use herein are dilauroyl peroxide, didecanoyl peroxide, dimyristoyl peroxide or mixtures thereof. Such aliphatic diacyl peroxides have the advantage to be particularly safe to fabrics and color while delivering excellent bleaching performance.

The compositions according to the present invention comprise from 0.01% to 15% by weight of the total composition of such a peroxygen bleach or mixtures thereof, preferably from 0.1% to 12%, more preferably from 0.5% to 10% and most preferably from 2% to 8%.

As an essential element the compositions according to the present invention comprise a soil suspending agent selected from the group consisting of ethoxylated cationic diamines, ethoxylated cationic polyamines, ethoxylated cationic amine polymers, as previously defined and mixtures thereof.

In the preceding formulas for the cationic amines, R¹ can be branched (e.g.

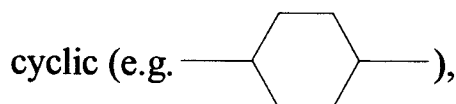
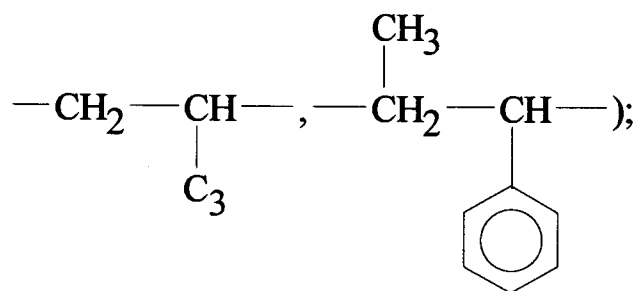

or must preferably linear

20 (e.g. $\text{---CH}_2\text{CH}_2\text{---}$, $\text{---CH}_2\text{CH}_2\text{---CH}_2\text{---}$) alkylene, hydroxyalkylene, alkenylene, alkarylene or oxyalkylene. R^1 is preferably C_2 - C_6 alkylene for the ethoxylated cationic diamines. Each R^2 is preferably methyl or the moiety ---L-X ; each R^3 is preferably C_1 - C_4 alkyl or hydroxyalkyl, and most preferably methyl.

The positive charge of the N^+ groups is offset by the appropriate number of counter anions. Suitable counter anions include $C1^-$, Br^- , SO_3^{2-} , PO_4^{2-} , $MeOSO_3^-$ and the like. Particularly preferred counter anions are $C1^-$ and Br^- .

25 X can be a nonionic group selected from hydrogen (H), C_1 - C_4 alkyl or hydroxyalkyl ester or ether groups, or mixtures thereof. Preferred esters or ethers are the acetate ester and methyl ether, respectively. The particularly preferred nonionic groups are H and the methyl ether.

In the preceding formulas, hydrophilic chain L usually consists entirely of the polyoxyalkylene moiety $\text{---}[(R^6O)_m(CH_2CH_2O)_n]\text{---}$. The moieties $\text{---}(R^6O)_m\text{---}$ and $\text{---}(CH_2CH_2O)_n\text{---}$ of the polyoxyalkylene moiety can be mixed together or preferably form blocks of $\text{---}(R^6O)_m\text{---}$ and $\text{---}(CH_2CH_2O)_n\text{---}$ moieties. R^6 is preferably C_3H_6 (propylene); m is preferably from 0 to about 5 and is most preferably 0, i.e. the polyoxyalkylene moiety consists entirely of the moiety $\text{---}(CH_2CH_2O)_n\text{---}$. The moiety $\text{---}(CH_2CH_2O)_n\text{---}$ preferably comprises at least about 85% by weight of the polyoxyalkylene moiety and most preferably 100% by weight (m is 0).

In the preceding formulas, M^1 and each M^2 are preferably an N^+ group for the cationic diamines and polyamines.

35 Preferred ethoxylated cationic diamines have the formula:

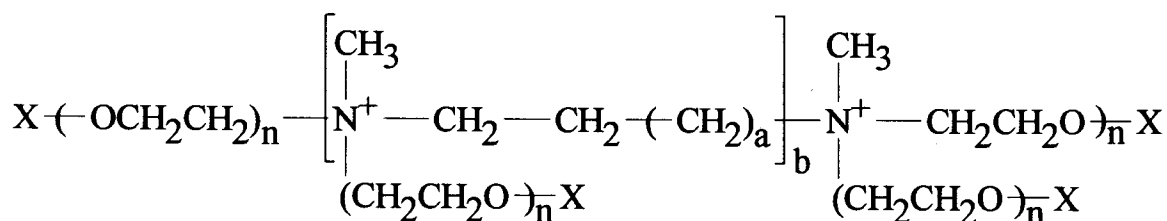

wherein X and n are defined as before, a is from 0 to 4 (e.g. ethylene, propylene, hexamethylene) b is 1. For preferred cationic diamines, n is at least about 12 with a typical range of from about 12 to about 42.

50 In the preceding formula for the ethoxylated cationic polyamines, R^4 (linear, branched, or cyclic) is preferably a substituted C_3 - C_6 alkyl, hydroxyalkyl or aryl group; A^1 is preferably

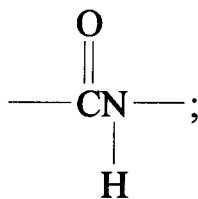

5

10 n is preferably at least about 12, with a typical range of from about 12 to about 42; p is preferably from 3 to 6. When R⁴ is a substituted aryl or alkaryl group, q is preferably 1 and R⁵ is preferably C₂-C₃ alkylene. When R⁴ is a substituted alkyl, hydroxyalkyl, or alkenyl group, and when q is 0, R⁵ is preferably a C₂-C₃ oxyalkylene moiety; when q is 1, R⁵ is preferably C₂-C₃ alkylene.

15 These ethoxylated cationic polyamines can be derived from polyamino amides such as:

15

20

25

30

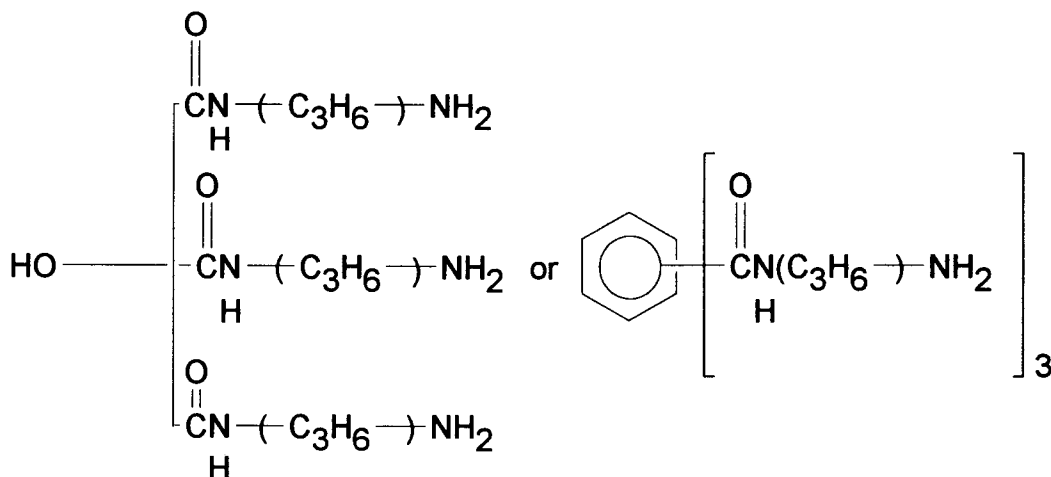

35 These ethoxylated cationic polyamines can also be derived from polyaminopropyleneoxide derivatives such as:

35

40

45

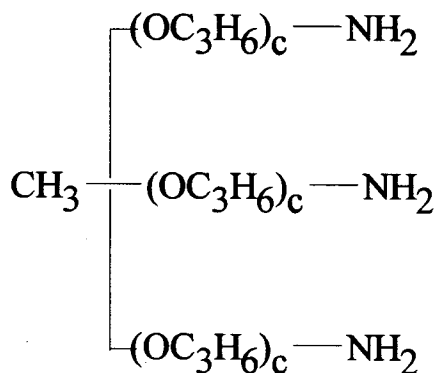

50 wherein each c is a number from 2 to about 20.

The water soluble cationic polymers of the present invention comprises a polymer backbone, at least 2M groups and at least one L-X group, wherein M is a cationic group attached to or integral with the backbone; X is a nonionic group selected from the group consisting of H, C₁-C₄ alkyl or hydroxyalkyl ester or ether groups, and mixtures thereof; and L is a hydrophilic chain connecting groups M and X or connecting X to the polymer backbone.

55 As used herein, the term "polymer backbone" refers to the polymeric moiety to which groups M and L-X are attached or are integral with. Included within this term are oligomer backbones (2 to 4 units), and true polymer backbones (5 or more units).

As used herein, the term "attached to" means that the group is pendent from the polymer backbone, examples of

such attachment being represented by the following general structures A and B:

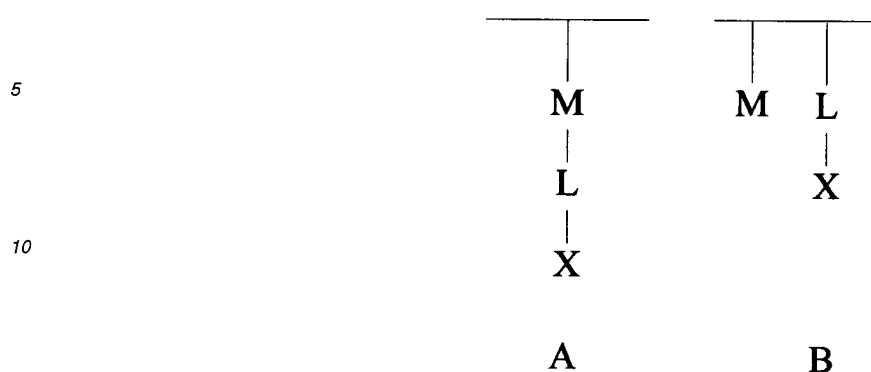

As used herein, the term "integral with" means that the group forms part of the polymer backbone, examples of which are represented by the following general structures C and D:

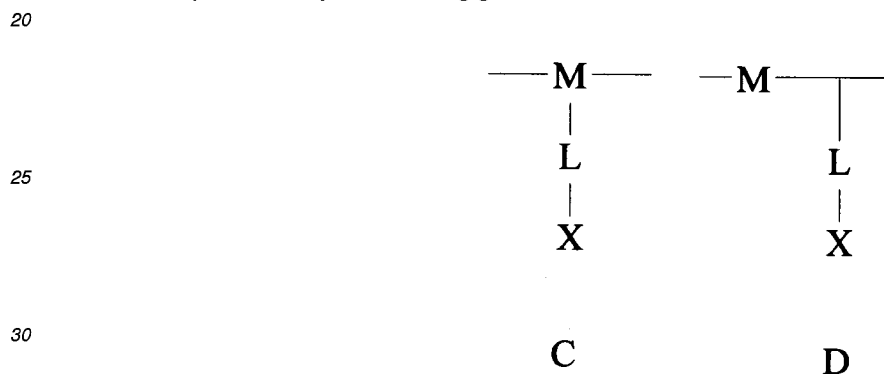

35 Any polymer backbone can be used as long as the cationic polymer formed is water-soluble and has soil removal/anti-redeposition properties. Suitable polymer backbones can be derived from the polyurethanes, the polyesters, the polyethers, the polyamides, the polyimides and the like, the polyacrylates, the polyacrylamides, the polyvinylethers, the polyethylenes, the polypropylenes and like polyalkylenes, the polystyrenes and like polyalkarylenes, the polyalkyleneamines, the polyalkyleneimines, the polyvinylamines, the polyalylamines, the polydiallylamines, the polyvinylpyridines, the polyaminotriazoles, polyvinyl alcohol, the aminopolyureylenes, and mixtures thereof.

40 M can be any compatible cationic group which comprises an N⁺ (quarternary), positively charged center. The quarternary positively charged center can be represented by the following general structures E and F:

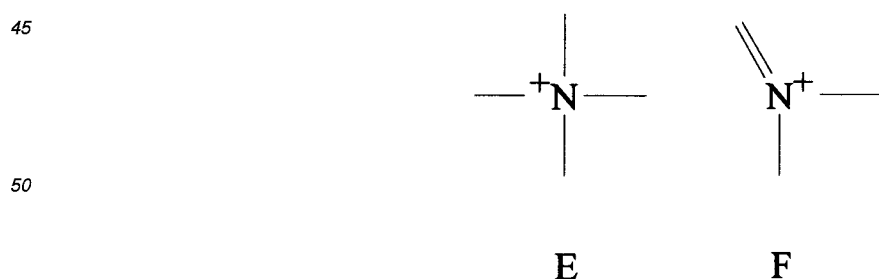

Particularly preferred M groups are those containing a quarternary center represented by general structure E. The cationic group is preferably positioned close to or integral with the polymer backbone.

The positive charge of the N^+ centres is offset by the appropriate number of counter anions. Suitable counter anions include $C1^-$, Br^- , SO_3^{2-} , SO_4^{2-} , PO_4^{2-} , $MeOSO_3^-$ and the like. Particularly preferred counter anions are $C1^-$ and Br^- .

X can be a nonionic group selected from hydrogen (H), C_1 - C_4 alkyl or hydroxyalkyl ester or ether groups, and mixtures thereof. The preferred ester or ether groups are the acetate ester and methyl ether, respectively; The particularly preferred nonionic groups are H and the methyl ether.

The cationic polymers suitable for use in compositions in accord with the present inventions normally have a ratio of cationic groups M to nonionic groups X of from about 1:1 to about 1:2. However, for example, by appropriate copolymerization of cationic, nonionic (i.e. containing the group L-X), and mixed cationic/nonionic monomers, the ratio of cationic groups M to nonionic groups X can be varied. The ratio of groups M to groups X can usually range from about 2:1 to about 1:10. In preferred cationic polymers, the ratio is from about 1:1 to about 1:5. The polymers formed from such copolymerization are typically random, i.e. the cationic, nonionic and mixed cationic/nonionic monomers copolymerize in a nonrepeating sequence.

The units which contain groups M and groups L-X can comprise 100% of the cationic polymers of the present invention. However, inclusion of other units (preferably nonionic) in the polymers is also permissible. Examples of other units include acrylamides, vinyl ethers and those containing unquaternized tertiary amine groups (M^1) containing an N centre. These other units can comprise from 0% to about 90% of the polymer (from about 10% to 100% of the polymer being units containing M and L-X groups, including M^1 -L-X groups). Normally, these other units comprise from 0% to about 50% of the polymer (from about 50% to 100% of the polymer being units containing M and L-X groups).

The number of groups M and L-X each usually ranges from about 2 to about 200. Typically the number of groups M and L-X are each from about 3 to about 100. Preferably, the number of groups M and L-X are each from about 3 to about 40.

Other than moieties for connecting groups M and X, or for attachment to the polymer backbone, hydrophilic chain L usually consists entirely of the polyoxyalkylene moiety $-[(R'O)_m(CH_2CH_2O)_n]-$. The moieties $-(R'O)_m-$ and $-(CH_2CH_2O)_n-$ of the polyoxyalkylene moiety can be mixed together, or preferably form blocks of $-(R'O)_m-$ and $-(CH_2CH_2O)_n-$ moieties. R' is preferably C_3H_6 (propylene); m is preferably from 0 to 5, and most preferably 0; i.e. the polyoxyalkylene moiety consists entirely of the moiety $-(CH_2CH_2O)_n-$. The moiety $-(CH_2CH_2O)_n-$ preferably comprises at least about 85% by weight of the polyoxyalkylene moiety, and most preferably 100% by weight (m is 0).

For the moiety $-(CH_2CH_2O)_n-$, n is usually from 3 to 100. Preferably, n is from 12 to 42.

A plurality (2 or more) of moieties -L-X can also be hooked together and attached to group M or to the polymer backbone, examples of which are represented by the following general structures G and H:

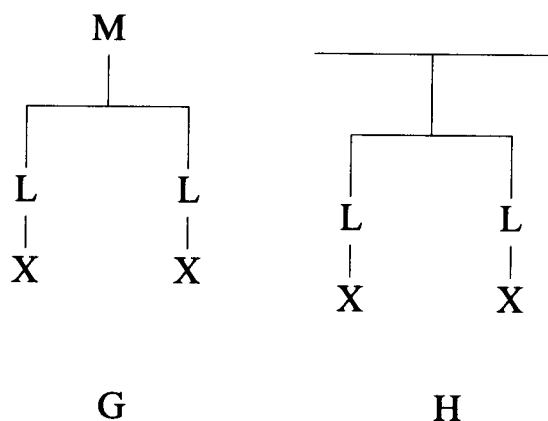

Structures such as G and H can be formed, for example, by reacting glycidol with group M or with the polymer backbone, and ethoxylating the subsequently formed hydroxy groups.

Representative classes of cationic polymers of the present invention are as follows:

A. Polyurethane, Polyester, Polyether, Polyamide or like Polymers.

One class of suitable cationic polymers are derived from polyurethanes, polyesters, polyethers, polyamides and the like. These polymers comprise units selected from those having formulas I, II and III:

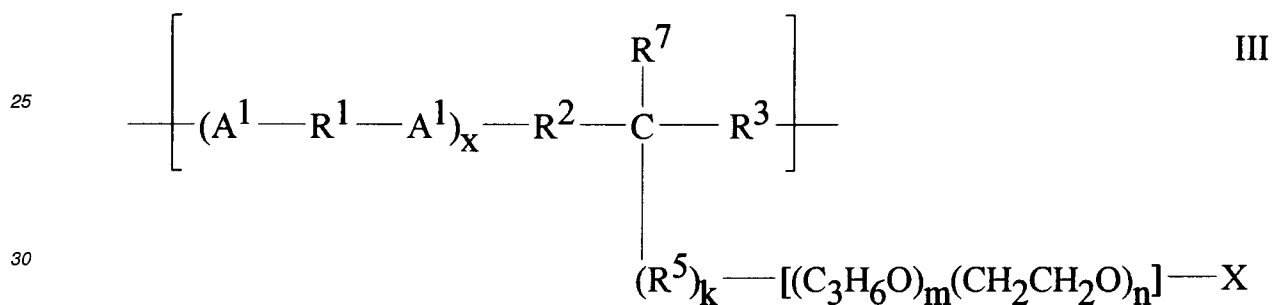
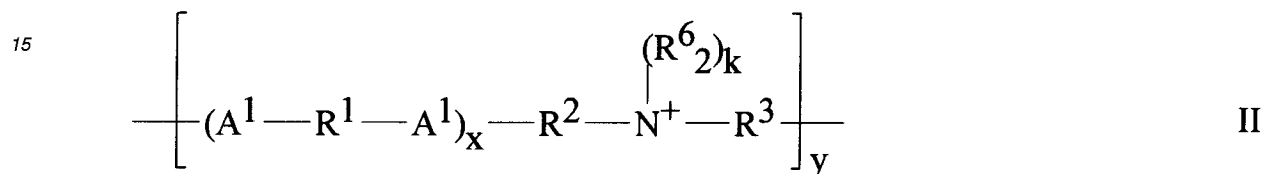
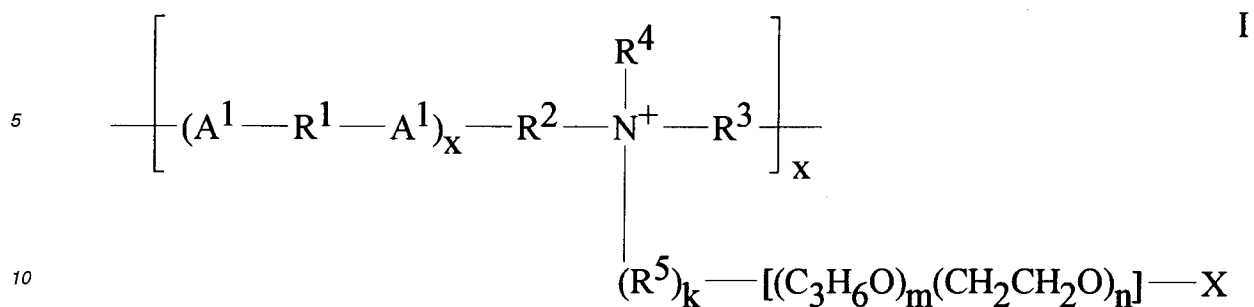

wherein A¹ is

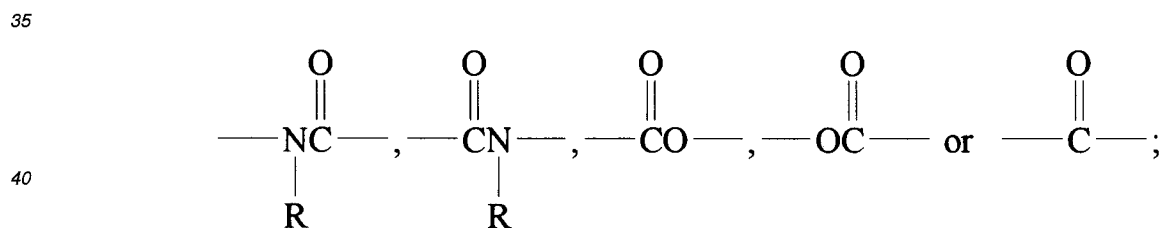

45 X is 0 or 1; R is H or C₁-C₄ alkyl or hydroxyalkyl; R¹ is C₂-C₁₂ alkylene, hydroxyalkylene, alkenylene, cycloalkylene, arylene or alkarylene, or a C₂-C₃ oxyalkylene moiety having from 2 to about 20 oxyalkylene units provided that no O-O or O-N bonds are formed with A¹; when x is 1, R² is -R⁵- except when A¹ is



or is -(OR⁸)_y- or -OR⁵- provided that no O-O or N-O bonds are formed with A¹, and R³ is -R⁵- except when A¹ is

55

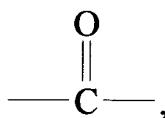

5

or is $-(R^8O)_y-$ or $-R^5O-$ provided that no O-O or O-N bonds are formed with A^1 ; when x is 0, R^2 is

10

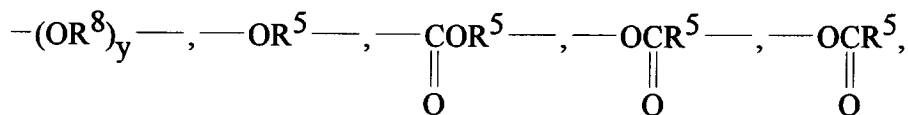

15

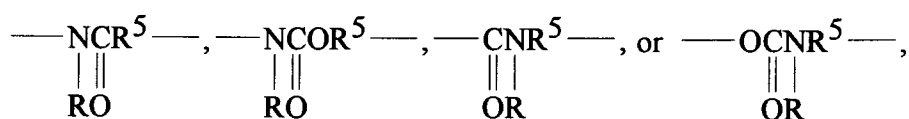

20

and R^3 is $-R^5-$; R^4 is C_1 - C_4 alkyl or hydroxyalkyl, or the moiety $-(R^5)_k-[(C_3H_6O)_m(CH_2CH_2O)_n]-X$; R^5 is C_1 - C_{12} alkylene, hydroxyalkylene, alkenylene, arylene, or alkarylene; each R^6 is C_1 - C_4 alkyl or hydroxyalkyl, or the moiety $-(CH_2)_r-A^2-(CH_2)_s-$, wherein A^2 is $-O-$ or $-CH_2-$; R^7 is H or R^4 ; R^8 is C_2 - C_3 alkylene or hydroxyalkylene; X is H,

25

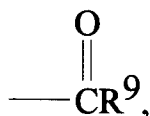

30

$-R^9$ or a mixture thereof, wherein R^9 is C_1 - C_4 alkyl or hydroxyalkyl; k is 0 or 1; m and n are numbers such that the moiety $-(CH_2CH_2O)_n$ comprises at least about 85% by weight of the moiety $-(C_3H_6O)_m(CH_2CH_2O)_n$; m is from 0 to about 5; n is at least about 3; r is 1 or 2, s is 1 or 2, and r + s is 3 or 4; y is from 2 to about 20; the number of u, v and w are such that there are at least 2 N^+ centers and at least 2 X groups.

35

In the above formulas, A^1 is preferably

40

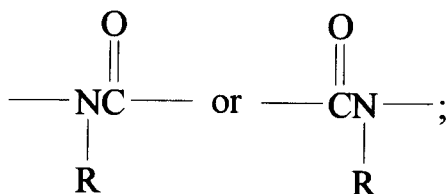

45

A^2 is preferably $-O-$; x is preferably 1; and R is preferably H. R^1 can be linear (e.g. $-CH_2-CH_2-CH_2-$,

50

55

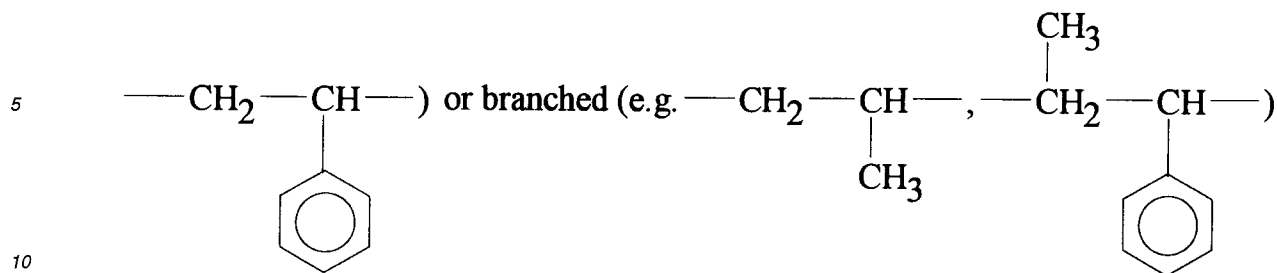

alkylene, hydroxyalkylene, alkenylene, cycloalkylene, alkarylene or oxyalkylene; when R^1 is a $C_2\text{---}C_3$ oxyalkylene moiety, the number of oxyalkylene units is preferably from about 2 to about 12; R^1 is preferably $C_2\text{---}C_6$ alkylene or phenylene, and most preferably $C_2\text{---}C_6$ alkylene (e.g. ethylene, propylene, hexamethylene). R^2 is preferably $\text{---OR}^5\text{---}$ or $\text{---(OR}^8\text{)}_y\text{---}$; R^3 is preferably $\text{---R}^5\text{O---}$ or $\text{---(OR}^8\text{)}_y\text{---}$; R^4 and R^6 are preferably methyl. Like R^1 , R^5 can be linear or branched, and is preferably $C_2\text{---}C_3$ alkylene; R^7 is preferably H or $C_1\text{---}C_3$ alkyl; R^8 is preferably ethylene; R^9 is preferably methyl; X is preferably H or methyl; k is preferably 0; m is preferably 0, r and s are each preferably 2; y is preferably from 2 to about 12.

20 In the above formulas, n is preferably at least about 6 when the number of N^+ centers and X groups is 2 or 3; n is most preferably at least about 12, with a typical range of about 12 to about 42 for all ranges of $u + v + w$. For homopolymers (v and w are 0), u is preferably from about 3 to about 20. For random copolymers (u is at least 1 or preferably 0), v and w are each preferably from about 3 to about 40.

25 B. Polyacrylate, Polyacrylamide, Polyvinylether or like Polymers

Another class of suitable cationic polymers are derived from polyacrylates, polyacrylamides, polyvinylethers and the like. These polymers comprise units selected from those having formulas IV, V and VI.

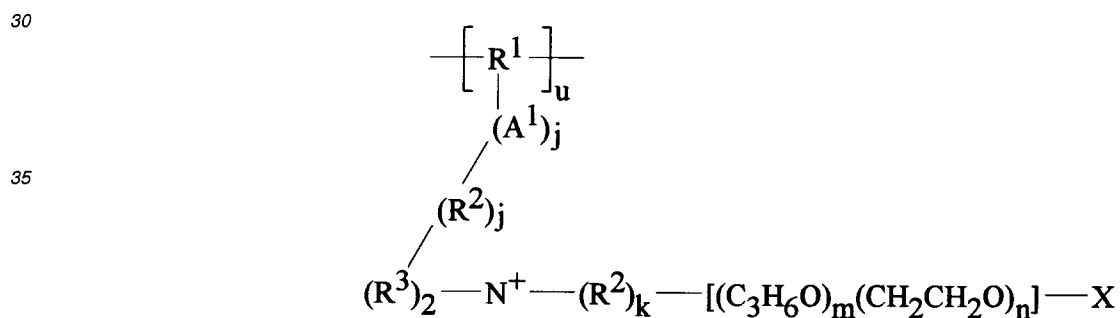

IV

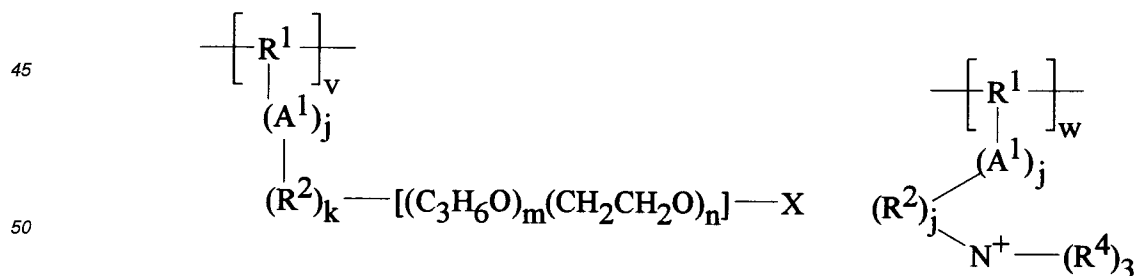

V

VI

55 wherein A^1 is

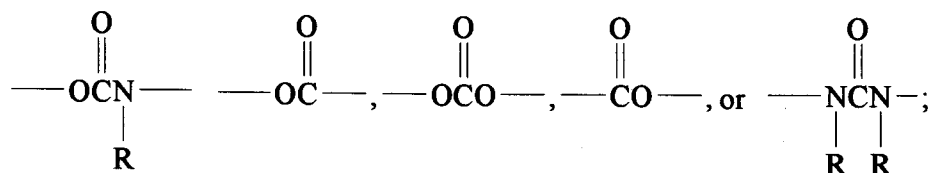
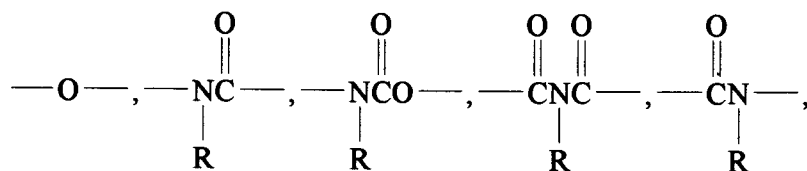

R is H or C₁-C₄ alkyl or hydroxyalkyl; R¹ is substituted C₂-C₁₂ alkylene, hydroxyalkylene, alkenylene, arylene or alkarylene, or C₂-C₃ oxyalkylene; each R² is C₁-C₁₂ alkylene, hydroxyalkylene, alkenylene, arylene or alkarylene; each R³ is C₁-C₄ alkyl or hydroxyalkyl, the moiety -(R²)_k-[(C₃H₆O)_m(CH₂CH₂O)_n]-X, or together form the moiety -(CH₂)_r-A²-(CH₂)_s-, wherein A² is -O- or -CH₂-; each R⁴ is C₁-C₄ alkyl or hydroxyalkyl, or two R⁴ together form the moiety -(CH₂)_r-A²-(CH₂)_s-; X is H,

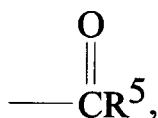

-R⁵ or mixture thereof, wherein R⁵ is C₁-C₄ alkyl or hydroxyalkyl; j is 1 or 0; k is 1 or 0; m and n are numbers such that the moiety -(CH₂CH₂O)_n- comprises at least about 85% by weight of the moiety -[(C₃H₆O)_m(CH₂CH₂O)_n]-; m is from 0 to about 5; n is at least about 3; r is 1 or 2, s is 1 or 2 and r + s is 3 or 4; the number of u, v and w are such that there are at least 2N+ centres and at least 2 X groups.

In the above formulas, A¹ is preferably

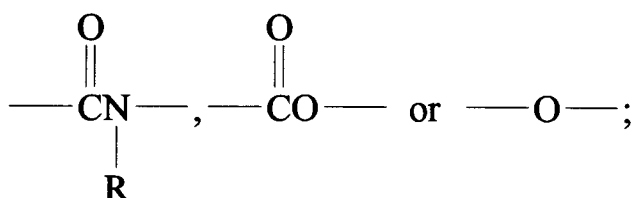

A² is preferably -O-; R is preferably H. R¹ can be linear

(e.g. $\text{---CH}_2\text{---CH---CH}_2\text{---}$, $\text{---CH}_2\text{CH---}$) or

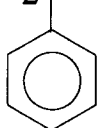

CH_3

10 branched (e.g. $\text{---CH}_2\text{---C---}$, $\text{---CH}_2\text{CH---}$,

CH_3

CH_3

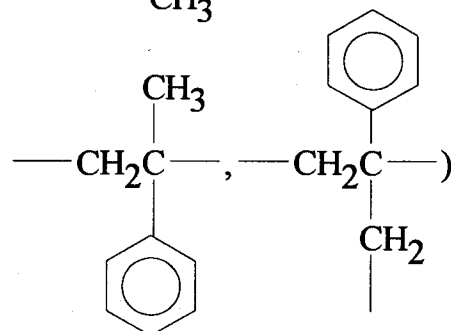

20

25

substituted alkylene, hydroxyalkylene, alkenylene, alkarylene or oxyalkylene; R^1 is preferably substituted $\text{C}_2\text{---C}_6$ alkylene or substituted $\text{C}_2\text{---C}_3$ oxyalkylene, and most preferably

30

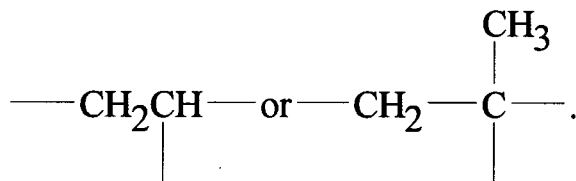

Each R^2 is preferably $\text{C}_2\text{---C}_3$ alkylene, each R^3 and R^4 are preferably methyl; R^5 is preferably methyl; X is preferably H or methyl; j is preferably 1; k is preferably 0; m is preferably 0; r and s are each preferably 2.

40 In the above formulas, n, u, v and w can be varied according to the n, u, v and w for the polyurethane and like polymers.

C. Polyalkyleneamine, Polyalkyleneimine or like polymers.

45 Another class of suitable cationic polymers are derived from polyalkyleneamines, polyalkyleneimines and the like. These polymers comprise units selected from those having formulas VII and VIII and IX.

50

55

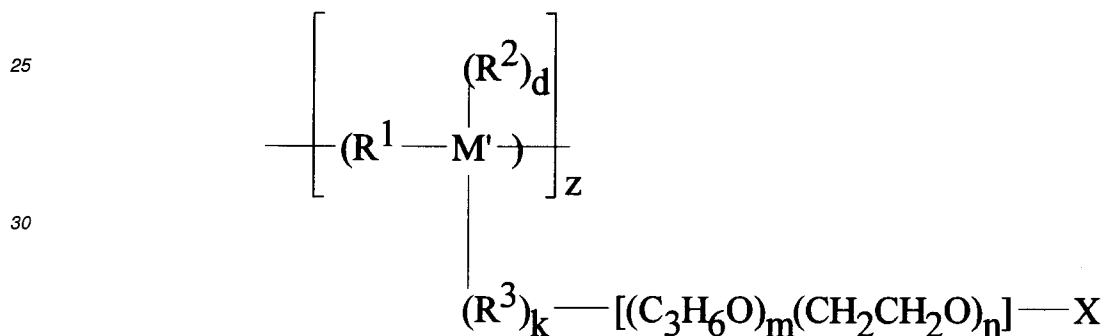
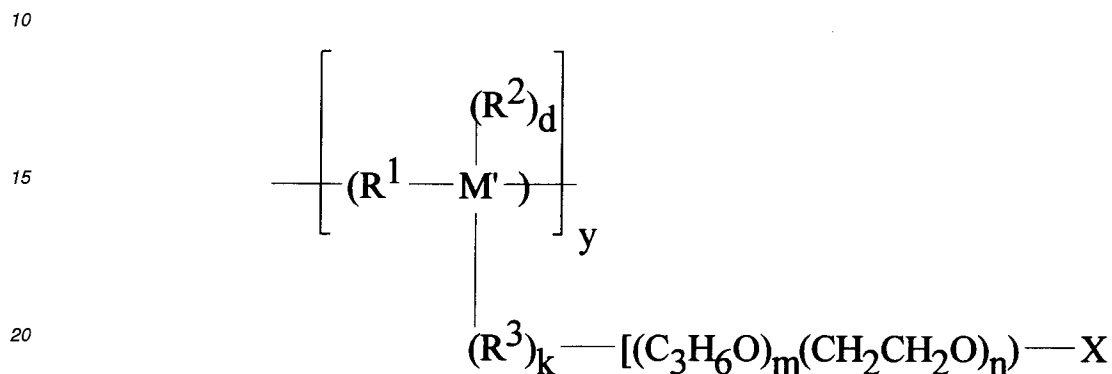
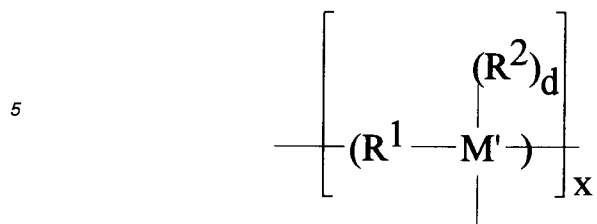

35 wherein R¹ is C₂-C₁₂ alkylene, hydroxyalkylene, alkenylene, cycloalkylene, arylene or alkarylene, or a C₂-C₃ oxy-alkylene moiety having from 2 to about 20 oxyalkylene units provided that no O-N bonds are formed; each R² is C₁-C₄ alkyl or hydroxyalkyl, or the moiety -(R³)_k[(C₃H₆O)_m(CH₂CH₂O)_n]-X; R³ is C₁-C₁₂ alkylene, hydroxyalkylene, alkenylene, arylene or alkarylene; M' is an N⁺ or N centre; X is H,



45 -R⁴ or mixture thereof, wherein R⁴ is C₁-C₄ alkyl or hydroxyalkyl; d is 1 when M' is N⁺ and is 0 when M' is N; e is 2 when M' is N⁺ and is 1 when M' is N; k is 1 or 0; m and n are numbers such that the moiety -(CH₂CH₂O)_n- comprises at least about 85% by weight of the moiety -[(C₃H₆O)_m(CH₂CH₂O)_n]-; m is from 0 to about 5; n is at least about 3; the number of x, y and z are such that there are at least 2M' groups, at least 2N⁺ centres and at least 2 X groups.

In the above formulas, R¹ can be varied like R¹ of the polyurethane and like polymers; each R² is preferably methyl or the moiety -(R³)_k[(C₃H₆O)_m(CH₂CH₂O)_n]-X; R³ is preferably C₂-C₃ alkylene; R⁴ is preferably methyl; X is preferably H; k is preferably 0; m is preferably 0.

55 In the above formulas, n is preferably at least about 6 when the number of M' and X groups is 2 or 3; n is most preferably at least about 12, with a typical range of from about 12 to about 42 for all ranges of x + y + z. Typically, x + y + z is from 2 to about 40 and preferably from 2 to about 20. For short chain length polymers, x + y + z can range from 2 to 9 with from 2 to 9 N⁺ centres and from 2 to 11 X groups. For long chain length polymers, x + y + z is at least 10, with

a preferred range of from 10 to about 42. For the short and long chain length polymers, the M' groups are typically a mixture of from about 50 to 100% N+ centres and from 0 to about 50% N centres.

Preferred cationic polymers within this class are derived from the C₂-C₃ polyalkyleneamines (x + y + z is from 2 to 9) and polyalkyleneimines (x + y + z is at least 10, preferably from 10 to about 42). Particularly preferred cationic polyalkyleneamines and polyalkyleneimines are the cationic polyethyleneamines (PEA's) and polyethyleneimines (PEI's). These preferred cationic polymers comprise units having the general formula:

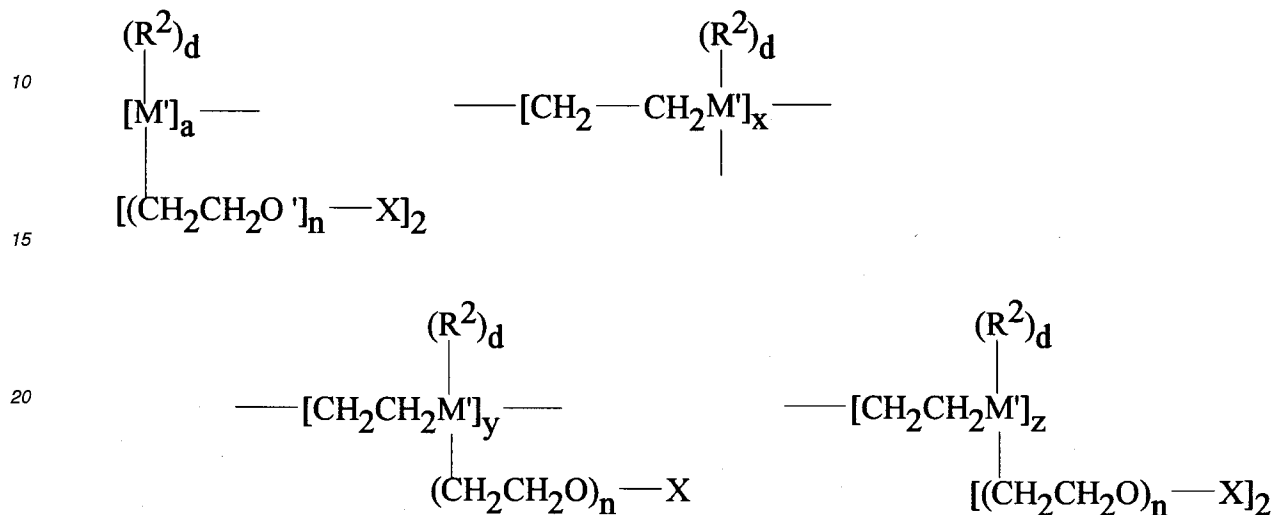

wherein R² (preferably methyl), M', X, d, x, y, z and n are defined as before; a is 1 or 0.

Prior to ethoxylation, the PEAs used in preparing cationic polymers of the present invention have the following general formula:

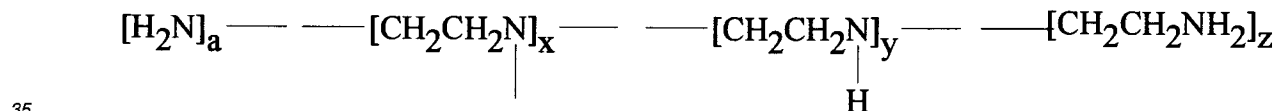

wherein x + y + z is from 2 to 9, and a is 0 or 1 (molecular weight of from about 100 to about 400). Each hydrogen atom attached to each nitrogen atom represents an active site for subsequent ethoxylation. For preferred PEAs, x + y + z is from about 3 to about 7 (molecular weight is from about 140 to about 310). These PEA's can be obtained by reactions involving ammonia and ethylene dichloride, followed by fractional distillation. The common PEA's obtained are triethylenetetramine (TETA) and tetraethylenepentamine (TEPA). Above the pentamines, i.e., the hexamines, heptamines, octamines and possibly nonamines, the cogenerally derived mixture does not appear to separate by distillation and can include other materials such as cyclic amines and particularly piperazines. There can also be present cyclic amines with side chains in which nitrogen atoms appear. See US Pat. No. 2,792,372 to Dickson, issues May 14, 1957, which describes the preparation of PEAs.

The minimum degree of ethoxylation required for preferred soil removal/anti-redeposition performance can vary depending upon the number of units in the PEA. Where y + z is 2 or 3, n is preferably at least about 6. Where y + z is from 4 to 9, suitable benefits are achieved when n is at least about 3. For preferred cationic PEAs, n is at least about 12, with a typical range of about 12 to about 42.

The PEIs used in preparing the polymers of the present invention have a molecular weight of at least about 440 prior to ethoxylation, which represents at least about 10 units. Preferred PEIs used in preparing these polymers have a molecular weight of from about 600 to about 1800. The polymer backbone of these PEIs can be represented by the general formula:

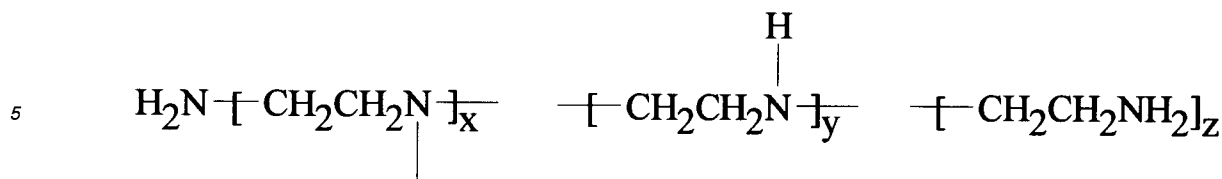

wherein the sum of x, y, and z represents a number of sufficient magnitude to yield a polymer having the molecular weights previously specified. Although linear polymer backbones are possible, branch chains can also occur. The relative proportions of primary, secondary and tertiary amine groups present in the polymer can vary, depending on the manner of preparation. The distribution of amine groups is typically as follows:

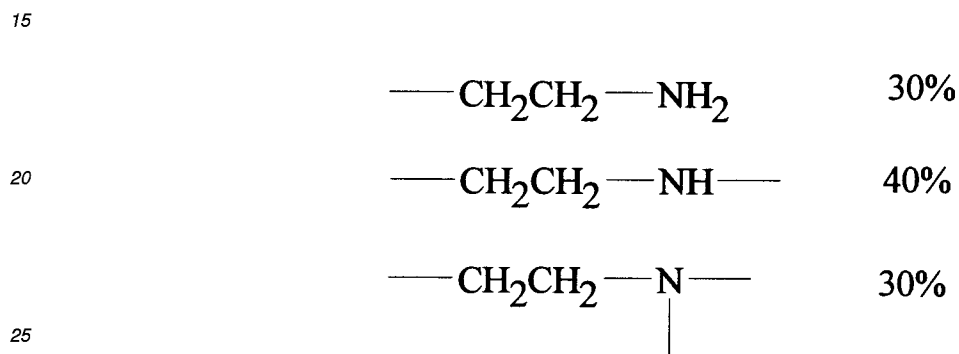

Each hydrogen atom attached to each nitrogen atom of the PEI represents an active site for subsequent ethoxylation. These PEIs can be prepared, for example, by polymerizing ethyleneimine in the presence of a catalyst such as carbon dioxide, sodium bisulfite, sulfuric acid, hydrogen peroxide, hydrochloric acid, acetic acid, etc. Specific methods for preparing PEIs are disclosed in US Pat. No. 2,182,306 to Ulrich et al., issued Dec. 5, 1939; US Pat. No. 3,033,746 to Mayle et al., issued May 8, 1962; US Pat. No. 2,208,095 to Esselmann et al., issued July 16, 1940; US Pat. No. 2,806,839 to Crowther, issued Sept. 17, 1957; and US Pat. No. 2,533,696 to Wilson, issued May 21, 1951 (all herein incorporated by reference).

As defined in the preceding formulas, n is at least about 3 for the cationic PEIs. However, it should be noted that the minimum degree of ethoxylation required for suitable soil removal/anti-redeposition performance can increase as the molecular weight of the PEI increases, especially much beyond about 1800. Also, the degree of ethoxylation for preferred polymers increases as the molecular weight of the PEI increases. For PEIs having a molecular weight of at least about 600, n is preferably at least about 12, with a typical range of from about 12 to about 42. For PEIs having a molecular weight of at least 1800, n is preferably at least about 24, with a typical range of from about 24 to about 42.

D. Diallylamine Polymers

Another class of suitable cationic polymers are those derived from the diallylamines. These polymers comprise units selected from those having formulas X and XI:

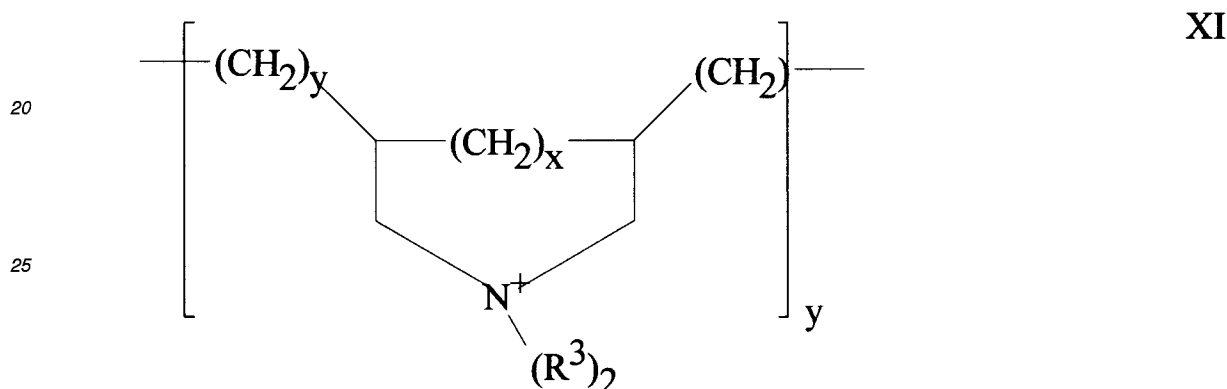
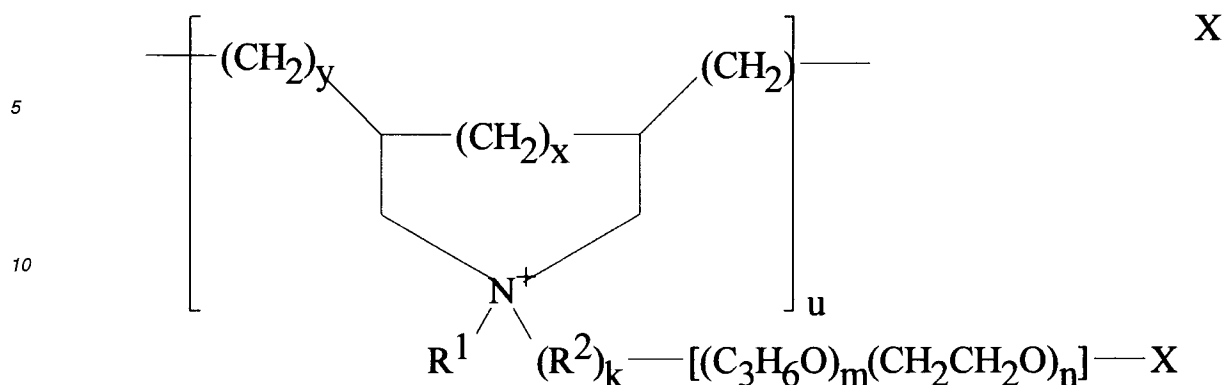

wherein R^1 is C_1 - C_4 alkyl or hydroxyalkyl, or the moiety $-(R^2)_k[(C_3H_6O)_m(CH_2CH_2O)_n]-X$; R^2 is C_1 - C_{12} alkylene, hydroxyalkylene, alkylene, arylene or alkarylene; each R^3 is C_1 - C_4 alkyl or hydroxyalkyl, or together form the moiety $-(CH_2)_r-A-(CH_2)_s-$, wherein A is $-O-$ or $-CH_2-$; X is H,

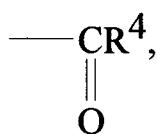

$-R^4$ or mixture thereof, wherein R^4 is C_1 - C_4 alkyl or hydroxyalkyl; k is 1 or 0; m and n are numbers such that the moiety $-(CH_2CH_2O)_n-$ comprises at least about 85% by weight of the moiety $-(C_3H_6O)_m(CH_2CH_2O)_n-$; m is from 0 to about 5; n is at least about 3; r is 1 or 2, s is 1 or 2, and $r + s$ is 3 or 4; x is 1 or 0; y is 1 when x is 0 and 0 when x is 1; the number of u and v are such that there are at least $2N+$ centres and at least 2 X groups.

In the above formulas, A is preferably $-O-$; R^1 is preferably methyl; each R^2 is preferably C_2 - C_3 alkylene; each R^3 is preferably methyl; R^4 is preferably methyl; X is preferably H; k is preferably 0; m is preferably 0; r and s are each preferably 2.

In the above formulas, n is preferably at least about 6 when the number of $N+$ centres and X groups are each 2 or 3, n is preferably at least 12, with a typical range of from about 12 to about 42 for all range of $u + v$. Typically, v is 0, and u is from 2 to about 40, and preferably from 2 to about 20.

The compositions according to the present invention comprise from 0.01% to 10% by weight of the total composition of such a soil suspending agent or mixtures thereof, preferably from 0.05% to 5%, more preferably 0.1% to 4% and most preferably from 0.2% to 2%.

The aqueous compositions according to the present invention are formulated in the acidic pH range. Indeed acidity herein contributes to the stain removal/bleaching benefit of the compositions of the present invention. Indeed, the compositions herein have a pH below 6, more preferably below 5, even more preferably from 1 to 4.5 and most preferably from 2 to 4.5.

The compositions according to the present invention may comprise optional ingredients like surfactants, bleach activators, stabilisers, cheating agents, radical scavengers, builders, soil suspenders, dye transfer agents, solvents, brighteners, perfumes, foam suppressors, dyes or mixtures thereof. Preferred optional ingredients are further described in more details hereinafter.

5

The laundry pretreatment process

In its broadest embodiment, the present invention relates to a process of pretreating a fabric with a liquid acidic aqueous composition as described herein before.

10 By "pretreating a fabric" it is to be understood that the liquid aqueous composition herein is applied in its neat form onto at least a portion of a soiled fabric, optionally left to act onto said fabric typically for a period of time of 1 minute to several hours, before said fabric is washed, as described hereinafter, in the process of bleaching fabrics according to the present invention.

15 Accordingly, the present invention encompasses a process of bleaching a fabric with a liquid aqueous composition, as defined herein before, said process comprises the steps of applying said composition in its neat form onto at least a portion of said fabric, optionally allowing said composition to remain in contact with said fabric preferably without leaving said composition to dry onto said fabric, before said fabric is washed.

20 Said composition may remain in contact with said fabric, typically for a period of 1 minute to several hours, preferably 1 minute to 1 hour, more preferably 1 minute to 30 minutes, and most preferably 2 to 10 minutes. Optionally, when the fabric is soiled with encrusted stains/soils which otherwise would be relatively difficult to remove, said composition may be rubbed and/or brushed more or less intensively, for example, by means of a sponge or a brush or simply by rubbing two pieces of fabric each against the other.

25 By "washing" it is to be understood herein to simply rinse the fabric with water, or the fabric may be washed with a conventional composition comprising at least one surface active agent, this by the means of a washing machine or simply by hand.

By "in its neat form" it is to be understood that the liquid aqueous compositions are applied directly onto the fabrics to be pre-treated without undergoing any dilution, e.g., the liquid aqueous compositions according to the present invention are applied as described herein.

30 According to the process of pretreating soiled fabrics of the present invention, the liquid aqueous compositions used in said process should preferably not be left to dry onto the fabrics. Indeed, it has been found that water evaporation contributes to increase the concentration of free radicals onto the surface of the fabrics and, consequently, the rate of chain reaction. It is also speculated that an auto-oxidation reaction occurs upon evaporation of water when the liquid compositions are left to dry onto the fabrics. Said reaction of auto-oxidation contributes to generate peroxy-radicals which may cause color damage and/or fabric damage. Thus, not leaving the liquid aqueous bleaching compositions used according to the present invention to dry onto the fabrics, in the process of bleaching fabrics according to the present invention would result in a safer pretreating operation with liquid aqueous bleaching compositions.

Optional ingredients

40 The compositions of the present invention may further comprise optional ingredients like surfactants, bleach activators, stabilisers, chelating agents, radical scavengers, builders, soil suspenders, dye transfer agents, solvents, brighteners, perfumes, foam suppressors, or dyes or mixtures thereof.

45 Accordingly, the liquid aqueous compositions of the present invention preferably comprise a surfactant or mixtures thereof. Any surfactant known to those skilled in the art may be suitable herein including nonionic, anionic, cationic, zwitterionic, and/or amphoteric surfactants up to 50% by weight of the total composition. Surfactants allow to further improve the stain removal properties of the compositions according to the present invention.

50 Nonionic surfactants are highly preferred herein for performance reasons. The liquid compositions herein may comprise up to 50% of a nonionic surfactant or mixtures thereof, preferably from 0.3% to 30% and more preferably from 0.4% to 25%. Suitable nonionic surfactants to be used herein are fatty alcohol ethoxylates and/or propoxylates which are commercially available with a variety of fatty alcohol chain lengths and a variety of ethoxylation degrees. Indeed, the HLB values of such alkoxyated nonionic surfactants depend essentially on the chain length of the fatty alcohol, the nature of the alkoxylation and the degree of alkoxylation. Surfactant catalogues are available which list a number of surfactants, including nonionics, together with their respective HLB values.

55 Suitable chemical processes for preparing the nonionic surfactants for use herein include condensation of corresponding alcohols with alkylene oxide, in the desired proportions. Such processes are well-known to the man skilled in the art and have been extensively described in the art. As an alternative, a great variety of alkoxyated alcohols suitable for use herein is commercially available from various suppliers.

Particularly suitable to be used herein as nonionic surfactants are hydrophobic nonionic surfactants having an HLB

(hydrophilic-lipophilic balance) below 16, preferably below 15, more preferably below 12, and most preferably below 10. Those hydrophobic nonionic surfactants have been found to provide good grease cutting properties.

Preferred hydrophobic nonionic surfactants to be used in the compositions according to the present invention are surfactants having an HLB below 16 and being according to the formula $RO-(C_2H_4O)_n(C_3H_6O)_mH$, wherein R is a C_6 to C_{22} alkyl chain or a C_6 to C_{28} alkyl benzene chain, and wherein $n+m$ is from 0 to 20 and n is from 0 to 15 and m is from 0 to 20, preferably $n+m$ is from 1 to 15 and, n and m are from 0.5 to 15, more preferably $n+m$ is from 1 to 10 and, n and m are from 0 to 10. The preferred R chains for use herein are the C_8 to C_{22} alkyl chains. Accordingly, suitable hydrophobic nonionic surfactants for use herein are Dobanol^R 91-2.5 (HLB= 8.1; R is a mixture of C_9 and C_{11} alkyl chains, n is 2.5 and m is 0), or Lutensol^R TO3 (HLB=8; R is a C_{13} alkyl chains, n is 3 and m is 0), or Lutensol^R AO3 (HLB=8; R is a mixture of C_{13} and C_{15} alkyl chains, n is 3 and m is 0), or Tergitol^R 25L3 (HLB= 7.7; R is in the range of C_{12} to C_{15} alkyl chain length, n is 3 and m is 0), or Dobanol^R 23-3 (HLB=8.1; R is a mixture of C_{12} and C_{13} alkyl chains, n is 3 and m is 0), or Dobanol^R 23-2 (HLB=6.2; R is a mixture of C_{12} and C_{13} alkyl chains, n is 2 and m is 0), or Dobanol^R 45-7 (HLB=11.6; R is a mixture of C_{14} and C_{15} alkyl chains, n is 7 and m is 0) Dobanol^R 23-6.5 (HLB=11.9; R is a mixture of C_{12} and C_{13} alkyl chains, n is 6.5 and m is 0), or Dobanol^R 25-7 (HLB=12; R is a mixture of C_{12} and C_{15} alkyl chains, n is 7 and m is 0), or Dobanol^R 91-5 (HLB=11.6; R is a mixture of C_9 and C_{11} alkyl chains, n is 5 and m is 0), or Dobanol^R 91-6 (HLB=12.5 ; R is a mixture of C_9 and C_{11} alkyl chains, n is 6 and m is 0), or Dobanol^R 91-8 (HLB=13.7 ; R is a mixture of C_9 and C_{11} alkyl chains, n is 8 and m is 0), Dobanol^R 91-10 (HLB=14.2 ; R is a mixture of C_9 to C_{11} alkyl chains, n is 10 and m is 0), or mixtures thereof. Preferred herein are Dobanol^R 91-2.5 , or Lutensol^R TO3, or Lutensol^R AO3, or Tergitol^R 25L3, or Dobanol^R 23-3, or Dobanol^R 23-2, or mixtures thereof. These Dobanol^R surfactants are commercially available from SHELL. These Lutensol^R surfactants are commercially available from BASF and these Tergitol^R surfactants are commercially available from UNION CARBIDE.

Other suitable nonionic surfactants for use herein include polyhydroxy fatty acid amide surfactants, or mixtures thereof, according to the formula



wherein R^1 is H, or C_1 - C_4 alkyl, C_1 - C_4 hydrocarbyl, 2-hydroxy ethyl, 2-hydroxy propyl or a mixture thereof, R^2 is C_5 - C_{31} hydrocarbyl, and Z is a polyhydroxyhydrocarbyl having a linear hydrocarbyl chain with at least 3 hydroxyls directly connected to the chain, or an alkoxyated derivative thereof.

Preferably, R^1 is C_1 - C_4 alkyl, more preferably C_1 or C_2 alkyl and most preferably methyl, R^2 is a straight chain C_7 - C_{19} alkyl or alkenyl, preferably a straight chain C_9 - C_{18} alkyl or alkenyl, more preferably a straight chain C_{11} - C_{18} alkyl or alkenyl, and most preferably a straight chain C_{11} - C_{14} alkyl or alkenyl, or mixtures thereof. Z preferably will be derived from a reducing sugar in a reductive amination reaction; more preferably Z is a glycityl. Suitable reducing sugars include glucose, fructose, maltose, lactose, galactose, mannose and xylose. As raw materials, high dextrose corn syrup, high fructose corn syrup, and high maltose corn syrup can be utilised as well as the individual sugars listed above. These corn syrups may yield a mix of sugar components for Z. It should be understood that it is by no means intended to exclude other suitable raw materials. Z preferably will be selected from the group consisting of $-CH_2-(CHOH)_n-CH_2OH$, $-CH(CH_2OH)-(CHOH)_{n-1}-CH_2OH$, $-CH_2-(CHOH)_2-(CHOR)(CHOH)-CH_2OH$, where n is an integer from 3 to 5, inclusive, and R' is H or a cyclic or aliphatic monosaccharide, and alkoxyated derivatives thereof. Most preferred are glycityls wherein n is 4, particularly $CH_2-(CHOH)_4-CH_2OH$.

In formula $R^2 - C(O) - N(R^1) - Z$, R^1 can be, for example, N-methyl, N-ethyl, N-propyl, N-isopropyl, N-butyl, N-2-hydroxy ethyl, or N-2-hydroxy propyl. $R^2 - C(O) - N<$ can be, for example, cocamide, stearamide, oleamide, lauramide, myristamide, capricamide, palmitamide, tallowamide and the like. Z can be 1-deoxyglucityl, 2-deoxyfructityl, 1-deoxymaltityl, 1-deoxylactityl, 1-deoxygalactityl, 1-deoxymannityl, 1-deoxymaltotriosityl and the like.

Suitable polyhydroxy fatty acid amide surfactants to be used herein may be commercially available under the trade name HOE[®] from Hoechst.

Methods for making polyhydroxy fatty acid amide surfactants are known in the art. In general, they can be made by reacting an alkyl amine with a reducing sugar in a reductive amination reaction to form a corresponding N-alkyl polyhydroxyamine, and then reacting the N-alkyl polyhydroxyamine with a fatty aliphatic ester or triglyceride in a condensation/amidation step to form the N-alkyl, N-polyhydroxy fatty acid amide product. Processes for making compositions containing polyhydroxy fatty acid amides are disclosed for example in GB patent specification 809,060, published February 18, 1959, by Thomas Hedley & Co., Ltd., US patent 2,965,576, issued December 20, 1960 to E.R. Wilson, US patent 2,703,798, Anthony M. Schwartz, issued March 8, 1955, US patent 1,985,424, issued December 25, 1934 to Piggott and WO92/06070, each of which is incorporated herein by reference.

The liquid aqueous compositions according to the present invention may further comprise other surfactants like an anionic surfactant, or mixtures thereof on top of nonionic surfactants. Anionic surfactants are preferred herein as optional ingredient as they act as wetting agent, i.e., in a laundry application they wet the stains on the fabrics, especially on hydrophilic fabrics, and thus help the peroxygen bleach perform its bleaching action thereby contributing to

improved laundry performance on bleachable stains. Furthermore, anionic surfactants allow to obtain clear compositions even when said compositions comprise hydrophobic ingredients such as hydrophobic surfactants. The compositions herein may comprise from 0.1 % to 20 % by weight of the total composition of said anionic surfactant, or mixtures thereof, preferably from 0.2 % to 15 % and more preferably from 0.5 % to 13 %.

5 Particularly suitable for use herein are sulfonate and sulfate surfactants. The like anionic surfactants are well-known in the art and have found wide application in commercial detergents. These anionic surfactants include the C₈-C₂₂ alkyl benzene sulfonates (LAS), the C₈-C₂₂ alkyl sulfates (AS), unsaturated sulfates such as oleyl sulfate, the C₁₀-C₁₈ alkyl alkoxy sulfates (AES) and the C₁₀-C₁₈ alkyl alkoxy carboxylates. The neutralising cation for the anionic synthetic sulfonates and/or sulfates is represented by conventional cations which are widely used in detergent technology such as sodium, potassium or alkanolammonium. Preferred herein are the alkyl sulphate, especially coconut alkyl sulphate having from 6 to 18 carbon atoms in the alkyl chain, preferably from 8 to 15, or mixtures thereof.

10 Other anionic surfactants useful for detergent purposes can also be used herein. These can include salts (including, for example, sodium, potassium, ammonium, and substituted ammonium salts such as mono-, di- and triethanolamine salts) of soap, C₈-C₂₂ primary or secondary alkanesulfonates, C₈-C₂₄ olefinsulfonates, sulfonated polycarboxylic acids prepared by sulfonation of the pyrolyzed product of alkaline earth metal citrates, e.g., as described in British patent specification No. 1,082,179, C₈-C₂₄ alkylpolyglycoethersulfates (containing up to 10 moles of ethylene oxide); alkyl ester sulfonates such as C₁₄₋₁₆ methyl ester sulfonates; acyl glycerol sulfonates, fatty oleyl glycerol sulfates, alkyl phenol ethylene oxide ether sulfates, paraffin sulfonates, alkyl phosphates, isethionates such as the acyl isethionates, N-acyl taurates, alkyl succinamates and sulfosuccinates, monoesters of sulfosuccinate (especially saturated and unsaturated C₁₂-C₁₈ monoesters) diesters of sulfosuccinate (especially saturated and unsaturated C₆-C₁₄ diesters), sulfates of alkylpolysaccharides such as the sulfates of alkylpolyglucoside (the nonionic nonsulfated compounds being described below). Resin acids and hydrogenated resin acids are also suitable, such as rosin, hydrogenated rosin, and resin acids and hydrogenated resin acids present in or derived from tall oil. Further examples are given in "Surface Active Agents and Detergents" (Vol. I and II by Schwartz, Perry and Berch). A variety of such surfactants are also generally disclosed in U.S. Patent 3,929,678, issued December 30, 1975 to Laughlin, et al. at Column 23, line 58 through Column 29, line 23 (herein incorporated by reference).

25 Other suitable anionic surfactants to be used herein also include acyl sarcosinate or mixtures thereof, in its acid and/or salt form, preferably long chain acyl sarcosinates having the following formula:

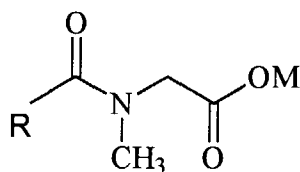

wherein M is hydrogen or a cationic moiety and wherein R is an alkyl group of from 11 to 15 carbon atoms, preferably of from 11 to 13 carbon atoms. Preferred M are hydrogen and alkali metal salts, especially sodium and potassium. Said acyl sarcosinate surfactants are derived from natural fatty acids and the amino-acid sarcosine (N-methyl glycine). They are suitable to be used as aqueous solution of their salt or in their acidic form as powder. Being derivatives of natural fatty acids, said acyl sarcosinates are rapidly and completely biodegradable and have good skin compatibility.

40 Accordingly, particularly preferred long chain acyl sarcosinates to be used herein include C₁₂ acyl sarcosinate (i.e. an acyl sarcosinate according to the above formula wherein M is hydrogen and R is an alkyl group of 11 carbon atoms) and C₁₄ acyl sarcosinate (i.e. an acyl sarcosinate according to the above formula wherein M is hydrogen and R is an alkyl group of 13 carbon atoms). C₁₂ acyl sarcosinate is commercially available, for example, as Hamposyl L-30[®] supplied by Hampshire. C₁₄ acyl sarcosinate is commercially available, for example, as Hamposyl M-30[®] supplied by Hampshire.

50 The liquid aqueous compositions according to the present invention may further comprise other surfactants known to those skilled in the art like an amine oxide surfactant according to the formula R₁R₂R₃NO, wherein each of R₁, R₂ and R₃ is independently a C₁-C₃₀, preferably a C₁-C₂₀, most preferably a C₁-C₁₆ hydrocarbon chain. Amine oxides may be present in amounts up to 10 % by weight of the total composition, more preferably from 1% to 3%.

55 As an optional but highly preferred ingredient, the compositions of the present invention comprise a bleach activator or mixtures thereof. The compositions herein that further comprise a bleach activator or mixtures thereof deliver more effective bleaching performance, especially at ambient temperature at which the pretreatment operation is performed. By "bleach activator", it is meant herein a compound which reacts with hydrogen peroxide to form a peracid. The peracid thus formed constitutes the activated bleach. Particularly suitable bleach activators to be used herein are hydrophobic bleach activators, i.e., a bleach activator which is not substantially and stably miscible with water. Typically, such

hydrophobic bleach activators have a secondary HLB (hydrophilic lipophilic balance) below 11, preferably below 10. Secondary HLB is known to those skilled in the art and is defined for example in "Emulsions theory and practice" by P. Becher, Reinhold, New York, 1957, or in "Emulsion science" by P. Sherman, Academic Press, London, 1969.

5 Suitable bleach activators to be used herein include those belonging to the class of esters, amides, imides, or anhydrides. Examples of suitable compounds of this type are disclosed in British Patent GB 1 586 769 and GB 2 143 231 and a method for their formation into a prilled form is described in European Published Patent Application EP-A-62 523. Suitable examples of such compounds to be used herein are tetracetyl ethylene diamine (TAED), sodium 3,5,5 trimethyl hexanoyloxybenzene sulphonate, diperoxy dodecanoic acid as described for instance in US 4 818 425 and nonylamide of peroxyadipic acid as described for instance in US 4 259 201 and n-nonanoyloxybenzenesulphonate (NOBS). Also
10 suitable are N-acyl caprolactams selected from the group consisting of substituted or unsubstituted benzoyl caprolactam, octanoyl caprolactam, nonanoyl caprolactam, hexanoyl caprolactam, decanoyl caprolactam, undecenoyl caprolactam, formyl caprolactam, acetyl caprolactam, propanoyl caprolactam, butanoyl caprolactam pentanoyl caprolactam or mixtures thereof. A particular family of bleach activators of interest was disclosed in EP 624 154, and particularly preferred in that family is acetyl triethyl citrate (ATC). Acetyl triethyl citrate has the advantage that it is environmental-
15 friendly as it eventually degrades into citric acid and alcohol. Furthermore, acetyl triethyl citrate has a good hydrolytical stability in the product upon storage and it is an efficient bleach activator. Finally, it provides good building capacity to the composition.

The compositions according to the present invention may comprise from 0.01% to 20% by weight of the total composition of said bleach activator, or mixtures thereof, preferably from 1% to 10%, and more preferably from 2% to 7%.

20 The aqueous compositions herein may be formulated as solutions, emulsions or microemulsions depending on the respective ingredients present and respective levels thereof. The compositions according to the present invention that typically comprise a bleach activator, as described hereinbefore, are preferably formulated either as aqueous emulsions of said bleach activator in a matrix comprising water, the peroxygen bleach, the soil suspending agent and an emulsifying surfactant system, or as microemulsions of said bleach activator in a matrix comprising water, the peroxygen
25 bleach, the soil suspending agent and a hydrophilic surfactant system.

Preferred peroxygen bleach-containing emulsions herein comprise an emulsifying surfactant system of at least two different surfactants. Preferred herein, said two different surfactants should have different HLB values (hydrophilic / lipophilic balance) in order to form stable emulsions, and preferably the difference in value of the HLBs of said two surfactants is at least 1, preferably at least 2. Indeed, by appropriately combining at least two of said surfactants with different HLBs in water, emulsions will be formed which do not substantially separate into distinct layers, upon standing
30 for at least two weeks at 40°C.

The emulsions according to the present invention may further comprise other surfactants on top of said emulsifying surfactant system, which should however not significantly alter the weighted average HLB value of the overall emulsion.

In a preferred embodiment of the emulsions of the present invention wherein the emulsions comprise a non-water
35 soluble ingredient to emulsify like a bleach activator as described hereinafter, the emulsifying system meets the equation:

$$\text{HLB}(X) = \frac{\text{weight}\%A}{100} \times \text{HLB}(A) + \frac{\text{weight}\%B}{100} \times \text{HLB}(B) \text{ and } \text{weight}\%A + \text{weight}\%B = 100\%;$$

40 where HLB (X) refers to the HLB of the ingredient to emulsify, if several ingredients are present to emulsify X refers to all of them (weighted average based on % of each ingredient in the formula), HLB (A) refers to the HLB of the hydrophilic surfactant, or mixtures thereof, and HLB (B) refers to the HLB of the hydrophobic surfactant, or mixtures thereof.

In a particularly preferred embodiment of the emulsions of the present invention, wherein the emulsions comprise
45 acetyl triethyl citrate as the bleach activator, an adequate surfactant system, would comprise a hydrophobic nonionic surfactant with for instance an HLB of 6, such as a Dobanol^R 23-2 and a hydrophilic nonionic surfactant with for instance an HLB of 15, such as a Dobanol^R 91-10. Other suitable nonionic surfactant systems comprise for example a Dobanol^R 23-6.5 (HLB about 12) and a Dobanol^R 23 (HLB below 6) or a Dobanol^R 45-7 (HLB=11.6) and a Dobanol 23-3 (HLB=8.1).

50 In the embodiment of the present invention where the compositions are formulated as emulsions said compositions are opaque. In centrifugation examination, it was observed that said emulsions herein showed no phase separation after 15 minutes at 6000 rpm. Under microscopic examination, said emulsions appeared as a dispersion of droplets in a matrix.

In the embodiment of the present invention where the compositions of the present invention are formulated as
55 microemulsions, said bleaching microemulsions according to the present invention comprise a hydrophilic surfactant system comprising at least two different surfactants like a nonionic surfactant and an anionic surfactant. Suitable hydrophilic surfactants to be used herein are those hydrophilic surfactants mentioned herein. In the embodiment wherein the microemulsions herein comprise a peroxygen bleach and a bleach activator, a key factor in order to stably

incorporate the bleach activator in said microemulsions is that at least one of said surfactants of the hydrophilic surfactant system must have a different HLB value to that of the bleach activator. Indeed, if all said surfactants had the same HLB value as that of the activator, a continuous single phase might be formed, thus lowering the chemical stability of the bleach/bleach activator system. Preferably, at least one of said surfactants has an HLB value which differs by at least 1.0 HLB unit, preferably 2.0 to that of said bleach activator.

In the embodiment of the present invention where the compositions are formulated as microemulsions said compositions are macroscopically transparent in the absence of opacifiers and dyes. In centrifugation examination, it was observed that said microemulsions herein showed no phase separation after 15 minutes at 6000 rpm. Under microscopic examination, said microemulsions appeared as a dispersion of droplets in a matrix. We have observed that the particles had a size which is typically around or below 3 micron diameter.

Suitable chelating agents to be used herein include chelating agents selected from the group of phosphonate chelating agents, amino carboxylate chelating agents, polyfunctionally-substituted aromatic chelating agents, and further chelating agents like glycine, salicylic acid, aspartic acid, glutamic acid, malonic acid, or mixtures thereof. Chelating agents when used, are typically present herein in amounts ranging from 0.001% to 5% by weight of the total composition and preferably from 0.05% to 2% by weight.

Suitable phosphonate chelating agents to be used herein may include ethydrionic acid as well as amino phosphonate compounds, including amino alkylene poly (alkylene phosphonate), alkali metal ethane 1-hydroxy diphosphonates, nitrilo trimethylene phosphonates, ethylene diamine tetra methylene phosphonates, and diethylene triamine penta methylene phosphonates. The phosphonate compounds may be present either in their acid form or as salts of different cations on some or all of their acid functionalities. Preferred amino phosphonate chelating agents to be used herein are diethylene triamine penta methylene phosphonate (DTPMP), 1-hydroxy ethane diphosphonate (HEDP) and amino-tri-(methylene phosphonic acid) (ATMP). Such phosphonate chelating agents are commercially available from Monsanto under the trade name DEQUEST®.

Polyfunctionally-substituted aromatic chelating agents may also be useful in the compositions herein. See U.S. patent 3,812,044, issued May 21, 1974, to Connor et al. Preferred compounds of this type in acid form are dihydroxydisulfobenzenes such as 1,2-dihydroxy -3,5-disulfobenzene.

A preferred biodegradable chelating agent for use herein is ethylene diamine N,N'- disuccinic acid, or alkali metal, or alkaline earth, ammonium or substitutes ammonium salts thereof or mixtures thereof. Ethylenediamine N,N'- disuccinic acids, especially the (S,S) isomer have been extensively described in US patent 4, 704, 233, November 3, 1987, to Hartman and Perkins. Ethylenediamine N,N'- disuccinic acids is, for instance, commercially available under the trade-name ssEDDS® from Palmer Research Laboratories.

Suitable amino carboxylates to be used herein include ethylene diamine tetra acetates, diethylene triamine pentaacetates, diethylene triamine pentaacetate (DTPA), N- hydroxyethylethylenediamine triacetates, nitrilotri-acetates, ethylenediamine tetrapropionates, triethylenetetraaminehexa-acetates, ethanol-diglycines, propylene diamine tetracetic acid (PDTA) and methyl glycine di-acetic acid (MGDA), both in their acid form, or in their alkali metal, ammonium, and substituted ammonium salt forms. Particularly suitable amino carboxylates to be used herein are diethylene triamine penta acetic acid, propylene diamine tetracetic acid (PDTA) which is, for instance, commercially available from BASF under the trade name Trilon FS® and methyl glycine di-acetic acid (MGDA).

Another preferred chelating agent for use herein is of the formula:

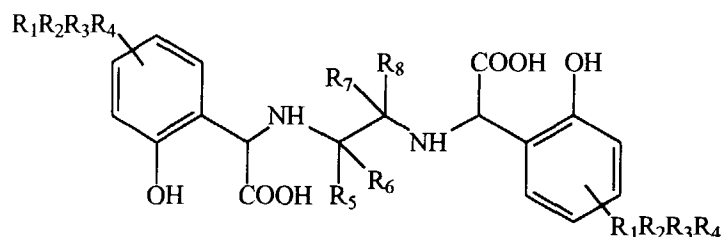

wherein R_1 , R_2 , R_3 , and R_4 are independently selected from the group consisting of -H, alkyl, alkoxy, aryl, aryloxy, -Cl, -Br, -NO₂, -C(O)R', and -SO₂R"; wherein R' is selected from the group consisting of -H, -OH, alkyl, alkoxy, aryl, and aryloxy; R" is selected from the group consisting of alkyl, alkoxy, aryl, and aryloxy; and R_5 , R_6 , R_7 , and R_8 are independently selected from the group consisting of -H and alkyl.

Particularly preferred chelating agents to be used herein are 1-hydroxy ethane diphosphonate (HEDP) and amino-tri-(methylene phosphonic acid) (ATMP), diethylene triamine methylene phosphonate (DTPMP), ethylene N,N'-disuccinic acid, diethylene triamine pentaacetate, glycine, salicylic acid, aspartic acid, glutamic acid, malonic acid or mixtures thereof.

Suitable radical scavengers for use herein include the well-known substituted mono and dihydroxy benzenes and

their analogs, alkyl and aryl carboxylates and mixtures thereof. Preferred such radical scavengers for use herein include di-tert-butyl hydroxy toluene (BHT), hydroquinone, di-tert-butyl hydroquinone, mono-tert-butyl hydroquinone, tert-butyl-hydroxy anisole, benzoic acid, toluic acid, catechol, t-butyl catechol, benzylamine, 1,1,3-tris(2-methyl-4-hydroxy-5-t-butylphenyl) butane, n-propyl-gallate or mixtures thereof and highly preferred is di-tert-butyl hydroxy toluene. Radical scavengers when used, are typically present herein in amounts ranging from 0.001% to 2% by weight of the total composition and preferably from 0.001% to 0.5% by weight.

The presence of chelating agents, and/or radical scavengers allows to contribute to the safety profile of the compositions of the present invention suitable for pretreating a soiled colored fabric upon prolonged contact times before washing said fabric.

The compositions according to the present invention may also comprises a soil suspending polyamine polymer or mixtures thereof. Any soil suspending polyamine polymer known to those skilled in the art may also be used herein. Particularly suitable polyamine polymers for use herein are polyalkoxylated polyamines. Such materials can conveniently be represented as molecules of the empirical structures with repeating units :

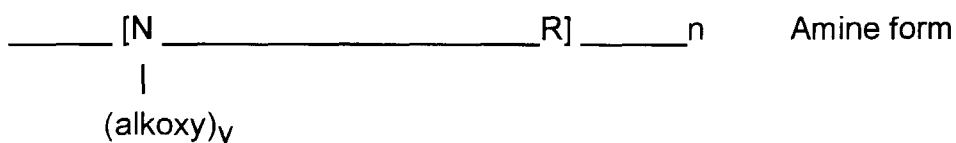

and

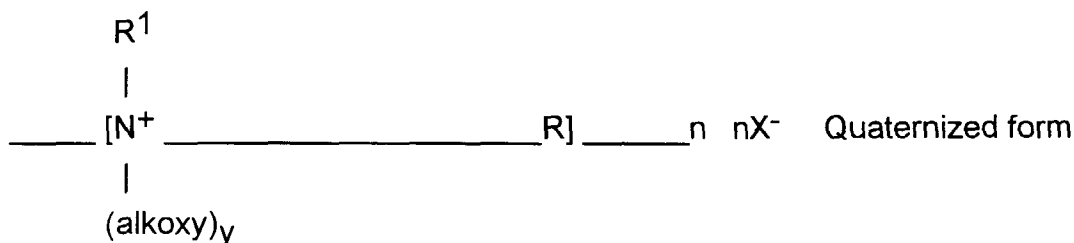

wherein R is a hydrocarbonyl group, usually of 2-6 carbon atoms; R¹ may be a C₁-C₂₀ hydrocarbon; the alkoxy groups are ethoxy, propoxy, and the like, and y is 2-30, most preferably from 10-20; n is an integer of at least 2, preferably from 2-20, most preferably 3-5; and X⁻ is an anion such as halide or methylsulfate, resulting from the quaternization reaction.

The most highly preferred polyamines for use herein are the so-called ethoxylated polyethylene amines, i.e., the polymerized reaction product of ethylene oxide with ethyleneimine, having the general formula :

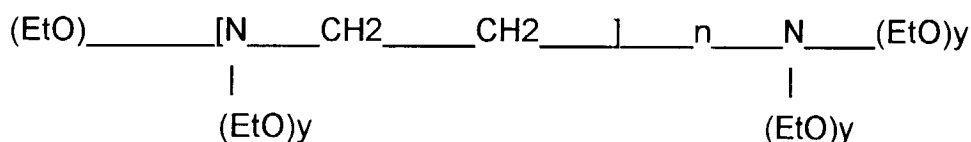

when y = 2-30. Particularly preferred for use herein is an ethoxylated polyethylene amine, in particular ethoxylated tetra-ethylenepentamine, and quaternized ethoxylated hexamethylene diamine.

Typically, the compositions of the present invention comprise from 0.01% to 15% by weight of the total composition of such a soil suspending polyamine polymer or mixtures thereof preferably from 0.1% to 5% and more preferably from 0.2% to 3%.

The compositions of the present invention may further comprise a solvent or mixtures thereof. More particularly, it has been found that the addition of a solvent system comprising at least one hydrophobic solvent and at least one hydrophilic solvent, in a liquid composition according to the present invention, further contributes to the benefits of said composition, i.e., further improves the overall stain removal performance on various type of stains including greasy stains, enzymatic stains as well as bleachable stains. Typically, the liquid aqueous compositions herein may comprise up to 10% from by weight of the total composition of a hydrophobic solvent or mixtures thereof, preferably from 0.1% to 5% and more preferably from 0.2% to 2%, and up to 20% by weight of the total composition of a hydrophilic solvent or mixtures thereof, preferably from 0.5% to 15% and more preferably from 1% to 10%.

Suitable hydrophobic solvents to be used herein include terpenes like mono- and bicyclic monoterpenes, especially those of the hydrocarbon class, which include the terpinenes, terpinolenes, limonenes and pinenes and mixtures thereof. Highly preferred materials of this type are d-limonene, dipentene, alpha-pinene and/or beta-pinene. Other hydrophobic solvents include all type of paraffins, both linear and not, containing from 2 to 20 carbons, preferably from 4 to 10, more preferably from 6 to 8. Preferred herein is octane. Another hydrophobic solvent suitable to be used herein is benzyl alcohol. Particularly preferred hydrophobic solvents to be used herein include d-limonene, dipentene, alpha-pinene, beta-pinene, octane, benzyl alcohol, or mixtures thereof.

Suitable hydrophilic solvents to be used herein include alkoxyated aliphatic alcohols like methoxy propanol, ethoxy propanol, propoxy propanol, butoxy propanol as well as alkoxyated glycols like ethoxy-ethoxy-ethanol, aliphatic alcohols like ethanol, propanol, as well as glycols like propanediol or mixtures thereof.

Any polymeric soil release agent known to those skilled in the art can optionally be employed in the compositions and processes of this invention. Polymeric soil release agents are characterized by having both hydrophilic segments, to hydrophilize the surface of hydrophobic fibres, such as polyester and nylon, and hydrophobic segments, to deposit upon hydrophobic fibres and remain adhered thereto through completion of washing and rinsing cycles and, thus, serve as an anchor for the hydrophilic segments. This can enable stains occurring subsequent to treatment with the soil release agent to be more easily cleaned in later washing procedures.

The polymeric soil release agents useful herein especially include those soil release agents having: (a) one or more nonionic hydrophile components consisting essentially of (i) polyoxyethylene segments with a degree of polymerization of at least 2, or (ii) oxypropylene or polyoxypropylene segments with a degree of polymerization of from 2 to 10, wherein said hydrophile segment does not encompass any oxypropylene unit unless it is bonded to adjacent moieties at each end by ether linkages, or (iii) a mixture of oxyalkylene units comprising oxyethylene and from 1 to about 30 oxypropylene units wherein said mixture contains a sufficient amount of oxyethylene units such that the hydrophile component has hydrophilicity great enough to increase the hydrophilicity of conventional polyester synthetic fiber surfaces upon deposit of the soil release agent on such surface, said hydrophile segments preferably comprising at least about 25% oxyethylene units and more preferably, especially for such components having about 20 to 30 oxypropylene units, at least about 50% oxyethylene units; or (b) one or more hydrophobe components comprising (i) C₃ oxyalkylene terephthalate segments, wherein, if said hydrophobe components also comprise oxyethylene terephthalate, the ratio of oxyethylene terephthalate:C₃ oxyalkylene terephthalate units is about 2:1 or lower, (ii) C₄-C₆ alkylene or oxy C₄-C₆ alkylene segments, or mixtures therein, (iii) poly (vinyl ester) segments, preferably polyvinyl acetate, having a degree of polymerization of at least 2, or (iv) C₁-C₄ alkyl ether or C₄ hydroxyalkyl ether substituents, or mixtures therein, wherein said substituents are present in the form of C₁-C₄ alkyl ether or C₄ hydroxyalkyl ether cellulose derivatives, or mixtures therein, and such cellulose derivatives are amphiphilic, whereby they have a sufficient level of C₁-C₄ alkyl ether and/or C₄ hydroxyalkyl ether units to deposit upon conventional polyester synthetic fiber surfaces and retain a sufficient level of hydroxyls, once adhered to such conventional synthetic fiber surface, to increase fiber surface hydrophilicity, or a combination of (a) and (b).

Typically, the polyoxyethylene segments of (a)(i) will have a degree of polymerization of from about 1 to about 200, although higher levels can be used, preferably from 3 to about 150, more preferably from 6 to about 100. Suitable oxy C₄-C₆ alkylene hydrophobe segments include, but are not limited to, end-caps of polymeric soil release agents such as MO₃S(CH₂)_nOCH₂CH₂O⁻, where M is sodium and n is an integer from 4-6, as disclosed in U.S. Patent 4,721,580, issued January 26, 1988 to Gosselink.

Polymeric soil release agents useful in the present invention also include cellulosic derivatives such as hydroxyether cellulosic polymers, copolymeric blocks of ethylene terephthalate or propylene terephthalate with polyethylene oxide or polypropylene oxide terephthalate, and the like. Such agents are commercially available and include hydroxyethers of cellulose such as METHOCEL (Dow). Cellulosic soil release agents for use herein also include those selected from the group consisting of C₁-C₄ alkyl and C₄ hydroxyalkyl cellulose; see U.S. Patent 4,000,093, issued December 28, 1976 to Nicol, et al.

Soil release agents characterized by poly(vinyl ester) hydrophobe segments include graft copolymers of poly(vinyl ester), e.g., C₁-C₆ vinyl esters, preferably poly(vinyl acetate) grafted onto polyalkylene oxide backbones, such as polyethylene oxide backbones. See European Patent Application 0 219 048, published April 22, 1987 by Kud, et al. Commercially available soil release agents of this kind include the SOKALAN type of material, e.g., SOKALAN HP-22, available from BASF (West Germany).

One type of preferred soil release agent is a copolymer having random blocks of ethylene terephthalate and polyethylene oxide (PEO) terephthalate. The molecular weight of this polymeric soil release agent is in the range of from about 25,000 to about 55,000. See U.S. Patent 3,959,230 to Hays, issued May 25, 1976 and U.S. Patent 3,893,929 to Basadur issued July 8, 1975.

Another preferred polymeric soil release agent is a polyester with repeat units of ethylene terephthalate units which contains 10-15% by weight of ethylene terephthalate units together with 90-80% by weight of polyoxyethylene terephthalate units, derived from a polyoxyethylene glycol of average molecular weight 300-5,000. Examples of this polymer

ferred for use herein. Preferably the PVPVI has an average molecular weight range from 5,000 to 1,000,000, more preferably from 5,000 to 200,000, and most preferably from 10,000 to 20,000. (The average molecular weight range is determined by light scattering as described in Barth, et al., Chemical Analysis, Vol 113. "Modern Methods of Polymer Characterization", the disclosures of which are incorporated herein by reference.) The PVPVI copolymers typically have a molar ratio of N-vinylimidazole to N-vinylpyrrolidone from 1:1 to 0.2:1, more preferably from 0.8:1 to 0.3:1, most preferably from 0.6:1 to 0.4:1. These copolymers can be either linear or branched.

The present invention compositions may also employ a polyvinylpyrrolidone ("PVP") having an average molecular weight of from about 5,000 to about 400,000, preferably from about 5,000 to about 200,000, and more preferably from about 5,000 to about 50,000. PVP's are known to persons skilled in the detergent field; see, for example, EP-A-262,897 and EP-A-256,696, incorporated herein by reference. Compositions containing PVP can also contain polyethylene glycol ("PEG") having an average molecular weight from about 500 to about 100,000, preferably from about 1,000 to about 10,000. Preferably, the ratio of PEG to PVP on a ppm basis delivered in wash solutions is from about 2:1 to about 50:1, and more preferably from about 3:1 to about 10:1.

If high sudsing is desired, suds boosters such as C₁₀-C₁₆ alkanolamides can be incorporated into the compositions, typically at 1%-10% levels. The C₁₀-C₁₄ monoethanol and diethanol amides illustrate a typical class of such suds boosters. Use of such suds boosters with high sudsing adjunct surfactants such as the amine oxides, betaines and sultaines noted above is also advantageous. If desired, soluble magnesium salts such as MgCl₂, MgSO₄, and the like, can be added at levels of, for example, 0.1%-2%, to provide additional suds and to enhance grease removal performance.

Any optical brighteners, fluorescent whitening agents or other brightening or whitening agents known in the art can be incorporated in the instant compositions when they are designed for fabric treatment or laundering, at levels typically from about 0.05% to about 1.2%, by weight, of the detergent compositions herein. Commercial optical brighteners which may be useful in the present invention can be classified into subgroups, which include, but are not necessarily limited to, derivatives of stilbene, pyrazoline, coumarin, carboxylic acids, methinecyanines, dibenzothiophene-5,5-dioxide, azoles, 5- and 6-membered-ring heterocyclic brighteners, this list being illustrative and non-limiting. Examples of such brighteners are disclosed in "The Production and Application of Fluorescent Brightening Agents", M. Zahradnik, Published by John Wiley & Sons, New York (1982).

Specific examples of optical brighteners which are useful in the present compositions are those identified in U.S. Patent 4,790,856, issued to Wixon on December 13, 1988. These brighteners include the PHORWHITE series of brighteners from Verona. Other brighteners disclosed in this reference include: Tinopal UNPA, Tinopal CBS and Tinopal 5BM; available from Ciba-Geigy; Artic White CC and Artic White CWD, available from Hilton-Davis, located in Italy; the 2-(4-styryl-phenyl)-2H-naphthol[1,2-d]triazoles; 4,4'-bis-(1,2,3-triazol-2-yl)stilbenes; 4,4'-bis(styryl)bisphenyls; and the aminocoumarins. Specific examples of these brighteners include 4-methyl-7-diethyl-amino coumarin; 1,2-bis(-benzimidazol-2-yl)ethylene; 2,5-bis(benzoxazol-2-yl)thiophene; 2-styrylnaph-[1,2-d]oxazole; and 2-(stilbene-4-yl)-2H-naphtho-[1,2-d]triazole. See also U.S. Patent 3,646,015, issued February 29, 1972 to Hamilton. Anionic brighteners are typically preferred herein.

The compositions of the present invention suitable for pretreating fabrics can be packaged in a variety of containers including conventional bottles, bottles equipped with roll-on, sponge, brusher or sprayers. Also as the aqueous compositions herein are chemically stable, they may be packaged in a given deformable container/bottle without compromising the stability of said container/bottle comprising it upon standing, for long periods of time.

Stain removal performance/bleaching performance test method

The stain removal and/or bleaching performance of a given composition on a soiled fabric under pretreatment conditions, may be evaluated by the following test method. An aqueous composition according to the present invention is first applied to the stained portion of said fabric, left to act from about 1 to about 10 minutes, typically 5 minutes, and said pretreated fabric is then washed according to common washing conditions with a conventional detergent composition, at a temperature of from 30°C to 70°C for a period of time sufficient to bleach said fabric. For example, typical soiled fabrics to be used in this test method may be commercially available from EMC (Empirical Manufacturing Company) Cincinnati, Ohio, USA such as clay, chocolate, spaghetti sauce, dirty motor oil, make-up, tea, coffee, blood on two different substrate/fabric, e.g., cotton (CW120) and polycotton (PCW28). The stain removal/bleaching performance may then be evaluated by comparing side by side the soiled fabric pretreated with the composition according to the present invention with those pretreated with the reference, e.g., the same composition without such a soil suspending agent according to the present invention. A visual grading scale may be used to assign differences in panel score units (psu), in a range from 0 to 4.

The present invention will be further illustrated by the following examples.

Examples

The following compositions were made by mixing the listed ingredients in the listed proportions (weight % unless otherwise specified).

5

10

15

20

25

30

35

Compositions	I	II	III	IV	V	VI	VII	VIII
Dobanol® 45-7	6.4	6.4	6.4	1.5	12.0	6.0	-	1.5
Dobanol® 23-3	8.6	8.6	8.6	-	-	6.0	1.5	1.5
Dobanol® 23-6.5	-	-	-	1.5	-	-	-	-
Dobanol® 91-10	-	-	-	-	-	-	1.5	-
C25-AE-2.5-S	4.0	4.0	4.0	1.5	12.0	6.0	-	-
C10 Alkyl Sulphate	-	-	-	-	-	-	1.7	1.7
Alkyl glucose amide	2.0	2.0	2.0	-	-	-	-	-
ATC*	3.5	3.5	3.5	-	3.5	-	-	-
H ₂ O ₂	4.0	4.0	4.0	-	6.0	4.0	7.0	7.0
Dilauroyl peroxide	0.5	-	-	1.0	-	2.0	-	-
EHDQ**	0.5	0.5	0.5	0.2	1.0	0.7	0.5	0.5
Limonene D(+)	-	-	0.5	0.1	0.5	1.0	-	-
Benzoyl alcohol	-	-	2.0	1.0	-	-	-	-
1-methoxy-2 propanol	-	-	5.0	-	2.0	3.0	-	-
ATMP***	0.2	0.1	-	-	0.16	-	-	-
HEDP****	-	-	-	-	-	-	-	0.16
DTPMP*****	-	-	-	-	-	-	0.18	-
Water and minors	-----up to 100%-----							
H ₂ SO ₄ up to pH 4								

ATC* is acetyl triethyl citrate.

Dobanol ® 23-3 is a C12-C13 nonionic ethoxylated surfactant with HLB of 8.1.

40

Dobanol ® 23-6.5 is a C12-C13 nonionic ethoxylated surfactant with HLB of 11.9.

Dobanol ® 45-7 is a C14-C15 nonionic ethoxylated surfactant with HLB of 11.6.

Dobanol ® 91-10 is a C9-C11 nonionic ethoxylated surfactant with HLB of 14.7.

45

ATMP*** is aminotri(methylene phosphonic acid).

DTPMP***** is diethylene triamine penta methylene phosphonate.

HEDP**** is 1-Hydroxy Ethane Diphosponate.

50

55

EHDQ*** is 24-Ethoxylated Hexamethylene Diamine Quaternized methyl chloride

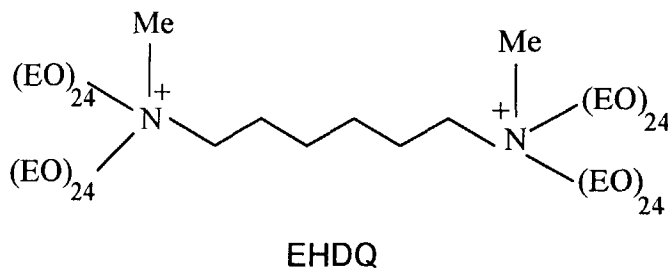

15

Excellent stain removal performance is obtained on a variety of stains including greasy/oily stains like clay, dirty motor oil, make-up, lipstick, carotenoid-type stains like spaghetti sauce, bleachable stains like tea and enzymatic stains like grass, blood, when pretreating soiled fabrics with any of the compositions I to VIII, as described above, e.g., when leaving such a composition to act onto the fabrics for a contact period of about 5 minutes, before rinsing said fabrics with water or washing according to standard US or European washing conditions.

Claims

- 25 1. A liquid aqueous composition suitable for pretreating fabrics, having a pH below 6, and comprising a peroxygen bleach and a soil suspending agent selected from the group consisting of:

1) ethoxylated cationic diamines having the formula:

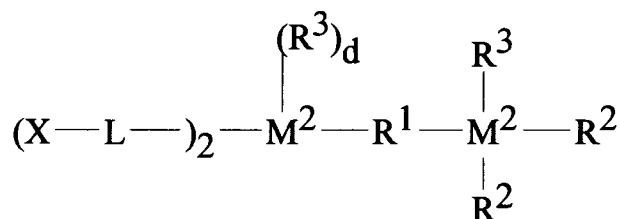
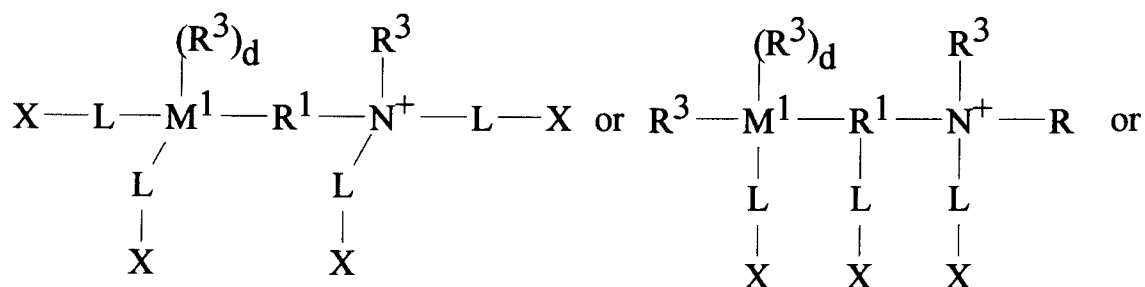

50 wherein M¹ is an N⁺ or N group; each M² is an N⁺ or N group, and at least one M² is an N⁺ group;

2) ethoxylated cationic polyamines having the formula:

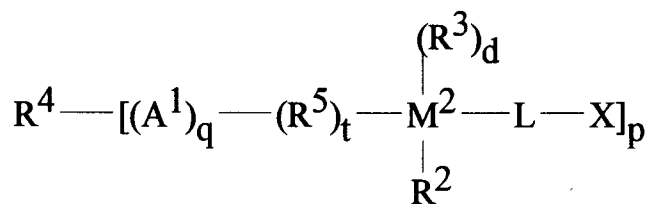

3) ethoxylated cationic polymers which comprises a polymer backbone, at least 2M groups and at least one L-X group, wherein M is a cationic group attached to or integral with the backbone; X is a nonionic group selected from the group consisting of H, C₁-C₄ alkyl or hydroxyalkyl ester or ether groups, and mixtures thereof; and L is a hydrophilic chain connecting groups M and X or connecting X to the polymer backbone,
4) mixtures thereof; wherein A¹ is

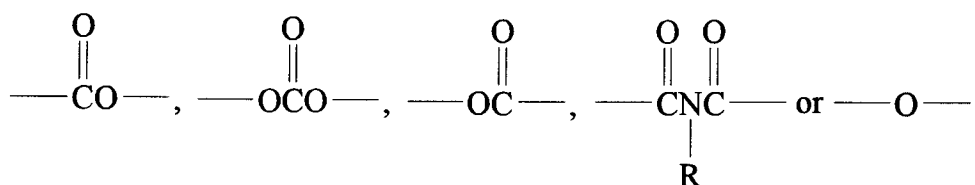
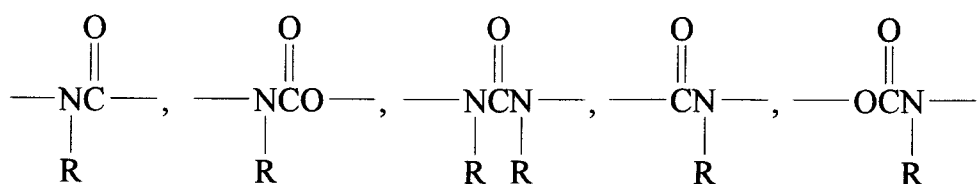

R is H or C₁-C₄ alkyl or hydroxyalkyl, R¹ is C₂-C₁₂ alkylene, hydroxyalkylene, alkenylene, arylylene or alkarylylene, or a C₂-C₃ oxyalkylene moiety having from 2 to about 20 oxyalkylene units provided that no O-N bonds are formed; each R² is C₁-C₄ alkyl or hydroxyalkyl, the moiety -L-X, or two R² together form the moiety -(CH₂)_r-A²-(CH₂)_s-, wherein A² is -O- or -CH₂-, r is 1 or 2, s is 1 or 2 and r + s is 3 or 4; each R³ is C₁-C₈ alkyl or hydroxyalkyl, benzyl, the moiety L-X, or two R³ or one R² and one R³ together form the moiety -(CH₂)_r-A²-(CH₂)_s-; R⁴ is a substituted C₃-C₁₂ alkyl, hydroxyalkyl, alkenyl, aryl or alkaryl group having p substitution sites; R⁵ is C₁-C₁₂ alkenyl, hydroxyalkylene, alkenylene, arylylene or alkarylylene, or a C₂-C₃ oxyalkylene moiety having from 2 to about 20 oxyalkylene units provided that no O-O or O-N bonds are formed; X is a nonionic group selected from the group consisting of H, C₁-C₄ alkyl or hydroxyalkyl ester or ether groups, and mixtures thereof; L is a hydrophilic chain which contains the polyoxyalkylene moiety -[(R⁶O)_m(CH₂CH₂O)_n]-; wherein R⁶ is C₃-C₄ alkylene or hydroxyalkylene and m and n are numbers such that the moiety -(CH₂CH₂O)_n- comprises at least about 50% by weight of said polyoxyalkylene moiety; d is 1 when M² is N⁺ and is 0 when M² is N; n is at least about 6 for said cationic diamines and is at least 3 for said cationic polyamines and cationic polymers; p is from 3 to 8; q is 1 or 0; t is 1 or 0, provided that t is 1 when q is 1.

2. A composition according to claim 1, wherein said peroxygen bleach is hydrogen peroxide or a water-soluble source thereof preferably selected from the group consisting of percarbonate, persulfate, persulfate, perborate, peroxyacids, hydroperoxides, diacyl peroxides and mixtures thereof and more preferably is hydrogen peroxide, tert-butyl hydroperoxide, cumyl hydroperoxide, 2,4,4-trimethylpentyl-2-hydroperoxide, di-isopropylbenzene-monohydroperoxide, tert-amyl hydroperoxide, 2,5-dimethyl-hexane-2,5-dihydroperoxide, dilauroyl peroxide, didecanoyl peroxide, dimyristoyl peroxide, or mixtures thereof.

3. A composition according to any of the preceding claims which comprises from 0.01% to 15% by weight of the total composition of said peroxygen bleach, or mixtures thereof, preferably from 0.1% to 12%, more preferably from

0.5% to 10% and most preferably from 2% to 8%.

4. A composition according to any of the preceding claims 1 to 3 wherein said soil suspending agent is an ethoxylated cationic diamine wherein R¹ is a C₂-C₆ alkylene, preferably hexamethylene.
5. A composition according to any of the preceding claims 1 to 3 wherein said soil suspending agent is an ethoxylated cationic polyamine, wherein R₄ is a substituted C₃-C₆ alkyl, hydroxyalkyl or aryl group; A₁ is

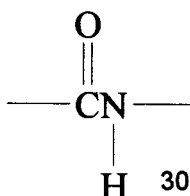

and p is from 3 to 6.

6. A composition according to any of the preceding claims 1 to 3 wherein said soil suspending agent is an ethoxylated cationic amine polymer which has a backbone selected from the group consisting of the polyurethanes, the polyesters, the polyethers, the polyamides, the polyimides, the polyacrylates, the polyacrylamides, the polyvinylethers, the polyalkylenes, the polystyrenes, the polyalkarylenes, the polyalkyleneamines, the polyalkyleneimines, the polyvinylamines, the polyallylamines, the polydiallylamines, the polyvinylpyridines, the polyaminotriazoles, polyvinyl alcohol, the aminopolyureylenes, and mixtures thereof.
7. A composition according to any of the preceding claims which comprises from 0.01% to 10% by weight of the total composition of said soil suspending agent, or mixtures thereof, preferably from 0.05% to 5%, more preferably from 0.1% to 4%, and most preferably from 0.2% to 2%.
8. A composition according to any of the preceding claims which further comprises a bleach activator, preferably at a level of from 0.01% to 20% by weight of the total composition, more preferably from 1% to 10% and most preferably from 2% to 7%.
9. A composition according to claim 8 wherein said bleach activator is selected from the group consisting of acetyl triethyl citrate, tetracetyl ethylene diamine, sodium 3,5,5 trimethyl hexanoyloxybenzene sulphonate, diperoxy dodecanoic acid, nonylamide of peroxyadipic acid, n-nonanoyloxybenzenesulphonate, N-acyl caprolactam, substituted and unsubstituted benzoyl caprolactam, octanoyl caprolactam, nonanoyl caprolactam, hexanoyl caprolactam, decanoyl caprolactam, undecenoyl caprolactam, formyl caprolactam, acetyl caprolactam, propanoyl caprolactam, butanoyl caprolactam, pentanoyl caprolactam and mixtures thereof, and preferably is acetyl triethyl citrate.
10. A composition according to any of the preceding claims, which has a pH below 5, more preferably from 1 to 4.5, and most preferably from 2 to 4.5.
11. A composition according to any of the preceding claims which further comprises at least an optional ingredient selected from the group consisting of surfactants, stabilisers, chelating agents, radical scavengers, builders, soil suspenders, dye transfer agents, solvents, brighteners, perfumes, foam suppressors, dyes and mixtures thereof.
12. A composition according to any of the preceding claims which is in the form of an emulsion or microemulsion.
13. A process of bleaching a soiled fabric with a liquid acidic aqueous composition according to any of the preceding claims, said process comprising the steps of applying said composition in its neat form onto at least a portion of said fabric, before said fabric is washed.
14. A process according to claim 13 wherein said composition is allowed to remain in contact with said fabric from 1 minute to 1 hour, preferably from 1 minute to 30 minutes and more preferably from 2 minutes to 10 minutes, before said fabric is washed.



European Patent
Office

EUROPEAN SEARCH REPORT

Application Number
EP 96 87 0137

DOCUMENTS CONSIDERED TO BE RELEVANT			
Category	Citation of document with indication, where appropriate, of relevant passages	Relevant to claim	CLASSIFICATION OF THE APPLICATION (Int.Cl.6)
D,A	EP 0 111 965 A (PROCTER & GAMBLE) 27 June 1984 * page 50, line 6 - line 16; claims * ---	1,4-7	C11D3/39 C11D3/37
A	WO 96 26999 A (PROCTER & GAMBLE) 6 September 1996 * claims; examples * ---	1-3,13	
A	US 4 561 991 A (HERBOTS IVAN ET AL) 31 December 1985 * column 5, line 16 - line 25; claims * ---	1,6,11, 12	
A	PATENT ABSTRACTS OF JAPAN vol. 096, no. 004, 30 April 1996 & JP 07 331289 A (KAO CORP), 19 December 1995, * abstract * -----	1-3	
			TECHNICAL FIELDS SEARCHED (Int.Cl.6)
			C11D
The present search report has been drawn up for all claims			
Place of search		Date of completion of the search	Examiner
THE HAGUE		1 April 1997	Grittern, A
CATEGORY OF CITED DOCUMENTS			
X : particularly relevant if taken alone		T : theory or principle underlying the invention	
Y : particularly relevant if combined with another document of the same category		E : earlier patent document, but published on, or after the filing date	
A : technological background		D : document cited in the application	
O : non-written disclosure		L : document cited for other reasons	
P : intermediate document		& : member of the same patent family, corresponding document	

EPO FORM 1503 03.82 (P04C01)