

(19)



Europäisches Patentamt

European Patent Office

Office européen des brevets



(11)

EP 0 839 969 A1

(12)

EUROPEAN PATENT APPLICATION

(43) Date of publication:
06.05.1998 Bulletin 1998/19

(51) Int. Cl.⁶: E04B 1/94

(21) Application number: 96830547.4

(22) Date of filing: 29.10.1996

(84) Designated Contracting States:
**AT BE CH DE DK ES FI FR GB GR IE IT LI LU MC
NL PT SE**
Designated Extension States:
AL LT LV RO SI

(72) Inventor: **Migliavacca, Pietro**
24121 Bergamo (IT)

(74) Representative:
Modiano, Guido, Dr.-Ing. et al
Modiano & Associati S.r.l.
Via Meravigli, 16
20123 Milano (IT)

(71) Applicant: **Migliavacca, Pietro**
24121 Bergamo (IT)

(54) Barrier for passive protection against the spread of flames or heat

(57) A barrier for passive protection against the spread of flames or heat, comprising a casing internally forming at least one compartment (4) sealed with respect to the outside environment and containing an intumescent substance (1). The substance (1) can be released externally in the presence of flames or heat that break the casing.

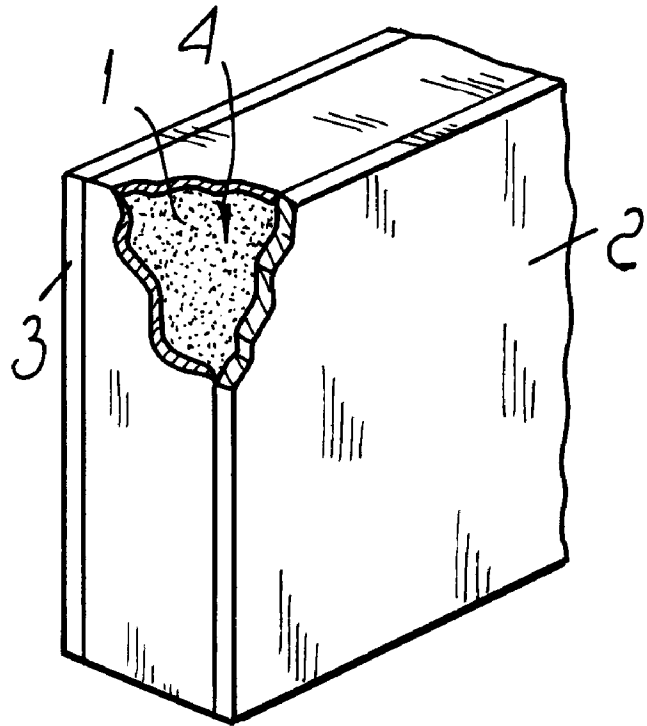

Fig. 1

EP 0 839 969 A1

Description

The present invention relates to a barrier for passive protection against the spread of flames or heat.

Barriers for passive protection against the spread of flames or heat for use in the field of civil or industrial building are known.

Currently in use protective barriers are generally constituted by panels or coverings based on mineral fibers, or based on cement compounds, or paints based on intumescent substances which are applied to the surfaces of the objects or structures to be protected.

These barriers have the effect of halting, or at least slowing, the spread of flames in case of fire but do not solve some problems that significantly limit their use.

In particular, these barriers, due to the use of organic solvents and powders and mineral fibers, entail environmental pollution problems both during application and later. In order to limit this phenomenon, particular precautions are necessary during production and it is very often necessary to use special shielding to avoid the loss of noxious substances, such as dust or fibers, into the environment.

Another problem that can be observed with the use of barriers containing organic substances is the emission of opaque fumes or toxic gases when they make contact with fire or as a consequence of high temperatures. This problem is felt particularly strongly, since the fumes or toxic gases, in addition to producing environmental pollution, can endanger and slow the action of operators assigned to extinguishing the fire.

A further problem of these barriers is constituted by their low resistance to atmospheric and environmental factors, particularly humidity, which reduce their effectiveness over time by degrading their properties and/or composition.

A principal aim of the present invention is to solve the above problems by providing a barrier for passive protection against the spread of flames or heat that offers adequate assurances of safety against the emission of noxious or polluting substances both during and after application.

Within the scope of this aim, an object of the present invention is to provide a barrier that does not produce emissions of gases, vapors, or noxious fumes when it makes contact with flames or is exposed to high temperatures.

Another object of the invention is to provide a barrier that offers adequate assurances of resistance to environmental or atmospheric factors, particularly humidity, maintaining its effectiveness unchanged over time.

Another object of the present invention is to provide a barrier that is highly versatile in use so that it can be used for various applications.

This aim, these objects, and others that will become apparent hereinafter are achieved by a barrier for passive protection against the spread of flames or heat,

characterized in that it comprises a casing internally forming at least one compartment sealed with respect to the outside environment and containing an intumescent substance that can be released externally in the presence of flames or heat that break said casing.

Further characteristics and advantages of the invention will become apparent from the following detailed description of some preferred but not exclusive embodiments of the barrier according to the invention, illustrated only by way of non-limitative example in the accompanying drawings, wherein:

figure 1 is a cutout perspective view of a first embodiment of the barrier according to the invention;

figure 2 is a perspective view of a second embodiment of the barrier according to the invention;

figure 3 is a sectional view of figure 2, taken along the plane III-III;

figure 4 is a view of a possible different embodiment of the barrier in the second embodiment;

figure 5 is a sectional view of a third embodiment of the barrier according to the invention;

figure 6 is a cutout perspective view of a fourth embodiment of the barrier according to the invention; and

figure 7 is a partially cutout perspective view of a fifth embodiment of the barrier according to the invention.

With reference to the above figures, the barrier according to the invention substantially comprises a casing that internally forms at least one compartment that is sealed with respect to the outside environment and contains an intumescent substance that is released externally in the presence of flames or heat that break the casing in which the intumescent substance it contained.

More particularly, the casing that contains the intumescent substance can be simply constituted by a structure, such as for example a panel, in which an interspace is provided that is sealed with respect to the outside environment and contains the intumescent substance.

As shown in figure 1, the casing that contains the intumescent substance 1 can be constituted simply by a panel composed of two sheets 2 and 3 facing each other and mutually spaced. The two sheets 2 and 3 are sealed peripherally, so that the compartment 4, which is formed between the two sheets 2 and 3 and contains the intumescent substance 1, is sealed with respect to the outside environment.

The sheets 2 and 3 can be made of metallic material, for example aluminum, or glass, or synthetic material, preferably a waterproof material.

The casing that contains the intumescent substance can also be constituted, as shown in figures 2 and 3, by a sheet of synthetic material with a plurality of

blisters, in which the intumescent substance 1 is placed inside the various blisters.

In practice, the blisters are formed by a layer of synthetic material 5 that is deformed so as to have hollow recesses 6 that are directed towards another layer of synthetic material 7 that faces the layer 5 and is sealed against it, so as to hermetically close the hollow recesses 6, which are filled with the intumescent substance 1 beforehand.

As shown in figure 4, the sheet of multiple-blister synthetic material can be constituted by three layers of synthetic material instead of two: respectively, two flat layers 8 and 9 that face each other and a third layer 10 that is interposed between them and in which the hollow recesses 11 containing the intumescent substance 1 are formed.

The casing that contains the intumescent substance 1 can also be made of appropriately waterproofed paper-like material.

In a preferred embodiment, shown in figure 5, the casing can be constituted by corrugated cardboard with at least one substantially flat layer 12, on one face whereof a corrugated layer 13 is applied so that cells 14 are formed between the layer 12 and the layer 13; the intumescent substance 1 is introduced in said cells.

In this case, too, instead of a single flat layer 12, it is possible to provide for two mutually facing flat layers 12 and 15 between which the corrugated layer 13 is arranged, so as to have twice as many cells 14 that are respectively delimited by the layer 12, by the corrugated layer 13, and by the layer 15 and in which the intumescent substance 1 is introduced.

As shown in figure 6, the casing that contains the intumescent substance can also be constituted by two sheets 16 and 17 facing each other and between which an additional honeycomb structure 18 is interposed, forming a plurality of cells inside which the intumescent substance 1 is introduced.

In this case, the various cells are delimited, hermetically with respect to the outside environment, by the sheets 16 and 17 and by the additional structure 18.

The material of which the sheets 16 and 17 and the additional structure 18 are made can be constituted by metallic material, synthetic material, or paper-like material, or by glass, exclusively for the sheets 16 and 17, according to the requirements.

As shown in figure 7, the casing that contains the intumescent substance 1 can also be simply constituted by a macrocapsule 19 that can have various configurations according to the requirements and is preferably made of synthetic material.

The dimensions of the macrocapsule 19 can vary according to the type of use for which it is meant. In particular, the macrocapsules 19 can be used as filler for interspaces formed inside structures such as panels or the like, or directly inside interspaces formed in the walls of buildings to be protected.

The intumescent substance 1 is conveniently of an

inorganic type and is preferably constituted by a silicate or by a mixture of alkaline silicates.

The intumescent substance 1 can be introduced in the casing of the barrier according to the invention in powder form, in liquid form, or in pasty or gel form, according to the requirements.

The operation of the barrier according to the invention is as follows.

When the barrier according to the invention makes contact with flames, or is simply raised to a temperature above 100°C, it forms a foam or porous expanding mass that is highly insulating and refractory and can reach a final volume that is approximately 10-15 times the original one. The intumescent substance, by expanding, breaks the casing in which it is contained and leaks out, forming a compact layer of rigid and insulating foam on the entire surface of the barrier.

It should be noted that the intumescent substance contained in the barrier according to the invention does not emit toxic gases or fumes even if it makes direct contact with the flame.

It should also be noted that the casing that contains the intumescent substance 1 can be made of deformable material, so as to allow to apply the barrier in close contact with various kinds of items, such as piping or electric wires, for which protection against flames or high temperatures is desired.

In practice it has been observed that the barrier according to the invention fully achieves the intended aim, since it ensures excellent resistance to flames and heat without causing polluting or noxious emissions.

Another advantage of the barrier according to the invention is that in the absence of flames or high temperatures it prevents the contact of the intumescent substance with external factors, particularly humidity, protecting the effectiveness of the intumescent substance over time.

The barrier thus conceived is susceptible of numerous modifications and variations, all of which are within the scope of the inventive concept; all the details may furthermore be replaced with other technically equivalent elements.

Where technical features mentioned in any claim are followed by reference signs, those reference signs have been included for the sole purpose of increasing the intelligibility of the claims and accordingly, such reference signs do not have any limiting effect on the interpretation of each element identified by way of example by such reference signs.

Claims

1. A barrier for passive protection against the spread of flames or heat, characterized in that it comprises a casing internally forming at least one compartment sealed with respect to the outside environment and containing an intumescent substance that can be released externally in the presence of

- flames or heat that break said casing.
2. A barrier according to claim 1, characterized in that said intumescent substance is of the inorganic type. 5
 3. A barrier according to claim 1, characterized in that said intumescent substance is constituted by a silicate.
 4. A barrier according to claim 1, characterized in that said intumescent substance is constituted by a mixture of alkaline silicates. 10
 5. A barrier according to claim 1, characterized in that said intumescent substance is in powder form. 15
 6. A barrier according to claim 1, characterized in that said intumescent substance is in liquid form.
 7. A barrier according to claim 1, characterized in that said intumescent substance is in pasty or gel form. 20
 8. A barrier according to claim 1, characterized in that said casing is made of waterproof material. 25
 9. A barrier according to claim 1, characterized in that said casing is made of metallic material.
 10. A barrier according to claim 1, characterized in that said casing is made of glass. 30
 11. A barrier according to claim 1, characterized in that said casing is made of synthetic material.
 12. A barrier according to claim 1, characterized in that said casing is made of paper-like material. 35
 13. A barrier according to claim 1, characterized in that said casing is made of waterproofed paper-like material. 40
 14. A barrier according to claim 1, characterized in that said casing is constituted by two mutually spaced and facing sheets that are peripherally sealed to each other so as to delimit said compartment hermetically. 45
 15. A barrier according to claim 1, characterized in that said compartment is divided into a plurality of cells that are at least partially filled with said intumescent substance. 50
 16. A barrier according to claim 15, characterized in that said cells are formed by one of said sheets and by deformed portions of the other sheet. 55
 17. A barrier according to claim 16, characterized in that said deformed portions are constituted by hollow recesses formed on at least one of said two sheets.
 18. A barrier according to claim 16, characterized in that said deformed portions are constituted by corrugations of one of said two sheets.
 19. A barrier according to claim 16, characterized in that said cells are formed by a structure that is interposed between said two sheets.
 20. A barrier according to claim 15, characterized in that said structure is constituted by a honeycomb structure.
 21. A barrier according to claim 15, characterized in that said structure is constituted by a corrugated sheet interposed between said two sheets.
 22. A barrier according to claim 1, characterized in that said casing is constituted by a macrocapsule.
 23. A barrier according to claim 1, characterized in that said casing is constituted by a multiple-blister sheet made of synthetic material, in which the blisters contain said intumescent substance.

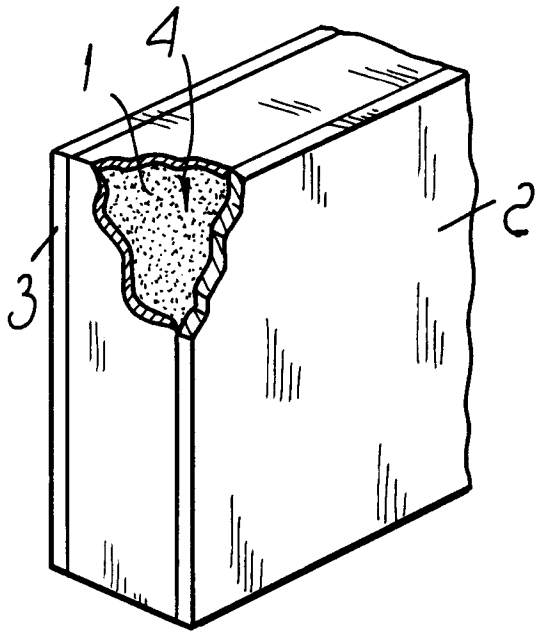

FIG. 1

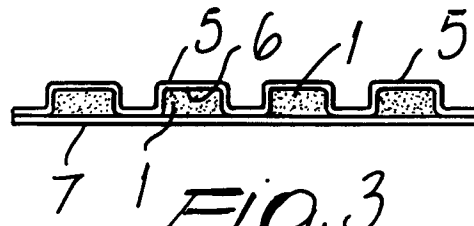

FIG. 3

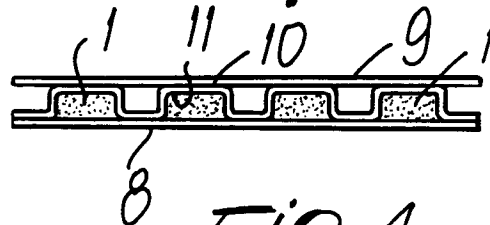

FIG. 4

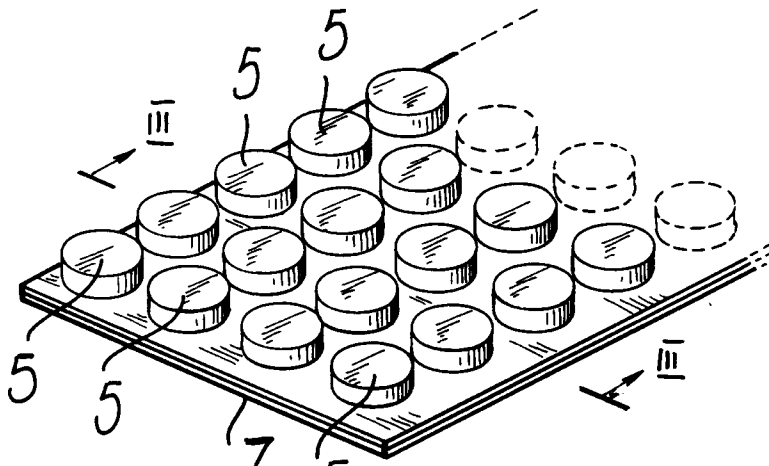

FIG. 2

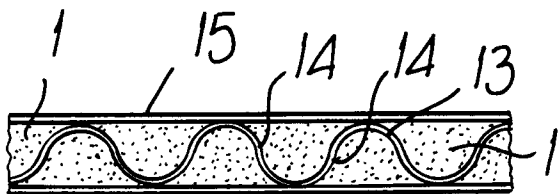

FIG. 5

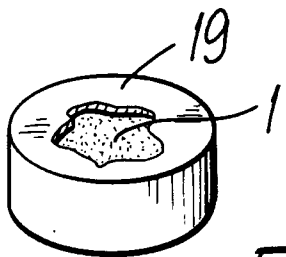

FIG. 7

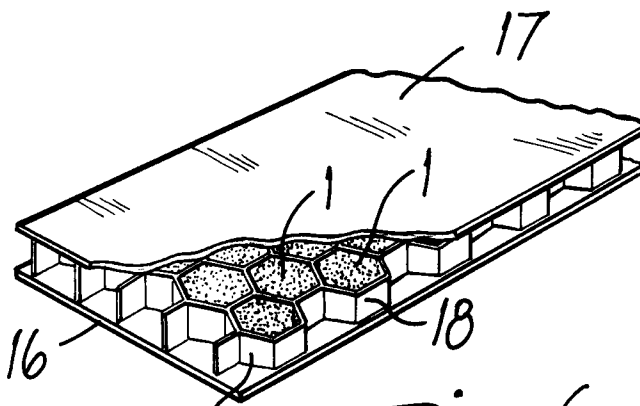

FIG. 6



European Patent
Office

EUROPEAN SEARCH REPORT

Application Number
EP 96 83 0547

DOCUMENTS CONSIDERED TO BE RELEVANT				
Category	Citation of document with indication, where appropriate, of relevant passages	Relevant to claim	CLASSIFICATION OF THE APPLICATION (Int.Cl.6)	
X Y	GB 2 070 114 A (TYNETOWER LTD) * the whole document * ---	1-3,8,11 4	E04B1/94	
X Y A	DE 31 25 577 A (BONIN) * the whole document * ---	1-3,5,8, 9,11-13, 15-19,21 20 14		
X	DATABASE WPI Week 9314 30 April 1992 Derwent Publications Ltd., London, GB; AN 93115519 XP002028454 & SU 1 729 529 A (DOLGOVIDOV & AL) * abstract * ---	1,6,8, 10,22		
X A	US 4 200 673 A (STEELE) * column 1, line 58 - column 2, line 29 * * column 2, line 58 - column 4, line 58 * ---	1,12, 15-17 14		TECHNICAL FIELDS SEARCHED (Int.Cl.6)
X	DE 31 08 921 A (WYMANN) * page 7, line 21 - page 8, line 3; figures * ---	1-3,8,9, 11		E04B C09K
Y	US 4 720 414 A (BURGA) * column 3, line 18 - line 50 * * column 1, line 66 - column 2, line 15 * ---	4		
Y	GB 1 387 582 A (KAINES) * the whole document * ---	20		
A	EP 0 062 298 A (FIBERGLASS CANADA INC.) * page 11, line 21 - page 12, line 27; figures 1,2 * ---	1-3,6-8, 11		
-/--				
The present search report has been drawn up for all claims				
Place of search		Date of completion of the search	Examiner	
THE HAGUE		1 April 1997	Porwoll, H	
CATEGORY OF CITED DOCUMENTS				
X : particularly relevant if taken alone		T : theory or principle underlying the invention		
Y : particularly relevant if combined with another document of the same category		E : earlier patent document, but published on, or after the filing date		
A : technological background		D : document cited in the application		
O : non-written disclosure		L : document cited for other reasons		
P : intermediate document		& : member of the same patent family, corresponding document		



European Patent
Office

EUROPEAN SEARCH REPORT

Application Number
EP 96 83 0547

DOCUMENTS CONSIDERED TO BE RELEVANT			
Category	Citation of document with indication, where appropriate, of relevant passages	Relevant to claim	CLASSIFICATION OF THE APPLICATION (Int.Cl.6)
A	GB 2 023 452 A (BFG GLASSGROUP) * page 2, line 79 - line 128 * ---	1-3,6-8, 10	
A	GB 2 161 185 A (LLOYD-JONES) * the whole document * ---	1,6,8,9, 14	
A	EP 0 296 037 A (AIRCAL S.A.) * column 3, line 26 - column 5, line 47; figures 1,2 * ---	23	
A	FR 2 239 566 A (OPENROLL SARL) * page 4, line 23 - page 5, line 34; figures * ---	23	
A	DATABASE WPI Week 8907 21 September 1988 Derwent Publications Ltd., London, GB; AN 89047234 XP002028455 & DD 260 217 A (HANDELSHOCH. LEIPZIG) * abstract * -----	23	
The present search report has been drawn up for all claims			TECHNICAL FIELDS SEARCHED (Int.Cl.6)
Place of search THE HAGUE		Date of completion of the search 1 April 1997	Examiner Porwoll, H
CATEGORY OF CITED DOCUMENTS X : particularly relevant if taken alone Y : particularly relevant if combined with another document of the same category A : technological background O : non-written disclosure P : intermediate document		T : theory or principle underlying the invention E : earlier patent document, but published on, or after the filing date D : document cited in the application L : document cited for other reasons & : member of the same patent family, corresponding document	

EPO FORM 1503 03.82 (F04C01)