



(12) **EUROPEAN PATENT APPLICATION**

(43) Date of publication:
 03.06.1998 Bulletin 1998/23

(51) Int. Cl.⁶: **A47L 9/28**

(21) Application number: **96119228.3**

(22) Date of filing: **29.11.1996**

(84) Designated Contracting States:
DE FR GB

• **Yoshikawa, Jun**
 Kyoto-shi, Kyoto 601-12 (JP)

(71) Applicant:
YASHIMA ELECTRIC CO., Ltd.
 Kyoto-shi, Kyoto 601 (JP)

(74) Representative:
Prüfer, Lutz H., Dipl.-Phys. et al
PRÜFER & PARTNER,
Patentanwälte,
Harthausen Strasse 25d
81545 München (DE)

(72) Inventors:
 • **Imamura, Nobuo**
 Kyoto-shi, Kyoto 607 (JP)

(54) **Vacuum cleaner**

(57) A vacuum cleaner includes an optical dust sensor (3) for detecting a quantity of dust which sensor is provided at a predetermined position of a suction path (73) for sucking air by a suction force of the vacuum cleaner, an output signal is supplied to a display device (2) so that a display corresponding to the quantity of the sucked dust, which signal is output from the optical dust sensor and is varied in stageless condition corresponding to the quantity of the dust.

Fig.1

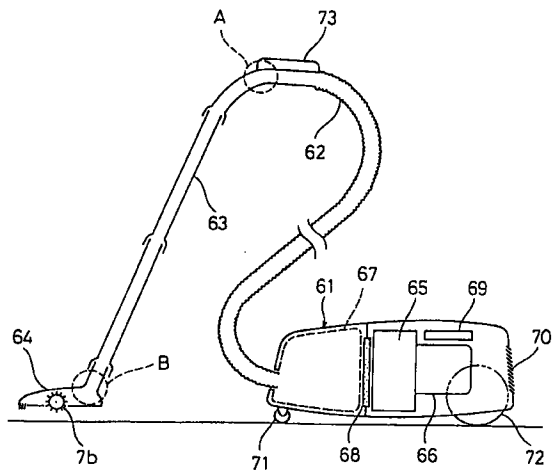

Description

Background of The Invention

The present invention relates to a vacuum cleaner, and more particularly to a vacuum cleaner which detects a quantity of dust and visually displays the detected quantity of dust.

From past, a vacuum cleaner is strongly demanded for improving its functions similarly to other electrified products. It is proposed and is realized to respond the demand for improving its functions, that a dust sensor is provided to a vacuum cleaner. Specifically, a dust sensor for detecting a quantity of sucking dust is provided at a predetermined position of a suction path, and a detection output of the dust sensor, that is the quantity of dust is displayed by two stages (refer to U.S. Patent No. 4,601,082).

When the vacuum cleaner having the arrangement is employed, a quantity of dust included within an air sucked through the suction path is detected during an operating period of the vacuum cleaner, and it is displayed that a quantity of dust is great or small (including a case in which the quantity of dust is zero).

But, dust includes dust of various shapes and sizes such as small sized particles, comparatively large sized particles, cotton dust and others. And, these various dust varies their percentages depending upon a place to be cleaned. It is almost impossible that which kind of dust has the greatest percentage and that how much is the greatest percentage.

Therefore, a disadvantage may arise in that a display is made to show a great quantity of dust despite of the quantity of dust is small in actual depending upon a shape and size of the dust when it is displayed that the quantity of dust is great or small, for example. That is, a detection output of a dust sensor is compared with a predetermined threshold value, and it is displayed depending upon a relationship in size between the detection output and the threshold value that a quantity of dust is great or small, for displaying a quantity of dust by two steps. Consequently, the above disadvantage may arise.

Further, it may be thought that a threshold value is varied in correspondence to a shape and size of dust, but another disadvantage arises in that an operation for varying the threshold value is needed. And, when an operator forgets the operation, the above disadvantage occurs. Furthermore, a further disadvantage arises in that an extra operation for determining plural threshold values previously, which values are to be selected by an operator.

Further, an extra power supply is needed for performing detection of a quantity of dust by a dust sensor, comparison of a detection output and a predetermined threshold value, display based upon the comparison result. And, a dry battery is generally employed as the power supply. A yet disadvantage arises in that the dry

battery is to be exchanged to a new dry battery. Furthermore, when an operator forgets exchanging of the dry battery, it is impossible to perform detection and display of a quantity of dust.

The present invention was made in view of the above problems.

It is an object of the present invention to display a quantity of dust in stageless condition from zero condition, that is, a display is varied continuously depending upon a continuous variation of a quantity of dust.

Summary of The Invention

A vacuum cleaner according to the present invention is a vacuum cleaner which generates a suction force by driving a motor provided within a vacuum cleaner body, and sucks dust with an air through an air suction path member connected to the vacuum cleaner body. And, the vacuum cleaner comprises an optical dust sensor for optically detecting a quantity of dust which sensor is provided at a predetermined position of the air suction path member, and a display device driven by an output from the optical dust sensor in stageless condition.

When the vacuum cleaner having the arrangement is employed, a quantity of dust is optically detected which is sucked with an air, and a display is driven in stageless condition based upon an output from the optical dust sensor. Therefore, decrease in quantity of dust is displayed in stageless condition following a cleaning operation. And, no threshold values are needed, and the above disadvantages due to necessity of threshold values are prevented from occurrence, because decrease in quantity of dust is displayed in stageless condition.

It is preferable that a vacuum cleaner according to the present invention employs a fan driven by a suction force and an electric generator driven by the fan as a power source for driving an optical dust sensor, a display and the like.

When the vacuum cleaner is employed, the above disadvantages are prevented from occurrence which disadvantages arise when a dry battery is employed as a power source.

Brief Description of The Drawings

Figure 1 is a diagram schematically showing an arrangement of a vacuum cleaner according to the present invention;

Figure 2 is a plan view showing a floor nozzle pipe and a cover member;

Figure 3 is a front view showing a floor nozzle pipe and a cover member;

Figure 4 is a side view showing a floor nozzle pipe and a cover member;

Figure 5 is a vertical cross sectional view showing an interior arrangement of a floor nozzle pipe and a cover member;

Figure 6 is a block diagram showing an electrical arrangement of a main portion of a vacuum cleaner according to the present invention;

Figure 7 is an electrical circuit diagram showing the arrangement in Fig. 6 in more detail;

Figure 8 is a block diagram showing another electrical arrangement of a main portion of a vacuum cleaner according to the present invention;

Figure 9 is a block diagram showing a further electrical arrangement of a main portion of a vacuum cleaner according to the present invention;

Figure 10 is a block diagram showing a yet electrical arrangement of a main portion of a vacuum cleaner according to the present invention;

Figure 11 is a block diagram of a main portion of a dust detection and display apparatus of a modified example;

Figure 12 is a block diagram showing yet another electrical arrangement of a main portion of a vacuum cleaner according to the present invention;

Figure 13 is an electrical circuit diagram showing in more detail a dust detection and display apparatus illustrated in Fig. 6;

Figures 14 are vertical cross sectional view showing arrangements of a display device; and

Figure 15 is a vertical cross sectional view schematically showing an arrangement of a display device.

Brief Description of Preferred Embodiments

Figure 1 is a diagram schematically showing an arrangement of a vacuum cleaner according to the present invention.

The vacuum cleaner comprises a vacuum cleaner body 61, a hose 62 having a bellows shape, an extension pipe 63 provided at a leading edge section of the hose 62 in a removable manner, and a floor nozzle 64 provided at a leading edge section of the extension pipe 63.

The vacuum cleaner body 61 includes a suction fan 65, a motor 66 for driving the suction fan 65, a dust bag 67 for collecting sucked dust, a filter 68 for collecting fine dust which is not collected by the dust bag 67, a motor control section 69 for controlling the motor 66 causing varying of a suction force, an exhaust opening 70, a caster 71, and wheels 72.

The floor nozzle 64 includes a floor nozzle pipe 73 for connecting the floor nozzle 64 to the extension pipe 63. The floor nozzle pipe 73 includes a non-inclination section 74 and an inclination section 75 by being inclined an edge-ward predetermined extent of the floor nozzle pipe 73, as is illustrated in Figs. 2 through 4. The floor nozzle pipe 73 performs connection of the floor nozzle 64 to the extension pipe 63. Also, the floor nozzle pipe 73 easily lay the floor nozzle 64 on a floor and the like without a forced posture of an operator when the operator performs cleaning by grasing the extension pipe 63, for example. Further, the floor nozzle pipe 73

includes a cover member 76 which bridges across the non-inclination section 74 and the inclination section 75. The cover member 76 includes therein an electrical circuitry for detecting and visially displaying a quantity of sucked dust, and includes a suction opening 77 and a display section 78.

Figure 5 is a vertical cross sectional view showing an interior arrangement of the floor nozzle pipe 73 and the cover member 76.

The floor nozzle pipe 73 includes a light emitting device 79 such as a light emitting diode and the like and a light receiving device 80 such as a phototransistor and the like (the light emitting device 79 and the light receiving device 80 consist a dust sensor 3). The light emitting device 79 and the light receiving device 80 are opposite to one another in a direction which crosses an air flowing direction within the floor nozzle pipe 73 by a right angle. A light radiation face of the light emitting device 79 and a light receiving face of the light receiving device 80 are determined to be almost the same height with an inner face of the floor nozzle pipe 73. Therefore, a quantity of light which reaches the light receiving device 80 among dariated light from the light emitting device 79, is decreased by dust included within an air flow so that a quantity of dust is detected based upon an output signal from the light receiving device 80.

The cover member 76 includes therein a dust sensor circuitry section 81 for performing processing based upon an output signal from the dust sensor 3, a rotatable turbin wheel 82 provided at a position which is close to the suction opening 77, a d.c. electric generator 1 driven by the rotatable turbin wheel 82, and a display device 2 such as light emitting diode and the like which is driven based upon an output signal from the dust sensor circuitry section 81.

Figure 6 is a block diagram showing an electrical arrangement of a main portion of a vacuum cleaner according to the present invention.

As is illustrated in Fig. 6, a dust detection and display apparatus of a vacuum cleaner according to the present invention amplifies an output signal from the dust sensor 3 using an amplifier 4, then obtains a d.c. voltage using a rectification circuitry 5, converts the d.c. voltage into a d.c. current using a voltage-current converter circuitry (driving circuitry) 6, and thereafter supplies the converted d.c. current to the display device 2. Then, the dust detection and display apparatus feed-backs an output signal from a correction circuitry 7 to the dust sensor 3, the correction circuitry 7 being input the output signal from the dust sensor 3, so that a quantity of radiating light of the light emitting device 79 of the dust sensor 3. Therefore, a misoperation due to varying of a quantity of radiating light is prevented from occurence. Further, a d.c. electric generator 1 is provided for supplying an operation voltage to the dust sensor 3, amplifier 4, voltage-current converter circuitry 6, and display device 2, the d.c. electric generator 1 being not illustrated in Fig. 6.

Figure 7 is an electrical circuit diagram showing the arrangement in Fig. 6 in more detail.

A Zener diode ZD1 and a capacitor C1 are connected in parallel between both terminals of the d.c. electric generator G. A Zener diode ZD2 and a capacitor C2 are connected in parallel between both terminals of the d.c. electric generator G through a resistor R1. A resistor R2, a phototransistor Q1 as the light receiving device 80, and a resistor R3 are connected in serial between both terminals of the capacitor C2. A capacitor C3 is connected parallelly to the resistor R2. The correction circuitry 7 is connected between both terminals of the capacitor C2. The correction circuitry 7 is supplied a voltage which is a voltage at a connecting point of the phototransistor Q1 and the resistor R3. A light emitting diode LED1 is connected between output terminals of the correction circuitry 7.

Further, a resistor R4, a resistor R5, and a diode D1 are connected in serial between both terminals of the capacitor C2. A connecting point of the resistors R4 and R5 is connected to a non-reversed input terminal of an operational amplifier IC1-1, and a connecting point of the phototransistor Q1 and the resistor R3 is connected to a reversed input terminal of the operational amplifier IC1-1 through a capacitor C4. A resistor R7 is connected between the non-reversed input terminal and an output terminal of the operational amplifier IC1-1.

A diode D2 and a resistor R8 are connected in serial to the output terminal of the operational amplifier IC1-1, and a capacitor C5 and a resistor R9 are connected in parallel between the resistor R8 and a negative output terminal of the d.c. electric generator G.

Furthermore, a connecting point of the resistor R8 and the capacitor C5 is connected to a non-reversed input terminal of an operational amplifier IC1-2, the negative output terminal of the d.c. electric generator G is connected to a reversed input terminal of the operational amplifier IC1-2 through a resistor R10. An output terminal of the operational amplifier IC1-2 is connected to a base terminal of a transistor Q2. And, a light emitting diode LED2 is connected between a positive output terminal of the d.c. electric generator G and a collector terminal of the transistor Q2. A resistor R12 is connected between the negative output terminal of the d.c. electric generator G and an emitter terminal of the transistor Q2. A resistor R11 is connected between the reversed input terminal of the operational amplifier IC1-2 and the emitter terminal of the transistor Q2.

When the dust detection and display apparatus having the above arrangement is employed, a light radiated from the light emitting device 79 is received by the light receiving device 80. An output signal from the light receiving device 80 (a voltage at the connecting point of the phototransistor Q1 and the resistor R3) is amplified by the operational amplifier IC1-1, then rectified by the diode D2, thereafter the d.c. voltage is converted into a d.c. current by the voltage-current converter circuitry 6. The converted d.c. current is supplied to the display

device 2. And, a quantity of light which is received by the light receiving device 80 varies depending upon a quantity of dust included within an air which passes through the floor nozzle pipe 73. That is, when a quantity of dust is small, a quantity of received light is great, and when a quantity of dust is great, a quantity of received light is small. Therefore, an output signal corresponds to a quantity of sucked dust. And, the output signal is supplied to the display device 2 after being applied predetermined processings by the amplifier 4 and the voltage-current converter circuitry 6.

A d.c. current supplied to the display device 2 is not performed a processing based upon a threshold value at all, therefore the d.c. current corresponds to a quantity of dust and the d.c. current varies in correspondence to variation of a quantity of dust within an air which passes through the floor nozzle pipe 73. That is, the d.c. current supplied to the display device 2 varies in stageless condition depending upon the variation in quantity of dust. Consequently, threshold values are not necessarily determined at all, determination of optimum threshold values being difficult and an operation for determining optimum threshold values being extremely complicated. The d.c. current supplied to the display device 2 varies in stageless condition corresponding to variation in quantity of dust so that a quantity of dust within an air which passes through the floor nozzle pipe 73 is securely displayed, in its turn it can be displayed that cleaning has finished, despite of no threshold values being employed.

Further, under a condition that the suction fan 65 of the vacuum cleaner is driven, an air is also sucked through the suction opening 77. The rotatable turbin wheel 82 is rotated by an air sucked through the suction opening 77. The rotatable turbin wheel 82 drives the d.c. electric generator G so that an operation voltage for the dust detection and display apparatus is generated. Therefore, an operation for exchanging a dry battery with new one is not necessary at all which operation is necessary when a dry battery is employed as a power source. Of course, disadvantages due to forgetting of exchanging of a dry battery are prevented from occurrence.

Figure 8 is a block diagram showing another electrical arrangement of a main portion of a vacuum cleaner according to the present invention.

An dust detection and display apparatus illustrated in Fig. 8 differs from the dust detection and display apparatus illustrated in Fig. 6 in that a pulse width modulation circuitry 8 which receives the output signal from the rectification circuitry 5, and a driver circuitry 9 which receives a pulse width modulation signal output from the pulse width modulation circuitry 8 are employed instead of the voltage-current converter circuitry 6.

When the dust detection and display apparatus illustrated in Fig. 8 is employed, the pulse width modulation circuitry 8 performs pulse width modulation in correspondence to an output signal from the rectification

circuitry 5 so as to output a pulse width modulation signal. And, the driver circuitry 9 receives the pulse width modulation signal and outputs a driving signal for driving the display device 2 therefrom.

Consequently, similarly to the dust detection and display apparatus illustrated in Fig. 6, threshold values are not necessarily determined at all, and the driving signal supplied to the display device 2 varies in stageless condition corresponding to variation in quantity of dust so that a quantity of dust within an air which passes through the floor nozzle pipe 73 is securely displayed, in its turn it can be displayed that cleaning has finished, despite of no threshold values being employed.

Further, under a condition that the suction fan 65 of the vacuum cleaner is driven, an air is also sucked through the suction opening 77. The rotatable turbin wheel 82 is rotated by an air sucked through the suction opening 77. The rotatable turbin wheel 82 drives the d.c. electric generator G so that an operation voltage for the dust detection and display apparatus is generated. Therefore, an operation for exchanging a dry battery with new one is not necessary at all which operation is necessary when a dry battery is employed as a power source. Of course, disadvantages due to forgetting of exchanging of a dry battery are prevented from occurrence.

Figure 9 is a block diagram showing a further electrical arrangement of a main portion of a vacuum cleaner according to the present invention.

An dust detection and display apparatus illustrated in Fig. 9 differs from the dust detection and display apparatus illustrated in Fig. 6 in that a voltage controlled oscillator 10 which receives an output signal from the rectification circuitry 5, and a driver circuitry 9 which receives an oscillation signal output from the voltage controlled oscillator 10 are employed instead of the voltage-current converter circuitry 6.

When the dust detection and display apparatus illustrated in Fig. 9 is employed, the voltage controlled oscillator 10 performs oscillation in correspondence to an output signal (output voltage) from the rectification circuitry 5 so as to output an oscillation signal, and the driver circuitry 9 receives the oscillation signal and outputs a driving signal for driving the display device 2.

Consequently, similarly to the dust detection and display apparatus illustrated in Fig. 6, threshold values are not necessarily determined at all, and the driving signal supplied to the display device 2 varies in stageless condition corresponding to variation in quantity of dust so that a quantity of dust within an air which passes through the floor nozzle pipe 73 is securely displayed, in its turn it can be displayed that cleaning has finished, despite of no threshold values being employed.

Further, under a condition that the suction fan 65 of the vacuum cleaner is driven, an air is also sucked through the suction opening 77. The rotatable turbin wheel 82 is rotated by an air sucked through the suction opening 77. The rotatable turbin wheel 82 drives the

d.c. electric generator G so that an operation voltage for the dust detection and display apparatus is generated. Therefore, an operation for exchanging a dry battery with new one is not necessary at all which operation is necessary when a dry battery is employed as a power source. Of course, disadvantages due to forgetting of exchanging of a dry battery are prevented from occurrence.

Figure 10 is a block diagram showing a yet electrical arrangement of a main portion of a vacuum cleaner according to the present invention.

An dust detection and display apparatus illustrated in Fig. 9 differs from the dust detection and display apparatus illustrated in Fig. 6 in that a driver circuitry 11 and a reversed driver circuitry 12 both receive an output signal from the rectification circuitry 5 are employed instead of the voltage-current converter circuitry 6, and that a display device 2a driven by the driver circuitry 11 and a display device 2b driven by the reversed driver circuitry 12 are employed instead of the display device 2.

When the dust detection and display apparatus illustrated in Fig. 10 is employed, an output signal from the rectification circuitry 5 is simultaneously supplied to the driver circuitry 11 and the reversed driver circuitry 12. The driver circuitry 11 outputs a signal so as to drive the display device 2a which signal is in proportion to the output signal from the rectification circuitry 5, and the reversed driver circuitry 12 outputs a signal so as to drive the display device 2b which signal is in reversed proportion to the output signal from the rectification circuitry 5. In this case, the display device 2a and the display device 2b are driven by signals which represent reversed variation to one another. Therefore, when a quantity of dust is increased, for example, the display device 2a lights brighter, while the display device 2b lights darker. Further, a quantity of dust can be displayed as a variation in color by determining a display color of the display device 2a and a display color of the display device 2b, both colors being different from one another, and by providing both display devices 2a and 2b within a single mold 2e as is illustrated in Fig. 15.

Consequently, similarly to the dust detection and display apparatus illustrated in Fig. 6, threshold values are not necessarily determined at all, and the driving signal supplied to the display device 2 varies in stageless condition corresponding to variation in quantity of dust so that a quantity of dust within an air which passes through the floor nozzle pipe 73 is securely displayed, in its turn it can be displayed that cleaning has finished, despite of no threshold values being employed.

Further, under a condition that the suction fan 65 of the vacuum cleaner is driven, an air is also sucked through the suction opening 77. The rotatable turbin wheel 82 is rotated by an air sucked through the suction opening 77. The rotatable turbin wheel 82 drives the d.c. electric generator G so that an operation voltage for the dust detection and display apparatus is generated. Therefore, an operation for exchanging a dry battery

with new one is not necessary at all which operation is necessary when a dry battery is employed as a power source. Of course, disadvantages due to forgetting of exchanging of a dry battery are prevented from occurrence.

Figure 11 is a block diagram of a main portion of a dust detection and display apparatus of a modified example.

In the dust detection and display apparatus, the display devices 2a and 2b are connected in serial to one another, and an output signal from a driver circuitry 10 which receives an output signal from the rectification circuitry 5 is supplied to a connecting point of the display device 2a and the display device 2b.

When the dust detection and display apparatus illustrated in Fig. 11 is employed, simplification in arrangement following omission of a reversed driver circuitry 12 is performed in comparison to the dust detection and display apparatus illustrated in Fig. 10. And, the dust detection and display apparatus illustrated in Fig. 11 performs similar operation to that of the dust detection and display apparatus illustrated in Fig. 10.

Figure 12 is a block diagram showing yet another electrical arrangement of a main portion of a vacuum cleaner according to the present invention.

The dust detection and display apparatus illustrated in Fig. 12 differs from the dust detection and display apparatus illustrated in Fig. 10 in that a lens 13 is further provided for mixing a display of the display device 2a and a display of the display device 2b.

When the dust detection and display apparatus illustrated in Fig. 12 is employed, simple display devices can be employed as the display device 2a and the display device 2b, respectively. Therefore, freedom in selecting a display device is improved. And, the dust detection and display apparatus illustrated in Fig. 12 performs similar operation to that of the dust detection and display apparatus illustrated in Fig. 10.

Figure 13 is an electrical circuit diagram showing in more detail a dust detection and display apparatus illustrated in Fig. 6.

The electrical circuit diagram illustrated in Fig. 13 differs from the electrical circuit diagram illustrated in Fig. 7 in that a variable resistor R13 is employed instead of the resistor R12 which is connected to the transistor Q2 in serial.

The variable resistor R13 may be any type of resistors which can be varied its resistance value such that a variable resistor which is manually varied its resistance value in stageless condition, a resistance circuitry which is manually selected one of a plurality of resistance values previously determined, a resistance device or a resistance circuitry which receives a resistance value changing command and varies its resistance value in a stageless condition, a resistance device or a resistance circuitry which receives a resistance value changing command and selects one of a plurality of resistance values previously determined, and the like.

When the dust detection and display apparatus illustrated in Fig. 13 is employed, even when a predetermined quantity of dust is detected, a display by the display device 2 is varied brighter or darker in comparison to a display by the dust detection and display apparatus illustrated in Fig. 7 by varying the resistance value of the variable resistor R13. Therefore, a dust detection sensitivity can be adjusted. Consequently, an optimum dust detection sensitivity can be obtained which matches species of cleaning location (species such as a board floor, a tatami mat, a carpet and the like), a suction force of a vacuum cleaner and the like. Of course, the dust detection and display apparatus illustrated in Fig. 13 performs similar operation to that of the dust detection and display apparatus illustrated in Fig. 7.

Further, a modification similar to the modification illustrated in Fig. 13 (employing of the variable resistor) is applicable to one of the dust detection and display apparatus illustrated in Fig. 8 through Fig. 12.

Furthermore, the dust detection and display apparatus illustrated in Fig. 6 through Fig. 13 are provided to the floor nozzle pipe 73. But, the dust detection and display apparatus illustrated in Fig. 6 through Fig. 13 are possibly provided at an arbitrary position of a path which sucks an air following cleaning, such as a predetermined position of the hose 62 having a bellows shape, a predetermined position of the extension pipe 63 and the like.

Figures 14 are vertical cross sectional view showing arrangements of a display device.

In Fig. 14(A), a light emitting diode 2 is employed as the display device 2 and a transparent flat membrane 2c is provided at a position which is close to a light emitting face of the light emitting diode 2.

When this arrangement is employed, a display is easily recognized from just above position of the transparent flat membrane 2c.

In Fig. 14(B), a light emitting diode 2 is employed as the display device 2 and a transparent curved (projected) membrane 2d is provided at a position which is close to a light emitting face of the light emitting diode 2.

When this arrangement is employed, a display is easily recognized not only just above position of the transparent curved membrane 2d but also side-ward position of the transparent curved membrane 2d.

The present invention is not limited to the attached drawings and the embodiments. Many modifications and variations are possible within the scope of the present invention.

Claims

1. A vacuum cleaner comprising;

dust suction path means (73) for passing dust and air therethrough by a sucking force;

dust sensor means (3) for optically detecting a quantity of sucking dust and for outputting a

- detection signal, the dust sensor means being provided at a predetermined position of the dust suction path means;
- display means (2) for visually displaying the quantity of detected dust; and
- display controlling means for receiving the detection signal from the dust sensor means (3) for outputting and supplying the driving signal to the display means (2), the driving signal being varied in stageless condition in correspondence to the quantity of dust.
2. A vacuum cleaner as set forth in claim 1, further comprising an electrical generator means for generating a voltage which corresponds to the sucking force.
 3. A vacuum cleaner as set forth in claim 1, wherein the display means comprises a light emitting diode (2), and further comprising a variable resistance means (R13) for limiting a current of the light emitting diode (2), the variable resistance means (R13) being connected to the light emitting diode (2) in serial.
 4. A vacuum cleaner as set forth in one of claims 1 to 3, wherein the display means comprises one or more light emitting diodes (2), and further comprising transparent membrane means (2d) which is projectingly curved and is positioned closely to corresponding light emitting diode (2).
 5. A vacuum cleaner as set forth in one of claims 1 to 4, wherein the display controlling means includes amplifier means (4) for amplifying the output signal from the dust sensor means (3) and for providing an output signal therefrom, rectification means (5) for rectifying the output signal from the amplifier means (4) and for providing an output voltage therefrom.
 6. A vacuum cleaner as set forth in claim 5, wherein voltage-current converter means (6) for receiving the output voltage from the rectification means (5) and for providing a corresponding current signal therefrom, or pulse width modulation means (8) for receiving the output signal from the rectification means (5) and for providing corresponding pulse width modulation signal therefrom, and driver means (9) for receiving the pulse width modulation signal and for providing corresponding signal therefrom, or voltage controlled oscillator means (10) for receiving the output voltage from the rectification means (5) and for providing an oscillation signal having a corresponding frequency therefrom, and driver means (9) for receiving the oscillation signal from the voltage controlled oscillator means and for providing corresponding signal therefrom.
 7. A vacuum cleaner as set forth in one of claims 1 to 4, wherein the display means comprises a pair of light emitting diodes (2a, 2b) each having a different display color from one another, and the display controlling means includes amplifier means (4) for amplifying the output signal from the dust sensor means (3) and for providing an output signal therefrom, rectification means (5) for rectifying the output signal from the amplifier means (4) and for providing an output signal therefrom, first driver means (11) for receiving the output signal from the rectification means (5) and for providing and supplying corresponding first signal to one of the light emitting diodes (2a), and second driver means (12) for receiving the output signal from the rectification means and for providing and supplying a second signal to the other light emitting diode (2b), the second signal representing a variation characteristics which is in reverse to a variation characteristics of the first signal.
 8. A vacuum cleaner as set forth in claim 1, wherein the display means (2) comprises a pair of light emitting diodes (2a, 2b), which have different display colors from one another and are connected in serial to one another, and the display controlling means includes amplifier means (4) for amplifying the output signal from the dust sensor means (3) and for providing an output signal therefrom, rectification means (5) for rectifying the output signal from the amplifier means (4) and for providing an output signal therefrom, and driver means (9) for receiving the output signal from the rectification means (5) and for providing and supplying corresponding signal to a connecting point of the pair of light emitting diodes (2a, 2b).
 9. A vacuum cleaner as set forth in claim 7 or 8, wherein the pair of light emitting diodes (2a, 2b) are provided within a single mold (2e).
 10. A vacuum cleaner as set forth in claim 7 or 8, further comprising a lens (13) for mixing lights radiated from the pair of light emitting diodes (2a, 2b).

Fig.1

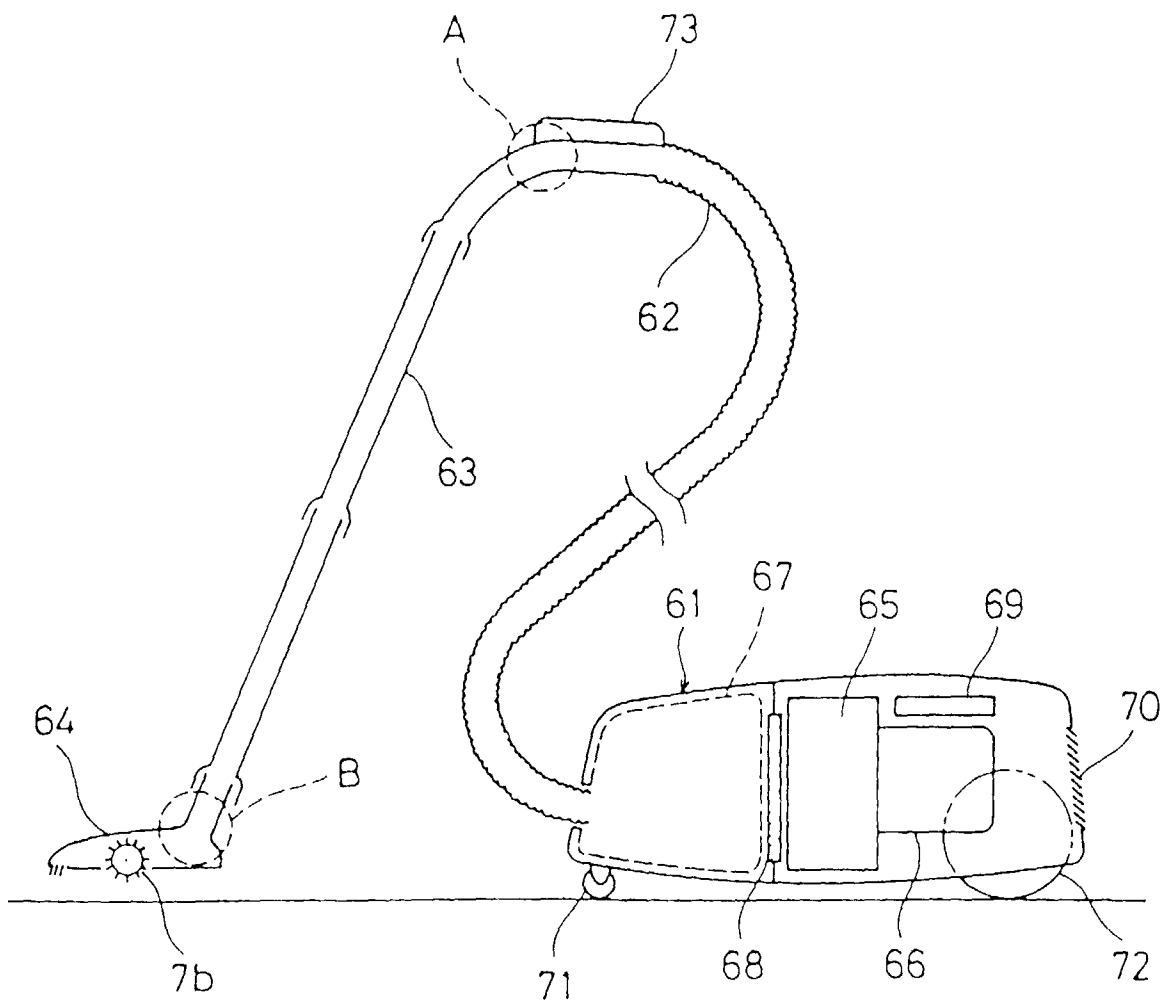

Fig.2

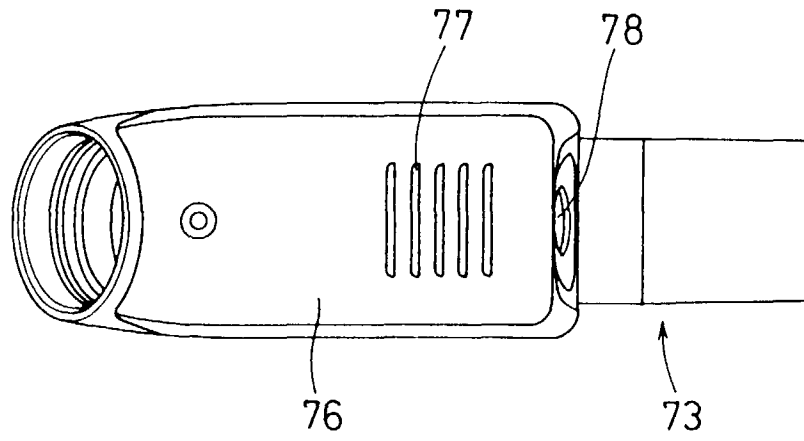

Fig.3

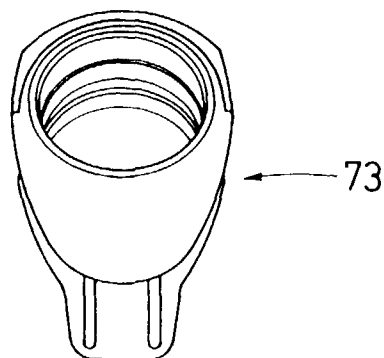

Fig.4

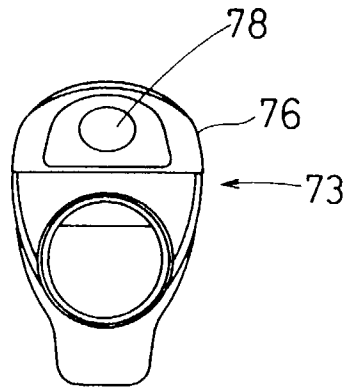

Fig.5

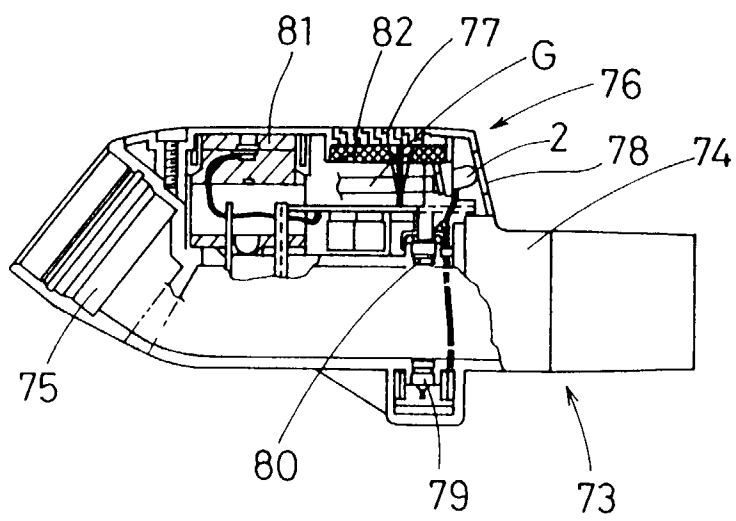

Fig.6

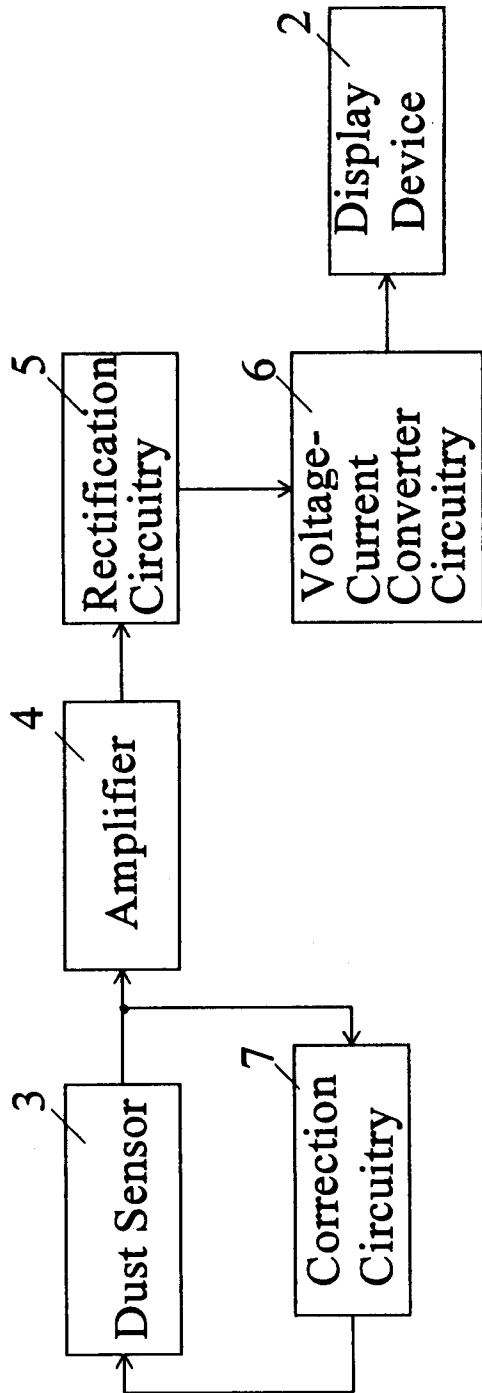

Fig. 7

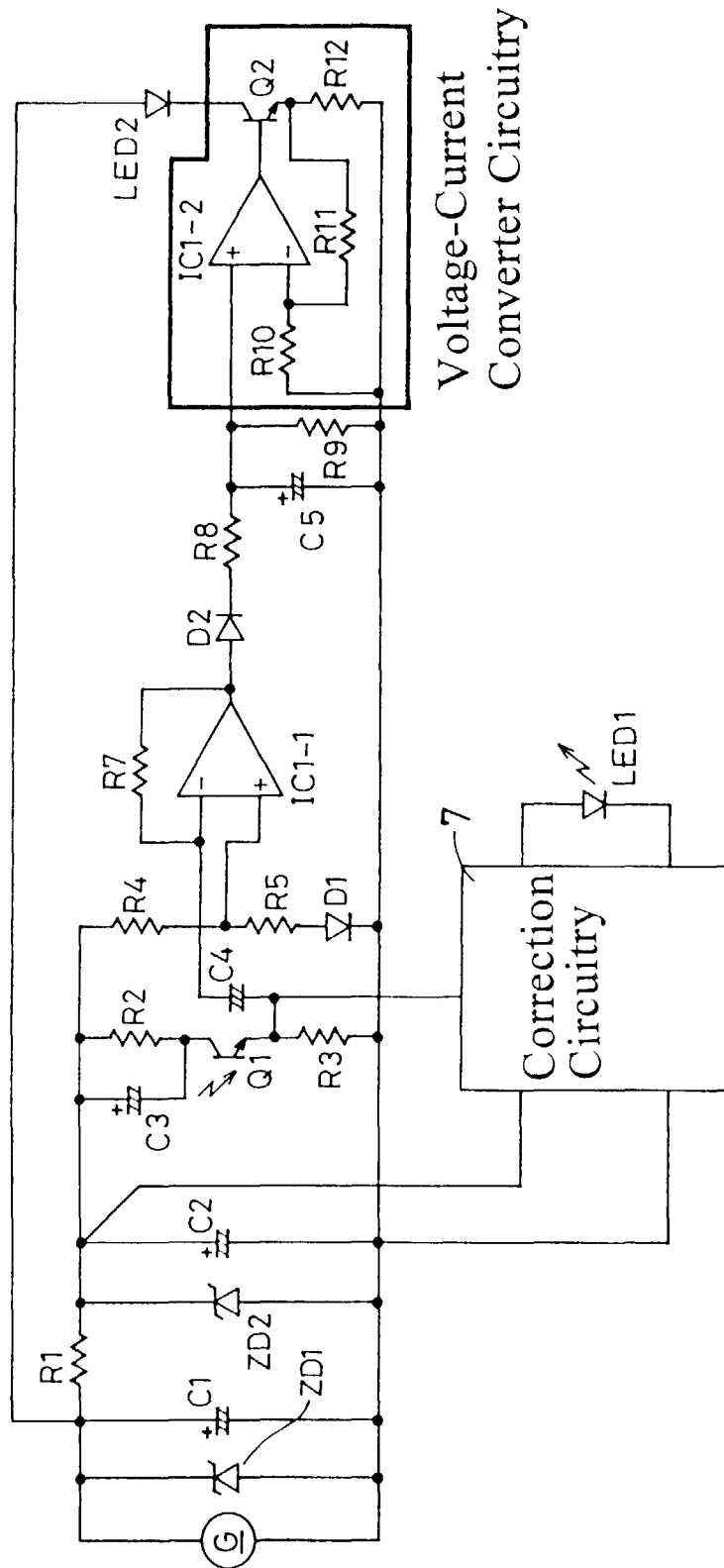

Fig.8

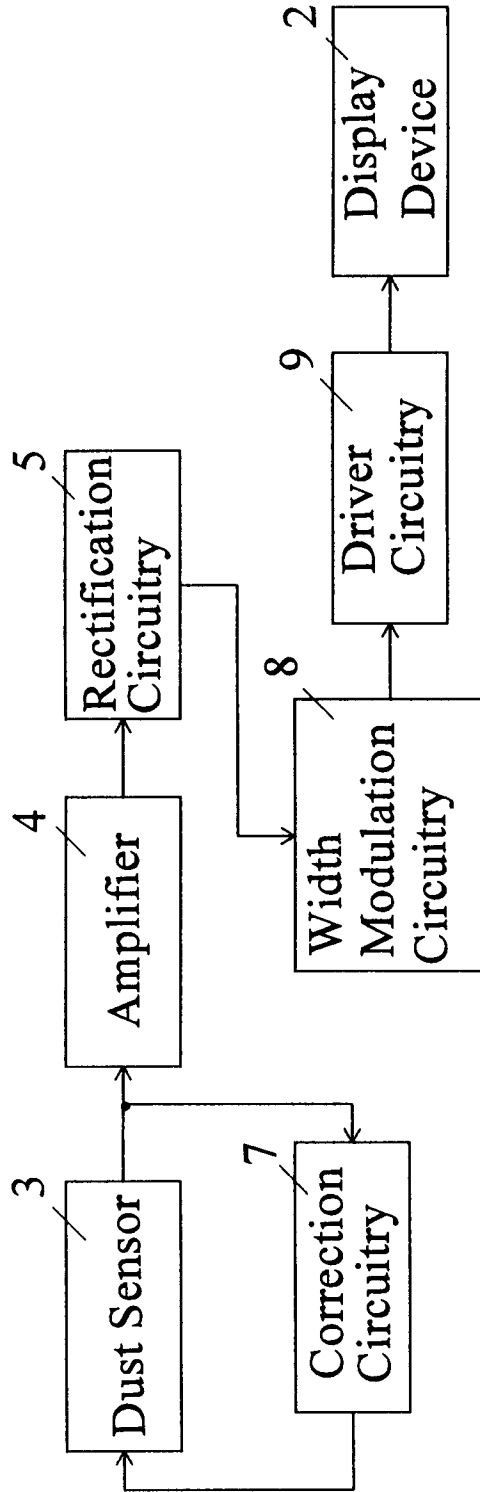

Fig.9

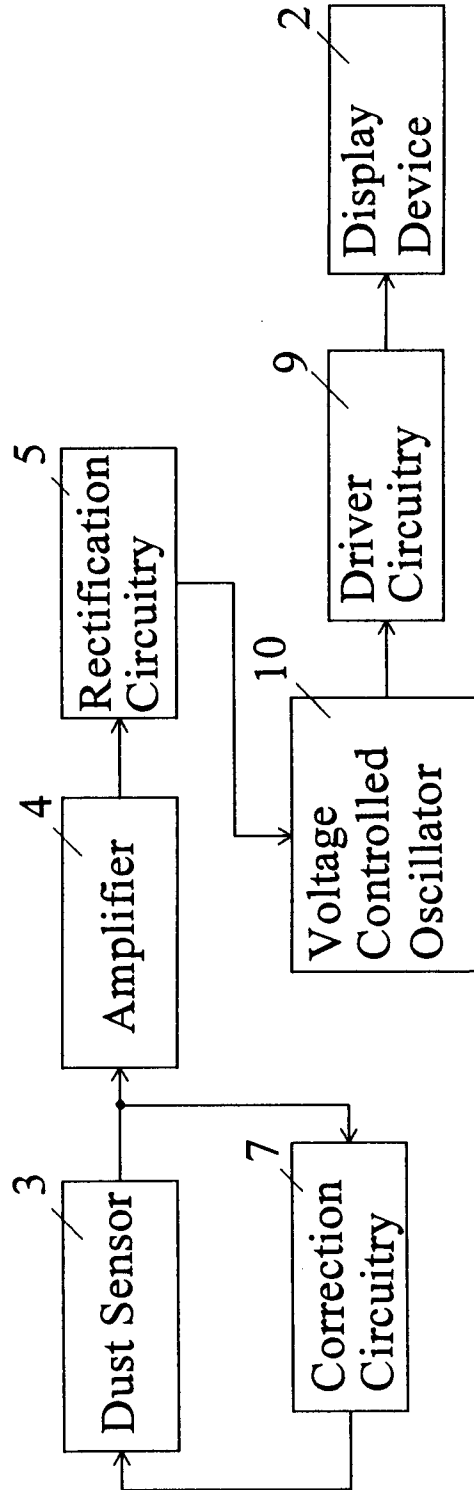

Fig. 10

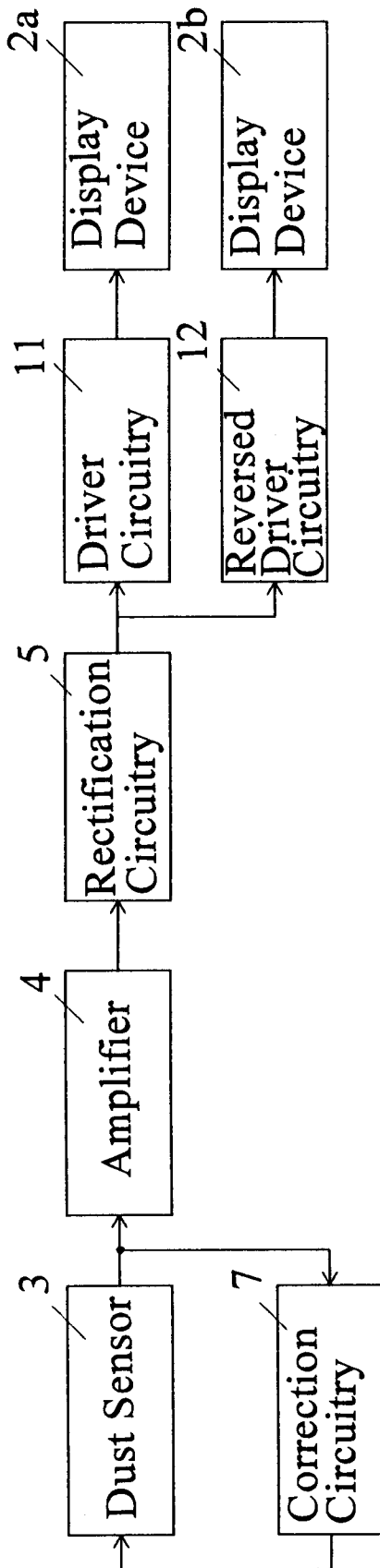

Fig.11

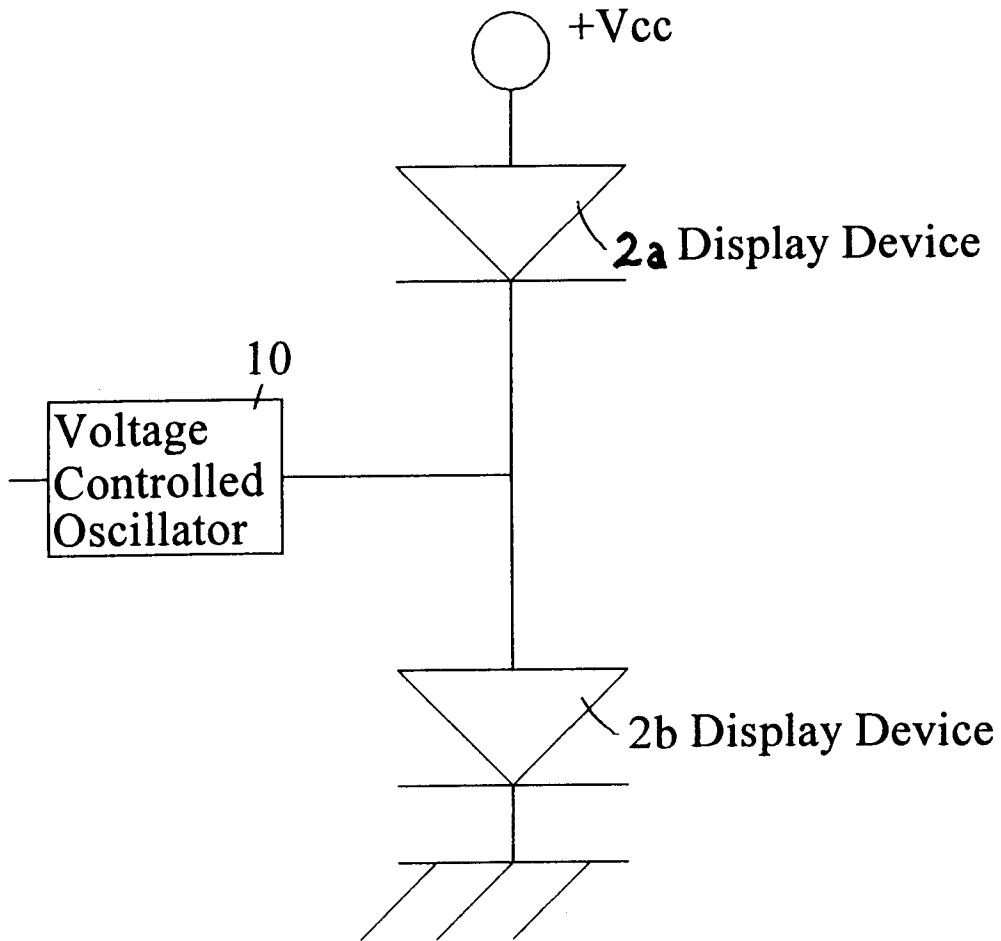

Fig.12

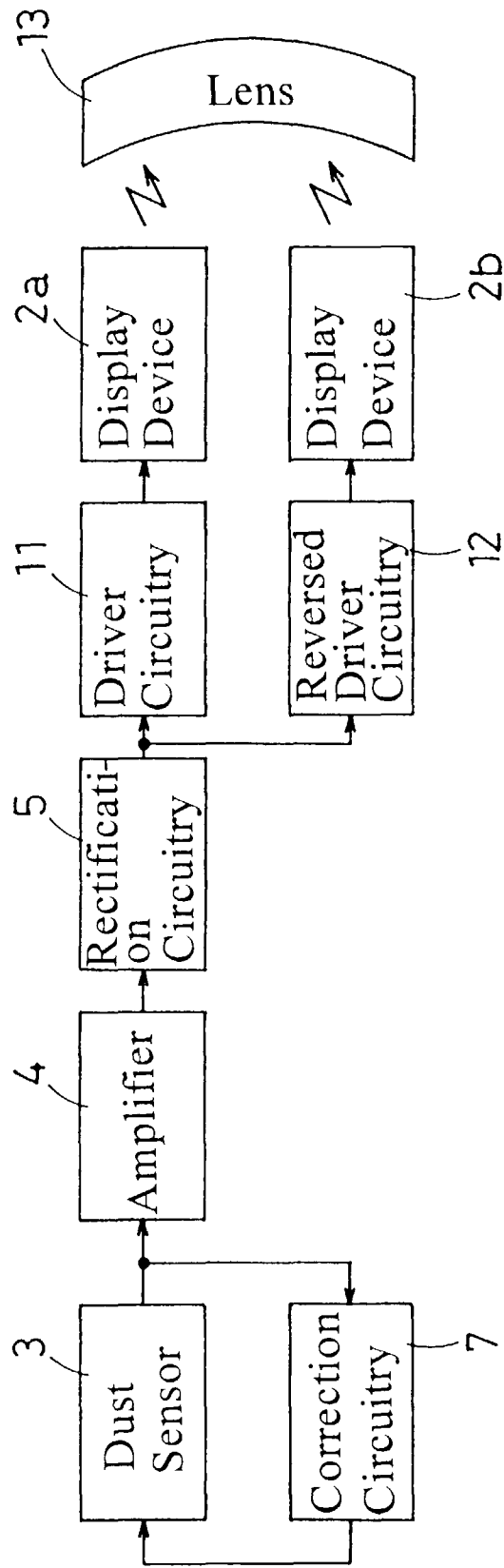

Fig.13

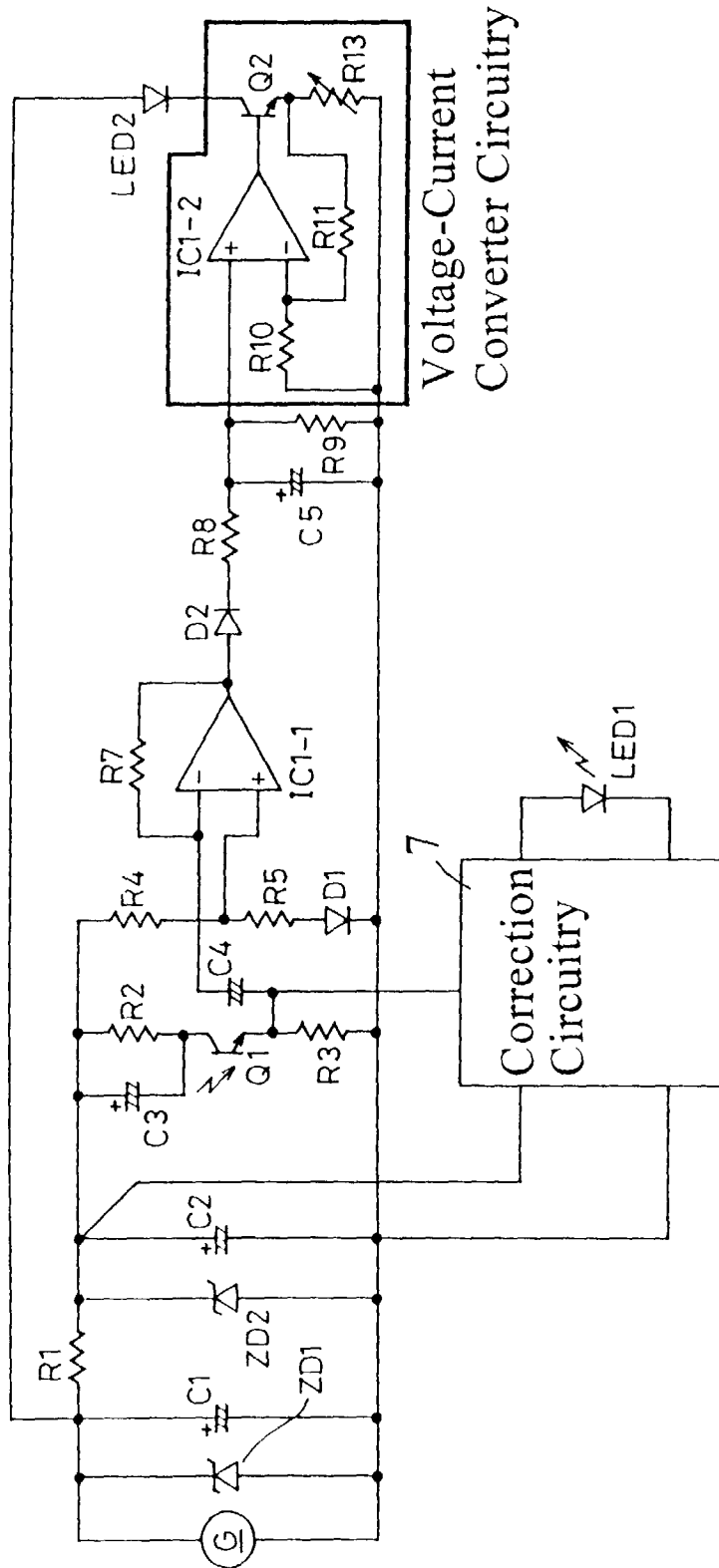

Fig.14

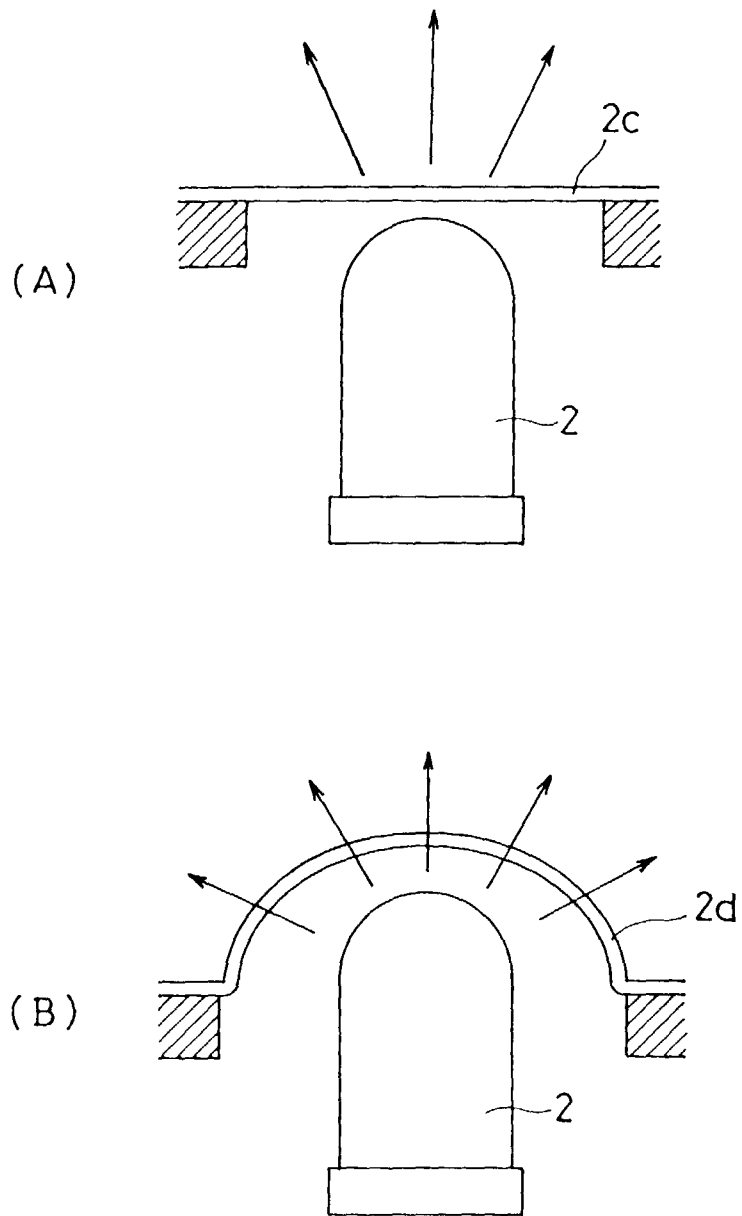
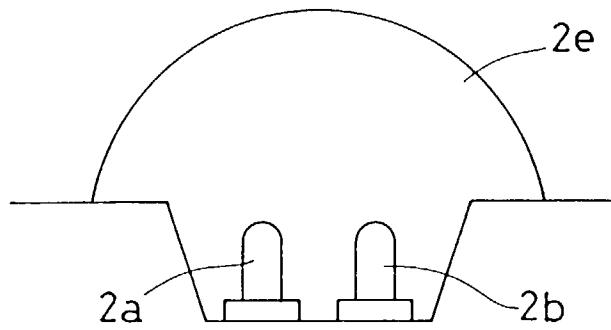

Fig.15





European Patent
Office

EUROPEAN SEARCH REPORT

Application Number
EP 96 11 9228

DOCUMENTS CONSIDERED TO BE RELEVANT				
Category	Citation of document with indication, where appropriate, of relevant passages	Relevant to claim	CLASSIFICATION OF THE APPLICATION (Int.Cl.6)	
X	US-A-4 680 827 (HUMMEL KARL) 21 July 1987 * column 1, line 63 - column 2, line 2 * * column 3, line 67 - column 5, line 40 *	1,5,6	A47L9/28	
Y	* column 4, line 17-20; figure 1 * ---	2		
Y	EP-A-0 584 743 (YASHIMA ELECTRIC CO LTD OF ISH) 2 March 1994 * column 3, line 3-7 - column 5, line 44-47 *	2		
A	* column 8, line 57 - column 14, line 30 * ---	1,4		
A	EP-A-0 546 620 (PHILIPS NV) 16 June 1993 * column 4, line 12 - column 5, line 25 * ---	7,8		
A	PATENT ABSTRACTS OF JAPAN vol. 95, no. 010 & JP-A-07 250794 (MATSUSHITA ELECTRIC IND CO LTD), 3 October 1995, * abstract * ---	1		
A	PATENT ABSTRACTS OF JAPAN vol. 018, no. 476 (C-1246), 6 September 1994 & JP-A-06 154133 (MATSUSHITA ELECTRIC IND CO LTD), 3 June 1994, * abstract * -----	1		
The present search report has been drawn up for all claims				TECHNICAL FIELDS SEARCHED (Int.Cl.6)
				A47L
Place of search	Date of completion of the search	Examiner		
MUNICH	5 February 1997	Laue, F		
CATEGORY OF CITED DOCUMENTS		T : theory or principle underlying the invention E : earlier patent document, but published on, or after the filing date D : document cited in the application L : document cited for other reasons & : member of the same patent family, corresponding document		
X : particularly relevant if taken alone Y : particularly relevant if combined with another document of the same category A : technological background O : non-written disclosure P : intermediate document				

EPO FORM 1503 03.82 (P04C01)