

Europäisches Patentamt
European Patent Office
Office européen des brevets



(11) **EP 0 847 030 A2**

(12) **EUROPEAN PATENT APPLICATION**

(43) Date of publication:
10.06.1998 Bulletin 1998/24

(51) Int. Cl.⁶: **G07C 9/00**

(21) Application number: **97121056.2**

(22) Date of filing: **01.12.1997**

(84) Designated Contracting States:
**AT BE CH DE DK ES FI FR GB GR IE IT LI LU MC
NL PT SE**
Designated Extension States:
AL LT LV MK RO SI

(72) Inventors:
• **Boninsegna, Massimo**
38037 Predazzo (Trento) (IT)
• **Virdia, Antonio**
38070 Sopramonte (Trento) (IT)

(30) Priority: **04.12.1996 IT TO960984**

(74) Representative:
Bosotti, Luciano et al
c/o JACOBACCI & PERANI S.p.A.
Corso Regio Parco, 27
10152 Torino (IT)

(71) Applicants:
• **ISTITUTO TRENTOINO DI CULTURA**
I-38100 Trento (IT)
• **Advent S.r.l.**
38100 Trento (IT)

(54) **A method and device for automatically detecting and counting bodies passing through a gap**

(57) A method for automatically detecting and counting bodies passing through a gap (A) includes the steps of monitoring the gap (A) with means for generating image signals (3; 4, 9) to obtain a succession of images (4a, 4b; L₀, L₁, ..., L_N) of each body (B) passing through the gap (A), of processing these images (4a, 4b; L₀, L₁, ..., L_N) to obtain an altimetric map for each body (B) passing through the gap (A) for each moment considered, of comparing at least one altimetric map obtained with at least one model of altimetric map stored in a processing unit (5), and of activating a counting procedure depending on the result of the comparison.

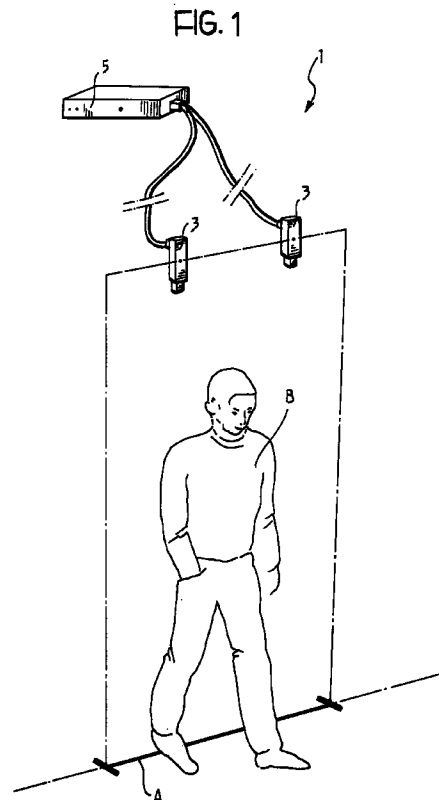

EP 0 847 030 A2

Description

The present invention concerns a method for automatically detecting and counting bodies passing through a gap. In the following description and the accompanying claims, the term gap is to be understood as an imaginary surface, or a linear projection thereof, separating two adjacent areas. It can be a physical gap such as a doorway or gateway, or a logical gap such as a virtual flat surface perpendicular to the floor and walls of a passage which can be visualised, for example, by means of a line along an imaginary communication plane, which may be a floor or a step or ramp, or a rotary mat or conveyor belt, and in general, anything which can support a flow of bodies in one or more directions in both senses of movement.

The detection of bodies passing through a gap has various uses. It is particularly applicable when the access of people or things to specific areas must be controlled. For example, in the case of people, it may be necessary to control their access to public transport means, such as the underground, or to public buildings or areas such as stadia or meeting places, or into shops or various public places.

One practical application may be, for example, to count the number of passengers getting on or off an urban service bus at each stop in order continuously to check the total number of passengers on the bus. In this way it is possible to avoid exceeding the maximum capacity of the bus, for example, by preventing further passengers getting on a bus which is already full. In addition, auxiliary procedures may be activated when the maximum capacity is reached, such as informing a service centre which can put additional buses in service to meet the public demand. Further subsidiary activities may result from the knowledge of the passenger data, such as statistical analyses based on the flow of passengers, or the derivation of information on possible deception by the passengers.

Currently, the automatic control of bodies passing through gaps is achieved with the use of various techniques, such as optical transmission and/or reflection barriers, for example, using light or infra-red radiation, or physical barriers such as turnstiles, pressure-sensitive platforms, or movement detectors based on micro-waves, passive infrared radiation or ultrasound.

It must, however, be borne in mind that there are many practical applications in which the use of physical barriers is not acceptable for safety reasons and/or in terms of practicality of use.

Furthermore, all the known systems have a number of limitations which make them unable to discriminate between objects and people, between objects and people that are very close together, or between objects and people moving in opposite directions or not perpendicular to the imaginary line of the gap. In addition, the known systems use sensors which may easily be tricked by objects or people moving at a steady speed.

An object of the invention is to provide a method for automatically detecting and counting bodies passing through a gap, which is simple and reliable and which enables the contemporaneous discrimination between their direction and sense of movement in order to check the flow into or out of at least one of the areas adjacent the gap.

This object is achieved by virtue of the fact that the method comprises the steps of:

- monitoring the gap with means for generating image signals in order to obtain a succession of images of each body passing through the gap, each image corresponding to a specific moment in time;
- processing these images to obtain an altimetric map of each body passing through the gap for each moment considered;
- comparing at least one altimetric map obtained with at least one model altimetric map stored in a processing unit; and
- depending on the result of the said comparison, activating a counting procedure.

By virtue of these characteristics, the method according to the invention enables bodies of different shapes to be discriminated between with a high degree of reliability, and the selection of solely a particular type of body for counting, for example, people only. In addition, the quantity of information that can be obtained by the method of the invention, which is significantly more than that which can be derived by the known techniques, enables more reliable and robust counting to be effected, overcoming the limitations which usually affect known systems, and thus providing greater adaptability to different working conditions and, therefore, greater generality of application.

It is therefore possible, with the invention, to discriminate between objects and people even when they are very close together, between objects and people moving in different directions or generally not perpendicular to the imaginary line of the gap, between objects and people moving at a steady speed or otherwise behaving in a way which could easily confuse the sensors used in known systems.

In particular, the term altimetric map is to be understood as any representation of the altimetric, or elevational, distortions caused by the presence of a body. One such map is obtained from the altimetric analysis of the body itself utilising known automatic methods which enable characteristics of the shape of the body to be described in a form which is easily comparable with similar maps of other bodies. If this analysis is conducted in correspondence with a gap, it is possible to distinguish between the bodies passing through it and, in the present case, to count just those which satisfy predetermined shape characteristics. Typically, in order to distinguish a person from other, differently-shaped bodies, one starts with the assumption that a person has a head

on top of a generally cylindrical trunk, conferring a characteristic altimetric profile thereon.

Naturally, a data processing system can be programmed in a known way to conduct an altimetric analysis of bodies with the aim of recognising the characteristic shape of people or other kinds of objects under consideration. Programming may be by means of conventional algorithmic approaches, the altimetric characteristics of the bodies to be recognised then being programmed into the processing system, or by means of statistical learning techniques like, for example, neural networks. In addition, a data processing system can be developed that is capable of evaluating the space-time evolution of the position of the bodies under consideration in order to deduce the dynamics of their movements, in particular, the direction and sense thereof.

A model of altimetric map of a body stored in the processing unit and utilisable for comparison with other altimetric maps obtained for bodies passing through the gap may be of the static type and thus formed on the basis of a single altimetric map referring to one moment in the traversal of the gap by a body, or it may be of the dynamic type and thus formed on the basis of a plurality of altimetric maps relating to a single body, each corresponding to a different moment in gap traversal.

A further subject of the invention is a device for automatically detecting and counting bodies passing through a gap, characterised in that it comprises:

- means for generating image signals relating to a gap;
- a processing unit connected to the image-signal-generator means for processing images arising therefrom in order to obtain altimetric maps of each body passing through the gap for successive moments, the processing unit also being capable of comparing at least one altimetric map obtained with at least one model altimetric map stored therein in order to activate at least one counting process depending on the result of the comparison.

Further characteristics and advantages of the present invention will become clearer from the following detailed description, given purely by way of non-limitative example and with reference to the accompanying drawings, in which:

- Figure 1 is a schematic perspective view showing a first embodiment of a device according to the invention;
- Figures 2a, 2b and 3 are, respectively, schematic illustrations of two views obtained by means of the device of Figure 1, and a stereoscopic view derived therefrom;
- Figure 4 is a view similar to Figure 1 of a further embodiment of a device according to the invention; and

- Figures 5 to 9 are views illustrating schematically the modes of operation of the device of Figure 4.

With reference to Figures 1 to 3, the reference numeral 1 generally indicates a device for automatically detecting and counting bodies passing through a gap. In particular, the device 1 is intended for obtaining the altimetric map of a body B which passes close to it, in this particular case below it, following to the composition of its stereoscopic image.

More specifically, the device 1 includes a pair of television cameras 3, conveniently of the low-resolution type, spaced from each other and preferably on the vertical of the gap to be checked. This gap is defined by an imaginary surface which is, for example, flat and vertical, capable of being traversed by moving bodies B, and defined at the base by a threshold line A which constitutes the projection on the ground of the imaginary surface.

Each television camera 3 takes an elementary image 4a, 4b at a specific moment, as shown in Figures 2a and 2b respectively. The two elementary images 4a and 4b obtained simultaneously by the two television cameras 3 are processed by a processing unit 5 which combines them to derive a single stereoscopic image 4, shown schematically in Figure 3 by a group of contour lines forming an altimetric map of the body B. The processing carried out by the unit 5 is such as to obtain a real world correspondence between the projections of the points of each elementary image to enable information relating to the disparity, namely, the distance between different positions of a single point on the two corresponding elementary images 4a and 4b, to be deduced. With the elementary images 4a and 4b taken simultaneously by each television camera 3 and the arrangement of the television cameras 3 with respect to the gap all being known, the three-dimensional spatial positions of all the points observed can be determined unequivocally. It is therefore possible to obtain a moment-by-moment altimetric, or elevational, map of the gap and the bodies B passing through it. As a result of a comparison of this altimetric map and its evolution over time with models known to the processing unit 5, it is easy to deduce whether a body B which passes through the gap satisfies predetermined conditions, for example, the fact that it has a head on top of a trunk in the case of a person, and is therefore to be counted. As discussed above, the models of altimetric maps already stored in the processing unit for the purpose of comparison may be based on a single moment in the traversal of the gap by the body B, thus being of the static type, and/or they may each be constituted by a plurality of altimetric maps of a single body corresponding to different moments in the traversal of the gap and may therefore be of the dynamic type.

From the mutual comparison of altimetric maps corresponding to a single body obtained at successive moments, it is also possible to deduce the direction and

sense of movement of each body B. In this way, it is possible to count a body B in a different way or to decide whether to count it or not depending on its sense of movement with respect to the threshold line A.

According to a further embodiment, and with reference to Figures 4 to 9, a device 7 according to the invention uses the so-called "structured light" technique which utilises particular characteristics of light to obtain information relating to the geometry of a scene.

In this case, the device 7 includes a single television camera 4 and a monochromatic light source 9 constituted, for example, by a solid state laser with an associated optic, which projects a plane of light coincident with the imaginary surface defining the gap. In this way, each body B passing through the gap breaks the plane of light and, as a result of its intersection therewith, causes luminous contour lines L to be generated on the edges of the body B, each of which, being illuminated by the plane of light, corresponds to an instantaneous, two-dimensional image of part of the contour of a section through the body B (see Figures 4, 5 and 7).

The television camera 4 is preferably positioned with its optical axis incident on the plane of light emitted by the source 9 and so that the entirety of the gap to be checked is covered to enable the detection of all parts of the scene illuminated by the intersection with the plane of light. The instantaneous two-dimensional image L of part of the contour of a body B (see Figure 8) transversing the surface constituting the gap, and defined by the plane of light, is composed of a plurality of points, each of which identifies a line of view in the three-dimensional space, which line extends from the respective point in the space to its projection on the image plane passing through the focus of the television camera 4. The three-dimensional position of each point on the luminous line L may then be obtained from a calculation of the position of the intersection of the line of view with the plane of light, the position of the plane of light being known as it is defined by the position of the source 9, and eventually determinable by direct measurement, as is the spatial position of the television camera 4 and its focal axis.

Only those surfaces of a body B that are substantially parallel to the plane of light are of uncertain detection by this technique, but this disadvantage can be overcome by the choice of an appropriate arrangement of the television camera 4 with respect to the light source 9.

The television camera 4 may, to advantage, be provided with an optical filter set to the frequency of the monochromatic light source.

From an analysis of the group of luminous lines L_0, L_1, \dots, L_N (see Figure 9) generated at successive moments t_0, t_1, \dots, t_N by the intersection of the plane of light projected by the source 9 with the profile of a body B traversing it, sufficient information about the shape of the surface of the body itself can be obtained to form the altimetric map of the body B.

The altimetric map obtained for each body B pass-

ing through the gap, which corresponds to the shape of the body itself at a specific moment, may be coded as illustrated in Figure 6 by means of a band which represents the various zones of its profile at different heights given by various shades of grey. Each instantaneous altimetric map, and/or its evolution over time during the traversal of the gap, can then be compared with static or dynamic models of altimetric maps of other bodies, that is, based on a single altimetric map or on a plurality of altimetric maps relating to successive moments, similarly coded and already stored in the processing unit 5 in order to recognise those of the bodies B passing through the gap that are to be counted. In this way it is possible, for example, to discriminate between people and luggage passing through the doorway of a transport means. It is also possible to recognise the contemporaneous presence of several people in the same scene.

By considering the variation of the altimetric map of a body over time, the movement of the body through the gap can be reconstructed to enable the direction and sense of its movement to be deduced with the consequent evaluation of whether it is entering or exiting one of the areas adjacent the gap and the activation of a counting procedure provided by the system.

Claims

1. A method for automatically detecting and counting bodies passing through a gap, characterised that in it comprises the steps of:
 - monitoring the gap (A) with means for generating image signals (3; 4, 9) to obtain a succession of images (4a, 4b; L_0, L_1, \dots, L_N) of each body (B) passing through the gap (A), each image (4a, 4b; L_0, L_1, \dots, L_N) corresponding to a specific moment in time;
 - processing these images (4a, 4b; L_0, L_1, \dots, L_N) to obtain an altimetric map of each body (B) passing through the gap (A) for each moment considered;
 - comparing at least one altimetric map obtained with at least one models of altimetric map stored in the processing unit (5); and
 - activating a counting procedure depending on the result of the said comparison.
2. A method according to Claim 1, characterised in that the models of altimetric maps include at least one altimetric map of a reference body corresponding to one moment in the traversal of the gap (A) by the respective body, and/or at least a plurality of altimetric maps of a reference body corresponding to different moments in the traversal of the gap (A) by that body.
3. A method according to Claim 1 or Claim 2, characterised in that the altimetric maps of a body (B)

obtained at different moments are compared with each other to determine the dynamics of the movement of the body (B) through the gap (A).

4. A method according to claim 3, characterised in that the counting procedure is activated in different ways depending on the dynamics of movement of each body (B) passing through the gap (A). 5
5. A method according to any of Claims 1 to 4, characterised in that the images (4a, 4b) obtained by the means for generating the image signals (3) are processed to obtain a stereoscopic image (4) of each body (B) passing through the gap (A). 10
6. A method according to any of Claims 1 to 4, characterised in that the means for generating the image signals (4, 9) are capable of obtaining two-dimensional images (L_0, L_1, \dots, L_N) containing altimetric information by the application of the structured light technique. 15 20
7. A device for automatically detecting and counting bodies passing through a gap, characterised in that it comprises: 25
 - means for generating image signals (3; 4, 9) associated with a gap (A); and a processing unit (5) connected to the image-signal-generator means (3; 4, 9) for processing images (4a, 4b; L_0, L_1, \dots, L_N) arising therefrom in order to obtain altimetric maps of each body (B) passing through the gap (A) for successive moments, the processing unit (5) also being capable of comparing at least one altimetric map obtained with at least one model altimetric map stored therein in order to activate at least one counting procedure depending on the result of the comparison. 30 35
8. A device according to Claim 7, characterised in that the processing unit (5) is capable of storing models of altimetric maps including at least one altimetric map of a reference body corresponding to one moment in the traversal of the gap (A) by that body, and/or at least a plurality of altimetric maps of a reference body corresponding to different moments in the traversal of the gap (A) by that body. 40 45
9. A device according to Claim 7 or Claim 8, characterised in that the image-signal-generator means comprise two television cameras (3) disposed with their respective focal axes spaced from each other, and in that the processing unit (5) is capable of handling a pair of images (4a, 4b) acquired by the said television cameras (3) at a single moment to form therefrom a stereoscopic image (4) of each body (B) passing through the gap (A) at that moment, 50 55
10. A device according to Claim 9, characterised in that the focal axes of the said television cameras (3) lie in an imaginary surface defining the gap (A).
11. A device according to Claim 7 or Claim 8, characterised in that the image-signal-generator means comprise a light source (9) capable of projecting a plane of light coincident with an imaginary surface defining the gap (A), and a television camera (4) disposed with its focal axis incident on this surface, and in that the processing unit (5) is capable of handling a plurality of two-dimensional images (L_0, L_1, \dots, L_N) acquired by the television camera (4), each corresponding to a different moment, in order to obtain an altimetric map of each body which passes through the gap (A).
12. A device according to Claim 11, characterised in that the light source (9) is a monochromatic light source, preferably a solid state laser.
13. A device according to Claim 12, characterised in that the television camera (4) has an optic provided with a filter set to the frequency of the light emitted by the light source (9).
14. A device according to Claim 10 or Claim 11, characterised in that the processing unit (5) is capable of comparing altimetric maps relating to successive moments for each body (B) passing through the gap (A), and of determining the direction and sense of movement of each body (B) through the gap (A).

and to obtain an associated altimetric map from this stereoscopic image (4).

FIG. 1

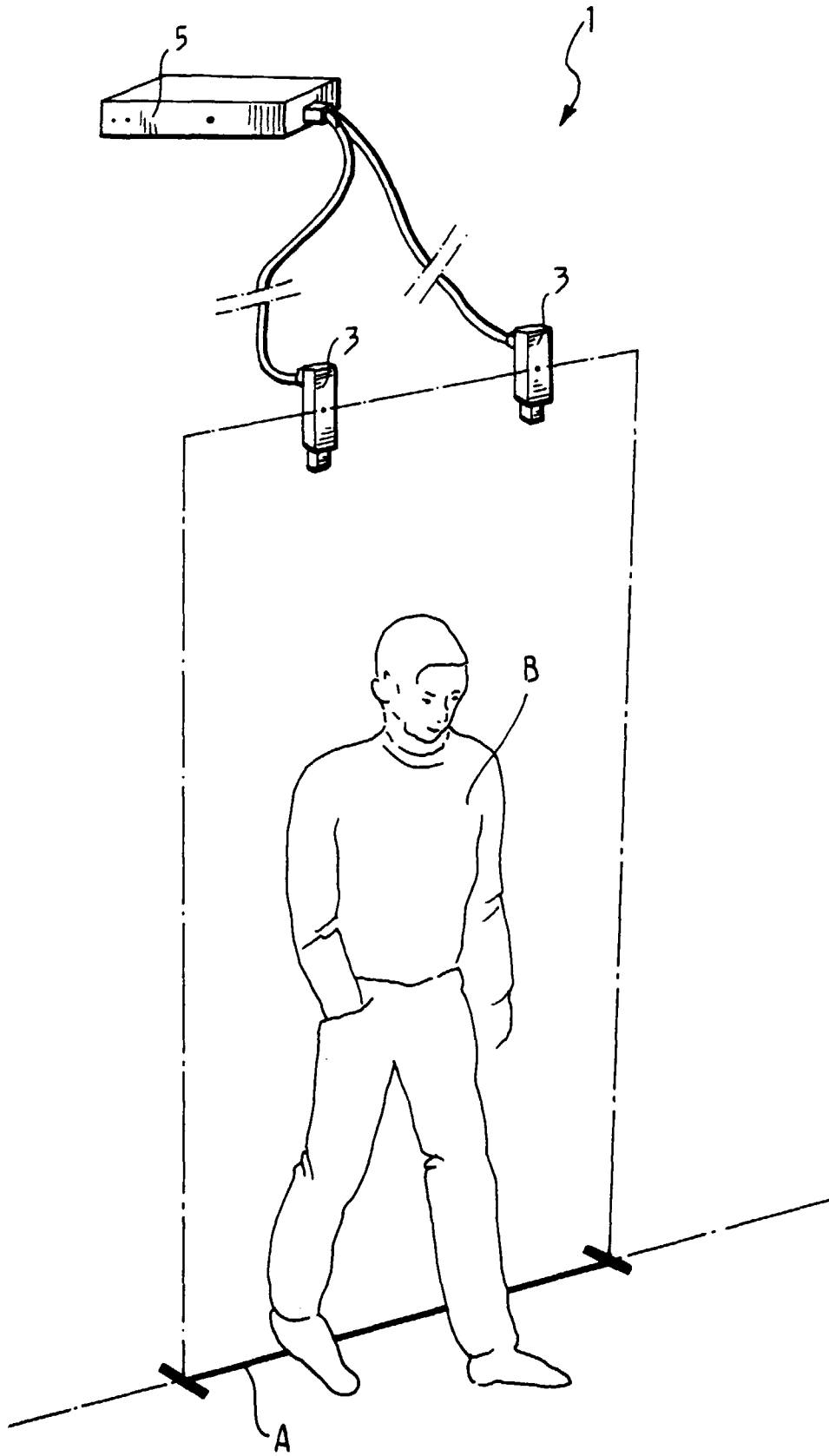

FIG. 2a

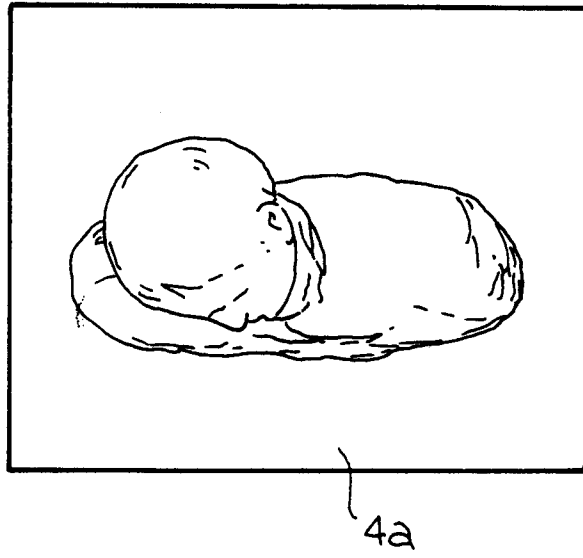

FIG. 2b

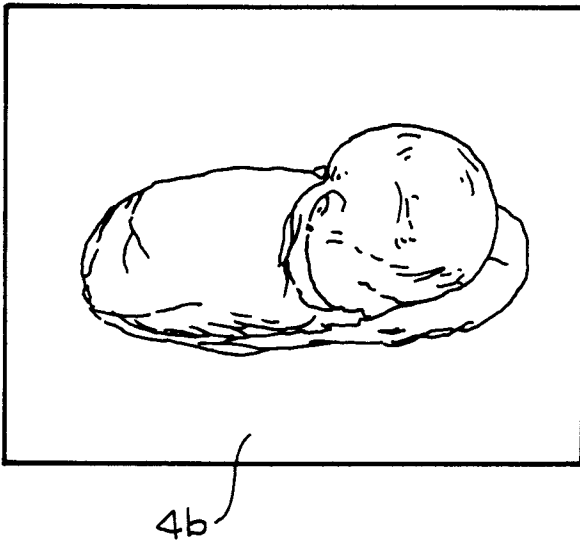
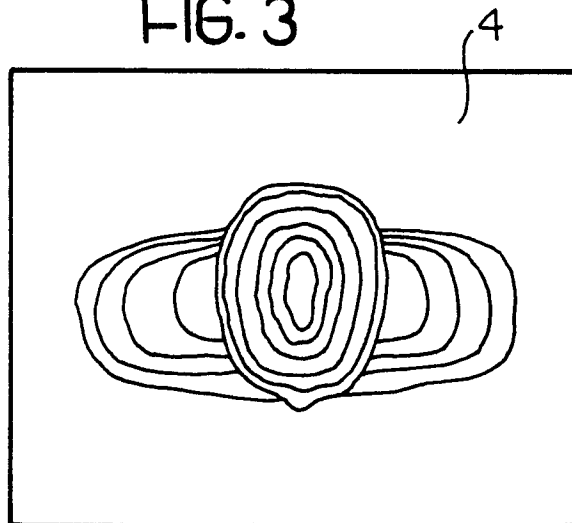

FIG. 3



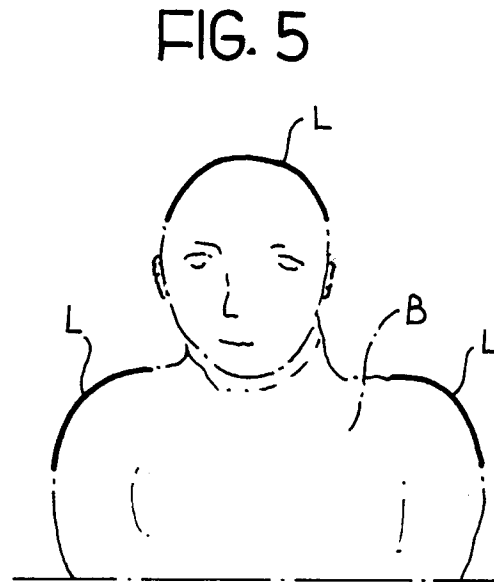
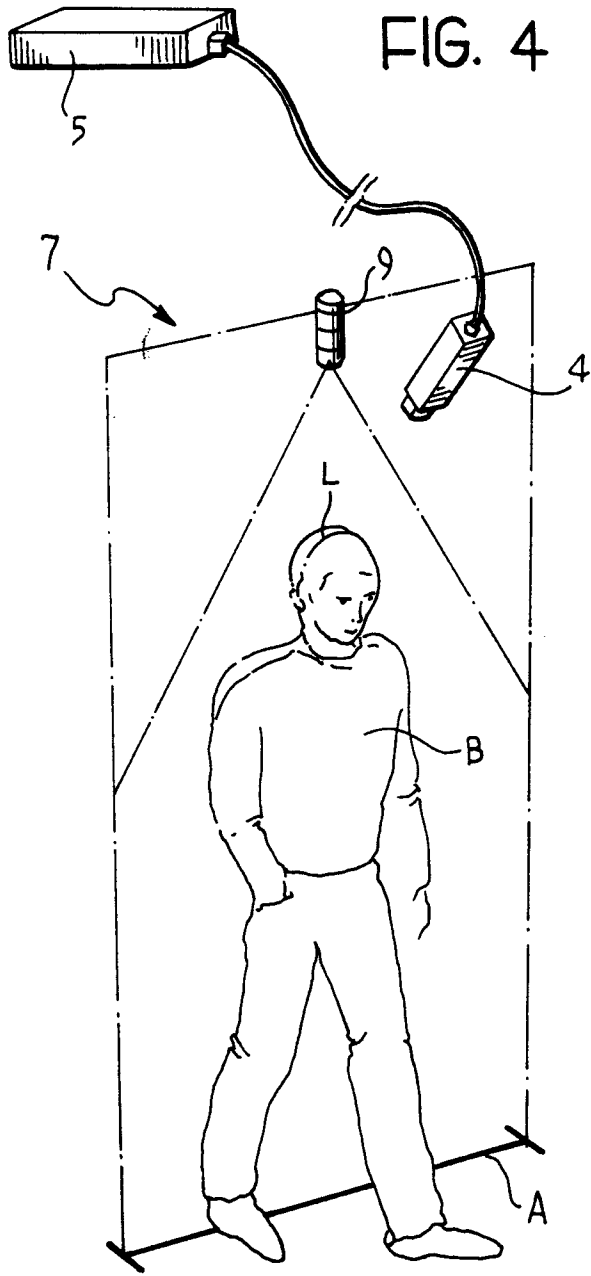

FIG. 6



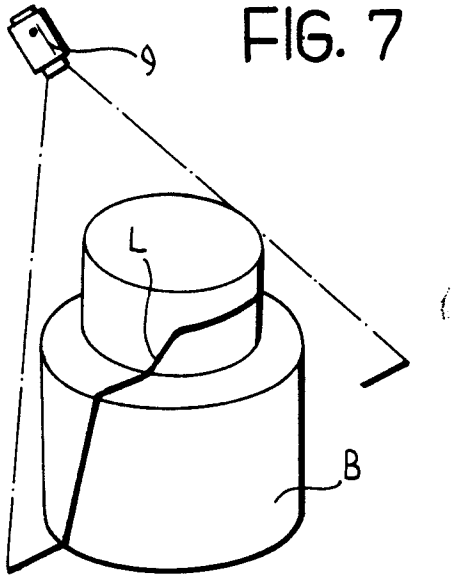

FIG. 8

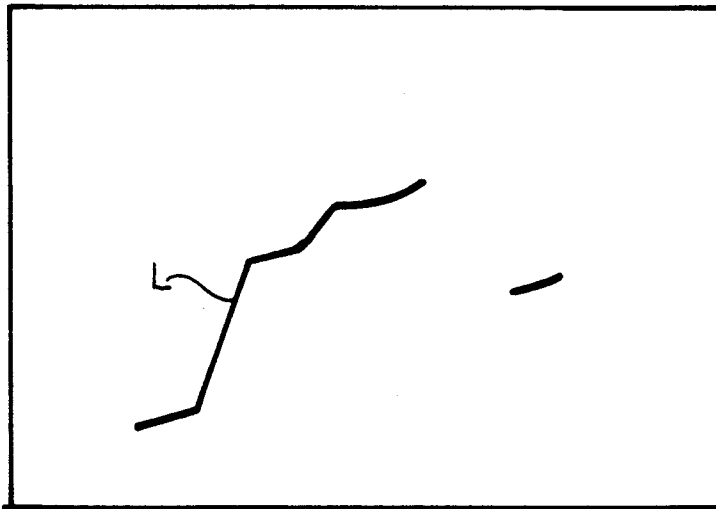

FIG. 9

