

(19)



Europäisches Patentamt
European Patent Office
Office européen des brevets



(11) **EP 0 855 363 A1**

(12)

EUROPEAN PATENT APPLICATION

(43) Date of publication:
29.07.1998 Bulletin 1998/31

(51) Int. Cl.⁶: **B67B 7/72**

(21) Application number: **97121274.1**

(22) Date of filing: **21.03.1995**

(84) Designated Contracting States:
**AT BE CH DE DK ES FR GB GR IE IT LI LU MC NL
PT SE**

(74) Representative: **Shaw, Laurence**
5th Floor,
Metropolitan House,
1 Hagley Road,
Edgbaston
Birmingham B16 8TG (GB)

(62) Document number(s) of the earlier application(s) in
accordance with Art. 76 EPC:
95912329.0 / 0 815 049

Remarks:
This application was filed on 14 - 12 - 1997 as a
divisional application to the application mentioned
under INID code 62.

(71) Applicant:
WILLIAM LEVENE LIMITED
Middlesex, HA2 7JP (GB)

(72) Inventor:
Pereira, Joseph Augustine Terence
Weybridge Surrey KT15 3NT (GB)

(54) **Can opener**

(57) The invention provides an improved can opener adapted to separate an end wall (E) from a can body (C) by cutting from the outside into the upstanding rim (R) formed at the end of the can, the rim (R) comprising overlapped portions (T, U) of the perimeter of the end wall (E) and the side wall (S) of the can, the can opener comprising two body portions (1, 3) arranged for relative pivotal movement about an axis, one body portion (3) carrying a rotary cutting wheel (7) and the other body portion (1) carrying a rotary traction wheel (12), the opener being arranged, in use, to receive the rim (R) of the can (C) between the two wheels (7, 12) and to orbit the can as the traction wheel (12) is rotated while the cutting wheel (7) makes a peripheral cut into the outside of the rim (R), the body portions (1, 3) carrying a pair of spaced abutments positioned to provide contact points (23, 24) on the rim when the rim is received between the two wheels, the contact points (23, 24) being located one on each side of the cutting point and in use exerting a downward force across the traction wheel (12) to counterbalance the upward force incurred during cutting and ensuring that the axis of the traction wheel (12) lies normal to the end wall (E) of the can.

EP 0 855 363 A1

Description

The invention relates to a can opener of the type which operates to separate an end wall or lid of the can by cutting from the outside into the upstanding rim formed at the end of the can and comprising overlapped portions of the perimeter of the end wall and the side wall of the can.

A can opener of this type is disclosed in European Patent publication EP-A-169224. That opener comprises two pivotally arranged body portions, one carrying a cutter wheel and the other a traction wheel, and the rim of the can to be opened is in use of the opener received between the wheels. The axes of the wheels are substantially parallel. A problem can arise with that opener in that even when the opener has cut around the entire periphery of the rim, it can still be difficult to remove the severed end wall. It is proposed in that disclosure to provide means separate from the cutter wheel to detach the severed end wall. For this purpose the opener, in one embodiment, includes an extra release hook, and in another embodiment, a lever which distorts the side wall of the can.

In our International patent application WO 92/02445, we have shown that by appropriate shaping of the parts supporting the rim of the can, the end wall can be cut so that it may be easily detached from the can.

Accordingly, in WO 92/02445 there is provided a can opener adapted to separate an end wall from a can body by cutting from the outside into the upstanding rim formed at the end of the can, the rim comprising overlapped portions of the perimeter of the end wall and the side wall of the can, the can opener comprising two body portions arranged for relative pivotal movement about an axis, one portion carrying a rotary cutting wheel and the other portion carrying a rotary traction wheel, the axes of the wheels being substantially parallel to each other (and to the main axis of the can body when in position for cutting) in one vertical plane, the opener being arranged, in use, to receive the rim of the can between the two wheels and to orbit the can as the traction wheel is rotated while the cutting wheel makes a peripheral cut into the outside of the rim, the traction wheel being shaped to distort the rim while it is cut by the cutting wheel to loosen the overlapping engagement between the end wall and the side wall of the can.

Preferably, to distort the rim, the traction wheel includes a portion having a surface adapted to engage, in use, the inner side wall of the rim, the said surface being inclined at an angle greater than the angle of the inclination of the rim with respect to the vertical axis of the can.

We have now found that further improvement in the separation of the overlapping engagement of the end wall and the side wall of the can can be achieved, for example, by a modification of the shape of the cutter wheel of the can opener disclosed in WO 92/02445.

Accordingly, in one aspect the invention provides a can opener adapted to separate an end wall from a can body by cutting from the outside into the upstanding rim formed at the end of the can, the rim comprising overlapped portions of the perimeter of the end wall and the side wall of the can, the can opener comprising two body portions arranged for relative pivotal movement about an axis, one body portion carrying a rotary cutting wheel and the other body portion carrying a rotary traction wheel, the opener being arranged, in use, to receive the rim of the can between the two wheels and to orbit the can as the traction wheel is rotated while the cutting wheel makes a peripheral cut into the outside of the rim, the body portions carrying a pair of spaced abutments positioned to provide contact points on the rim when the rim is received between the two wheels, the contact points being located one on each side of the cutting point and in use exerting a downward force across the traction wheel to counterbalance the upward force incurred during cutting and ensuring that the axis of the traction wheel lies normal to the end wall of the can.

The invention provides in another aspect a can opener cutting wheel to be used to separate an end wall from a can body by cutting from the outside in into the upstanding rim formed at the end of a can, said cutting wheel being adapted for rotation about its axis in cooperation with a traction wheel in the can opener, said cutting wheel comprising a body having an annular cutting edge, a portion of the body below said cutting edge having a wall sloping outwardly and downwardly relative to said axis and away from said cutting edge, the sloping wall being adapted to abut the rim below the level at which the cutting wheel cuts a peripheral cut into the rim.

By means of these contacts in the first aspect above the can is held in a stable position with its main axis substantially parallel to said axes of the wheels.

Although the axes of the wheels are substantially parallel in one vertical plane, the cutting head of the cutting wheel may be angled to lie at an angle, preferably of 5 to 12°, to the axis of the traction wheel and the can body in a second vertical plane.

By this means, the metal of the rim after the cut made by the cutter wheel is encouraged to separate.

Preferably, the angled body portion in the second aspect extends around the entire perimeter of the cutting wheel.

In an especially preferred embodiment, the angled body portion ends at its lower end in a flange or shoulder around the wheel, the outer face of the flange being aligned to extend substantially parallel with the longitudinal axis of rotation of the cutting wheel. By appropriate dimensioning of the flange relative to the cutting edge of the wheel, this outer face can abut the side of a can beneath its rim during the cutting operation to stabilise the can.

The traction wheel may also be shaped to distort the rim while it is cut by the cutting wheel to loosen the

overlapping engagement between the end wall and the side wall of the can. Preferably, to distort the rim, the traction wheel includes a portion having a surface adapted to engage, in use, the inner side wall of the rim, the said surface being inclined at an angle greater than the angle of the inclination of the rim with respect to the vertical axis of the can.

Preferably, rotation of the traction wheel causes passive rotation of the cutter wheel.

By means of the shaping of the cutter wheel below the cutting perimeter, the can also be more firmly maintained in the desired relationship without tendency for unwanted rotation or pivoting. The cutting wheel obtains a better bias against the can against the more rigid rim that it would against the thinner wall of the can body.

Embodiments of the invention will now be described by way of example, with reference to the accompanying diagrammatic drawings in which:

Figure 1 is an underneath plan view of one embodiment of a can opener embodying the invention;

Figure 2 is a cross-sectional view along line X - X of Figure 1;

Figure 3 is a view to an enlarged scale of part of Figure 2, but also showing a can rim in the cutting position and showing the cutting wheel of the invention in greater detail.

Figure 4 is a diagrammatic illustration in plan view of a portion of the embodiment shown in Figure 1;

Figure 5 is a part-sectional view along line Y - Y of Figure 2; and

Figure 6a is a partial sectional view showing a can rim before, and Figure 6b is the same view after cutting using the can opener of Figures 1 to 5.

The can C to be opened, as best seen in Figure 6a, includes a peripheral upstanding rim R, having an upwardly facing topmost portion T and a downwardly facing underside portion U. The rim R is formed from overlapped portions of the periphery of the end wall E of the can and the end portion of the side wall S of the can.

The can opener shown in the drawings is designed to be held in one hand of a user and comprises a first body portion 1 of relatively large size having a handle portion 2 and a second relatively smaller body portion 3 having a handle grip portion 4. The two body portions 1, 3 are separately moulded of plastics. A U-shaped recess in the underside of body portion 1 contains a die-cast metal insert 5 held in position by screws 6 into body 1. A spigot 5A extends from insert 5 through both body portions to join the body portions together in superimposed pivotal relation.

The two body portions of the can opener 1, 3 are

pivotaly movable relative to one another between a relatively closed condition, shown in the drawings, in which the handle 4 of body portion 3 lies flush against the handle 2 of the first portion 1 and a relatively open condition, not shown, in which the two handles are moved apart.

A cutter wheel 7 is rotatably mounted upon a bushing 9 within a recess 9A in the metal insert 5. The cutter wheel 7 includes an annular cutting body 10 which protrudes beyond the recess 9A, and a lowermost outwardly extending flange 11. The body 10 comprises two ramp portions 10a and 10b, Figure 3, which converge to define the cutting edge. The portions are asymmetrical, i.e. the topmost portion 10a is inclined at a very shallow angle, e.g. about 5 degrees to the horizontal plane, while the lowermost portion 10b is inclined at a relatively steeper angle of between about 45 degrees and 65 degrees to the horizontal plane, preferably about 55 degrees. Such an arrangement has been found to give a durable cutting edge which requires minimum force to make a cut. Above the portion 10a the cutter wheel includes a further inclined portion 7a to provide a clearance between the cutter and the traction wheel, to be described later on.

Below body portion 10, the cutting wheel has a body portion 10c that is angled to project outwardly as it gets further from the cutting edge. The angled body portion 10c is joined to the above-mentioned flange 11 by a shorter, less steeply angled body portion 10d.

Body portion 10c may be formed at an angle of, for example, from 5° to 20° to the longitudinal rotational axis of the cutting wheel and body portion 10d at an angle of, for example, from 25° to 35° to that axis.

Flange 11 has an outer circumferential face 11a that extends substantially parallel to the longitudinal axis of the cutting wheel.

A traction wheel 12 includes a pin 13 which extends through the body portion 1 at its end remote from its handle portion. The pin 13 rotates within a sleeve 14. A T-shaped handle 15 is secured to the top of the pin 13 for rotating the traction wheel 12 and a circlip and spring washer arrangement 16 is present in between the lowermost face of the handle 15 and the opposing face of the first body portion 1. The traction wheel 12 comprises an inverted frusto-conical portion 17, best seen in Figure 3.

The majority of cans currently available include a rim R having an inner face that diverges from the vertical axis of the can at an angle of about 8 to 10 degrees. We have discovered that by shaping the frusto-conical portion 17 of the traction wheel such that the rim R is bent or otherwise moved outwardly at an angle of greater than this angle during cutting, any remaining frictional engagement between the walls of the rim on each side of the cut is broken. The bending action will also tend to break any glue or like sealant present in the rim or, say, a plastics or like lining within the can. Accordingly, the angle of inclination of the portion 17 is

selected to be at least greater than about 10 degrees. The maximum angle of inclination should be less than that which so bends the rim that it makes the traction wheel difficult to turn, which is of especial importance where the can opener is of the hand operated variety.

The frusto-conical portion 17 includes ribs 18 to provide grip.

Referring now to Figures 4 and 5, the underside of body portion 1 is provided with an abutment plate 20 of generally U-shape in plan, the central region 21 of the U- being recessed and apertured to receive the above-mentioned pin 13. Traction wheel 12 is thereby provided centrally of the 'U' and projecting a little below the lowermost plane of the 'U'.

As shown in Figure 4, cutting wheel 7 lies partly within the open arms of the 'U' when the body portions are in the closed position and a gap d-d is provided between the two wheels to receive the rim R of a can.

Abutment plate 20, as shown in Figure 5, defines two opposed end regions 22 being the ends of the arms of the 'U'. When a can is inserted with its rim R between traction wheel 12 and cutting wheel 7 ends 22 rest on top of the can at contact points 23 and 24 and ensure that the axis of the traction wheel is normal to the lid or end E of the can. Downward pressure by these contact points straddling the cutting point is thereby provided across the traction wheel, this being shown as reaction force $F/2$ at each contact point to counterbalance upward force F incurred during cutting.

However, it will be appreciated that, due to the curvature of the can, there will be a tendency for the can to tilt as shown in Figure 4, arrow A, because of the offset d-d between forces F and $F/2$. Angled face 10C of the cutting wheel abuts the rim of the can to prevent this causing unwanted movement. As the abutment is against the rim rather than the thin wall of the can, this movement can be opposed without distortion of the can. By preventing the can from tilting, the rim is held in a stabilised position so that the cutting edge 10 can cut at the correct level from the top of the rim.

As shown, the longitudinal or rotational axis of the cutter wheel is inclined at an angle 'D' of about 8° to that of the traction wheel and the can body.

In use, the user initially moves the body portions to the open condition and introduces the rim R of the can C into the space between the traction and cutter wheels, i.e. cutter gap d-d (Figure 3), and then the two body portions are moved in scissors-like fashion towards the closed condition shown in the drawings.

As the body portions are further moved to the fully closed condition, the cutting edge 10 contacts and then cuts into an upper portion of the outside of the rim R, which is supported on its inner face by the frusto-conical portion 17, while the outside of the rim R is engaged by angled body portion 10c below the cut and urged inwardly thereby (Figure 3). The meeting of the handle portions provides a lock against excess force being applied to the rim and maintains the horizontal spacing

between the traction and cutter wheels at a substantially fixed distance.

As the traction wheel 12 is rotated it drives the passive cutting wheel and, because of the angle 'D', the cutting edge 10 make a spiral cut which extends vertically downwardly into the rim until the topside T of the rim is lifted away from the lower half of R by body portion 10a. The cutting wheel will then continue the rest of the cut, but will remain substantially parallel to the top of the rim with the cutting edge 10 tending to separate the cut edges of the end wall E and the side wall S in the manner of an agricultural ploughshare. The frusto-conical portion 17, in cooperation with the cutting edge 10, exerts a component of force outwardly and downwardly into the rim thereby to distort or bend the rim R while the opposite force applied by surface 10c enhances the separation effect on the cut rim. Thus the combined forces effectively hold the rim of the can in a stabilised position so that the cutting edge 10 can cut through the outer skin of R and lift the cut portion T. The opener is then removed from the can and the lid is simply pulled off by hand leaving smooth edges.

A comparison of the can rim before and after opening is shown in Figures 6a and 6b. As shown clearly in Figure 6b, after cutting the rim has been distorted just sufficiently that the end wall E may be simply lifted from the can body by simple hand operation and without the necessity for extra tool parts.

Claims

1. A can opener adapted to separate an end wall (E) from a can body (C) by cutting from the outside into the upstanding rim (R) formed at the end of the can, the rim (R) comprising overlapped portions (T, U) of the perimeter of the end wall (E) and the side wall (S) of the can, the can opener comprising two body portions (1, 3) arranged for relative pivotal movement about an axis, one body portion (3) carrying a rotary cutting wheel (7) and the other body portion (1) carrying a rotary traction wheel (12), the opener being arranged, in use, to receive the rim (R) of the can (C) between the two wheels (7, 12) and to orbit the can as the traction wheel (12) is rotated while the cutting wheel (7) makes a peripheral cut into the outside of the rim (R), the body portions (1, 3) carrying a pair of spaced abutments positioned to provide contact points (23, 24) on the rim when the rim is received between the two wheels, the contact points (23, 24) being located one on each side of the cutting point and in use exerting a downward force across the traction wheel (12) to counterbalance the upward force incurred during cutting and ensuring that the axis of the traction wheel (12) lies normal to end wall (E) of the can.
2. A can opener according to Claim 1, in which the abutments are provided one on each arm (22) of a

- 'U' shaped abutment plate (20) secured to the body portion carrying the traction wheel (12) and the plate (20) is bent away from the body portion to provide the contact points (23, 24) which are spaced substantially equidistantly from the traction wheel (12). 5
3. A can opener according to Claim 1 or 2, in which the traction wheel (12) is shaped to distort the rim (R) cut by the cutting wheel to loosen the overlapping engagement between the end wall (E) and the side wall (S) of the can. 10
 4. A can opener according to Claim 1, 2 or 3, in which the traction wheel (12) includes a portion having a surface (17) adapted to engage, in use, the inner side wall of the rim (R), the surface (17) being inclined at an angle greater than the angle of inclination of the rim (R) with respect to the vertical axis of the can (C). 15 20
 5. A can opener according to any preceding claim, in which the cutting wheel (7) has an outwardly angled body portion (10d) adjacent its cutting tip, the angled body portion (10d) being adapted to contact the rim (R) below the cut and thereby exerting a force on the rim (R) in a generally opposite direction to that of the traction wheel (12). 25
 6. A can opener according to any preceding claim, in which the cutting head (10) of the cutting wheel (7) lies at an angle to the axis of the traction wheel (12) and the can body in a vertical plane. 30
 7. A can opener according to claim 6, in which the angle is from 5° to 12°. 35
 8. A can opener according to Claim 5, in which the angled body portion (10d) extends around the entire perimeter of the cutting wheel (7). 40
 9. A can opener according to Claim 5 or 8, in which the angled body portion (10d) ends at its lower end in a flange or shoulder (11) around the wheel, the outer face (11a) of the flange or shoulder (11) being aligned in use to extend substantially parallel with the longitudinal axis of rotation of the cutting wheel (7). 45
 10. A can opener according to any one of Claims 2 to 10, in which the cutting wheel (7), in use, lies partly within the open arms (22) of the 'U' of the abutment plate (20). 50
 11. A can opener according to any preceding claim, in which the cutting wheel (7) has an annular cutting body (10) comprising two ramp portions (10a, 10b) which converge to define the cutting edge, the portions being asymmetrical. 55
12. A can opener according to Claim 11, in which the lower ramp portion (10b) is inclined at between 45° and 65° to the horizontal plane and the upper ramp portion (10a) is inclined at a shallower angle to the horizontal plane.
 13. A can opener cutting wheel to be used to separate an end wall (E) from a can body (C) by cutting from the outside in into the upstanding rim (R) formed at the end of a can (C), said cutting wheel (7) being adapted for rotation about its axis in co-operation with a traction wheel (12) in the can opener, said cutting wheel (7) comprising a body (10) having an annular cutting edge (10a, 10b), a portion of the body below said cutting edge having a wall (10d) sloping outwardly and downwardly relative to said axis and away from said cutting edge, the sloping wall (10d) being adapted to abut the rim (R) below the level at which the cutting wheel (7) cuts a peripheral cut into the rim (R).
 14. A cutting wheel according to Claim 13, in which the cutting wheel (7) has an angled body portion (10d) ends at the lower end in a flange or shoulder (11), the outer face (11a) of the flange or shoulder being aligned to extend substantially parallel with the longitudinal axis of rotation of the cutting wheel.
 15. A cutting wheel according to Claim 14, in which the angled body portion (10d) extends around the entire perimeter of the cutting wheel.
 16. A cutting wheel according to any one of Claims 13 to 15, in which the cutting wheel (7) has an annular cutting body comprising two ramp portions (10a, 10b) which converge to define the cutting edge, the portions being asymmetrical.
 17. A cutting wheel according to Claim 16, in which the lower ramp portion (10b) is inclined at between 45° to 65° to the horizontal plane and the upper ramp portion (10a) is inclined at a shallower angle to the horizontal plane.
 18. A can opener according to any one of Claims 13 to 17, in which the cutting head (10) of the cutting wheel (7) lies at an angle to the axis of the traction wheel (12) and the can body in a vertical plane.
 19. A can opener according to Claim 18, in which the angle is from 5° to 12°.

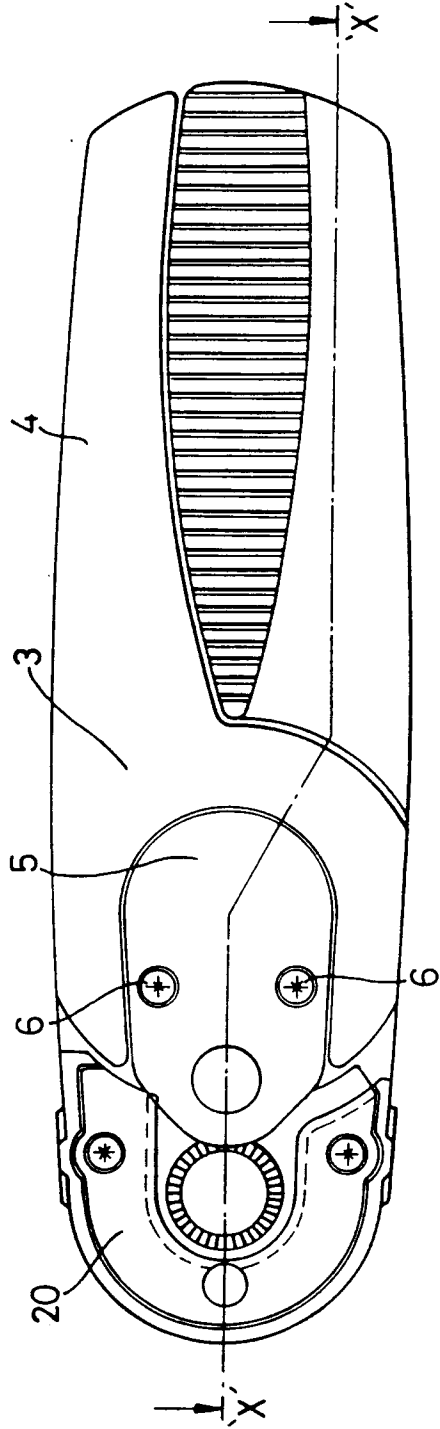

Fig. 1

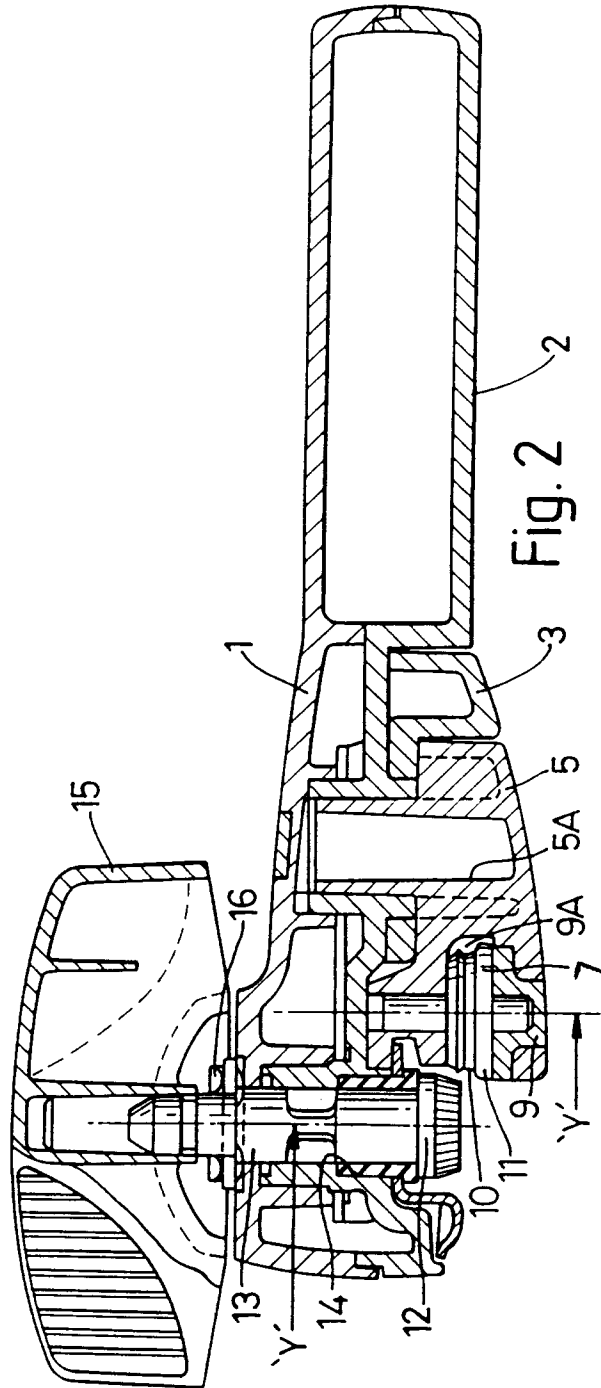

Fig. 2

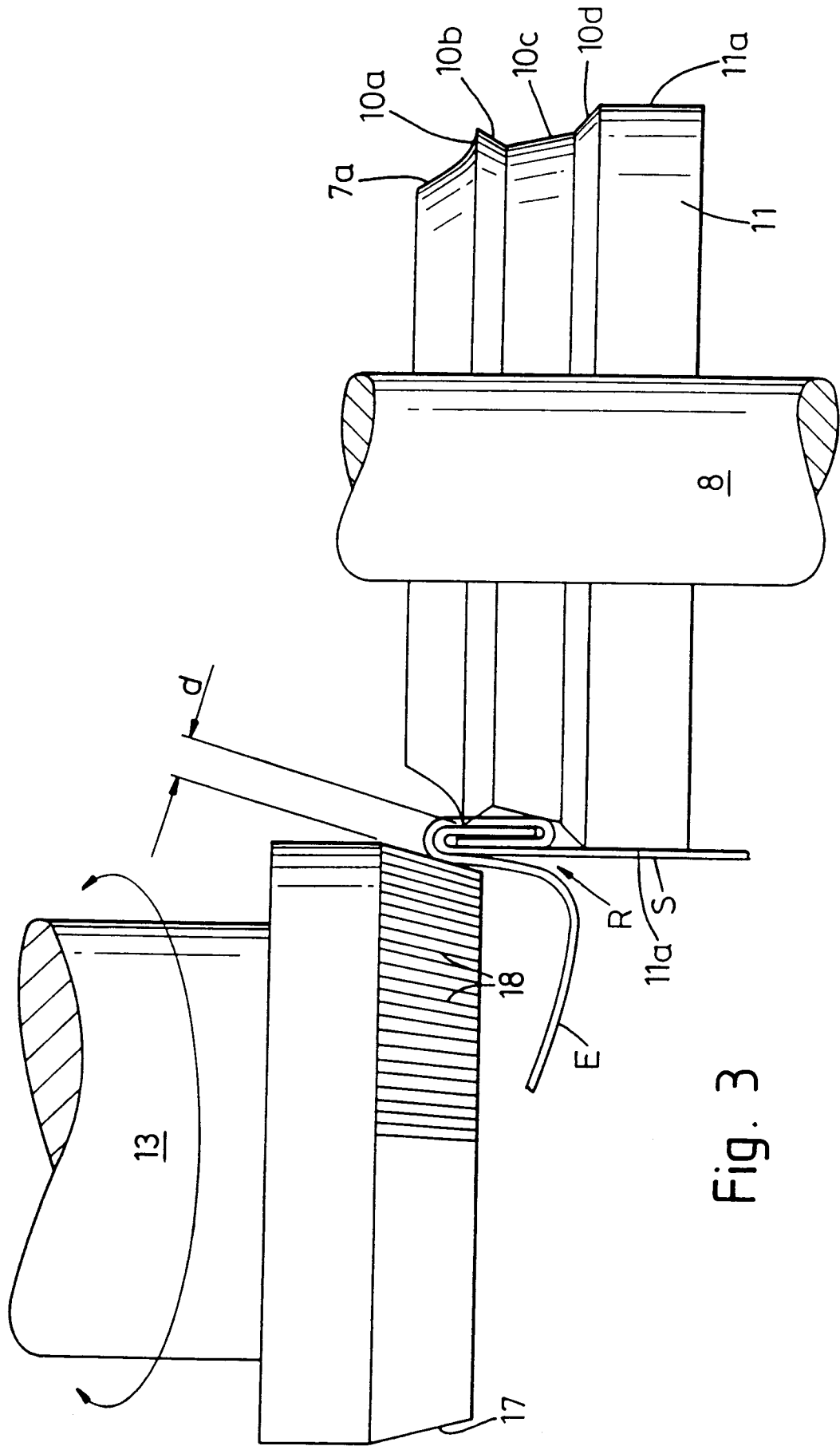

Fig. 3

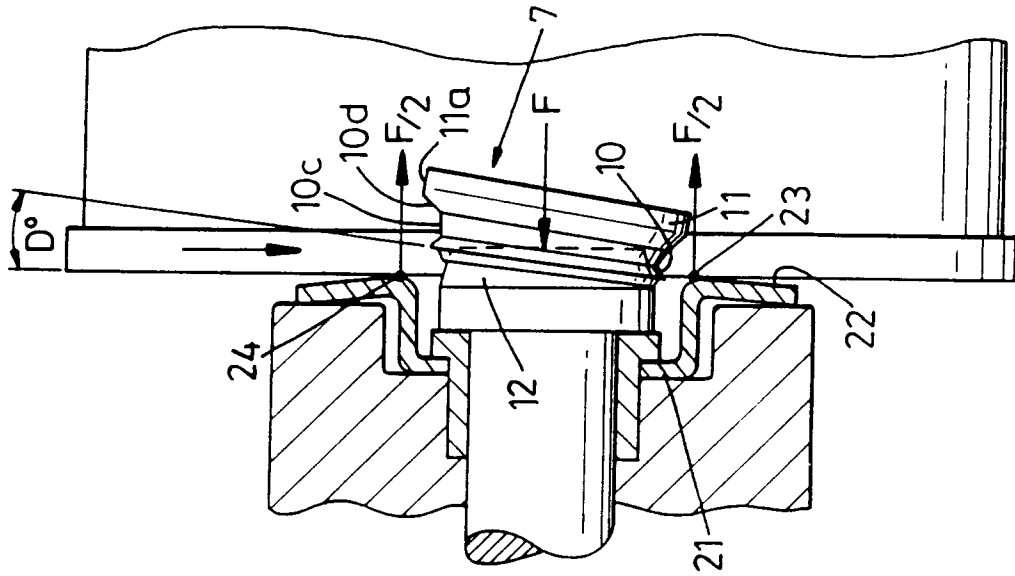

Fig. 5

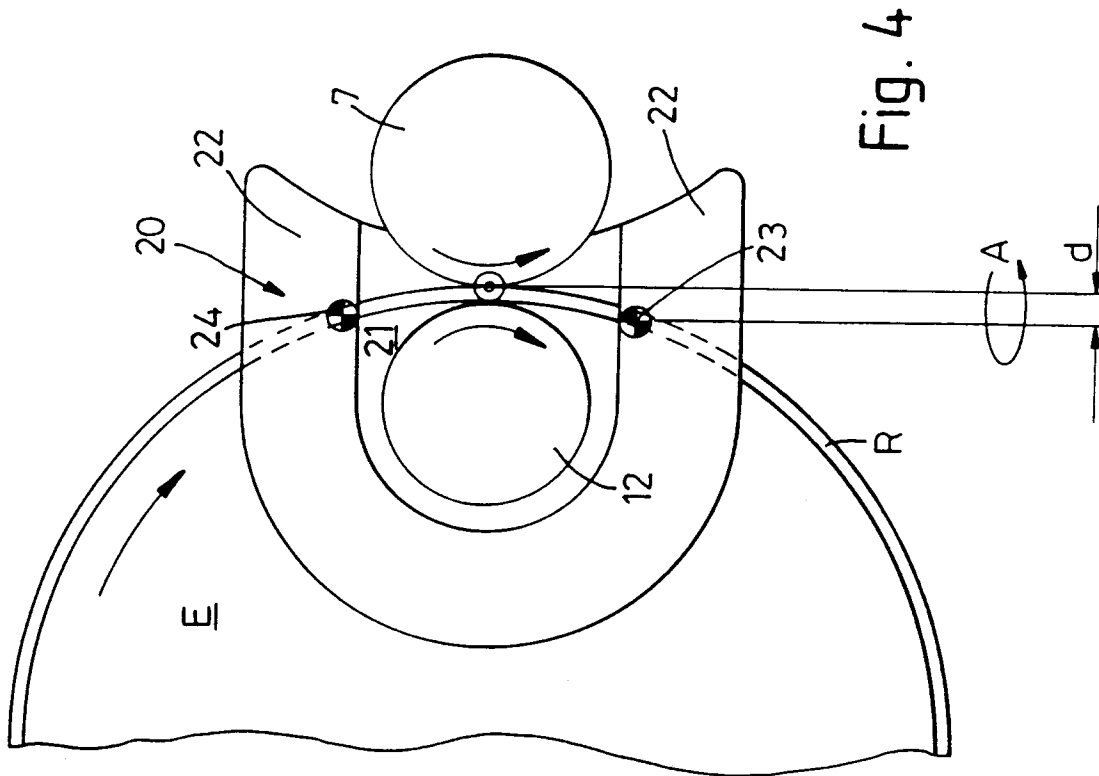
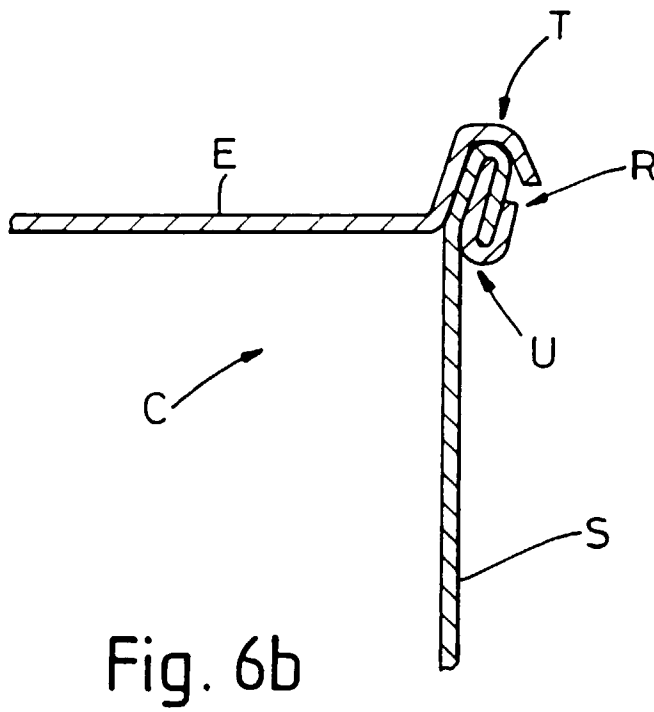
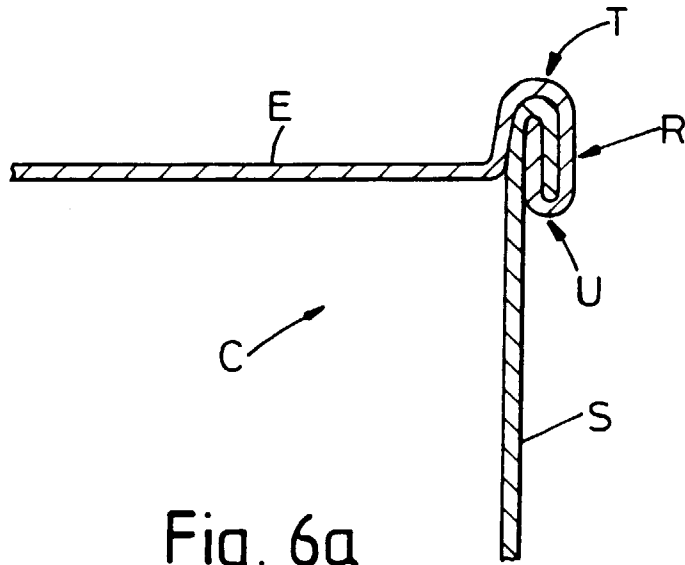

Fig. 4





European Patent
Office

EUROPEAN SEARCH REPORT

Application Number
EP 97 12 1274

DOCUMENTS CONSIDERED TO BE RELEVANT			
Category	Citation of document with indication, where appropriate, of relevant passages	Relevant to claim	CLASSIFICATION OF THE APPLICATION (Int.Cl.6)
X Y A	GB 1 027 624 A (V. DIXON) * page 1, line 87 - page 2, line 65 * * figures 1-5 * ---	1,3,6 5,7-12 2	B67B7/72
X Y	EP 0 575 016 A (IBL PRODUCTS COMPANY) 22 December 1993 * column 3, line 15 - column 5, line 44 * * figures 1,2,4-6 * ---	13-15 5,8-10, 16-19	
Y A	US 5 121 546 A (W. CHONG) 16 June 1992 * column 2, line 30 - column 4, line 21 * * figures 1-5 * ---	7,11,12, 16-19 1,3,6	
A	GB 1 140 518 A (SUNBEAM CORPORATION) * page 6, line 104 - page 7, line 92 * * figures 13-15 * ---	1,3,5,8, 11-17	
D,A	WO 92 02445 A (WILLIAM LEVENE LIMITED) 20 February 1992 * page 4, line 15 - page 11, line 3 * * figures 1-5,6A,6B * ---	1,3,4	TECHNICAL FIELDS SEARCHED (Int.Cl.6) B67B
E	GB 2 285 789 A (WILLIAM LEVENE LIMITED) 26 July 1995 * the whole document * -----	1-19	
The present search report has been drawn up for all claims			
Place of search THE HAGUE		Date of completion of the search 22 April 1998	Examiner Smolders, R
CATEGORY OF CITED DOCUMENTS X : particularly relevant if taken alone Y : particularly relevant if combined with another document of the same category A : technological background O : non-written disclosure P : intermediate document		T : theory or principle underlying the invention E : earlier patent document, but published on, or after the filing date D : document cited in the application L : document cited for other reasons & : member of the same patent family, corresponding document	

EPO FORM 1503 03.82 (P04C01)