

(19)



Europäisches Patentamt  
European Patent Office  
Office européen des brevets



(11)

**EP 0 857 415 A1**

(12)

**EUROPEAN PATENT APPLICATION**

(43) Date of publication:  
**12.08.1998 Bulletin 1998/33**

(51) Int Cl. 6: **A01G 1/00, A01G 9/02**

(21) Application number: **98300243.7**

(22) Date of filing: **14.01.1998**

(84) Designated Contracting States:  
**AT BE CH DE DK ES FI FR GB GR IE IT LI LU MC  
NL PT SE**  
Designated Extension States:  
**AL LT LV MK RO SI**

(72) Inventor: **Fukuzumi, Yutaka**  
**Yokohama-shi, Kanagawa-ken (JP)**

(74) Representative: **Whalley, Kevin**  
**MARKS & CLERK,**  
**57-60 Lincoln's Inn Fields**  
**London WC2A 3LS (GB)**

(30) Priority: **15.01.1997 JP 17834/97**

(71) Applicant: **Fukuzumi, Yutaka**  
**Yokohama-shi, Kanagawa-ken (JP)**

**(54) Method for planting trees in an inclined face**

(57) A method for planting trees (T) in an inclined face (G) comprises the steps of arranging a plurality of compartments (2) in a sandbag (1) made of a flexible material which the roots of trees can break through and providing each of said compartments (2) with windows (3); arranging soil (4) in said compartments (2); planting trees (T) through said windows (3) into said compart-

ments (2); arranging said sandbag (1), as completed of planting, in said inclined face (G) with the trunks of said trees (T) exposed through said windows (3); filling soil (10) between said sandbag (1) and said inclined face (G); and pressing said sandbag (1) onto said inclined face (G) by means of a fence (6) through which the trunks of said trees (T) can pass.

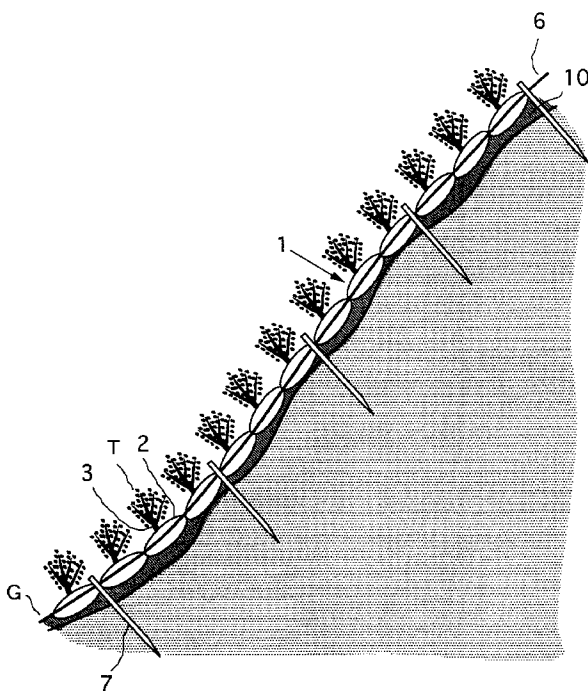

**FIG. 1**

**EP 0 857 415 A1**

## Description

The present invention relates to a method for enabling planting trees in an inclined face of soil difficult to fix trees therein.

When a mountain M is cut through for the purpose of, for example, quarrying or mining, an inclined face G is formed resultantly as shown in FIG. 8.

Naturally such an inclined face G has no trees therein and, therefore, is deficient in water-holding capacity, thus damaging the landscape and causing landslides and other disaster.

It is therefore desired to plant trees in such an inclined face and green it, for whose purpose actually a method is publicly known to plant trees.

Such an inclined face, however, is formed after a mountain is quarried or mined and naturally has stones and base rocks in the soil, so that it is extremely difficult to plant trees there.

Of course, a certain kind of trees represented by pine trees will overcome such soil of stones and base rocks and take root, to be implanted.

For those trees to take root, however, it takes a long time, so that they have to be fixed and grown in an inclined face for a long period of time.

The conventional methods would provide foreign soil in an inclined face to grow trees, which inflicts, however, a heavy burden in contrast to flat land. Moreover, such precious foreign soil may be lost by rainwater etc.

Also, if the layer of foreign soil is thin, trees may be lifted against a solid inclined face as the roots grow, so that the roots may not be implanted into the inclined face.

Moreover, if an inclined face is steep, e.g. about 70 degrees, it is very dangerous for workers to clime up the inclined face and plant trees, with special footholds required, thus causing problems both in safety and cost.

As inventions for cultivating trees by using sandbags are available U.S. Patent Nos. 5257476, 5579603, 4299056, 3667157 and 4918861, U.K. Patent Nos. 2152345, 2239155, and 2152345, and Japan Patent 8-246465, none of which is aimed at the above-mentioned applications though.

The object of the present invention is to provide a method for planting trees free from the above-mentioned problems peculiar to the prior art.

That is, a planting method according to the present invention comprises the steps of placing a plurality of compartments in a sandbag in its whole length direction and proving each of said compartments with windows in external communication, to make up said sandbag such as made with a flexible material which the roots of said trees can break through; containing soil into each of said compartments with said sandbag as laid horizontal; planting trees through said windows into each of said compartments; arranging said sandbag as completed of planting, in said inclined face with the trunks of said trees exposed through said windows; filling soil between

sandbag and said inclined face; and pressing said sandbag onto said inclined face by means of a fence which the stems or trunks of said trees can pass through.

Thus, trees will grow in the sandbags used as a soil floor, and then their roots will break them through and be implanted in the inclined face.

According to the planting method of the present invention, first of all it is possible to supply soil and plant trees in a sandbag as laid horizontal, thus enabling the work to be done not in a inclined face but on the horizontal ground.

Second, the structure of the sandbag can be made simple, because it is possible to supply soil, plant trees, and expose the trunks through the same windows.

Third, thus completed sandbag can be hoisted up with their trunks as exposed through the windows and then be distributed over the inclined face and fixed to complete planting, thus eliminating the necessity to arrange any particular footholds in the inclined face and at the same time reducing the labor by the workers on the inclined face to a minimum.

FIG. 1 is a cross-sectional view of an inclined face in which trees are planted according to a method of the present invention;

FIG. 2 is a perspective view of a member used in the present invention;

FIG. 3 is an expanded sectional view of an inclined face in which trees are planted according to an embodiment of the present invention;

FIG. 4 is an expanded sectional view of an inclined face in which trees are planted according to another embodiment of the present invention;

FIG. 5 is a cross-sectional view of an inclined face illustrating processes of a planting method of the present invention;

FIG. 6 is a cross-sectional view of an inclined face illustrating processes of another planting method of the present invention;

FIG. 7 is a cross-sectional view of an inclined face which is greened by a planting method of the present invention; and

FIG. 8 is a side view of an inclined face brought about by quarrying or mining.

The preferred embodiments of the present invention will be described below with reference to the accompanying drawings.

A reference numeral 1 refers to a sandbag arranged in an inclined face G.

The sandbag 1 must be made with at least an flexible material having such a strength that the roots of a tree T can break through it, as which material is assumed here a non-woven fabric sheet made of polyester, nylon, polyethylene, polypropylene, span bond, etc.

The sandbag 1 comprises therein a plurality of compartments 2, to contain soil, sequentially arranged in the direction of the whole length of the sandbag 1.

Although the sandbag 1 is assumed here to be completely closed like a bag, it must not necessarily be completely closed but may be a type of a bag opened at the end for example.

A reference numeral 3 refers to a window opened in the above-mentioned compartment, coming in a slit arranged along the whole length of the sandbag 1.

Although the window 3 is arranged on the basis of the number and the spacing of trees T distributed into each of the compartments 2, it may of course be given to each window or each number of windows of a further subdivided compartment 2, because of which the compartment wall is not shown.

The following will describe how to use the sandbag.

The sandbag 1 is first placed as laid horizontal, for example, on the horizontal ground.

Then, by flexing the compartments 2 of the sandbag 1 in a direction of the slits, the slit-shaped windows 3 are deformed into an large circular shape, through which soil 4 is supplied into each of the compartments.

Subsequently, into each compartment 2 containing the soil 4, the trees T are planted through the windows 3.

In this case, as the trees T, those trees cultivated by such a method as generally called "container cultivation" or "pot cultivation" are used.

That is, here the trees cultivated in a certain container are pulled out with soil 5 hardened along the internal geometry of the container as attached to the roots, and then used, thus realizing secure planting (see FIG. 3).

The soil 1 as completed of the above-mentioned work is hoisted up by a crane etc. to be arranged at a desired planting position, during which in the present embodiment the soil 1 is pulled by its own weight in a direction of its own whole length, so that the windows 3 are solidly closed in their original slit shape, thus preventing the soil 3 from leaking out.

The above-mentioned soil 1 will be fixed in the inclined face G, here by means of a fence.

As shown in FIG. 5, anchors 7 (which is assumed to measure 2 to 3 meters in length and be made of metal) are first buried in the inclined face G at a prescribed spacing.

Next, as shown in FIG. 6, the soil 1 completed of planting is hoisted up with a crane etc. and arranged in the inclined face G with the tree trunks as exposed through the windows.

The soil 1 thus arranged in the inclined surface G are, as shown in FIGS. 1 and 3, pressed onto the inclined surface by means of a fence 6, which is fixed to the anchors 7 at the same time.

The fence 6 must have therein at least through-holes which the trunks of the trees T can pass through, coming assumably in for example, a grid-shaped assembly of wires or a wire-netting (see FIG. 6).

Although the fence 6 is fixed to the anchors 7 protruded from the inclined surface G with for example a wire 8, it may of course be fixed with such hardware as

the wire 8 through which rings A or hooks provided at the head of the anchors 7 are pierced.

In the latter case, execution is easier and, moreover, the part of the anchors 7 which is protruded from the inclined face G will as a merit stay near its surface.

In the above-mentioned embodiment, the soil 10 is filled between the sandbag 1 and the inclined face G so that the trees T may take root well and also that the sandbag 1 may be adapted to the irregularities in the surfaces of the inclined face G.

The trees T as completed of the above-mentioned work are first grown in soil 2 in the sandbag 1 used as a soil floor and then, their roots would break through the sandbag 1 and grow on the soil 10, thus expanding as far as to the inclined face G.

Finally, the trees T are completely implanted in the inclined face G (see FIG. 7).

During the above-mentioned processes, the trunks T1 of the trees T expanding over the ground will of course pass through the through-holes of the fence 6.

The trees T, on the other hand, will assumably be given as many as about 8 through 10 per m<sup>2</sup> at around the start of execution but, eventually, be reduced to one or so per 3 m<sup>2</sup> by natural selection in a course of growing.

Also, the fence 6 will be kept as fixed for approximately 10 to 20 years until the roots of the trees T are locked together to provide a natural forest, in order to prevent the surface soil of the inclined face G from falling in.

The tree suited for the embodiments of the present invention may best come in for example Juniperus Chinensis, Juniperus Conferta, Euonymus Fortunei, Cotonaster, Cotoneaster Horizontal, Vitex Rotundifolia, etc., but in any kinds of trees as far as they can be planted generally, if the inclination angle of the inclined face is 60 degrees or less.

The present invention has the following inherent merits:

- (1) Trees can be planted on the horizontal ground and, after that, the concerned sandbag can be hoisted up and then arranged and fixed in an inclined face to complete execution, so that no planting work including drilling is necessary in the inclined face, thus enabling easy planting in any inclined faces having poor footholds.
- (2) Trees can be planted easily also when the inclined face comprises stones and base rocks.
- (3) Since trees are fixed in a sandbag, none of the trees may possibly be lost by rainwater etc., realizing secure planting.
- (4) Trees are first implanted into a sandbag used as a soil floor and, in the next process, their roots reach an inclined face, during which the sandbag in which the trees are already implanted is securely fixed to the inclined face with a fence, to prevent together with its own weight the trees from being lifted

against the inclined face as the roots grow and also not being implanted into the inclined face, thus realizing secure planting.

(5) With the present invention, inclined faces brought about by quarrying or mining can be greened easily, contributing to the protection of landscape and the flood control. 5

## Claims 10

1. A method for planting trees (T) in an inclined face (G), comprising the steps of:

arranging a plurality of compartments (2) in a sandbag (1) in its whole length direction and providing each of said compartments with windows (3) in external communication, said sandbag being made of a flexible material which the roots of trees can break through; 15 20

arranging soil (4) in each of said compartments (2) with said sandbag (1) as laid horizontal; planting trees (T) through said windows (3) into each of said compartments (2);

arranging said sandbag (1), as completed of planting, in said inclined face (G) with the trunks of said trees (T) exposed through said windows (3); 25

filling soil (10) between said sandbag (1) and said inclined face (G); 30

pressing said sandbag (1) onto said inclined face (G) by means of a fence (6) through which the trunks of said trees (T) can pass; and

growing said trees (T) using said sandbag (1) as a soil floor and then implanting in said inclined face (G) the roots of said trees which have broken through said sandbag. 35 40

40

45

50

55

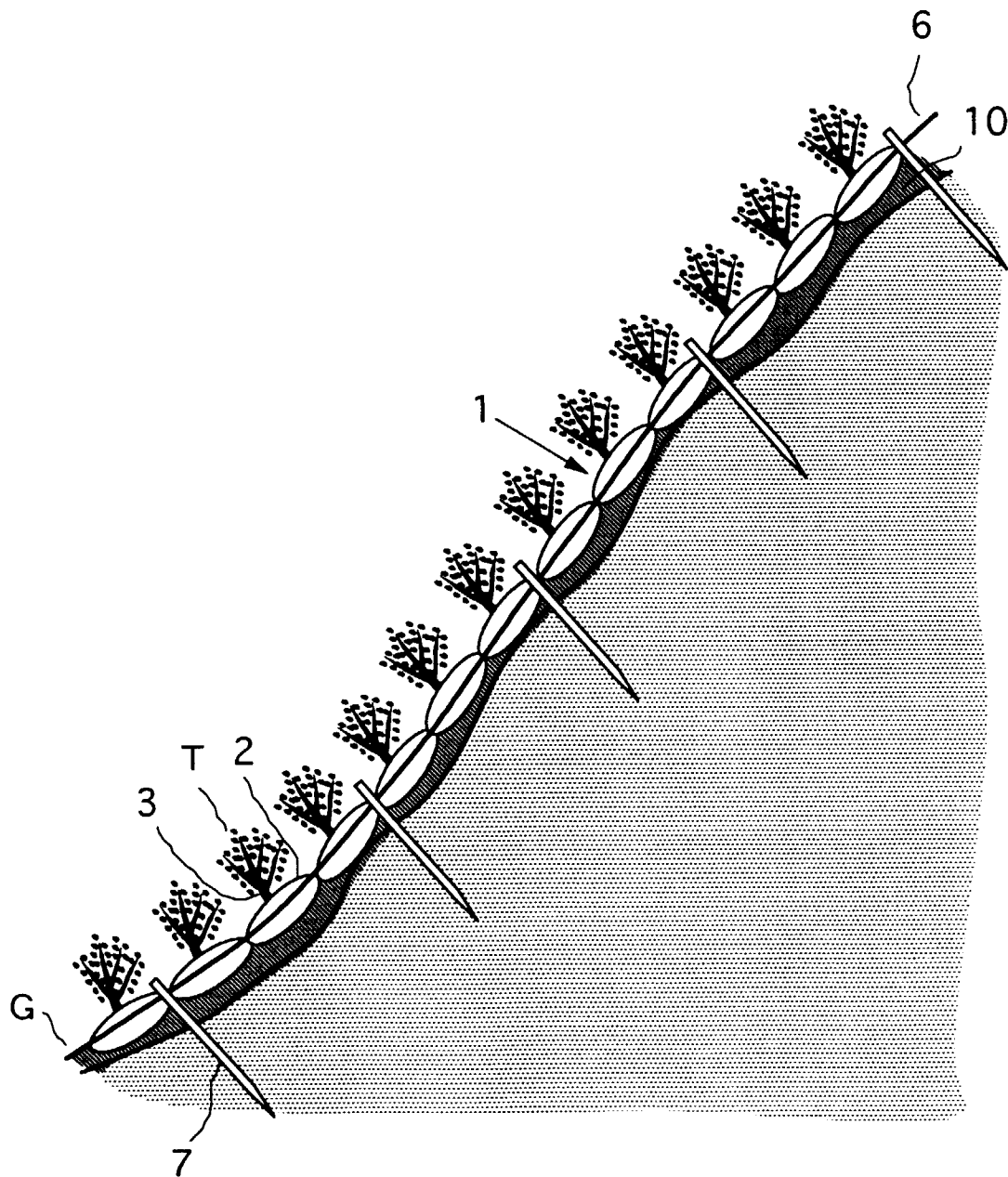

FIG. 1

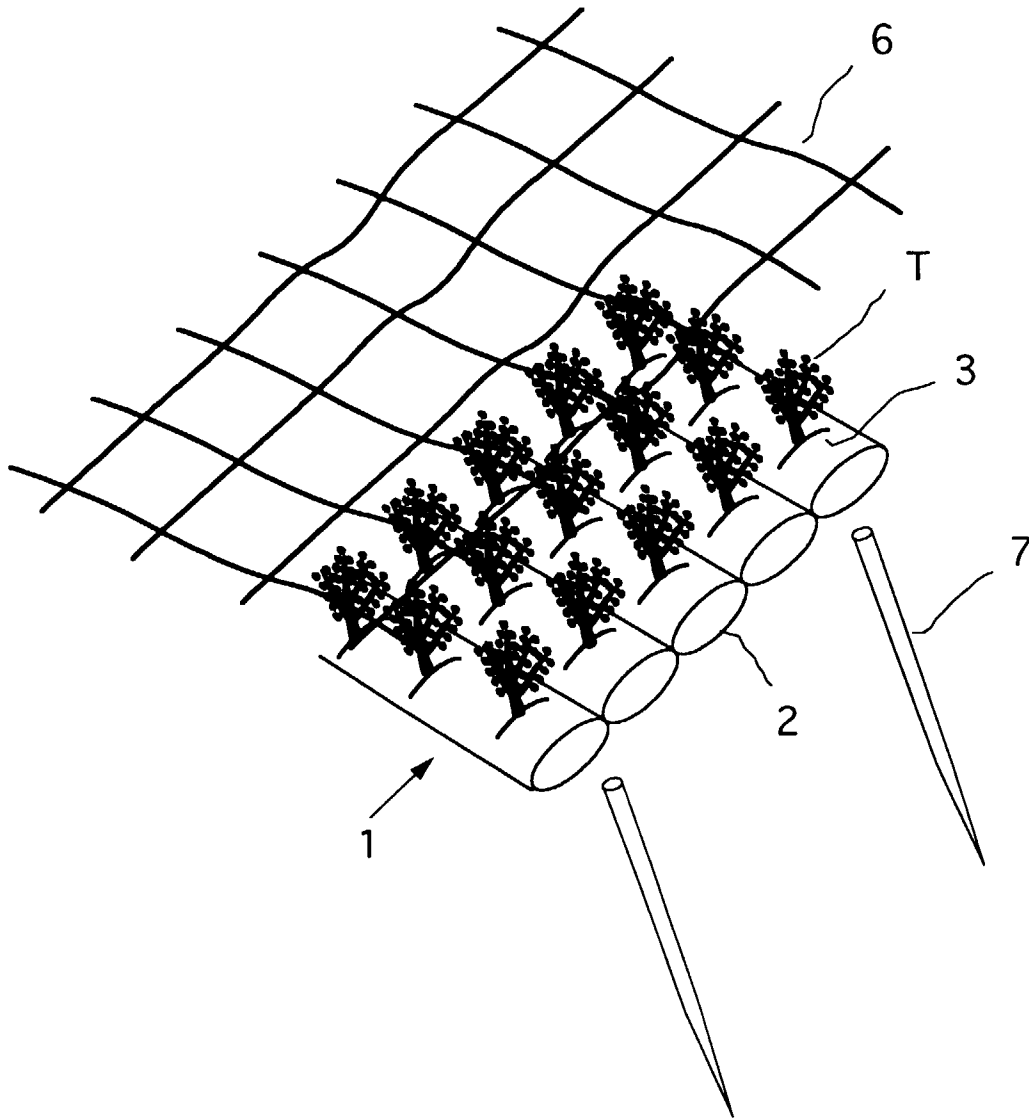

FIG. 2

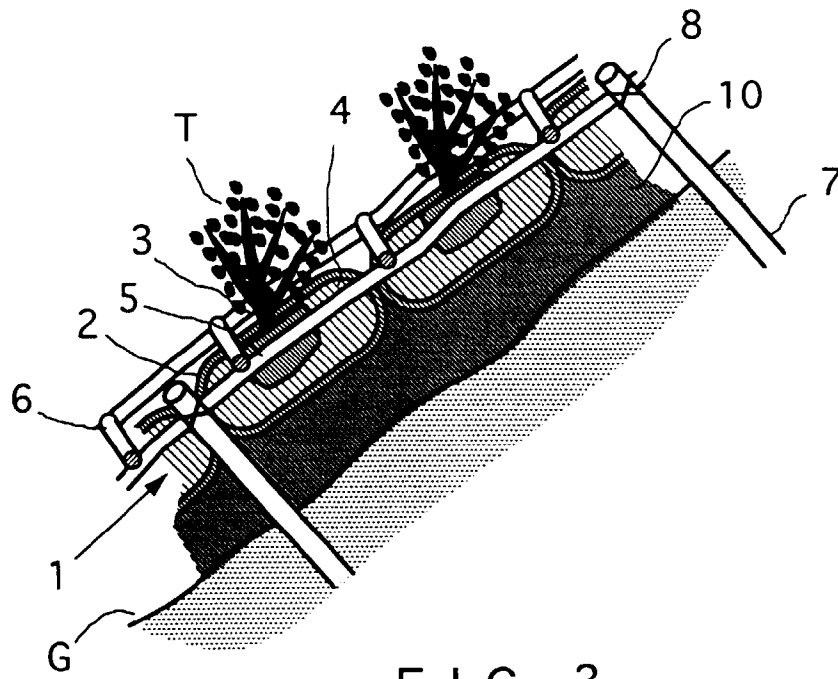

FIG. 3

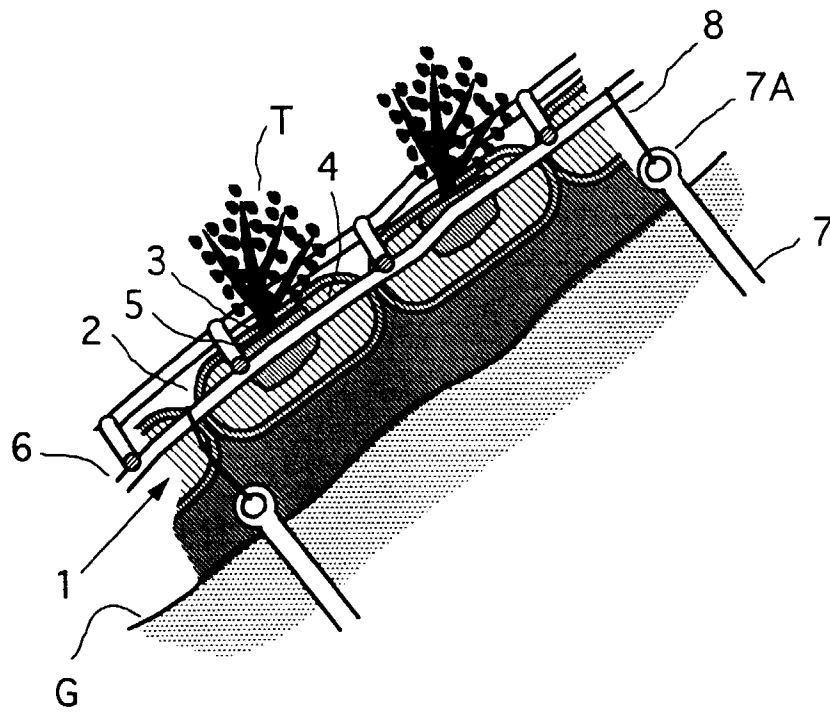

FIG. 4

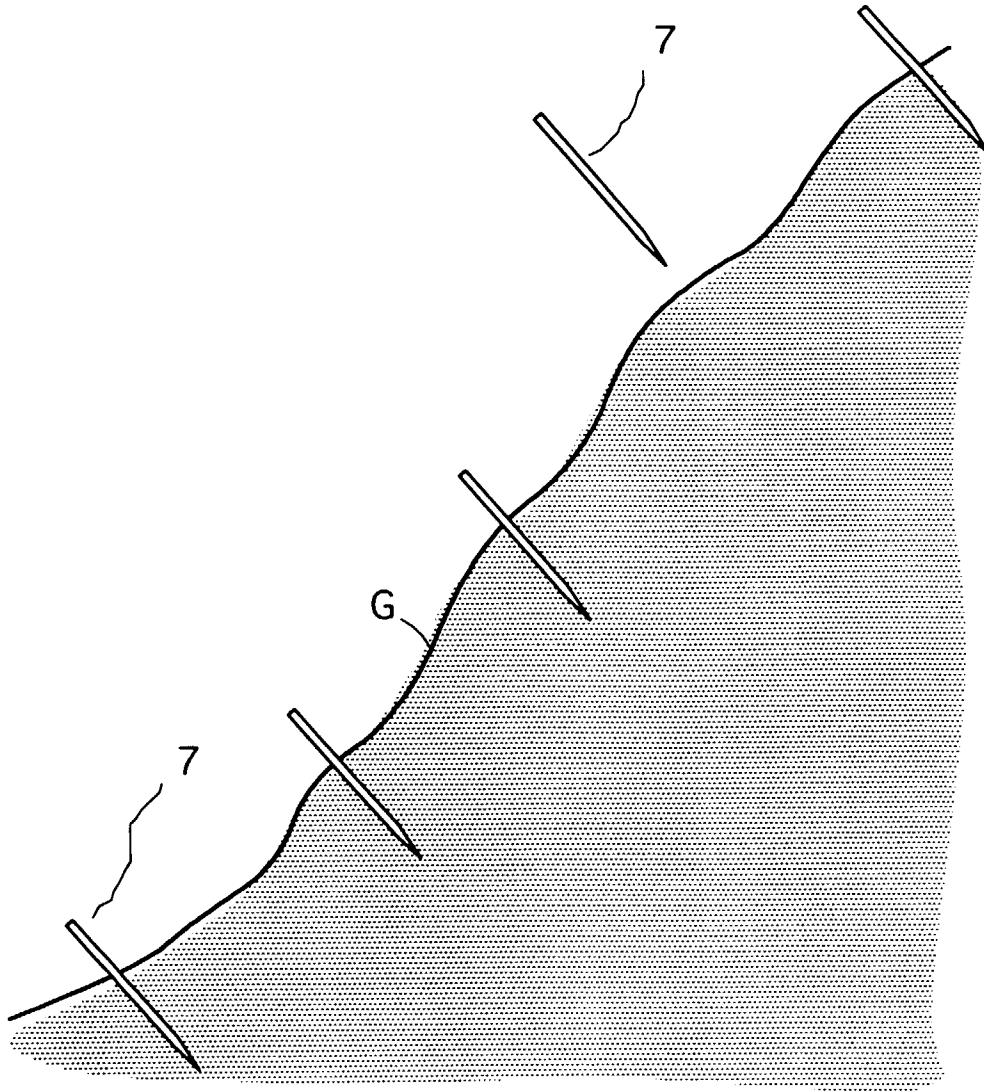

FIG. 5

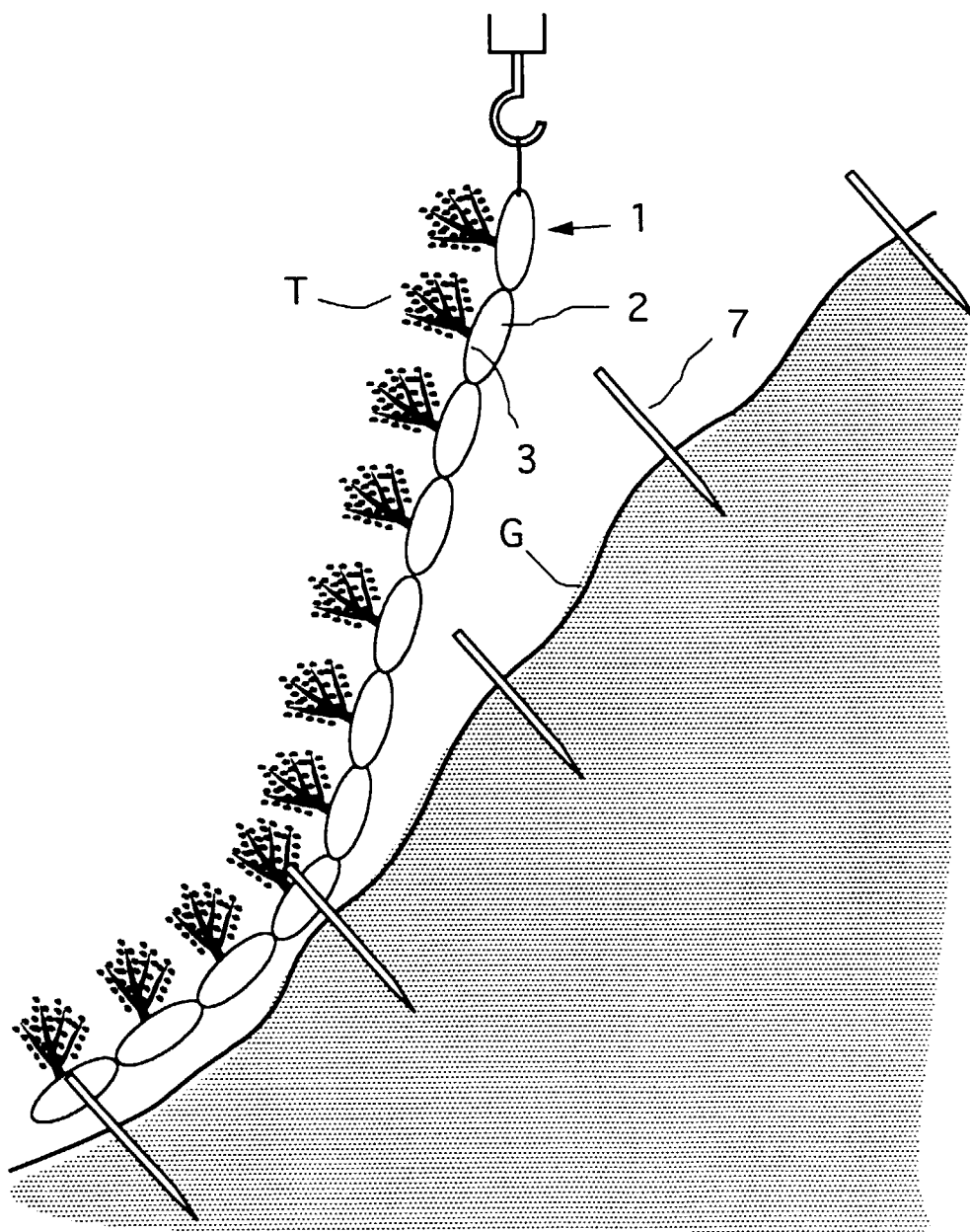

FIG. 6

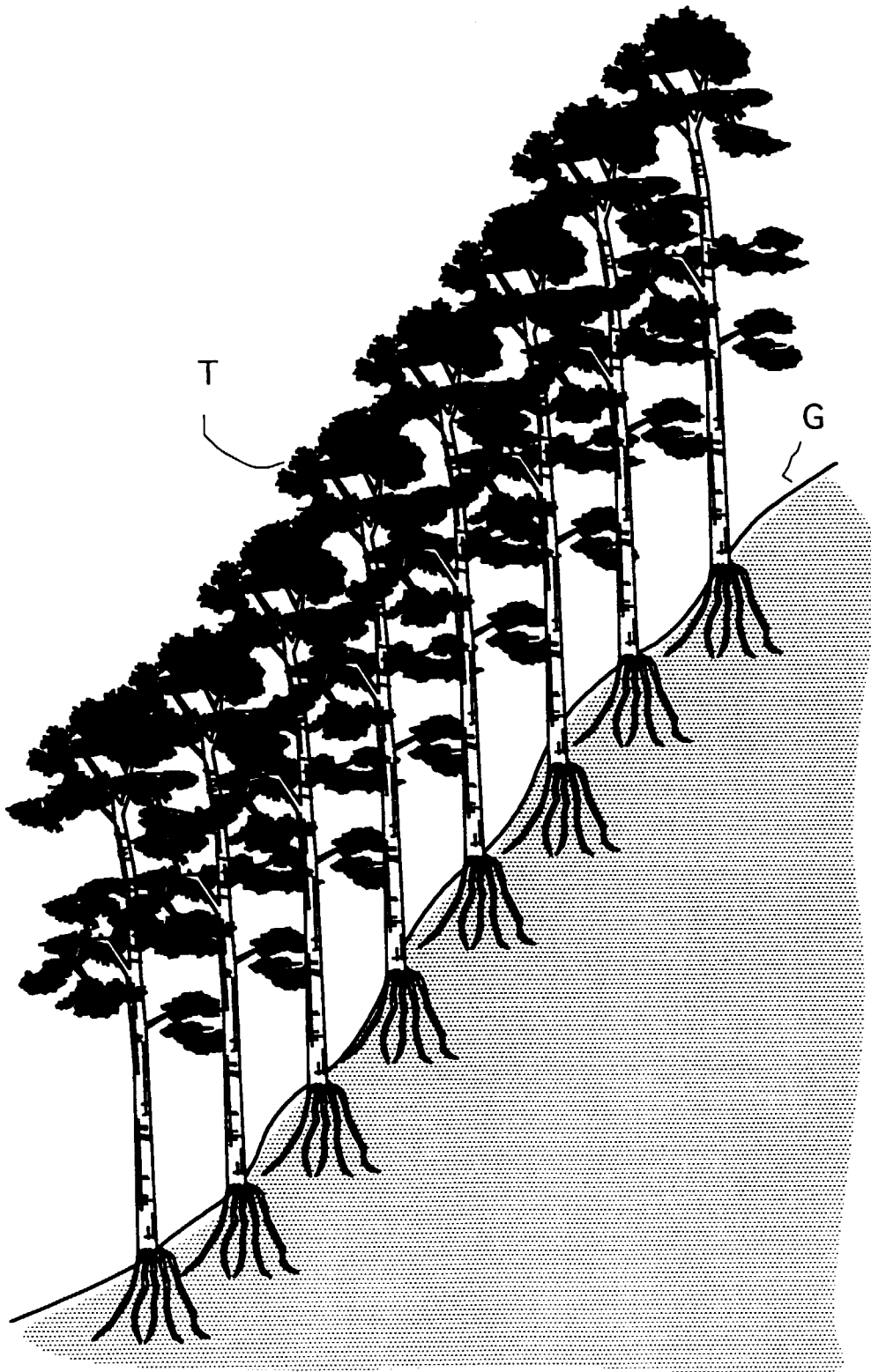

FIG. 7

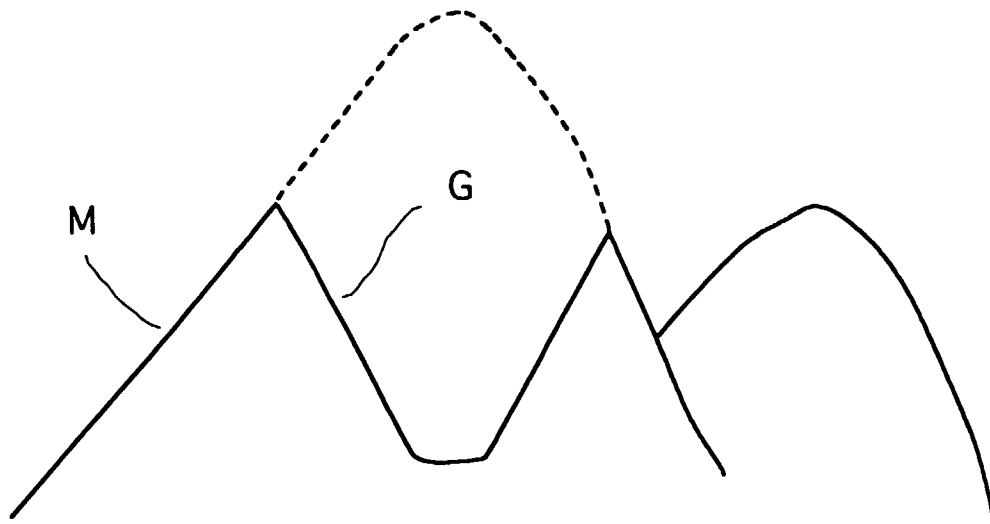

FIG. 8



European Patent  
Office

EUROPEAN SEARCH REPORT

Application Number  
EP 98 30 0243

DOCUMENTS CONSIDERED TO BE RELEVANT			
Category	Citation of document with indication, where appropriate, of relevant passages	Relevant to claim	CLASSIFICATION OF THE APPLICATION (Int.Cl.6)
A, D	GB 2 300 099 A (YUTAKA FUKUZUMI) * the whole document * ----	1	A01G1/00 A01G9/02
A	DE 23 21 362 A (NAUE) * the whole document * ----	1	
A	WO 96 20586 A (DAVIDSON) * page 3, paragraph 6 - page 7, paragraph 7; figures 1,2 * ----	1	
A	DE 21 34 306 A (WALDENFELS) * page 4, line 3 - page 6; figures 1-3 * ----	1	
A	DE 23 35 685 A (SCHIECHTL) * page 6, paragraph 5 - page 11, paragraph 1; figures 1-11 * -----	1	
			TECHNICAL FIELDS SEARCHED (Int.Cl.6)
			A01G A01C
The present search report has been drawn up for all claims			
Place of search		Date of completion of the search	Examiner
THE HAGUE		23 April 1998	Vermander, R
CATEGORY OF CITED DOCUMENTS			
X : particularly relevant if taken alone Y : particularly relevant if combined with another document of the same category A : technological background O : non-written disclosure P : intermediate document		T : theory or principle underlying the invention E : earlier patent document, but published on, or after the filing date D : document cited in the application L : document cited for other reasons & : member of the same patent family, corresponding document	

EPO FORM 1503 03 B2 (P04C01)