



(12) **EUROPEAN PATENT APPLICATION**

(43) Date of publication:
12.08.1998 Bulletin 1998/33

(51) Int Cl. 6: **E04B 1/68**

(21) Application number: **98300901.0**

(22) Date of filing: **06.02.1998**

(84) Designated Contracting States:
**AT BE CH DE DK ES FI FR GB GR IE IT LI LU MC
NL PT SE**
Designated Extension States:
AL LT LV MK RO SI

(72) Inventor: **Stern, Gerald William
Newcastle Upon Tyne, NE3 4JA (GB)**

(74) Representative: **Vinsome, Rex Martin
Urquhart-Dykes & Lord
St Nicholas Chambers
Amen Corner
Newcastle-Upon-Tyne NE1 1PE (GB)**

(30) Priority: **08.02.1997 GB 9702602**

(71) Applicant: **Alfas Industries Limited
Washington, Tyne & Wear NE 37 2SH (GB)**

(54) **Joint sealing device**

(57) A joint sealing device comprises two elongate components (20,26), each of generally uniform cross-section throughout its length. The first component (20) comprises, in cross-section, two parts (23,24) interconnected by a linear hinge (22) to enable the parts (23,24)

to fold towards each other. The mutually remote faces of those parts (23,24) are at least partially covered by a resilient material (25). The second component (26) is adapted for insertion between the parts (23,24) to urge them apart and is adapted to engage and be retained by locking means (28,29) on the first component (20).

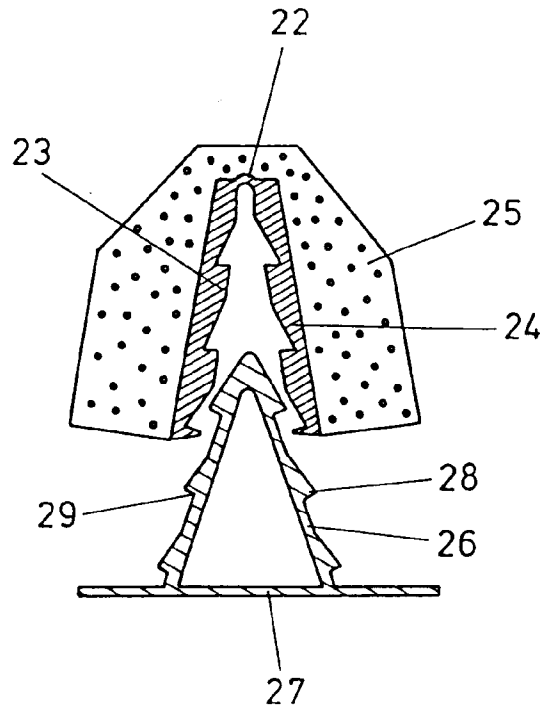

FIG. 2

Description

The present invention is concerned with joint sealing devices, such as are used to close and seal the generally linear gaps which are formed during the construction of walls, floors and ceilings as well as the installation of construction elements such as window frames and panels. Such gaps include expansion joints which are formed to accommodate expansion and contraction occurring between adjacent components. The gaps with which the invention is concerned may extend vertically, horizontally or at intermediate angles.

According to the present invention, there is provided a joint sealing device comprising two elongate components, each of generally uniform cross-section throughout its length, the first said component comprising, in cross-section, two parts interconnected by a linear hinge to enable them to fold towards each other, the mutually remote faces of those parts being at least partially covered by a resilient material, and the second said component being adapted for insertion between said parts to urge them apart and further being adapted to engage and be retained by locking means upon said first component.

In practice, the first component of the joint sealing device, of a size selected to reflect the gap size, is inserted in a folded condition into the gap and the second component is inserted progressively between the two parts of the first component until the desired seal is formed and the second component has been locked within the first component.

The two components of the joint sealing device according to the invention are preferably and most conveniently formed by extrusion. They may be made of a plastics material or of metal and may be made each of the same material or of different materials, for example the first component of plastics material and the second component of metal. Suitable materials include polyvinyl chloride, polyethylene, polypropylene, nylon, aluminium, brass, steel and combinations of these materials. The two parts of the first component are preferably, but not necessarily, mirror images in cross-section. The hinge is most preferably an integral hinge, formed during extrusion of the first component.

The second component of the joint sealing device is preferably of a tapered cross-section, for example generally triangular in cross-section, so that it may more effectively urge apart the two parts of the first component progressively as it is inserted between them. The second component may be of solid or hollow cross-section.

The locking means by which the two components are retained in interengagement most preferably takes the form of one or more linear projections or sockets on the surface of one component adapted to engage one or more corresponding linear sockets or projections on the facing surface of the other component. Preferably the projection(s) and socket(s) are so shaped as to

make subsequent withdrawal of the second component difficult or effectively impossible. Most preferably more than one projection or socket is provided on at least one of the components, and preferably upon both of them, so that the components may interengage progressively in a ratchet-type locking fashion.

The external or rear faces of the first component, that is the outer faces of its two parts when it is folded, are at least partially covered by a resilient material. Preferably the resilient material covers at least a major part of those faces and it is particularly advantageous if the resilient material also covers the hinge, so that the material may act to tend to unfold the component in use. The resilient material is preferably a foamed plastics material, among which materials may specifically be mentioned open-cell or closed-cell polyvinyl chloride, polyethylene, polypropylene, polyurethane and poly(ethylene vinyl acetate), according to the quality of the seal required.

Preferably the resilient material has, on its face remote from the joint sealing component, a high-friction surface or a layer of adhesive, to prevent or minimise any movement of the device relative to the joint surface.

When the joint sealing device has been installed, a front face of the second component will normally remain visible. It is therefore particularly desirable that that face be extended, laterally of its length, so as to project beyond the edges of the joint. In this way, not only may the joint be very effectively sealed against the incursion of extraneous materials but also the appearance of the joint may thereby be enhanced. To that latter end, the front face of the second component may be given a decorative finish, which may if desired match or complement the surroundings of the joint.

As one alternative, the outermost edges of the first component of the joint sealing device may be extended laterally as aforesaid and the respective front faces of the two components may cooperate to provide a finish for the joint.

As already indicated, the two components may be formed in continuous lengths by extrusion. For practical reasons, they are preferably cut to manageable lengths, for example within the range from 2 to 4 metres, before installation. When the device is being installed, it is preferred that the two components be staggered lengthwise, such that the joints between adjacent lengths of the first component do not coincide with those of the second component.

The lateral dimensions of the two components are selected to reflect the dimensions of the joint. Typically gaps within the range from 5 to 100 mm and larger may be sealed by the device according to the present invention.

The invention will now be further described, by way of example only, with reference to the accompanying drawings, which illustrate, in cross-sectional view, various preferred embodiments of the joint sealing device and wherein:-

Fig. 1 shows the first component of one embodiment of the joint sealing device;
 Fig. 2 shows both components of the device of Fig. 1, prior to their interengagement;
 Fig. 3 shows the device of Figs. 1 and 2, installed in the position of use; and
 Figs. 4 to 10 show various further embodiments of the device according to the invention, all illustrated in the position of use.

Referring firstly to Figs. 1 to 3, the illustrated first component 20 comprises a continuous extruded length 21 of the selected plastics material, formed with a continuous lengthwise hinge 22 to enable it to fold in two parts 23, 24. The component has, bonded to the rear face of the material 21, a resilient foam 25, which extends across the parts 23, 24 and over the hinge 22. The foam tends to urge the component towards an unfolded condition. The second component 26 is extruded to form a hollow triangular section with an integral flat front face 27.

As illustrated, the inner face of the first component 20 when folded and the cooperating inclined faces of the second component 26 are provided with linear serrations 28 and grooves 29 so that, when the serrations and grooves are fully engaged as shown in Fig. 3, the two components cannot readily be separated. In that position, the parts 23, 24 of the first component are urged apart and tend to compress the foam 25 against the walls 30, 31 of a gap within which the device is located. The foam further assists in sealing the gap, which is closed off by the front face 27 of the second component. The foam exerts a constant outward pressure to maintain the integrity of the seal during any movement of the walls of the joint.

Fig 4 illustrates a variant form of the device of Figs. 1 to 3 in which the angle at the apex of the second component 32 is smaller than that of the component 26 of Figs. 1 to 3. Because the inclined faces of the component 32 are therefore steeper, a greater area of contact and compression is established between the device and the walls of the joint gap. The front face 33 of the component 32 is curved to enhance its appearance and the protection afforded by it.

The two embodiments of the invention illustrated in Figs. 5 and 6 respectively are devised to provide a seal for a recessed joint. In each case, the front face, 34 or 35, of the second component is modified, either to seal the gap at its outermost point as shown in Fig. 5 or to fit securely within the gap in the manner illustrated in Fig. 6.

Fig. 7 illustrates a form of the joint sealing device of the present invention which is specifically adapted for fitting to seal a gap between joint walls 36 and 37 meeting to form a corner. In that device, one edge 38 of the front face 39 of the second component 40 has been formed in a flexible material co-extruded with the component 40 and functions as a sealing gasket against the wall 37.

In the device illustrated in Fig. 8, the outer edges of the first component 41 are extended laterally in the form of lips 42, 43, which engage the wall 44 at each side of the gap in which the device is located and retain the component 41 in position. The front face 45 of the second component 46 is designed to fit flush with the front of the retaining lips.

Figs. 9 and 10 show two forms of the invention devised to seal smaller joint gaps. The second component in each case is extruded as a solid section, rather than hollow as in the other embodiments of the invention. In the case of Fig. 9, the components 47 and 48 are provided on each side with just two serrations 49 and mating grooves. The first face 50 of the second component 48 forms the cover for the gap.

In the case of Fig. 10, the components 51 and 52 are locked together by a single serration 53 and groove on each side. The edges of the first component 51 are extruded laterally to cover the gap and the front faces of the two components are flush.

The joint sealing devices according to the invention, in particular in the form of the illustrated embodiments, afford an effective way of sealing joints in a wide variety of situations. The devices are easily installed and are held in place by their own pressure and can accommodate a degree of movement within the joint when in use.

It will be appreciated by persons skilled in the art that the above embodiments have been described by way of example only and not in any limitative sense, and that various alterations and modifications are possible without departure from the scope of the invention as defined by the appended claims.

35 Claims

1. A joint sealing device comprising two elongate components, each of generally uniform cross-section throughout its length, the first said component comprising, in cross-section, two parts interconnected by a linear hinge to enable them to fold towards each other, the mutually remote faces of those parts being at least partially covered by a resilient material, and the second said component being adapted for insertion between said parts to urge them apart and further being adapted to engage and be retained by locking means upon said first component.
2. A device according to Claim 1, wherein the two components are formed by extrusion .
3. A device according to Claim 2, wherein the hinge is an integral hinge, formed during extrusion of the first component.
4. A device according to any one of the preceding claims, wherein said components are made of a plastics material and/or of metal.

5. A device according to any one of the preceding claims, wherein the two parts of the first component are mirror images in cross-section.
6. A device according to any one of the preceding claims, wherein the second component is of a tapered cross-section, for example generally triangular in cross-section. 5
7. A device according to any one of the preceding claims, wherein the locking means by which the two components are retained in interengagement takes the form of one or more linear projections or sockets on the surface of one component adapted to engage one or more corresponding linear sockets or projections on the facing surface of the other component. 10
15
8. A device according to claim 7, wherein the or each projection and socket are so shaped as to make subsequent withdrawal of the second component difficult or effectively impossible. 20
9. A device according to any one of the preceding claims, wherein the external or rear faces of the first component, that is the outer faces of its two parts when it is folded, are at least partially covered by a resilient material. 25
10. A device according to Claim 9, wherein the resilient material also covers the hinge. 30
11. A device according to Claim 9 or 10, wherein the resilient material has, on its face, remote from the joint sealing component, a high-friction surface or a layer of adhesive, to prevent or minimise any movement of the device relative to the joint surface. 35
12. A device according to any one of the preceding claims, wherein a front face of the second component in use is extended, laterally of its length, so as to project beyond the edges of a joint sealed by the device. 40

45

50

55

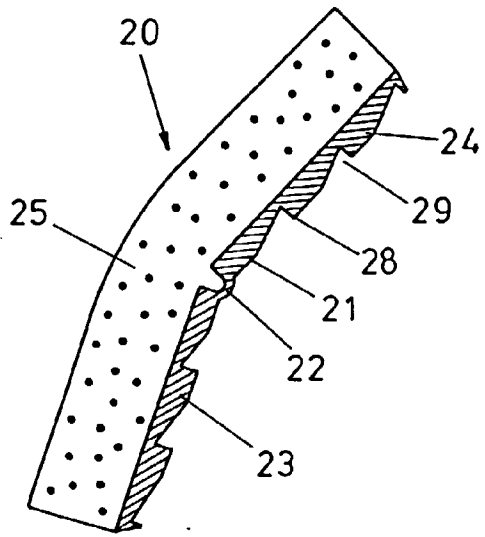

FIG. 1

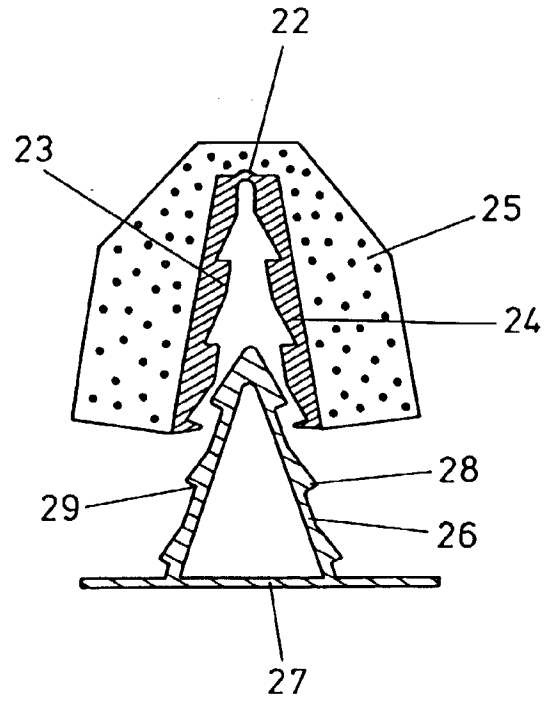

FIG. 2

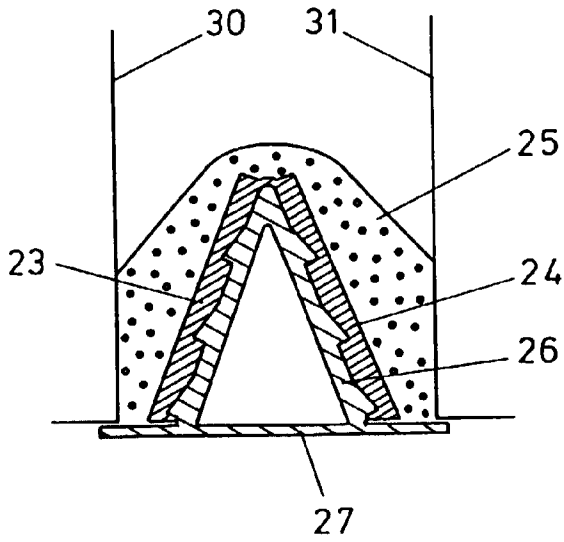

FIG. 3

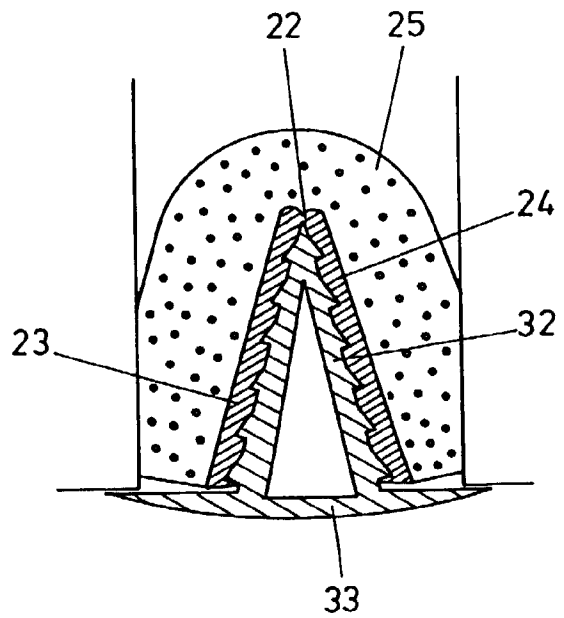

FIG. 4

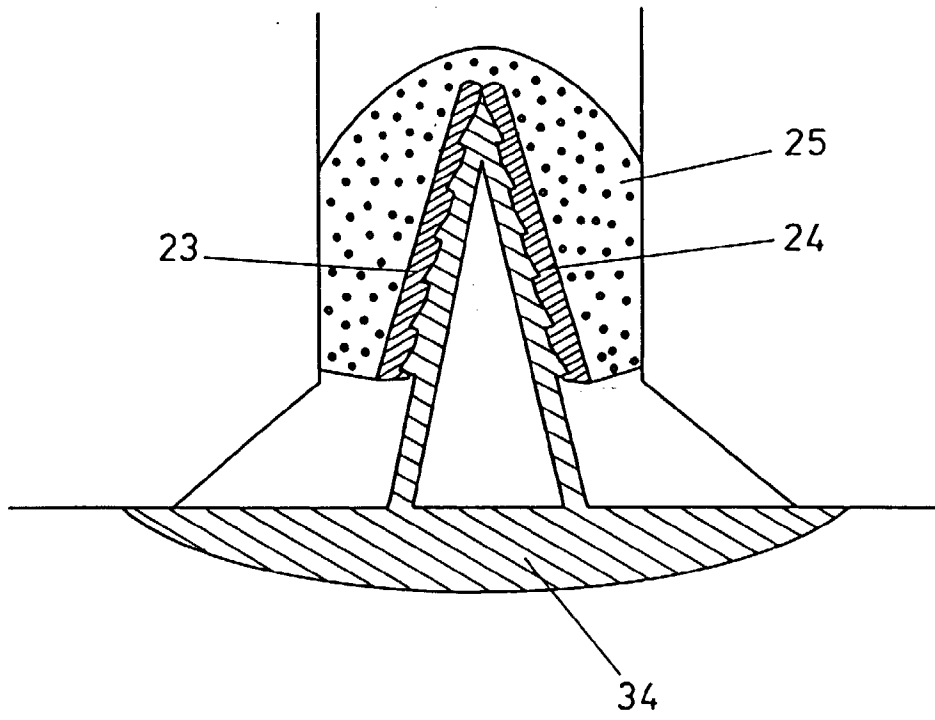

FIG. 5

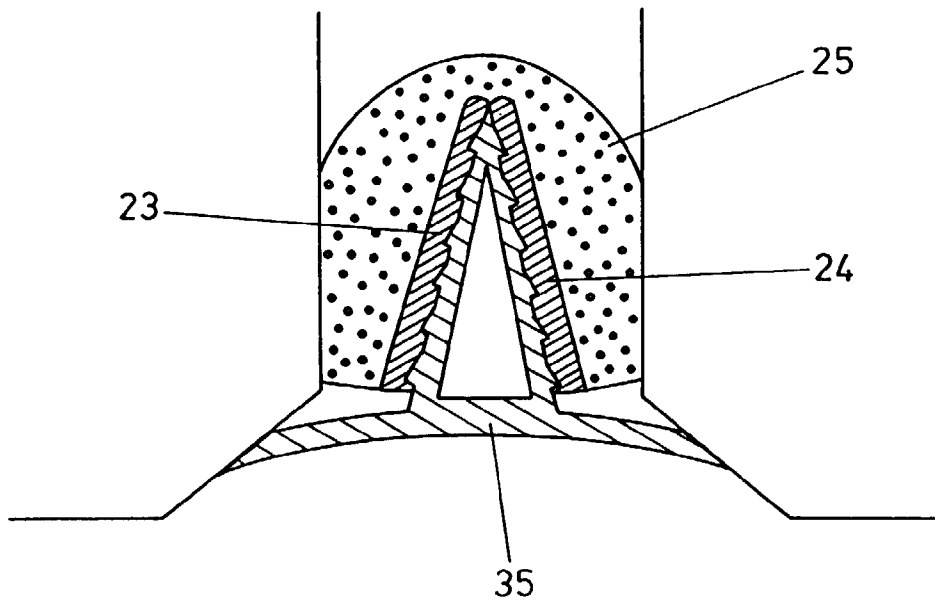

FIG. 6

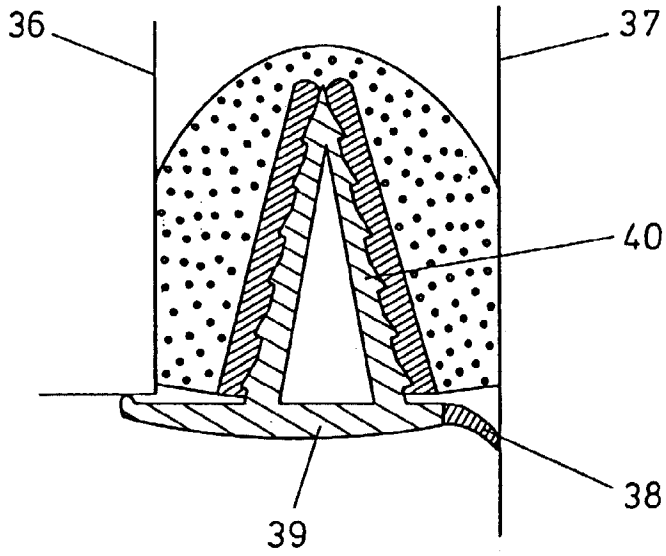

FIG. 7

FIG. 8

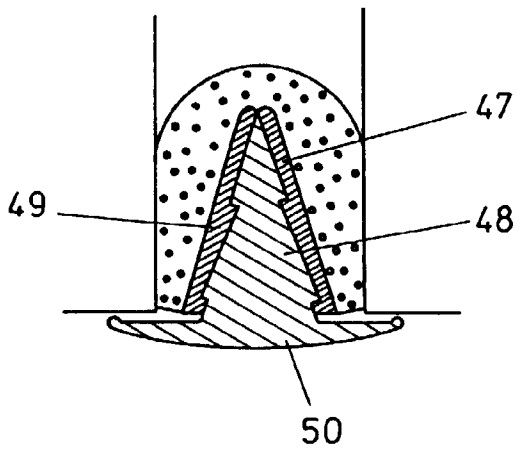
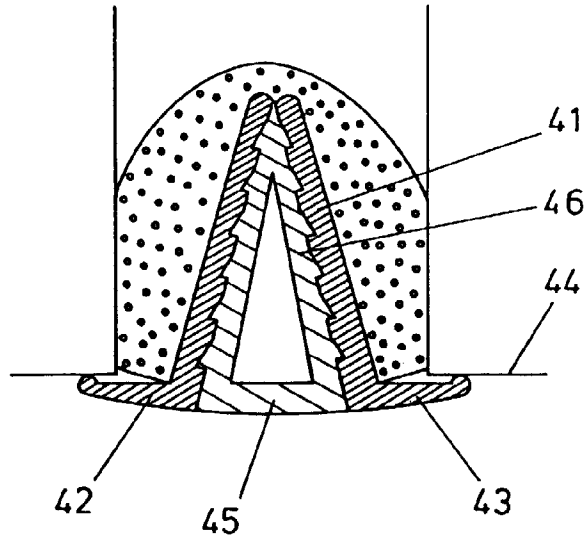

FIG. 9

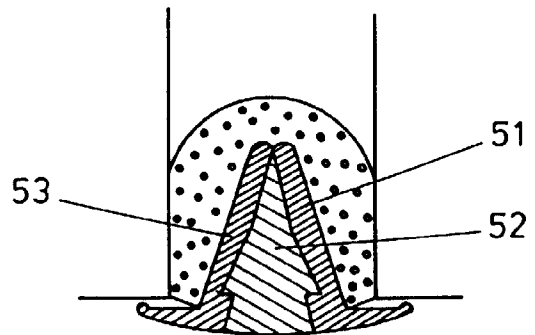

FIG. 10



European Patent Office

EUROPEAN SEARCH REPORT

Application Number
EP 98 30 0901

DOCUMENTS CONSIDERED TO BE RELEVANT			
Category	Citation of document with indication, where appropriate, of relevant passages	Relevant to claim	CLASSIFICATION OF THE APPLICATION (Int.Cl.6)
Y	FR 2 322 244 A (GREFCO) 25 March 1977 * page 7, line 18 - line 24 * * page 8, line 10 - page 9, line 16 * * page 10, line 7 - page 11, line 21; figures 1,2,4,6,8 * ---	1-5,7-9, 11,12	E04B1/68
Y	US 4 141 189 A (BORJESON JAN T) 27 February 1979 * column 6, line 26 - line 36; figures 6-10 *	1-5,7-9, 11,12	
A	DE 12 62 550 B (H. ENDER) * column 4, line 57 - line 68; figures 1-3 *	3,6	
A	DE 12 65 957 B (R. HEDICKE) * figure 1 *	6	
A	FR 1 252 603 A (R. MARANTIER) 8 May 1961 -----		
			TECHNICAL FIELDS SEARCHED (Int.Cl.6)
			E04B
The present search report has been drawn up for all claims			
Place of search THE HAGUE		Date of completion of the search 15 May 1998	Examiner Kriekoukis, S
CATEGORY OF CITED DOCUMENTS X : particularly relevant if taken alone Y : particularly relevant if combined with another document of the same category A : technological background O : non-written disclosure P : intermediate document T : theory or principle underlying the invention E : earlier patent document, but published on, or after the filing date D : document cited in the application L : document cited for other reasons & : member of the same patent family, corresponding document			

EPO FORM 1503 03/82 (P04/C01)