



Europäisches Patentamt
European Patent Office
Office européen des brevets



(11) EP 0 857 941 A1

(12) **EUROPEAN PATENT APPLICATION**
published in accordance with Art. 158(3) EPC

(43) Date of publication:
12.08.1998 Bulletin 1998/33

(51) Int. Cl.⁶: F42D 5/04, F42B 33/00

(21) Application number: 96928753.1

(86) International application number:
PCT/RU96/00221

(22) Date of filing: 07.08.1996

(87) International publication number:
WO 97/06403 (20.02.1997 Gazette 1997/09)

(84) Designated Contracting States:
AT BE CH DE DK ES FI FR GB GR IE IT LI LU MC
NL PT SE

- KLYAMKO, Andrei Stanislavovich
St.Petersburg, 191000 (RU)
- LAZAREV, Iury Mikhailovich
Moscow, 125183 (RU)
- LAZORKIN, Valery Ivanovich
St.Petersburg, 197022 (RU)
- LUKASHVILI, Vakhtang Archilovich
St.Petersburg, 196211 (RU)
- NOVIKOV, Valentin Ivanovich
St.Petersburg, 199034 (RU)

(30) Priority: 10.08.1995 RU 95114338

(71) Applicant:
Vnedrencheskaya Firma "Tsenter
Perspektivnykh Issledovany" (VF "CPI")
St. Petersburg, 191180 (RU)

(74) Representative:
Urizar Anasagasti, José Antonio et al
Puerto Rico 6A, Bajo
28016 Madrid (ES)

(72) Inventors:
• BASHMAKOV, Anatoly Konstantinovich
St.Petersburg, 199397 (RU)
• GEORGIADI, Valery Vazgenovich
St.Petersburg, 197349 (RU)

(54) **DEVICE FOR DESTROYING EXPLOSIVE OBJECTS**

(57) The claimed device is intended for use in destroying explosive objects, including objects placed in inaccessible places, without triggering a full-scale explosion and without any preliminary diagnostic investigation. A non-rupturing casing (1) open at two opposite ends accommodates the following elements arranged one after the other: a shattering device (2) in the form of a packet of high-strength rods; a propellant (3) in the form of an explosive charge; and a wave suppresser (5). When the propellant (3) is detonated, the energy of the explosion drives the rods of the shattering device (2) towards the explosive object (7) at a speed sufficient to destroy the principal elements of the object's explosive device without triggering a full-scale explosion.

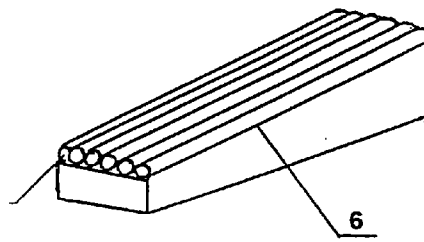

Fig. 2

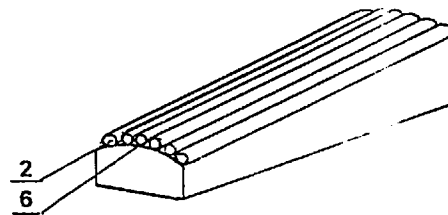

Fig. 3

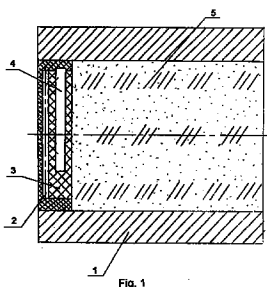

Fig. 1

EP 0 857 941 A1

Description

1. Field of Engineering

The invention refers to the range of anti-terrorist equipment, namely to render innocuous explosive objects without blasting an explosive, the objects being installed in locations with restricted access, under bottoms of vehicles, and in industrial complexes using hazardous technologies (chemical plants, nuclear power plants, etc.).

2. Prior Art Techniques

There exist known means for the destruction of explosive objects in place where they have been detected, or, when possible, after transportation to an appropriate location, which involves risks to the personnel and detrimental effect to the environment. Remote control devices for loading and moving objects reduce, to some extent, the risk level for personnel, but nevertheless the deterioration to the environment still persists.

A device has been invented for neutralizing an explosive object by means of freezing, made in a shape of a gun, which shoots a needle mounted on a plunger, the internal needle cavity being connected to a high pressure cell placed in connection with a source containing a neutralizing liquid (for example, liquid nitrogen). When the needle penetrates into the explosive object body, a neutralizing liquid starts to enter the case, and frozen object may be safely transported to the appropriate location for further annihilation. However, this device is claimed to be bulky and complicated, its explosion deteriorating the environment.

Detrimental effect to the environment can be avoided if an explosive object is destroyed without any blasting. There is a device made with a 12.7 mms. dummy charge shape, provided with a chisel like pig as a destroyer, which when hit breaks the components of the explosive object without blasting its charge. However, the destroyer shape makes it possible iyt's diversion during flight so becoming difficult to hit the charge properly in order to render the explosive object innocuous without blasting the charge.

The known hydrodynamic destroyer provides neutralization of an explosive object without blasting its charge with a higher chance of hitting the target. It refers to an explosive charge inserted into a metal cylinder case filled with water. The case is provided with an ejector opening. The explosive charge on blasting produces an excess pressure on the case, and a strong water stream flows through the ejected opening, and hitting precisely a specific part of an explosive object, destroying same object and thus neutralizing the object without blasting the charge contained in the object.

The drawbacks of these devices are generated by the need of reliable tests that require time and additional

means, as well as accurate target facilities. Particularly, it is almost impossible to neutralize explosive objects located in inaccessible locations for it is very difficult to trace the target accurately.

3. Description of the invention

The main objective of present invention is to create a device for the destruction of explosive objects, including those located in locations of difficult access, without blasting their charges, in a timely and reliable manner and with minimum possible risks for personnel.

The main feature of the device as the object of the invention is, its purpose being the destruction of explosive objects, that it contains an ejecting charge and a destroyer, with a housing made open at two opposite sides and which contains a sequential allocated destroyer (a pack of rods), an explosive charge as an ejector and a wave damper.

The destroyer rods are made of metal or other similar strong material including composites. The damper (i.e. sand) is enclosed in a shell that will easily get destroyed on blasting of the charge. The destruction rods are placed across the longitudinal axes of housing. When the ejector comes into action, the rods fly with axes perpendicular to path center line and on hitting the target object they physically chop the object and therefor destroy it. The speed of destruction rods is between 400 and 700 meters/second (mps) provided that ration of rods mass (m_1) and ejector explosive material (m_2) is $m_1/m_2 = 9 \div 3$. This value of destroyer speed does not initiate blasting of the explosive object.

The ejector is made in a wedge shape and skewed to destroyer side. This arrangement provides a rotation of the rods during flight perpendicularly to rods axes and makes it possible for the rods to disintegrate an explosive object rather than chop it what results in being much more efficient. This also makes it possible to reduce the amount of destruction rods and, consequently, the weight and size of the whole device. The skewed side of the wedge is cylinder convex shaped. If this is the case, destruction rods scatter in form of a fan blades, thus covering a large area, and therefor affecting a larger area of the object to be destroyed, which also makes it possible to reduce the size of mentioned device.

The inventor and the applicants are not aware of any destruction devices provided with a housing which contains ejector and destroyer open at both sides. Such devices would have been inefficient (inoperative). The efficiency of the device object of present application is high due to the use of an explosive material which has never been used before as an ejector in destruction devices. All known types of ejectors in destruction devices worked on the concept of a pressure increase within the housing, i.e. on account of powder combustion in a cartridge case. When the pressure reaches a certain level, the destroyer starts to move, in the direc-

tion of the object to be destroyed, through an ejection hole in the housing. In the present application an instant transfer of energy from the ejector to the destroyer occurs on blasting of the ejector charge, the destroyer flying out of the housing towards the object to be destroyed, the rest of energy being damped by means of the wave damper.

4. Brief Description of Figures.

Figure 1 shows a plan view of the device for destruction of explosive objects as the object of present application. Figure 2 shows a perspective view of the wedge shape ejector. Figure 3 shows a perspective view of the ejector with skewed side cylinder convex. Figure 4 shows the proportions of lotting areas depending upon the ejector shape.

The device for the destruction of explosive objects under present application (see Fig. 1) comprises a housing 1, open at both sides, one of which acts as an ejection opening, containing sequentially the destroyer 2, formed by a pack of rods made of metal or similar material of equal or greater strength, the ejector 3, made of an explosive material with a detonator 4, and a wave damper 5, which can, for example, be sand placed within a breakable cover and fillin the rest of interior of housing 1. The destroyer 2, the ejector 3 with the detonator 4 are fastened to the housing 1, for example enclosed inside a breakable polystyrol case.

The ejector 3 will actuate more efficiently if it has a wedge shape (see Fig. 2), with the pack of destruction rods 2 being placed on the skewwed side of said ejector. Higher efficiency will be obtained if the edge skewed side 6 of ejector 3 is made with cylinder shape (see Fig. 3).

5. Preferred Main Features of the Invention

The housing 1 internal diameter of the device for destruction of explosive objects, as the object of present application, is 80 mms, its length being 120 mms. The destroyer 2 contains from 5 to 10 metal rods which are 60 mms long and 1.5 to 2 mms in diameter. The ratio of mass of ejector 3 explosive charge to mass of rods pack is 3 to 9. The detonator wire 4 leads out of the housing.

The device for the destruction of explosive objects shall be placed close to the object, at a distance from 5 to 10 cms. The housing ejector opening 1 shall face the explosive object 7. The operator, sitting 5 to 10 meters away from vehicle where the explosive object was detected, will send an electrical signal to the detonator 4, thus blasting the ejector 3 explosive charge. The energy produced by ejector 3 blasting throws the destroyer 2 rods from the housing 1 towards the explosive object 7 which is to be destroyed. The speed of rods movement is between 400 and 700 mps. When hitting the explosive object, the rods chop up the object enclosure and all pieces contained inside said object:

wiring, power supply unit, timer or similar device for delaying the ignition of the explosive charge, and the explosive charge. Destruction of explosive object occurs without blasting the said explosive object. The remaining energy used to set off the ejector 3 charge is partially damped by the housing 1 and by the wave damper 5. The vehicle under which the explosive object 7 was placed will not suffer any damage.

If the speed of the destruction rods is lower than 400 mps, there will not be sufficient destructive effect as to completely destroy said explosive object 7. If the speed of destruction rods is over 700 mps, it might cause the blasting of said explosive object 7.

In order to achieve a more efficient destruction effect on components of explosive object 7, the ejector 3 explosive charge is made in a wedge shape, the pack of rods of destroyer 2 being placed on the skewed side 6 of wedge (see Fig. 2). When setting off the wedge shaped explosive charge 3, variable forces are applied to rods ends, thus creating a rotation torque. During the flight rods 2 rotate on a plane perpendicular to the rod axis and on hitting the explosive object, rods will chop up all pieces found in their path, thus reducing the amount of energy needed to destroy said explosive object. Furthermore, when hitting the explosive object pieces with different strength, rods 2 may change path direction, thus covering a larger area and increasing the destructive effects of said rods on explosive object 7. This feature makes it possible to reduce the amount of required energy of the ejector 3, as well as the amount of explosive material and the quantity of rods 2, therefore reducing the size of the device, as the object of present application, for the destruction of explosive objects.

The increase of the area, within the explosive object 7, affected by the destruction effect, for the same ejector 3 charge and quantity of rods 2 is obtained by means of making the skewed side 6 of ejector 3 wedge cylinder shaped (see Fig. 3). Rods 2 are evenly spread on wedge skewed side 6 of ejector 3. On setting off the explosive charge of ejector 3 a force is applied onto each rod, perpendicularly to the surface tangent line of said rod base. As a result of this, rods 2 will fly out of the housing 1 like fan blades, thus covering a larger area of explosive object 7.

Therefore, the device, as the object of present application, destroys the explosive object without preliminary diagnostics, thus reducing time waste, without blasting said explosive object since said explosive object is wholly disintegrated and, teherefore, eliminating possible risks for personnel and avoiding any damage to the vehicle under which said explosive object was placed. The small size of device and unnecessary accurate positioning (the precise positioning is required for all known devices) makes it possible to use the device, object of present invention, in the present application for the destruction of explosive objects places in any inaccessible location.

6. Industrial Use

The demand for a device for the destruction of explosive objects, as the object of present invention, has been generated by the current crime situation in many countries all over the world. 5

The destruction of explosive objects placed in inaccessible locations, in a wasteless and safe way, without the need for diagnosis or transportation, is of vital interest. These requirements are successfully met by the device, object of present invention, used to destroy explosive objects, as claimed in the present application. 10
Tests made showed a high degree of efficiency of the device object of present invention as well as the device readiness to be used in accordance with the features 15
claimed in the present application.

Claims

1. Device for the destruction of explosive objects, said device containing the ejector charge (3) and the destroyer (2) enclosed in an indestructible housing (1), with a case (1) featured in that it has openings on two opposite sides, with destroyer (2), pack of very strong rods, an explosive ejector charge (3) and a wave damper (5) like for ex. sand filling a breakable case, all located sequentially. 20 25
2. Device as claimed in Claim 1, featured in that the ejector (3) explosive charge is made with wedge shape and mounted on skewed face 6 facing the destroyer (2). 30
3. Device as claimed in Claims 1 and 2, featured in that the wedge skewed side (6) of ejector (3) has a cylinder shape. 35

40

45

50

55

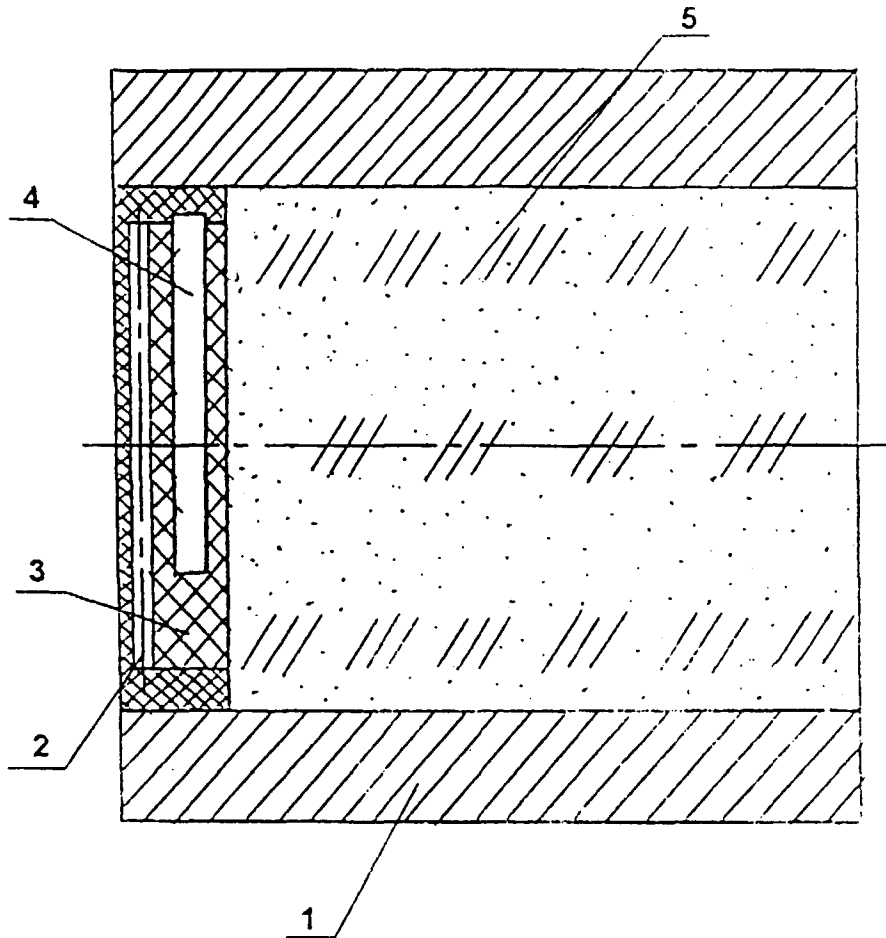

Fig. 1

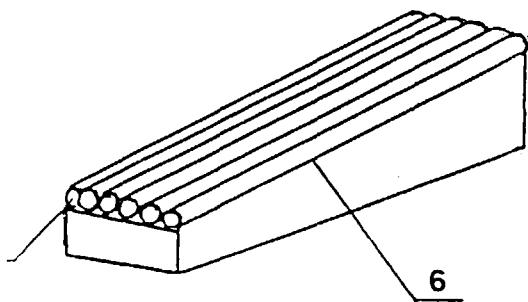

Fig. 2

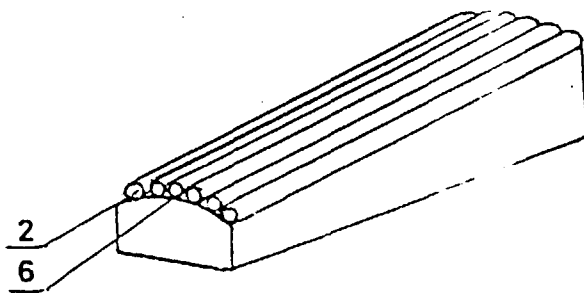

Fig. 3

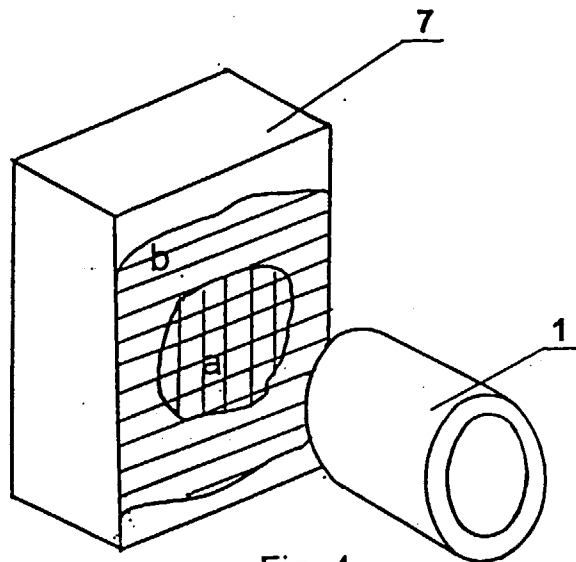

Fig. 4

INTERNATIONAL SEARCH REPORT

International application No.
PCT/RU/96/00221

A. CLASSIFICATION OF SUBJECT MATTER IPC⁶ : F42D 5/04, F42B 33/00 According to International Patent Classification (IPC) or to both national classification and IPC		
B. FIELDS SEARCHED Minimum documentation searched (classification system followed by classification symbols) IPC⁶ : F42B 33/00, 33/06, F42D 5/00, 5/04 Documentation searched other than minimum documentation to the extent that such documents are included in the fields searched Electronic data base consulted during the international search (name of data base and, where practicable, search terms used)		
C. DOCUMENTS CONSIDERED TO BE RELEVANT		
Category*	Citation of document, with indication, where appropriate, of the relevant passages	Relevant to claim No.
A	SU, A1, 1595165 (RUSAK V.N. et al.) 15 October 1994 (15.10.94)	1-3
A	"Zarubezhnoe voennoe obozrenie", 1993, No 9, "Voenizdat", (Moscow), N.Zhukov, "Sredstva poiska i obezvrezhivanya vzryvoopasnykh predmetov", pages 22-24	1-3
A	US, A, 3905272 (THE UNITED STATES OF AMERICA PRESENTED BY THE SECRETARY OF THE ARMY), 16 September 1975 (16.09.75)	1-3
A	DE, A1, 4117398 (DIEHL GmbH), 03 December 1992 (03.12.92)	1-3
A	FR, A1, 2694391 (ETAT FRANCAIS REPRESENTE PAR LE DELEGUE GENERAL POUR L'ARMEMENT) 04 February 1992 (04.02.92)	1-3
<input type="checkbox"/> Further documents are listed in the continuation of Box C.		<input type="checkbox"/> See patent family annex.
* Special categories of cited documents: "A" document defining the general state of the art which is not considered to be of particular relevance "E" earlier document but published on or after the international filing date "L" document which may throw doubts on priority claim(s) or which is cited to establish the publication date of another citation or other special reason (as specified) "O" document referring to an oral disclosure, use, exhibition or other means "P" document published prior to the international filing date but later than the priority date claimed		"T" later document published after the international filing date or priority date and not in conflict with the application but cited to understand the principle or theory underlying the invention "X" document of particular relevance; the claimed invention cannot be considered novel or cannot be considered to involve an inventive step when the document is taken alone "Y" document of particular relevance; the claimed invention cannot be considered to involve an inventive step when the document is combined with one or more other such documents, such combination being obvious to a person skilled in the art "&" document member of the same patent family
Date of the actual completion of the international search 15 November 1996 (25.11.96)	Date of mailing of the international search report 24 December 1996 (24.12.96)	
Name and mailing address of the ISA/ RU	Authorized officer	
Facsimile No.	Telephone No.	